

[HYDROMOTRIX EVOLUTION VISIO 45 kW@1229000->1539000]

01- Carénage

<b>REFERENCE</b>	<b>Pièces</b>	<b>N°</b>
F3AA41254	Antenne Visio 11.50 ->	1
430256	Barre accrochage HM 40/45 91.36->	2
F3AA41279	Barre tableau de bord HMCD45 Visio 11.50->	3
F3AA41130	Châssis CD/EVO45 10.27->	4
430854	Côté CD/EVO45 10.27->	5
430854	Côté CD/EVO45 10.27->	6
F3AA41173	Dessous HM CD/EVO 45 10.27->	7
F3AA41277	Façade HMCD45 Visio 11.50->	8

[HYDROMOTRIX EVOLUTION VISIO 45 kW@1229000->1539000]  
01- Carénage

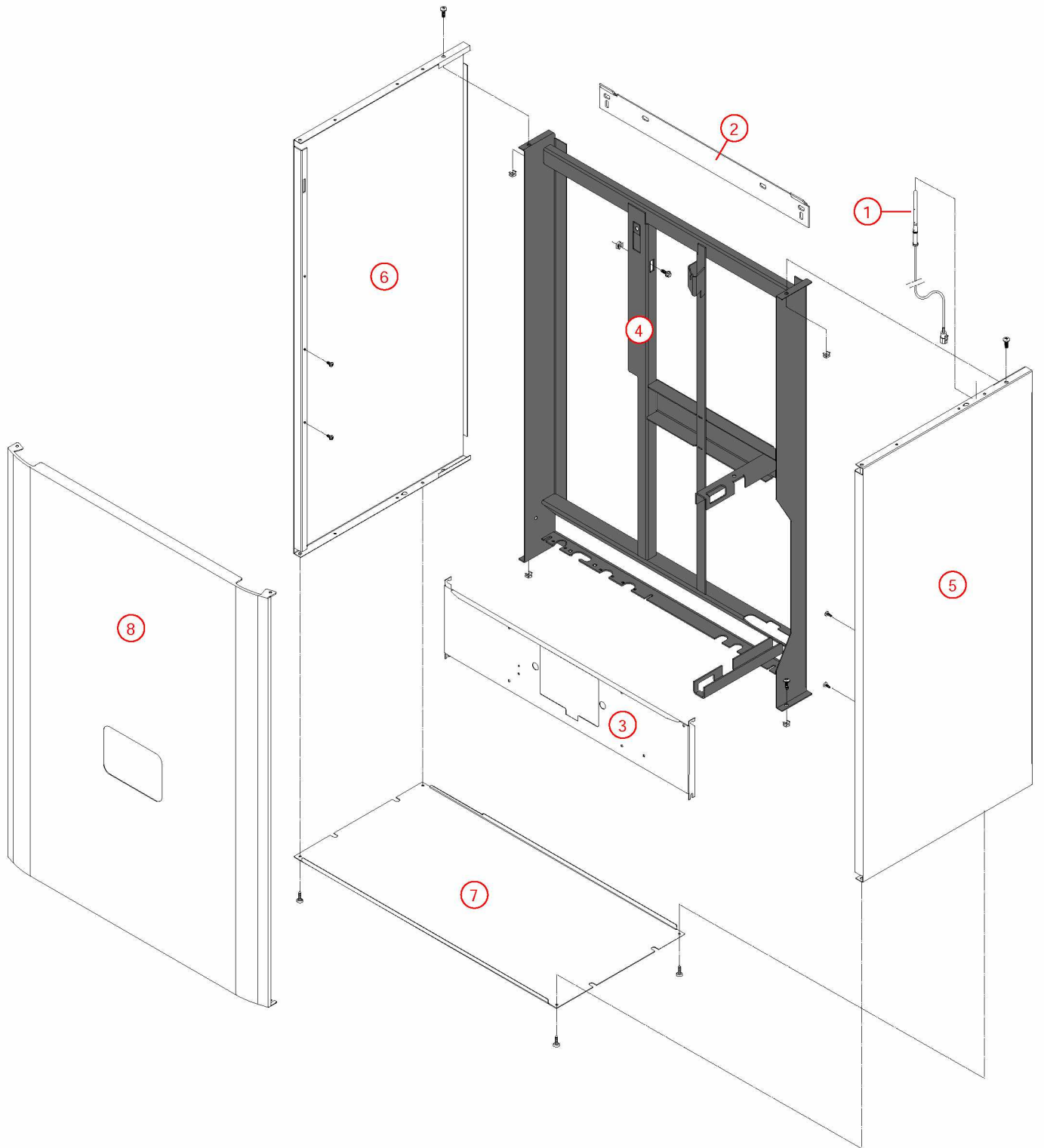

[HYDROMOTRIX EVOLUTION VISIO 45 kW@1229000->1539000]

02- Corps de chauffe

<b>REFERENCE</b>	<b>Pièces</b>	<b>N°</b>
435098	Accroch.sup.CDC V98 ->	1
450111	Calorifuge corps de chauffe EVO45 10.27->	2
400540	Chicane corps de chauffe CD/EVO lg 340 07.14->	3
435189	Collier serrage EVO45 10.27->	4
405391	Corps de chauffe + Calorifuge/joints EVO45 Mixte/C.S 10.27->	5
F3AA41126	Coupe tirage dia.180 EVO45 10.27->	6
F3AA40959	CTN à visser 1/4 fumée CD/EVO 25/32/45 07.14-> CD20 10.35->	7
F3AA40759	Joint de capteur de fumée HV32->08.05 EVO45 12.29->15.39	8
430853	Patte support transfo. allumage CD/EVO 45kW 10.27->	9
F3AA40790	Robinet de vidange 88.02->	10
410120	Vase rectangulaire 18 litres PREST.23/32kW	11

[HYDROMOTRIX EVOLUTION VISIO 45 kW@1229000->1539000]  
02- Corps de chauffe

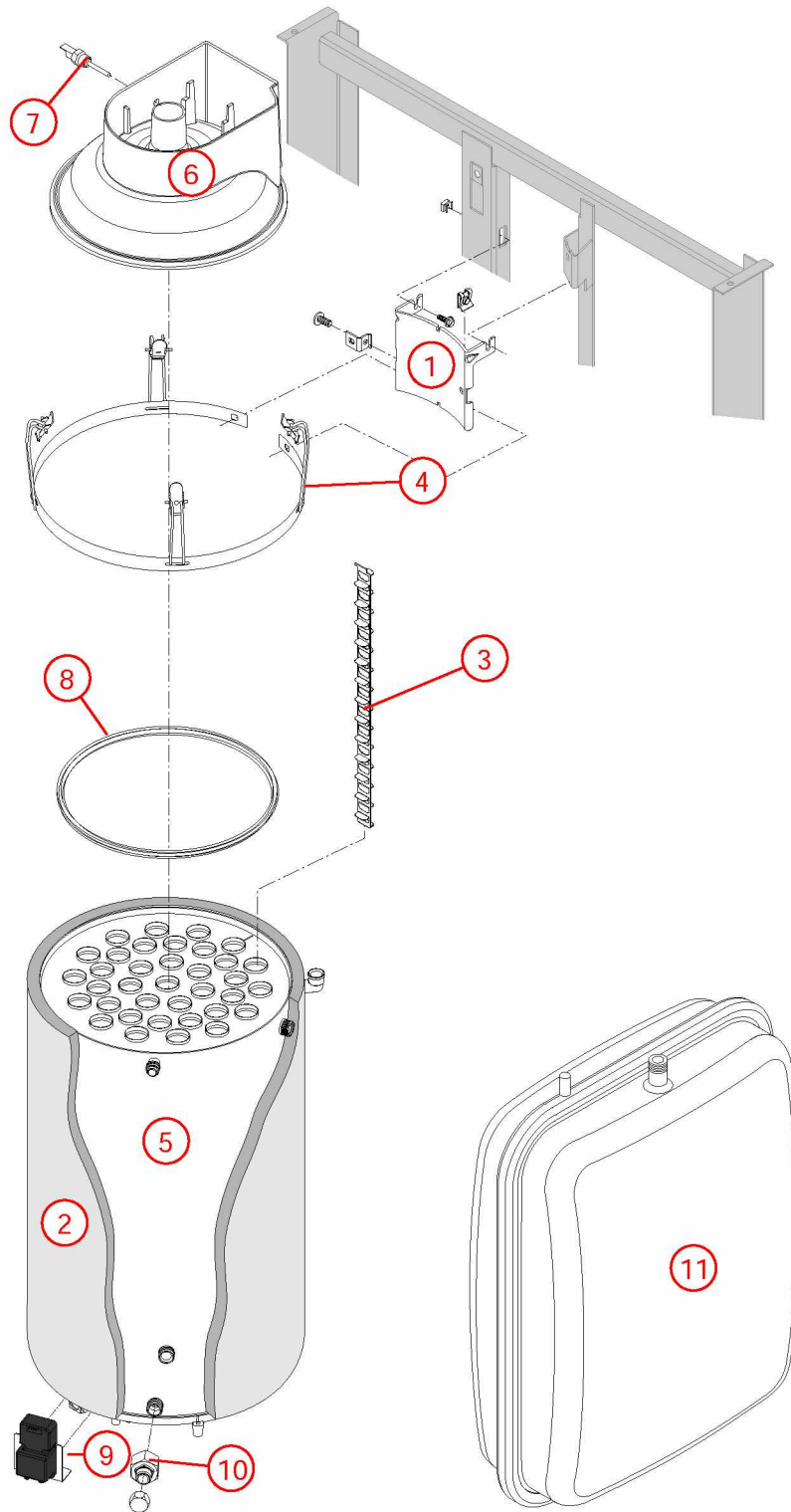

## [HYDROMOTRIX EVOLUTION VISIO 45 kW@1229000-&gt;1539000]

## 03- Circuit hydraulique

REFERENCE	Pièces	N°
F3AA40511	Capteur de pression 2000->	1
F3AA40437	Cartouche thermos. RTA 98->	2
F3AA40513	Circulateur 15/7-3 surpuissant 00.12->15.26	3
F3AA41433	Circulateur HR 15/7-5 surpuissant 15.27 ->	4
405391	Corps de chauffe + Calorifuge/joints EVO45 Mixte/C.S 10.27->	5
F3AA40515	CTN à clipper D:23.5 01.29->	6
F3AA40515	CTN à clipper D:23.5 01.29->	7
F3AA40520	Disconnecteur + 1 vanne arrêt 2000->	8
220515	Flexible TR.LG750 FF3/8 COU	9
F3AA40524	Moteur V4V 2000->	10
F3AA40540	Pochette de clips + vis 00.05->	11
F3AA40851	Pochette joint CD/EVO20/25/32 05.37->	12
F3AA40121	Purgeur automatique	13
F3AA40525	Purgeur manuel 2000->	14
F3AA40752	Raccord liaison recyclage 2000->	15
F3AA41155	Régulateur débit 16L bleu foncé	16
F3AA40532	RTA 2000->	17
F3AA40533	Soupape rac.3b 2000->	18
415489	Tube départ chauff.HMEVO45 10.27->	19
415488	Tube EC CD/EVO45 10.27->	20
415487	Tube EF CD/EVO45 10.27->	21
415244	Tube remplissage HM23 00.05->08.06 TRAD.23	22
415490	Tube retour chauff.HMEVO45 10.27->	23
F3AA40955	Tube soupape CD/EVO 25/32/45 07.14->	24
F3AA40736	Vanne 4 voies 03.16->	25
F3AA40536	Vanne isolement 1 MM + rempl. 2000->	26
F3AA40537	Vanne isolement 1 MM carré 2000->	27
410120	Vase rectangulaire 18 litres PREST.23/32kW	28

03- Circuit hydraulique

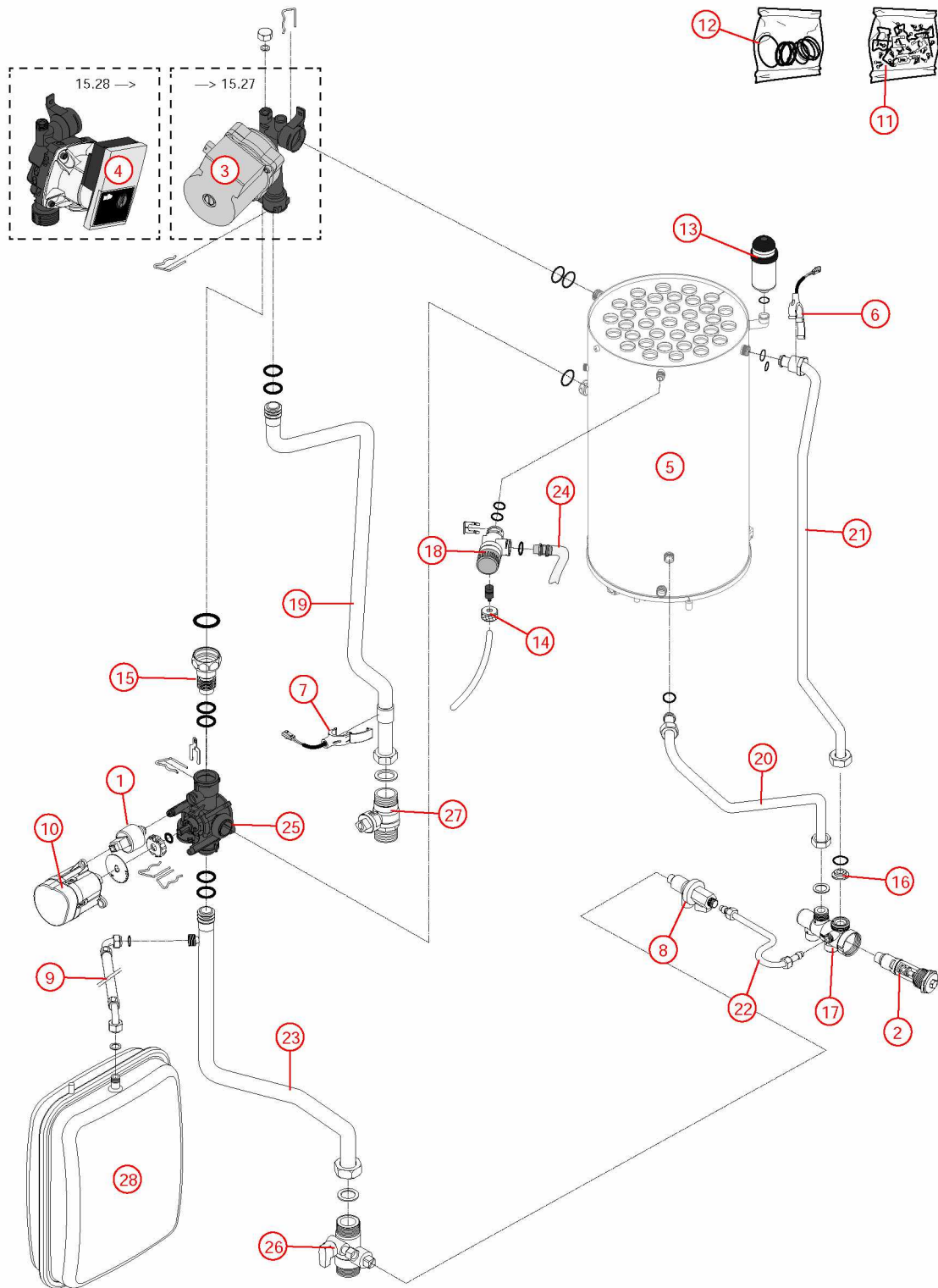

## [HYDROMOTRIX EVOLUTION VISIO 45 kW@1229000-&gt;1539000]

## 04- Circuit gaz

REFERENCE	Pièces	N°
F3AA41011	Bloc gaz DN EVO 08.07->	1
F3AA41012	Bobines EV bloc gaz EVO 08.07->	2
F3AA40936	Brûleur + jt CD/EVO32/45 07.20->	3
230167	Collier pour flexible air HV23 97.23->	4
F3AA41207	Condensateur motoventilateur 3MF/400 V	5
405391	Corps de chauffe + Calorifuge/joints EVO45 Mixte/C.S 10.27->	6
F3AA41138	Diaphragme gaz GN 645 EVO45 10.27->15.39	7
F3AA41136	Diaphragme gaz GR 740 EVO45 10.27->15.39	8
F3AA41137	Diaphragme gaz PRO 495 EVO45 10.27->15.39	9
F3AA41132	Electrode AL+ION CD/EVO45 10.27->	10
F3AA40950	Joint brûleur CD/EVO 25/32/45 07.14-> CD20 10.35->	11
F3AA41248	Lot joints électrode CD/EVO 05.37-> (5)	12
F3AA41070	Lot tubes pression manostat EVO	13
F3AA41128	Manostat EVO45 10.27->	14
F3AA41133	Motoventilateur EVO45 10.27->15.39	15
F3AA41127	Pales statiques CD/EVO45 10.27->	16
F3AA41390	Pochette joints gaz + vis bloc gaz TK25/ DN	17
F3AA41390	Pochette joints gaz + vis bloc gaz TK25/ DN	18
220487	Raccord TK25	19
440413	Robinet gaz 20x27	20
F3AA41104	Silencieux air EVO45 10.27->	21
440633	Support manostat HM EVO25/32 08.07->	22
425218	Tube gaz EVO45 10.27->	23
425202	Tube gaz HM/P25/32/45 EVO AVL 08.08->	24
F3AA40943	Turbine diam.12 CD20/25/32/45 EVO25/30/32/45 07.14->16.02	25
F3AA41480	Turbine diam.8 CD20/25/32/45 EVO25/30/32/45 16.03->	26

04- Circuit gaz

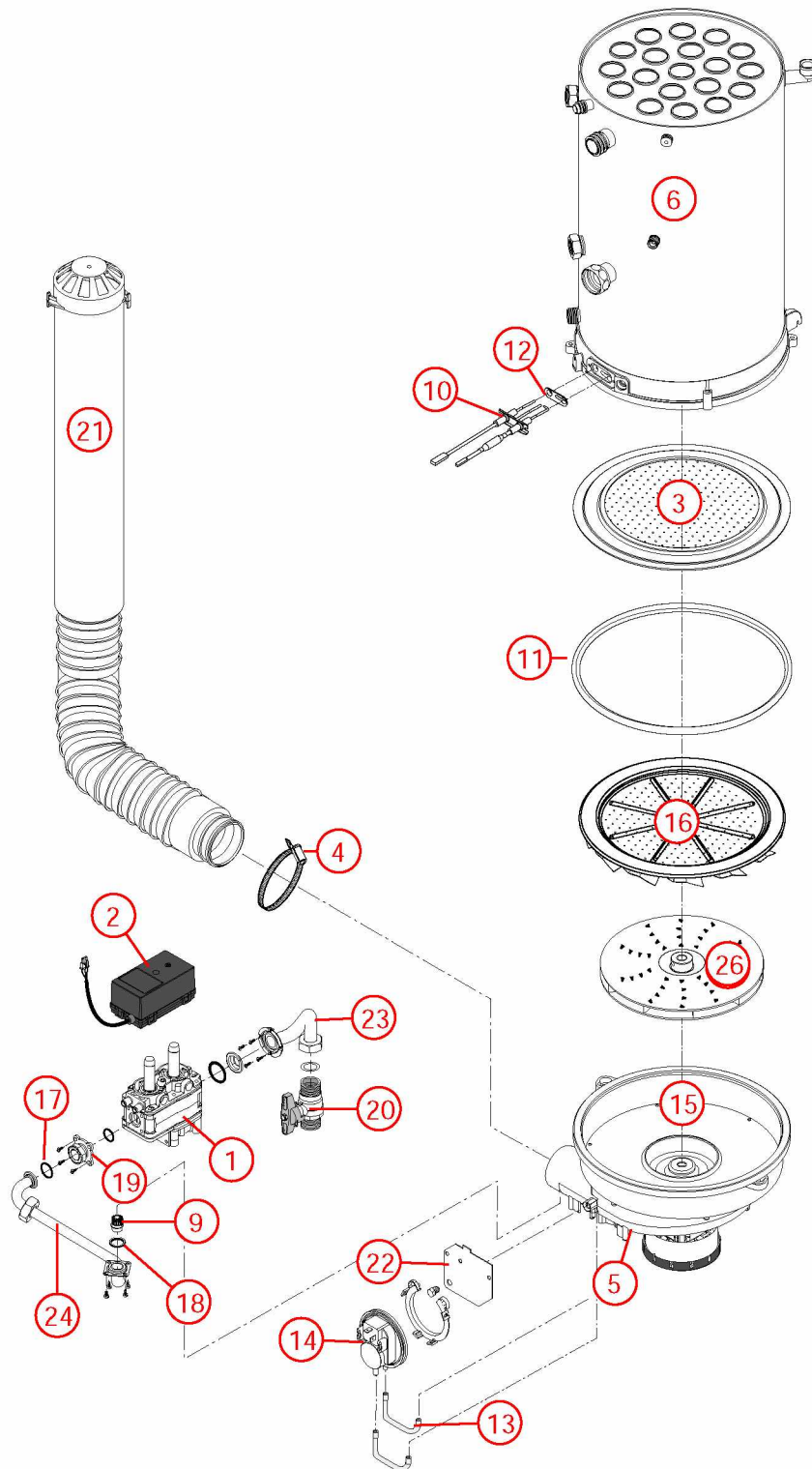



## [HYDROMOTRIX EVOLUTION VISIO 45 kW@1229000-&gt;1539000]

## 05- Câblage / commande

REFERENCE	Pièces	N°
F3AA41254	Antenne Visio 11.50 ->	1
F3AA41279	Barre tableau de bord HMCD45 Visio 11.50->	2
F3AA41011	Bloc gaz DN EVO 08.07->	3
F3AA41012	Bobines EV bloc gaz EVO 08.07->	4
F3AA40994	Boîtier électronique EVO25/30/32/45 08.07-> Travi23 1540->	5
F3AA41344	Câblage général HM45 EVO Visio 12.29->17.44	6
F3AA41344	Câblage général HM45 EVO Visio 12.29->17.44	7
250253	Câble adaptation transfo CD/EVO25/32/45	8
F3AA40511	Capteur de pression 2000->	9
F3AA40513	Circulateur 15/7-3 surpuissant 00.12->15.26	10
F3AA41433	Circulateur HR 15/7-5 surpuissant 15.27 ->	11
F3AA41207	Condensateur motoventilateur 3MF/400 V	12
F3AA41296	Cordon C.I /FAV Visio 11.50->	13
F3AA40515	CTN à clipper D:23.5 01.29->	14
F3AA40515	CTN à clipper D:23.5 01.29->	15
F3AA40959	CTN à visser 1/4 fumée CD/EVO 25/32/45 07.14-> CD20 10.35->	16
F3AA40516	CTN à visser 2000->	17
F3AA41132	Electrode AL+ION CD/EVO45 10.27->	18
F3AA41212	Lot fusible 3.15A 250V (5)	19
F3AA41213	Lot fusible 4A 250V (5)	20
F3AA41128	Manostat EVO45 10.27->	21
F3AA40524	Moteur V4V 2000->	22
F3AA41133	Motoventilateur EVO45 10.27->15.39	23
F3AA41221	Satellite Visio 11.50->	24
F3AA40157	Sécurité de surchauffe 220v 94°C 94.02->	25
F3AA41260	Support mural satellite Visio 11.50->	26
F3AA41253	Tableau de bord Visio 11.50 ->	27
F3AA40848	Transfo allumage CD20/25/32/45 05.37-> EVO25/32 08.08->	28

[HYDROMOTRIX EVOLUTION VISIO 45 kW@1229000->1539000]

05- Câblage / commande

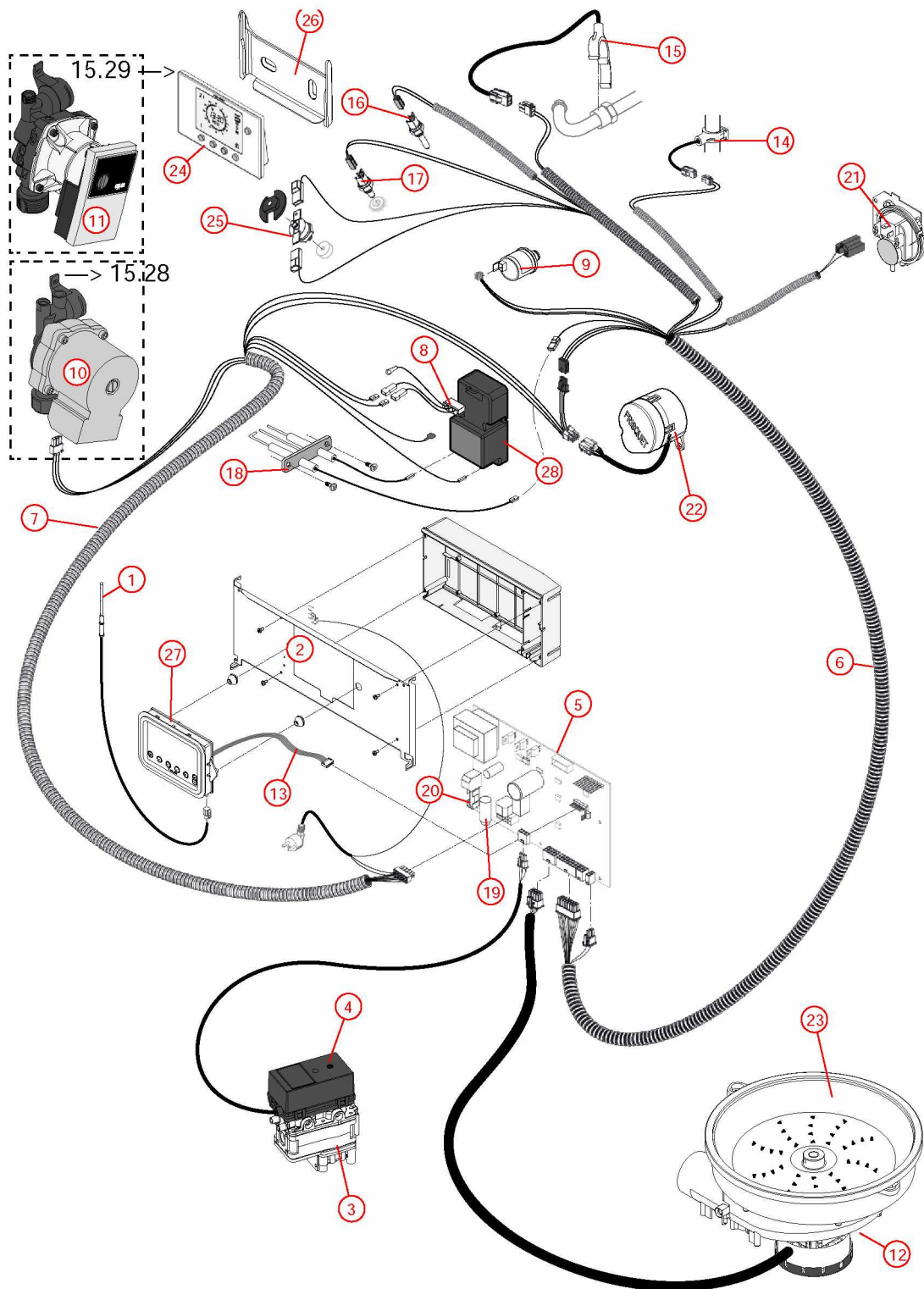

## [HYDROMOTRIX EVOLUTION VISIO 45 kW@1229000-&gt;1539000]

## 07-Module Hydraulique

<b>REFERENCE</b>	<b>Pièces</b>	<b>N°</b>
F3AA41251	Boîtier électronique Visio SAV 11.50->	1
F3AA41263	Bouchon capteur pression	2
F3AA41265	Câblage général Module Hyd.Visio 11.50->15.26	3
F3AA41447	Câblage général Module Hyd.Visio 15.27 ->	4
F3AA41262	Capot Module Hyd. Visio	5
F3AA41255	Capteur sonde extérieure Visio	6
F3AA41436	Circulateur HR 26x34-130	7
F3AA41264	Clapet antiretour DN20	8
F3AA40515	CTN à clipper D:23.5 01.29->	9
F3AA40524	Moteur V4V 2000->	10
250314	Prise coudée câble 1.55m	11
F3AA40752	Raccord liaison recyclage 2000->	12
220546	Raccord M3/4 tournant V4V	13
220546	Raccord M3/4 tournant V4V	14
225055	Raccord tournant F3/4-F1	15
220538	Té M/M/F	16
415535	Tube départ Module Hydraulique Visio	17
F3AA40736	Vanne 4 voies 03.16->	18
F3AA40144	Vanne isolement 3/4 carré	19
F3AA40144	Vanne isolement 3/4 carré	20

[HYDROMOTRIX EVOLUTION VISIO 45 kW@1229000->1539000]  
07-Module Hydraulique

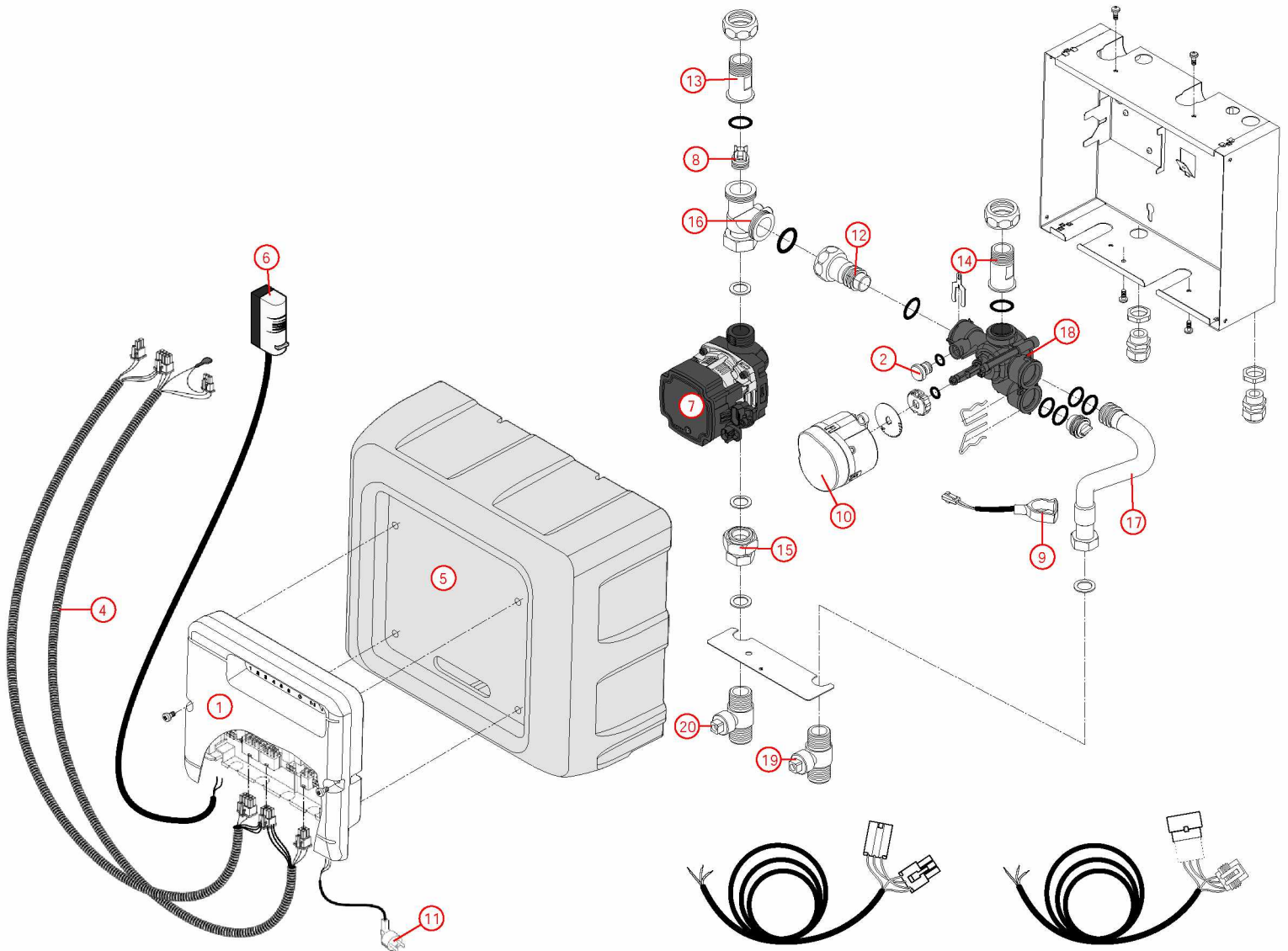

[HYDROMOTRIX EVOLUTION VISIO 45 kW@1229000->1539000]

031-2ème circuit hydraulique

<b>REFERENCE</b>	<b>Pièces</b>	<b>N°</b>
F3AA41442	Circulateur 33x42 HR 15.31 ->	1
F3AA40288	Circulateur 33x42 standard ->15.30	2
F3AA40836	Clapet antiretour 3/4MF	3
415437	Tube départ AMT HM EVO25/30/32 2ème circuit+circul 08.08->	4
415495	Tube départ chauff.EVO45 2E CIR AVL 10.27->	5
415567	Tube départ MH.HM45 EVO Visio 11.50->	6
415496	Tube retour chauff.EVO45 2ème circuit+circul 10.27->	7
415566	Tube retour MH.HM45 EVO Visio 11.50->	8
F3AA40144	Vanne isolement 3/4 carré	9
F3AA40144	Vanne isolement 3/4 carré	10

[HYDROMOTRIX EVOLUTION VISIO 45 kW@1229000->1539000]  
031-2ème circuit hydraulique

