

[HYDROMOTRIX EVOLUTION VISIO 32 kW@1229000->1539000]

01- Carénage

REFERENCE	Pièces	N°
F3AA41254	Antenne Visio 11.50 ->	1
430165	Barre accrochage GL/ HV32 HV23 00.06-> TGP 02.13->	2
430702	Barre de rigidité HMCD25/32 07.14->09.46 EVO 25/32 08.08->	3
F3AA41273	Barre tableau de bord HMCD25/32Visio 11.50->	4
230247	Bride support CDC CD/EVO25/32 07.14->	5
F3AA40941	Châssis CD/EVO 32 07.20->	6
430705	Côté CD/EVO 32 / UPEC 120 M	7
430705	Côté CD/EVO 32 / UPEC 120 M	8
F3AA41275	Façade HMCD32Visio 11.50->17.44	9

[HYDROMOTRIX EVOLUTION VISIO 32 kW@1229000->1539000]

01- Carénage

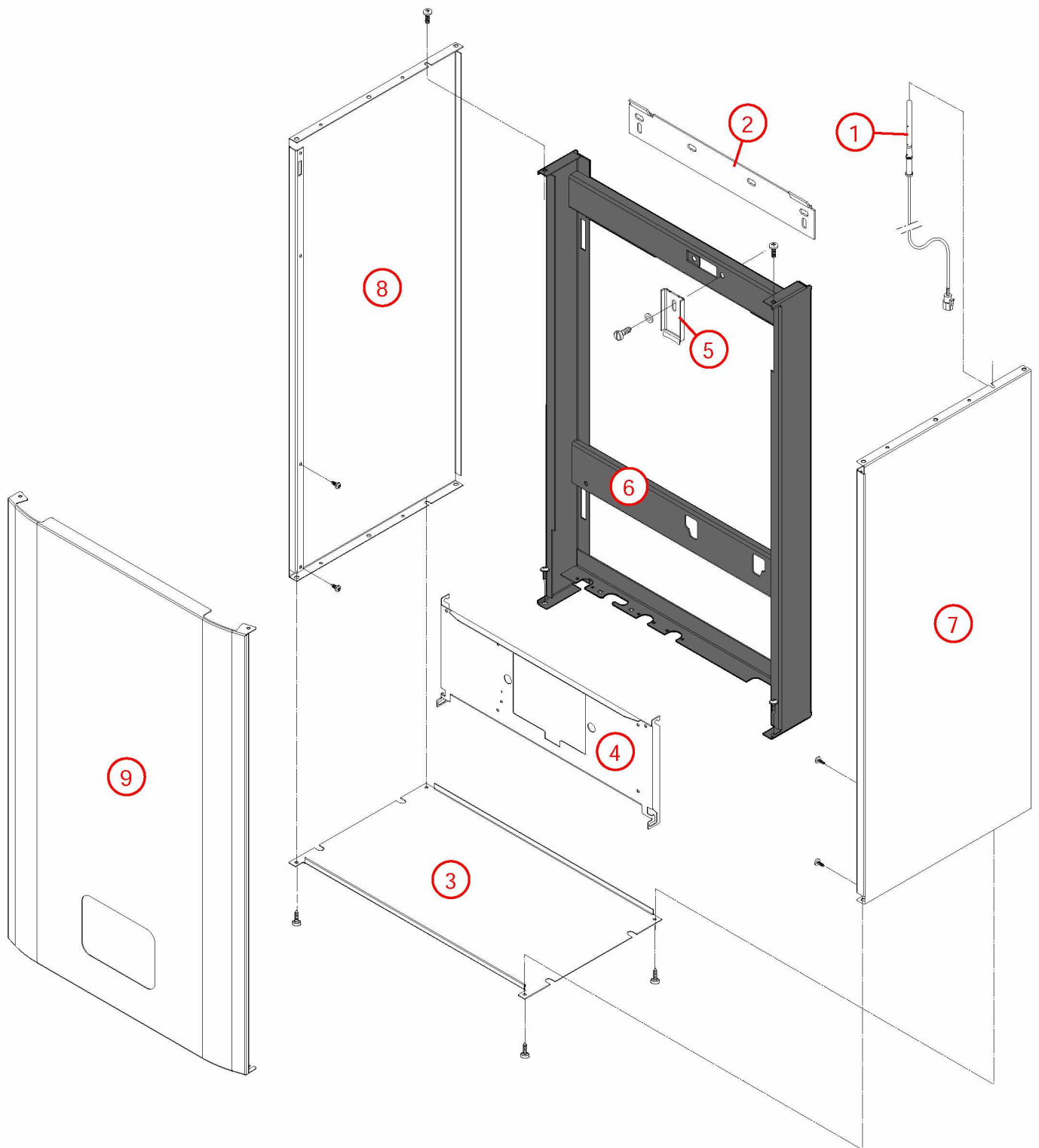

[HYDROMOTRIX EVOLUTION VISIO 32 kW@1229000->1539000]

02- Corps de chauffe / Vase

REFERENCE	Pièces	N°
220473	Bride fixation vase HM CD/EVO 32 07.20->	1
450098	Calorifuge corps de chauffe HM/P EVO32 08.09->	2
F3AA41010	Capteur fumée EVO 25/32 08.07->	3
400540	Chicane corps de chauffe CD/EVO lg 340 07.14->	4
F3AA41170	Chicanes (19) CD/EVO lg 340 07.14->	5
405386	Corps de chauffe + Calorifuge/joints HM/P32 EVO C.S/Mixte 08.09->	6
F3AA41019	Coupe tirage dia.139 EVO32 08.09->	7
F3AA40959	CTN à visser 1/4 fumée CD/EVO 25/32/45 07.14-> CD20 10.35->	8
F3AA40945	Joint couvercle fumée CD/EVO 25/32 07.14->	9
F3AA40948	Joint de capteur de fumées CD/EVO 25/32 07.14->	10
F3AA40938	Lot tirant capteur CD/EVO 32(X3) 07.20->	11
430703	Patte support transfo. allumage HMCD/EVO25/32 07.14->	12
F3AA40790	Robinet de vidange 88.02->	13
430707	Support vase inf. CD/EVO 32 07.20->	14
410181	Vase circulaire 12l CD/EVO 32	15

[HYDROMOTRIX EVOLUTION VISIO 32 kW@1229000->1539000]

02- Corps de chauffe / Vase

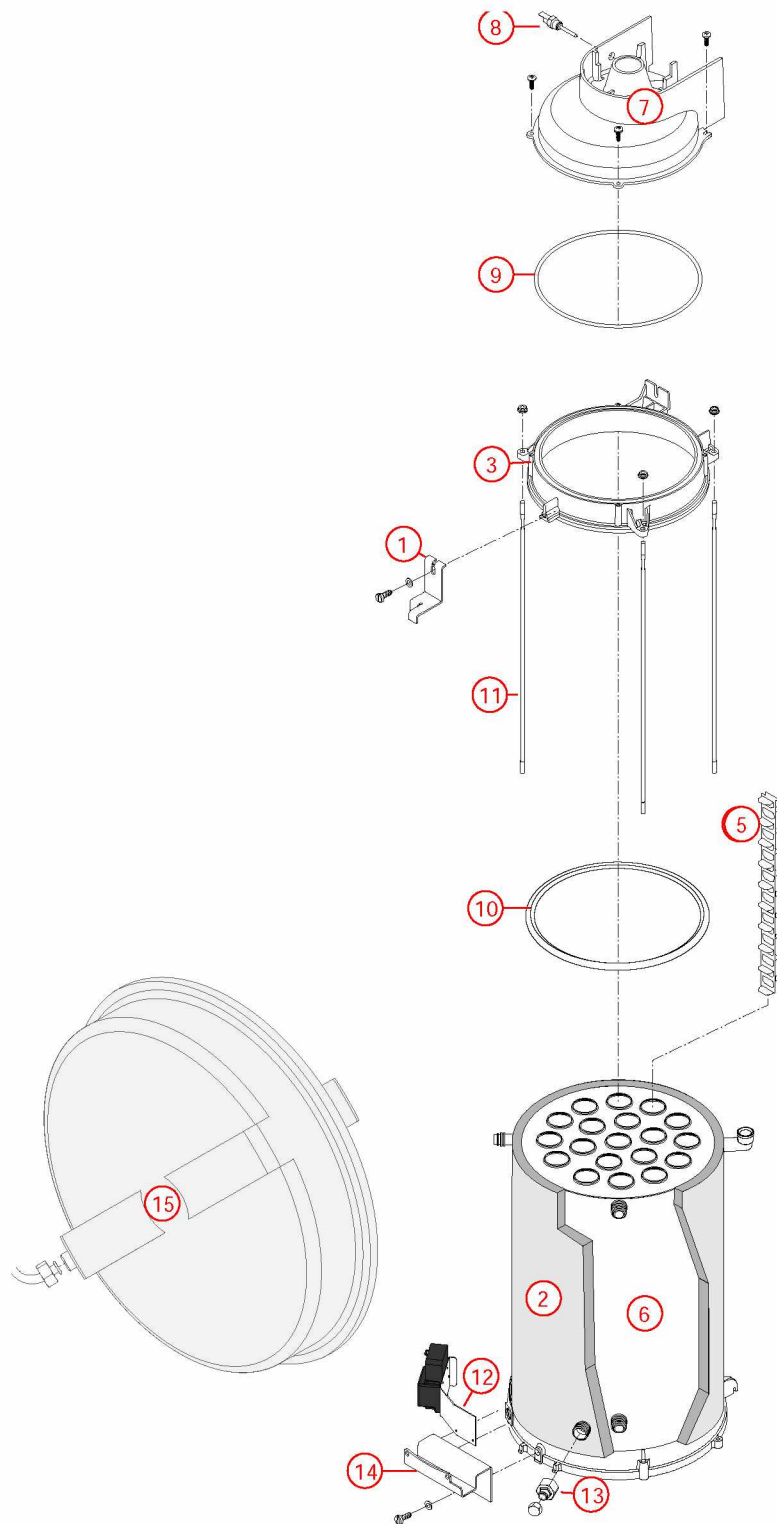

[HYDROMOTRIX EVOLUTION VISIO 32 kW@1229000->1539000]

03- Circuit hydraulique

REFERENCE	Pièces	N°
F3AA40511	Capteur de pression 2000->	1
F3AA40437	Cartouche thermos. RTA 98->	2
F3AA40512	Circulateur 15/5-3 standard 00.06->15.26	3
F3AA41431	Circulateur HR 15/6 standard 15.27->	4
405386	Corps de chauffe + Calorifuge/joints HM/P32 EVO C.S/Mixte 08.09->	5
F3AA40515	CTN à clipper D:23.5 01.29->	6
F3AA40515	CTN à clipper D:23.5 01.29->	7
F3AA40520	Disconnecteur + 1 vanne arrêt 2000->	8
F3AA40524	Moteur V4V 2000->	9
F3AA40540	Pochette de clips + vis 00.05->	10
F3AA40851	Pochette joint CD/EVO20/25/32 05.37->	11
F3AA40121	Purgeur automatique	12
F3AA40525	Purgeur manuel 2000->	13
F3AA40752	Raccord liaison recyclage 2000->	14
F3AA40241	Régulateur débit 12 litres (rouge)	15
F3AA40532	RTA 2000->	16
F3AA40533	Soupape rac.3b 2000->	17
415448	Tube départ chauff.HM32 EVO 08.09->	18
415393	Tube EC CD/EVO25/32 07.14->	19
415400	Tube EF CD/EVO 32 07.20->	20
415395	Tube rempl.CD/EVO25/32 07.14->	21
415449	Tube retour chauff. HM32 EVO 08.09->	22
F3AA40955	Tube soupape CD/EVO 25/32/45 07.14->	23
415450	Tube vase HM25/32 EVO 08.09->	24
F3AA40736	Vanne 4 voies 03.16->	25
F3AA40144	Vanne isolement 3/4 carré	26
F3AA40538	Vanne isolement 3/4 MM + rempl. 2000->	27
410181	Vase circulaire 12l CD/EVO 32	28

[HYDROMOTRIX EVOLUTION VISIO 32 kW@1229000->1539000]

03- Circuit hydraulique

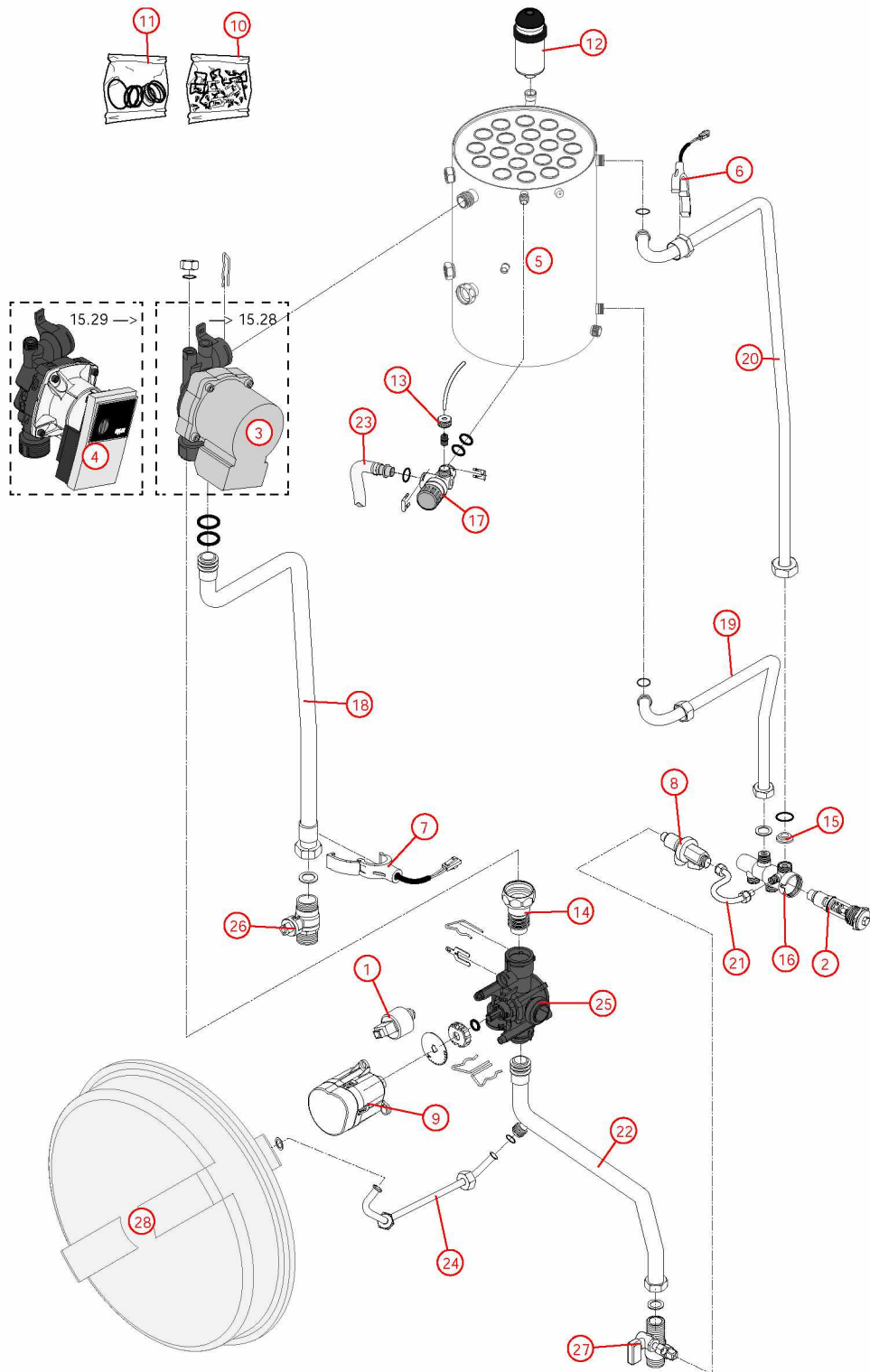

[HYDROMOTRIX EVOLUTION VISIO 32 kW@1229000->1539000]

04- Circuit gaz

REFERENCE	Pièces	N°
F3AA41011	Bloc gaz DN EVO 08.07->	1
F3AA41012	Bobines EV bloc gaz EVO 08.07->	2
F3AA40936	Brûleur + jt CD/EVO32/45 07.20->	3
230167	Collier pour flexible air HV23 97.23->	4
F3AA41207	Condensateur motoventilateur 3MF/400 V	5
405386	Corps de chauffe + Calorifuge/joints HM/P32 EVO C.S/Mixte 08.09->	6
F3AA41023	Diaphragme gaz GN 530 EVO32 08.09->15.39	7
F3AA41024	Diaphragme gaz GR 600 EVO32 08.09->15.39	8
F3AA41022	Diaphragme gaz PRO 410 EVO32 08.09->	9
F3AA40944	Electrode AL+ION CD/EVO 25/32 07.14->	10
F3AA40950	Joint brûleur CD/EVO 25/32/45 07.14-> CD20 10.35->	11
F3AA41248	Lot joints électrode CD/EVO 05.37-> (5)	12
F3AA41070	Lot tubes pression manostat EVO	13
F3AA41021	Manostat EVO32 08.09->	14
F3AA41020	Motoventilateur EVO32 08.09->15.39	15
F3AA40964	Pales statiques CD/EVO32 07.20-> TRAVI23 1540->	16
F3AA41390	Pochette joints gaz + vis bloc gaz TK25/ DN	17
F3AA41390	Pochette joints gaz + vis bloc gaz TK25/ DN	18
220487	Raccord TK25	19
440413	Robinet gaz 20x27	20
F3AA41478	Silencieux air 25/32 coude souple	21
440633	Support manostat HM EVO25/32 08.07->	22
425202	Tube gaz HM/P25/32/45 EVO AVL 08.08->	23
425201	Tube gaz HM25/32 EVO AMT 08.08->	24
F3AA40943	Turbine diam.12 CD20/25/32/45 EVO25/30/32/45 07.14->16.02	25
F3AA41480	Turbine diam.8 CD20/25/32/45 EVO25/30/32/45 16.03->	26

04- Circuit gaz

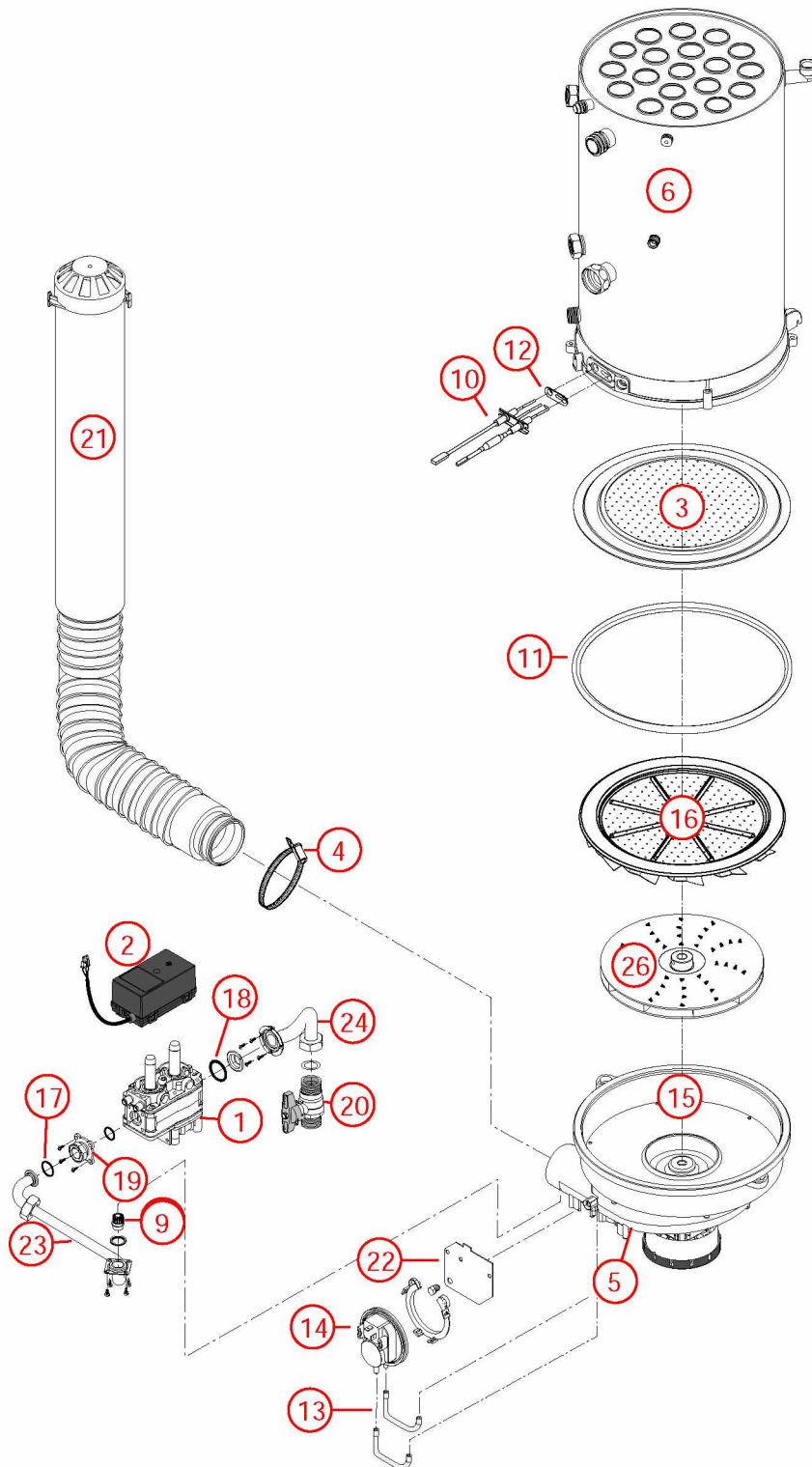

[HYDROMOTRIX EVOLUTION VISIO 32 kW@1229000->1539000]

05- Câblage / commande

REFERENCE	Pièces	N°
F3AA41254	Antenne Visio 11.50 ->	1
F3AA41273	Barre tableau de bord HMCD25/32Visio 11.50->	2
F3AA41011	Bloc gaz DN EVO 08.07->	3
F3AA41012	Bobines EV bloc gaz EVO 08.07->	4
F3AA40994	Boîtier électronique EVO25/30/32/45 08.07-> Travi23 1540->	5
F3AA41343	Câblage général HM32 EVO Visio 12.29->17.44	6
F3AA41343	Câblage général HM32 EVO Visio 12.29->17.44	7
250253	Câble adaptation transfo CD/EVO25/32/45	8
F3AA40511	Capteur de pression 2000->	9
F3AA40512	Circulateur 15/5-3 standard 00.06->15.26	10
F3AA41431	Circulateur HR 15/6 standard 15.27->	11
F3AA41207	Condensateur motoventilateur 3MF/400 V	12
F3AA41296	Cordon C.I /FAV Visio 11.50->	13
F3AA40515	CTN à clipper D:23.5 01.29->	14
F3AA40515	CTN à clipper D:23.5 01.29->	15
F3AA40959	CTN à visser 1/4 fumée CD/EVO 25/32/45 07.14-> CD20 10.35->	16
F3AA40516	CTN à visser 2000->	17
F3AA40944	Electrode AL+ION CD/EVO 25/32 07.14->	18
F3AA41212	Lot fusible 3.15A 250V (5)	19
F3AA41213	Lot fusible 4A 250V (5)	20
F3AA41021	Manostat EVO32 08.09->	21
F3AA40524	Moteur V4V 2000->	22
F3AA41020	Motoventilateur EVO32 08.09->15.39	23
F3AA41221	Satellite Visio 11.50->	24
F3AA40157	Sécurité de surchauffe 220v 94°C 94.02->	25
F3AA41260	Support mural satellite Visio 11.50->	26
F3AA41253	Tableau de bord Visio 11.50 ->	27
F3AA40848	Transfo allumage CD20/25/32/45 05.37-> EVO25/32 08.08->	28

[HYDROMOTRIX EVOLUTION VISIO 32 kW@1229000->1539000]

05- Câblage / commande

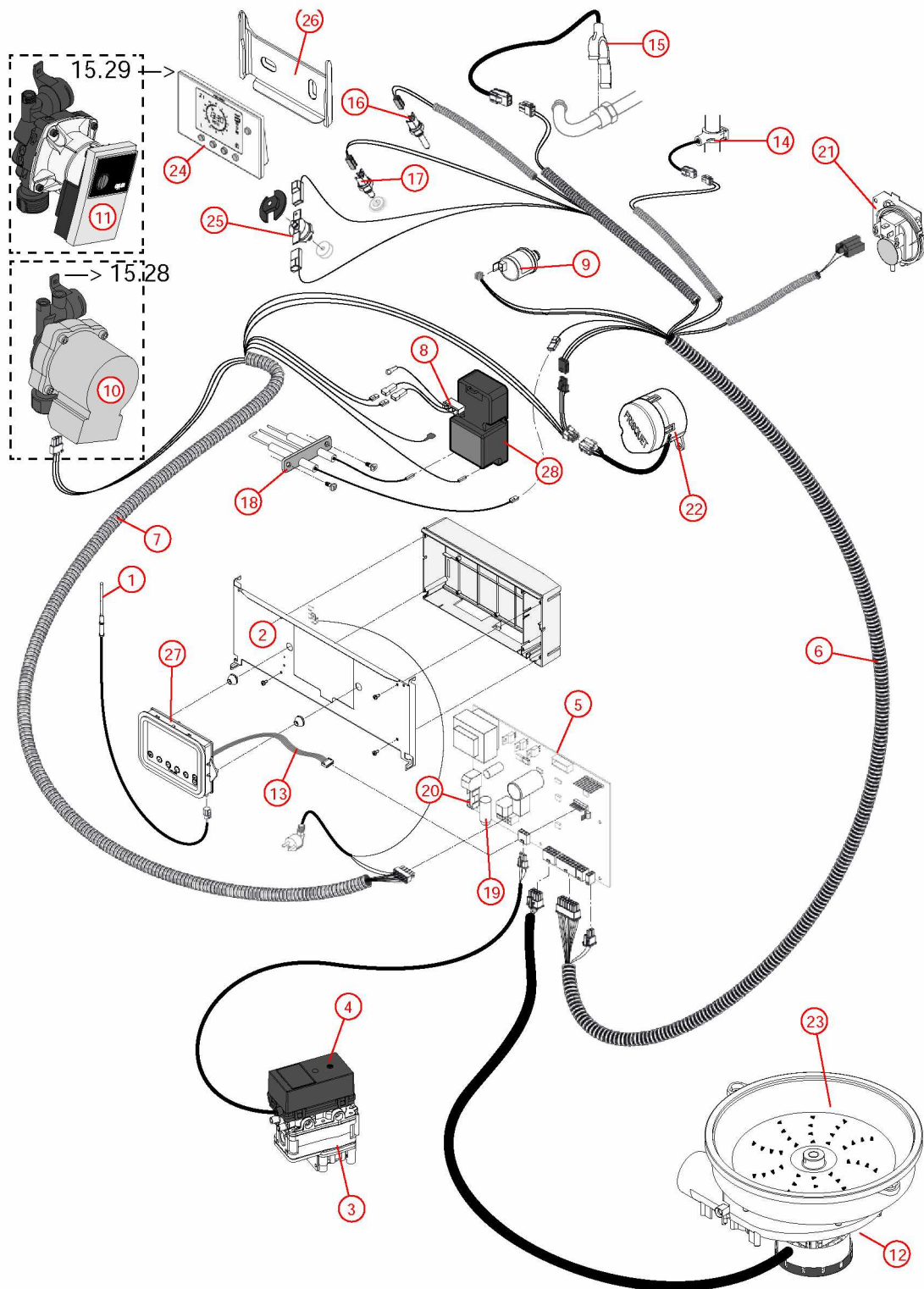

[HYDROMOTRIX EVOLUTION VISIO 32 kW@1229000->1539000]

07-Module Hydraulique

REFERENCE	Pièces	N°
F3AA41251	Boîtier électronique Visio SAV 11.50->	1
F3AA41263	Bouchon capteur pression	2
F3AA41265	Câblage général Module Hyd.Visio 11.50->15.26	3
F3AA41447	Câblage général Module Hyd.Visio 15.27 ->	4
F3AA41262	Capot Module Hyd. Visio	5
F3AA41255	Capteur sonde extérieure Visio	6
F3AA41436	Circulateur HR 26x34-130	7
F3AA41264	Clapet antiretour DN20	8
F3AA40515	CTN à clipper D:23.5 01.29->	9
F3AA40524	Moteur V4V 2000->	10
250314	Prise coudée câble 1.55m	11
F3AA40752	Raccord liaison recyclage 2000->	12
220546	Raccord M3/4 tournant V4V	13
220546	Raccord M3/4 tournant V4V	14
225055	Raccord tournant F3/4-F1	15
220538	Té M/M/F	16
415535	Tube départ Module Hydraulique Visio	17
F3AA40736	Vanne 4 voies 03.16->	18
F3AA40144	Vanne isolement 3/4 carré	19
F3AA40144	Vanne isolement 3/4 carré	20

[HYDROMOTRIX EVOLUTION VISIO 32 kW@1229000->1539000]
07-Module Hydraulique

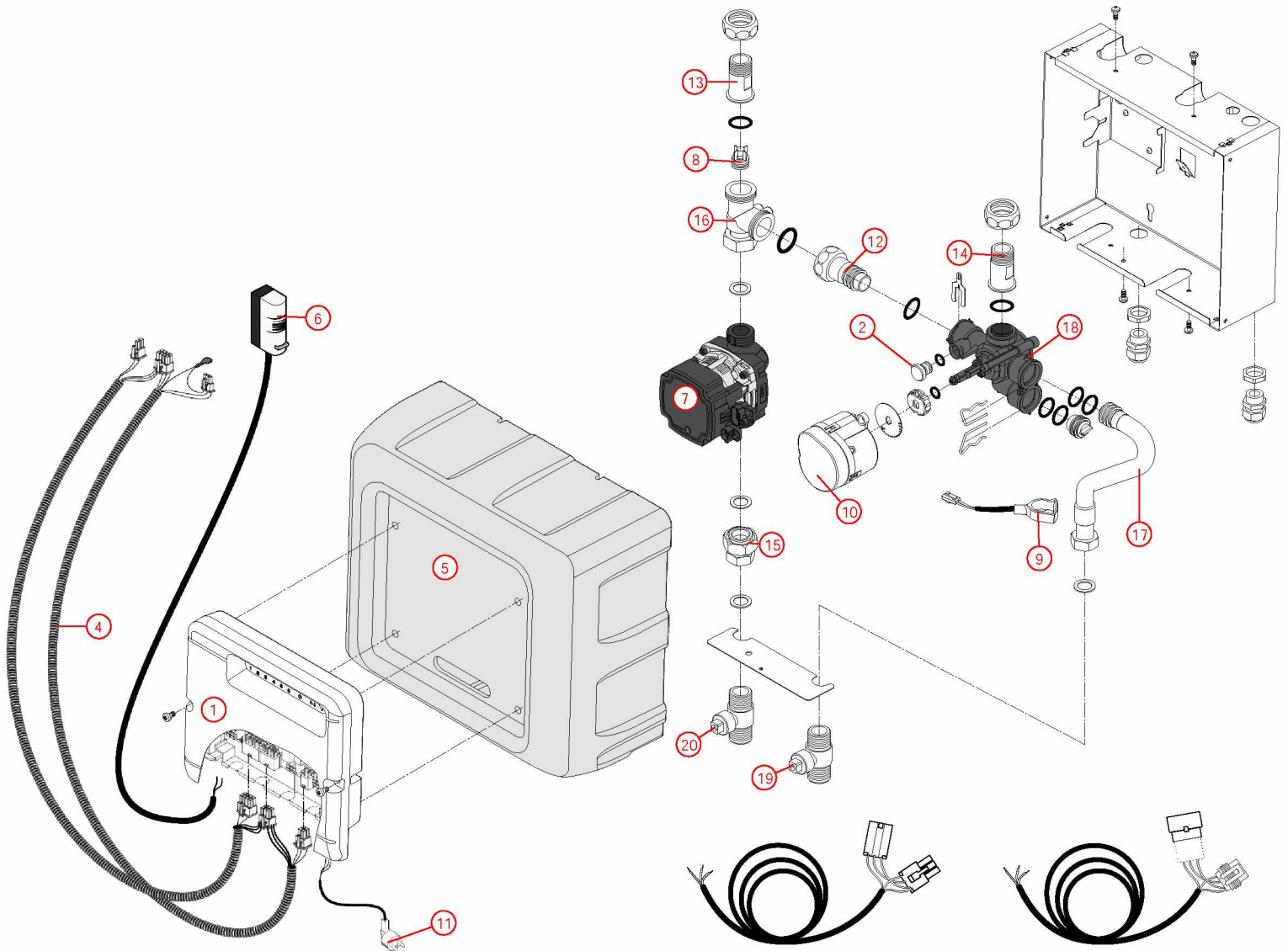

[HYDROMOTRIX EVOLUTION VISIO 32 kW@1229000->1539000]

031-2ème circuit hydraulique

REFERENCE	Pièces	N°
F3AA41442	Circulateur 33x42 HR 15.31 ->	1
F3AA40288	Circulateur 33x42 standard ->15.30	2
F3AA40836	Clapet antiretour 3/4MF	3
415437	Tube départ AMT HM EVO25/30/32 2ème circuit+circul 08.08->	4
415453	Tube départ AVL HM EVO30/32 2ème circuit+circul 08.09->	5
415573	Tube départ MH.HM32 EVO Visio 11.50->	6
415454	Tube retour HM EVO30/32 2ème circuit+circul 08.09->	7
415572	Tube retour MH.HM32 EVO Visio 11.50->	8
F3AA40144	Vanne isolement 3/4 carré	9
F3AA40144	Vanne isolement 3/4 carré	10

[HYDROMOTRIX EVOLUTION VISIO 32 kW@1229000->1539000]
031-2ème circuit hydraulique

