

[HYDROMOTRIX COMPACT VISIO 25 kW @1408000->]

01- Carénage

<b>REFERENCE</b>	<b>Pièces</b>	<b>N°</b>
F3AA41254	Antenne Visio 11.50 ->	1
430950	Barre accrochage HMC 25	2
F3AA41407	Barre de rigidité HMC25 14.08->	3
F3AA41404	Barre tableau de bord HMC25 14.08->	4
230247	Bride support CDC CD/EVO25/32 07.14->	5
F3AA41403	Châssis HMC25 14.08->	6
430700	Côté CD/EVO 25	7
430700	Côté CD/EVO 25	8
431084	Dessous HMC 14.08->	9
F3AA41405	Façade HMC25 14.08->	10

[HYDROMOTRIX COMPACT VISIO 25 kW @1408000->]

01- Carénage

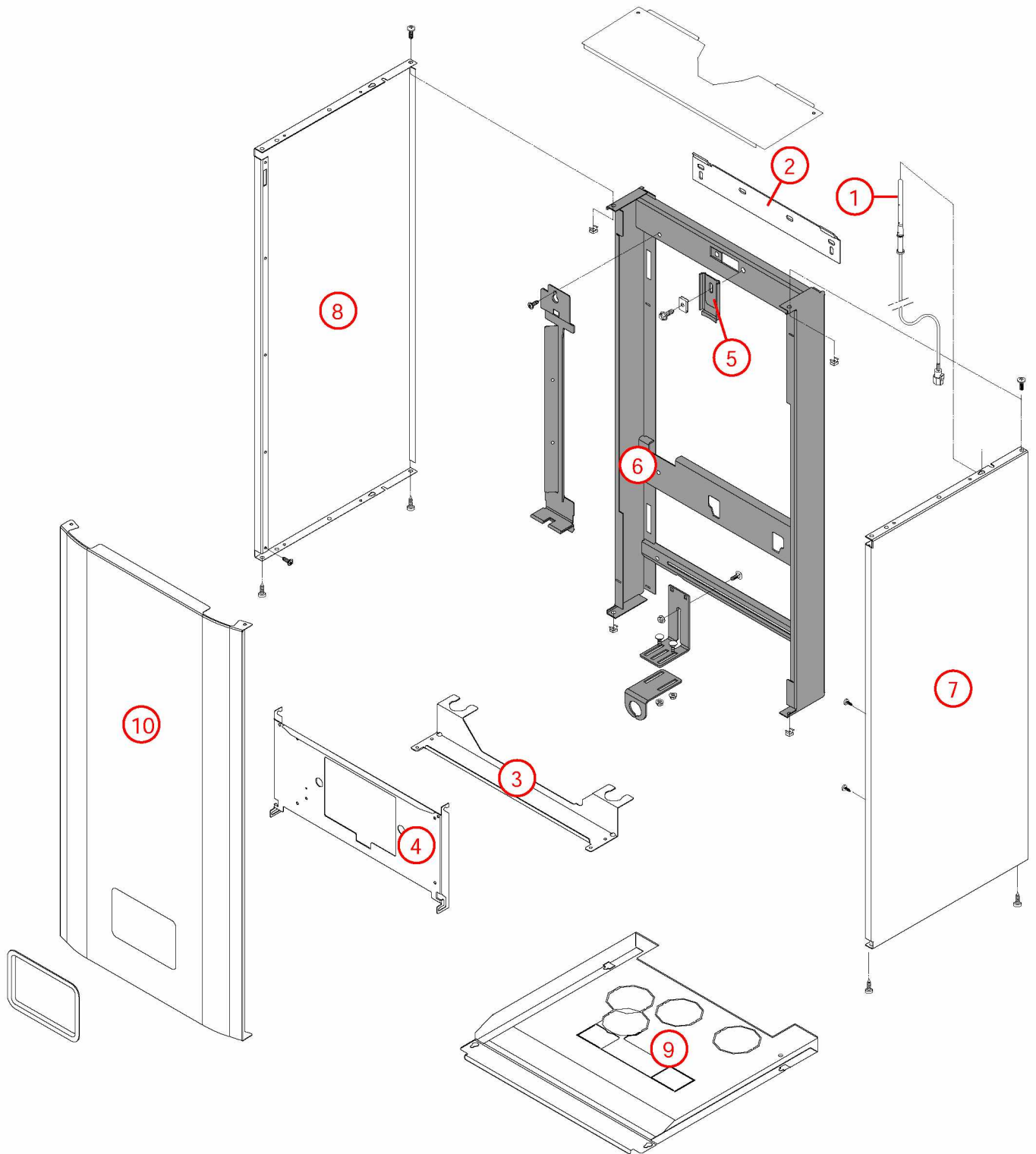

## [HYDROMOTRIX COMPACT VISIO 25 kW @1408000-&gt;]

## 02- Corps de chauffe

<b>REFERENCE</b>	<b>Pièces</b>	<b>N°</b>
450096	Calorifuge corps de chauffe HM/P EVO 25 08.08->	1
F3AA41010	Capteur fumée EVO 25/32 08.07->	2
400540	Chicane corps de chauffe CD/EVO lg 340 07.14->	3
F3AA41170	Chicanes (19) CD/EVO lg 340 07.14->	4
405401	Corps de chauffe HMC25 14.08->	5
F3AA41013	Coupe tirage dia.125 EVO25 08.07->	6
F3AA40959	CTN à visser 1/4 fumée CD/EVO 25/32/45 07.14-> CD20 10.35->	7
F3AA40945	Joint couvercle fumée CD/EVO 25/32 07.14->	8
F3AA40948	Joint de capteur de fumées CD/EVO 25/32 07.14->	9
F3AA40932	Lot tirant capteur CD/EVO 25(X3) 07.14->	10
430703	Patte support transfo. allumage HMCD/EVO25/32 07.14->	11
F3AA40790	Robinet de vidange 88.02->	12
410224	Vase rectangulaire 8L	13

[HYDROMOTRIX COMPACT VISIO 25 kW @1408000->]  
02- Corps de chauffe

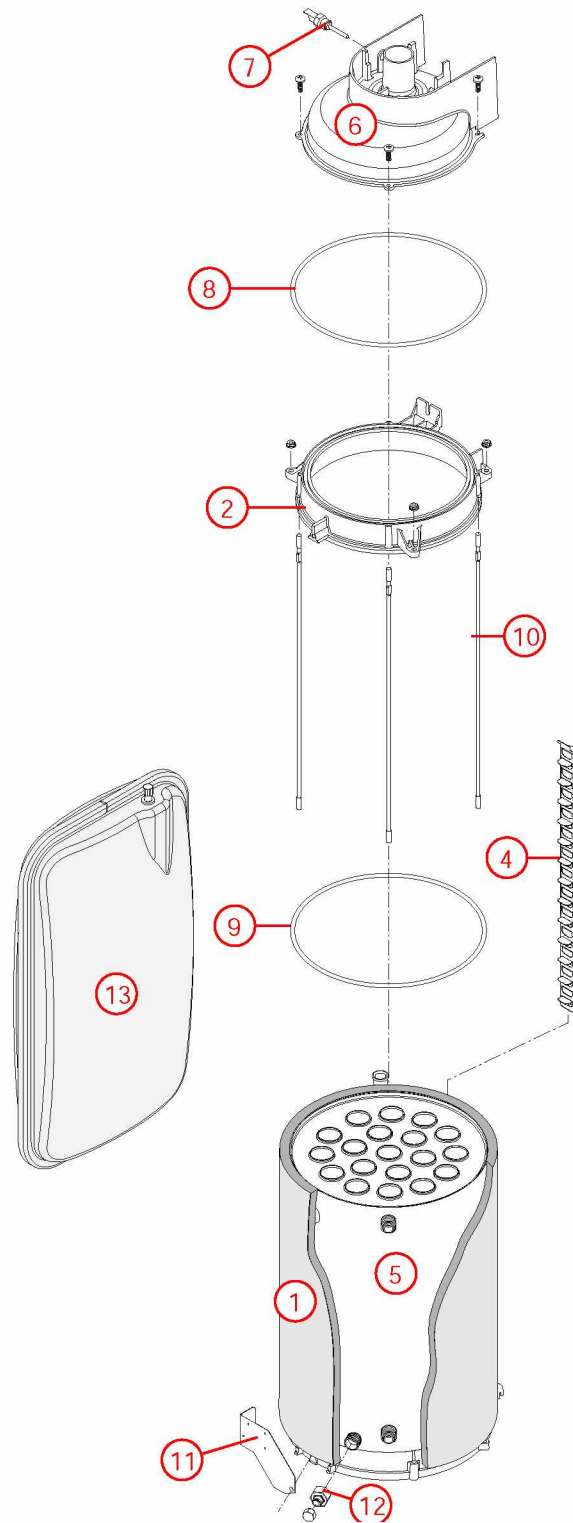

## [HYDROMOTRIX COMPACT VISIO 25 kW @1408000-&gt;]

## 03- Circuit hydraulique

REFERENCE	Pièces	N°
F3AA40511	Capteur de pression 2000->	1
F3AA40437	Cartouche thermos. RTA 98->	2
F3AA40512	Circulateur 15/5-3 standard 00.06->15.26	3
F3AA41431	Circulateur HR 15/6 standard 15.27->	4
F3AA41493	Compensateur EVO 25 C VMC 16.30->	5
405401	Corps de chauffe HMC25 14.08->	6
F3AA40515	CTN à clipper D:23.5 01.29->	7
F3AA40515	CTN à clipper D:23.5 01.29->	8
F3AA40521	Disconnecteur + 2 vannes arrêt 00.09->	9
220535	Flexible inox DN12 lg 230 FF1/2	10
220536	Flexible inox DN12 lg 470 FF1/2	11
220403	Flexible lg 640 F1/4 F1/4 cou 03.24-> (remplissage)	12
220403	Flexible lg 640 F1/4 F1/4 cou 03.24-> (remplissage)	13
F3AA41414	Lot passe fil 20x28x36x2	14
F3AA41414	Lot passe fil 20x28x36x2	15
F3AA40524	Moteur V4V 2000->	16
F3AA40540	Pochette de clips + vis 00.05->	17
F3AA40851	Pochette joint CD/EVO20/25/32 05.37->	18
F3AA40121	Purgeur automatique	19
F3AA40525	Purgeur manuel 2000->	20
F3AA40752	Raccord liaison recyclage 2000->	21
F3AA41412	Raccord M3/4 départ / CTN	22
F3AA41411	Raccord M3/4 M double à gorge L60	23
F3AA40963	Régulateur débit 11L BLEU	24
F3AA40532	RTA 2000->	25
F3AA40533	Soupape rac.3b 2000->	26
F3AA41504	Tube EF Compens EVO C	27
415602	Tube départ chauffage HMC25 14.08->	28
415527	Tube EC EVO25 VMC 10->	29
415559	Tube remplissage HM25 C	30
415601	Tube retour chauffage HMC25 14.08->	31
F3AA40955	Tube soupape CD/EVO 25/32/45 07.14->	32
415603	Tube vase HMC25 14.08->	33
F3AA41435	Vanne 3/4 MM alésé 20.2	34
F3AA41435	Vanne 3/4 MM alésé 20.2	35
F3AA40736	Vanne 4 voies 03.16->	36
410224	Vase rectangulaire 8L	37

[HYDROMOTRIX COMPACT VISIO 25 kW @1408000->]

03- Circuit hydraulique

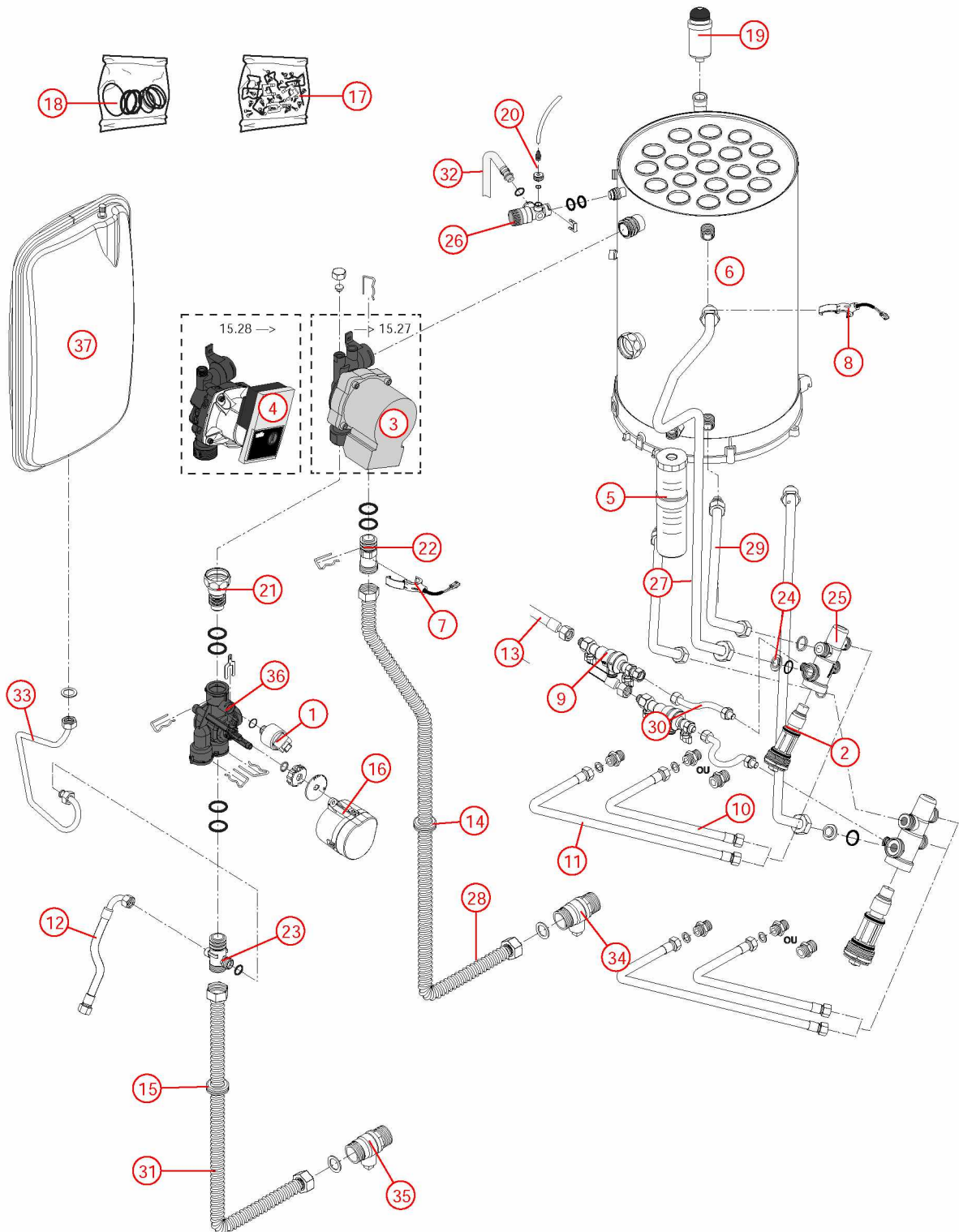

## [HYDROMOTRIX COMPACT VISIO 25 kW @1408000-&gt;]

04- Circuit gaz 1408000 -&gt;1451000

REFERENCE	Pièces	N°
F3AA41011	Bloc gaz DN EVO 08.07->	1
F3AA41012	Bobines EV bloc gaz EVO 08.07->	2
F3AA40929	Brûleur + jt CD/EVO25 07.14->	3
230167	Collier pour flexible air HV23 97.23->	4
F3AA41207	Condensateur motoventilateur 3MF/400 V	5
405401	Corps de chauffe HMC25 14.08->	6
F3AA41017	Diaphragme gaz GN 460 EVO25 08.07->18.52	7
F3AA41018	Diaphragme gaz GR 510 EVO25 08.08->18.52	8
F3AA40944	Electrode AL+ION CD/EVO 25/32 07.14->	9
220544	Flexible gaz NF36-121 lg 500	10
F3AA41006	Hublot CD/EVO	11
F3AA40950	Joint brûleur CD/EVO 25/32/45 07.14-> CD20 10.35->	12
F3AA41248	Lot joints électrode CD/EVO 05.37-> (5)	13
F3AA41070	Lot tubes pression manostat EVO	14
F3AA41511	Lot vis M 6x20	15
F3AA41015	Manostat EVO25 08.07->	16
F3AA41014	Motoventilateur EVO25 08.07->16.03	17
F3AA40933	Pales statiques EVO25 07.14->18.52 CD25 07.14->	18
F3AA41390	Pochette joints gaz + vis bloc gaz TK25/ DN	19
F3AA41390	Pochette joints gaz + vis bloc gaz TK25/ DN	20
F3AA41413	Raccord M3/4 F3/4 pression	21
220487	Raccord TK25	22
F3AA41477	Silencieux air 23/25 coude rigide	23
440741	Support manostat HMC25 14.08->	24
425242	Tube gaz EVO25 C Aval 11->	25
425245	Tube gaz HMC25 14.08->	26
F3AA40943	Turbine diam.12 CD20/25/32/45 EVO25/30/32/45 07.14->16.02	27
F3AA41480	Turbine diam.8 CD20/25/32/45 EVO25/30/32/45 16.03->	28

[HYDROMOTRIX COMPACT VISIO 25 kW @1408000->]  
04- Circuit gaz 1408000 ->1451000

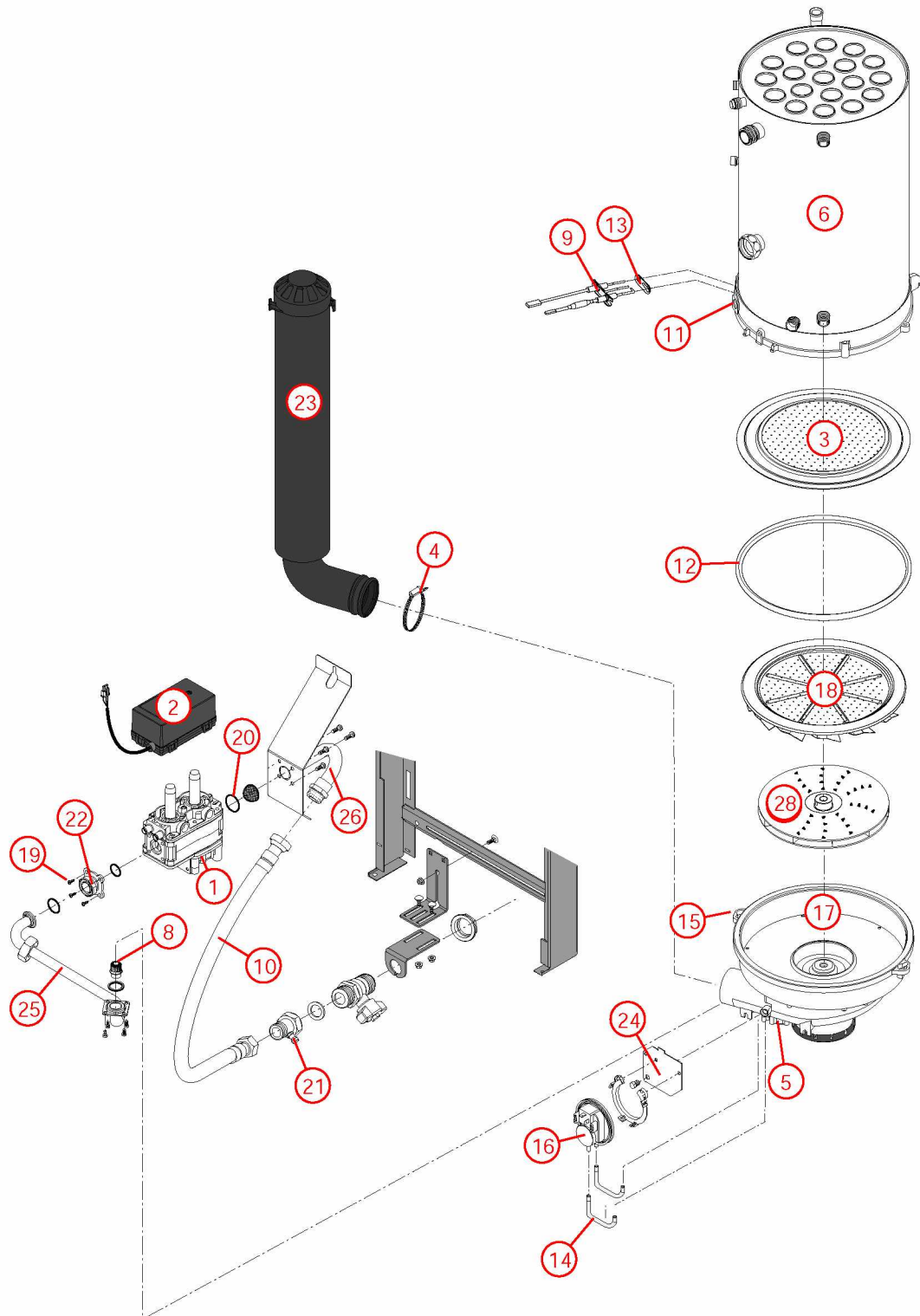



## [HYDROMOTRIX COMPACT VISIO 25 kW @1408000-&gt;]

## 04- Circuit gaz 1451000 -&gt;

REFERENCE	Pièces	N°
F3AA41011	Bloc gaz DN EVO 08.07->	1
F3AA41012	Bobines EV bloc gaz EVO 08.07->	2
F3AA40929	Brûleur + jt CD/EVO25 07.14->	3
230167	Collier pour flexible air HV23 97.23->	4
F3AA41207	Condensateur motoventilateur 3MF/400 V	5
405401	Corps de chauffe HMC25 14.08->	6
F3AA41017	Diaphragme gaz GN 460 EVO25 08.07->18.52	7
F3AA41018	Diaphragme gaz GR 510 EVO25 08.08->18.52	8
F3AA40944	Electrode AL+ION CD/EVO 25/32 07.14->	9
F3AA41423	Filtre air 395 x 131- 450	10
220544	Flexible gaz NF36-121 lg 500	11
F3AA41006	Hublot CD/EVO	12
F3AA40950	Joint brûleur CD/EVO 25/32/45 07.14-> CD20 10.35->	13
F3AA40779	Joint tube air (100)	14
F3AA41248	Lot joints électrode CD/EVO 05.37-> (5)	15
F3AA41070	Lot tubes pression manostat EVO	16
F3AA41511	Lot vis M 6x20	17
F3AA41015	Manostat EVO25 08.07->	18
F3AA41014	Motoventilateur EVO25 08.07->16.03	19
F3AA40933	Pales statiques EVO25 07.14->18.52 CD25 07.14->	20
F3AA41390	Pochette joints gaz + vis bloc gaz TK25/ DN	21
F3AA41390	Pochette joints gaz + vis bloc gaz TK25/ DN	22
F3AA41413	Raccord M3/4 F3/4 pression	23
220487	Raccord TK25	24
F3AA41477	Silencieux air 23/25 coude rigide	25
440741	Support manostat HMC25 14.08->	26
425242	Tube gaz EVO25 C Aval 11->	27
425245	Tube gaz HMC25 14.08->	28
F3AA40943	Turbine diam.12 CD20/25/32/45 EVO25/30/32/45 07.14->16.02	29
F3AA41480	Turbine diam.8 CD20/25/32/45 EVO25/30/32/45 16.03->	30

[HYDROMOTRIX COMPACT VISIO 25 kW @1408000->]  
04- Circuit gaz 1451000 ->

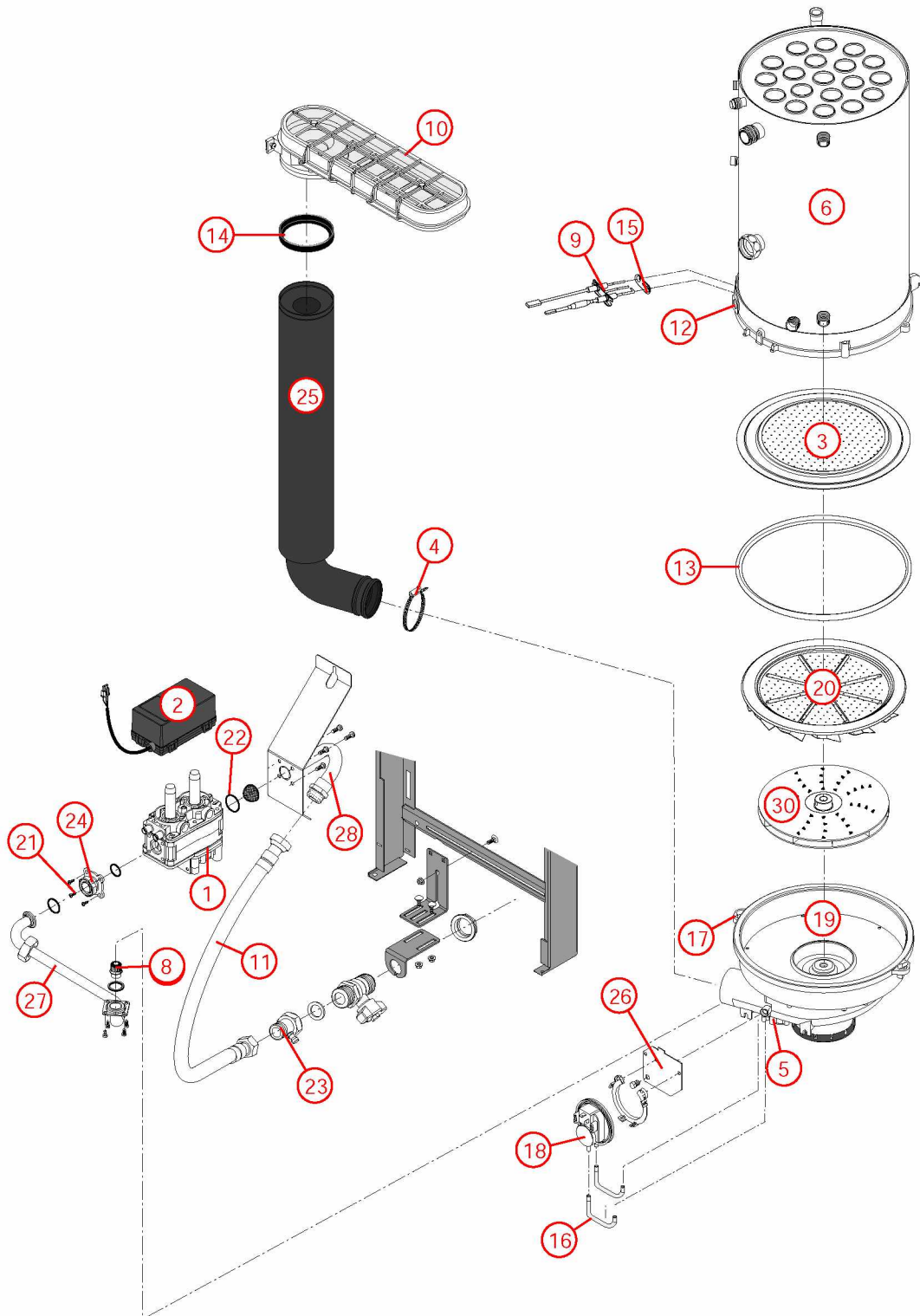

## [HYDROMOTRIX COMPACT VISIO 25 kW @1408000-&gt;]

## 04-Circuit gaz

REFERENCE	Pièces	N°
F3AA41011	Bloc gaz DN EVO 08.07->	1
F3AA41012	Bobines EV bloc gaz EVO 08.07->	2
F3AA40929	Brûleur + jt CD/EVO25 07.14->	3
230167	Collier pour flexible air HV23 97.23->	4
F3AA41207	Condensateur motoventilateur 3MF/400 V	5
F3AA41610	Corps de brûleur TRAVI 23 16.04-> EVO 25 19.01->	6
405401	Corps de chauffe HMC25 14.08->	7
F3AA41602	Diaphragme gaz GN 445 EVO25 19.01->	8
F3AA41618	Diaphragme gaz GR 500 EVO25 19.01->	9
F3AA40944	Electrode AL+ION CD/EVO 25/32 07.14->	10
F3AA41423	Filtre air 395 x 131- 450	11
220544	Flexible gaz NF36-121 lg 500	12
F3AA41006	Hublot CD/EVO	13
F3AA40950	Joint brûleur CD/EVO 25/32/45 07.14-> CD20 10.35->	14
F3AA40779	Joint tube air (100)	15
F3AA41248	Lot joints électrode CD/EVO 05.37-> (5)	16
F3AA41070	Lot tubes pression manostat EVO	17
F3AA41511	Lot vis M 6x20	18
F3AA41015	Manostat EVO25 08.07->	19
F3AA41528	Moteur turbine EVO/CD 16.03->	20
F3AA41603	Pales statiques EVO 25 19.01->	21
F3AA41390	Pochette joints gaz + vis bloc gaz TK25/ DN	22
F3AA41390	Pochette joints gaz + vis bloc gaz TK25/ DN	23
F3AA41413	Raccord M3/4 F3/4 pression	24
220487	Raccord TK25	25
F3AA41477	Silencieux air 23/25 coude rigide	26
440741	Support manostat HMC25 14.08->	27
425242	Tube gaz EVO25 C Aval 11->	28
425245	Tube gaz HMC25 14.08->	29
F3AA41480	Turbine diam.8 CD20/25/32/45 EVO25/30/32/45 16.03->	30



## [HYDROMOTRIX COMPACT VISIO 25 kW @1408000-&gt;]

## 05- Câblage / commande

REFERENCE	Pièces	N°
F3AA41254	Antenne Visio 11.50 ->	1
F3AA41404	Barre tableau de bord HMC25 14.08->	2
F3AA41011	Bloc gaz DN EVO 08.07->	3
F3AA41012	Bobines EV bloc gaz EVO 08.07->	4
F3AA40994	Boîtier électronique EVO25/30/32/45 08.07-> Travi23 1540->	5
F3AA41401	Câblage général HMC 14.08->17.52	6
F3AA41401	Câblage général HMC 14.08->17.52	7
250253	Câble adaptation transfo CD/EVO25/32/45	8
F3AA40511	Capteur de pression 2000->	9
F3AA40512	Circulateur 15/5-3 standard 00.06->15.26	10
F3AA41431	Circulateur HR 15/6 standard 15.27->	11
F3AA41207	Condensateur motoventilateur 3MF/400 V	12
F3AA41296	Cordon C.I /FAV Visio 11.50->	13
F3AA40515	CTN à clipper D:23.5 01.29->	14
F3AA40515	CTN à clipper D:23.5 01.29->	15
F3AA40959	CTN à visser 1/4 fumée CD/EVO 25/32/45 07.14-> CD20 10.35->	16
F3AA40516	CTN à visser 2000->	17
F3AA40944	Electrode AL+ION CD/EVO 25/32 07.14->	18
F3AA41212	Lot fusible 3.15A 250V (5)	19
F3AA41213	Lot fusible 4A 250V (5)	20
F3AA41015	Manostat EVO25 08.07->	21
F3AA40524	Moteur V4V 2000->	22
F3AA41014	Motoventilateur EVO25 08.07->16.03	23
F3AA41221	Satellite Visio 11.50->	24
F3AA40157	Sécurité de surchauffe 220v 94°C 94.02->	25
F3AA41260	Support mural satellite Visio 11.50->	26
F3AA41253	Tableau de bord Visio 11.50 ->	27
F3AA40848	Transfo allumage CD20/25/32/45 05.37-> EVO25/32 08.08->	28

[HYDROMOTRIX COMPACT VISIO 25 kW @1408000->]

05- Câblage / commande

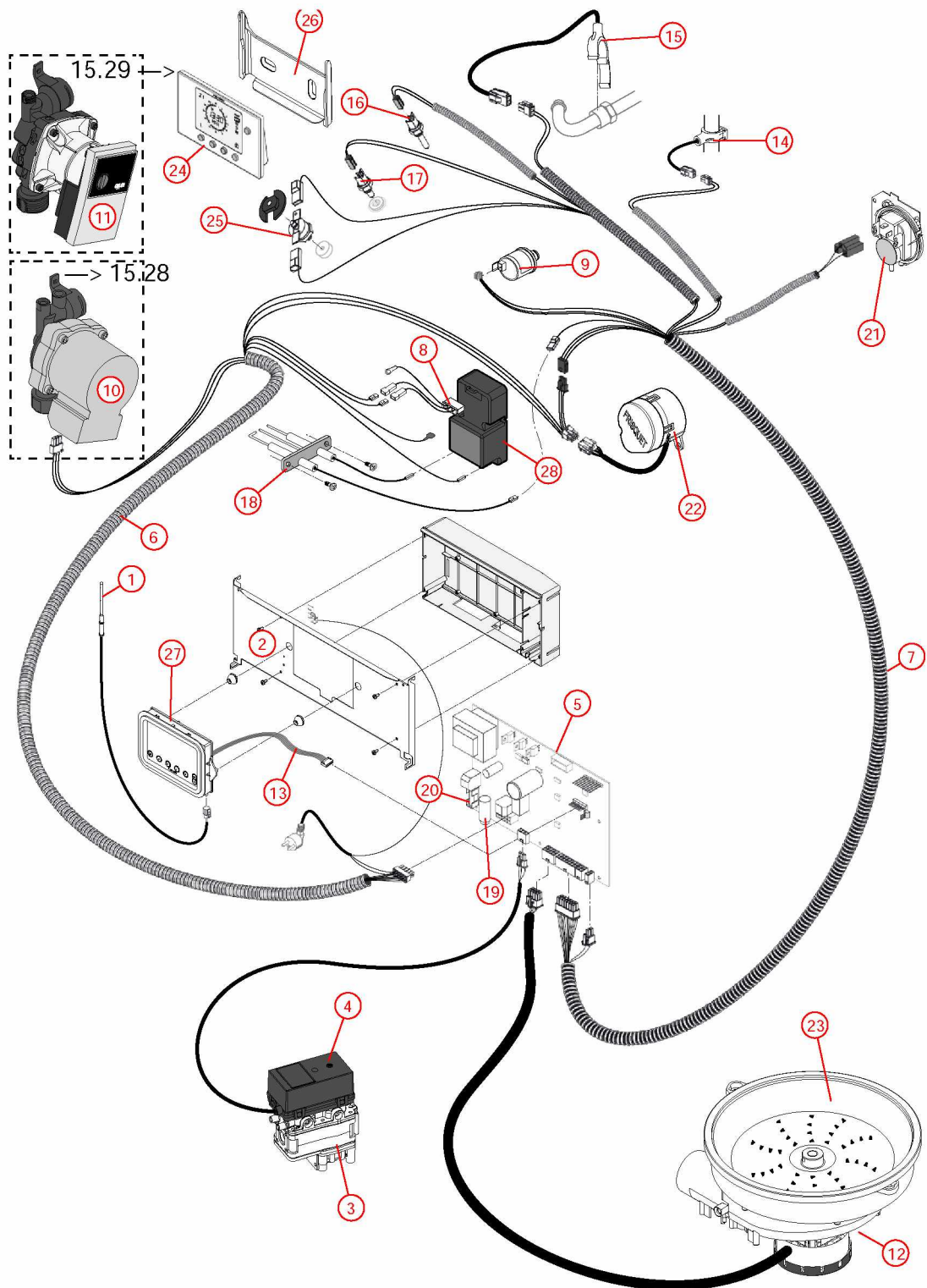

## [HYDROMOTRIX COMPACT VISIO 25 kW @1408000-&gt;]

## 5- Câblage / Commandes 1745000 -&gt;

REFERENCE	Pièces	N°
F3AA41254	Antenne Visio 11.50 ->	1
F3AA41273	Barre tableau de bord HMCD25/32Visio 11.50->	2
F3AA41011	Bloc gaz DN EVO 08.07->	3
F3AA41012	Bobines EV bloc gaz EVO 08.07->	4
F3AA40994	Boîtier électronique EVO25/30/32/45 08.07-> Travi23 1540->	5
F3AA41540	Câblage général HMC Visio 17.53->19.04	6
F3AA41540	Câblage général HMC Visio 17.53->19.04	7
F3AA41631	Câblage général HMC Visio 19.05->	8
F3AA41631	Câblage général HMC Visio 19.05->	9
250253	Câble adaptation transfo CD/EVO25/32/45	10
F3AA40511	Capteur de pression 2000->	11
F3AA41431	Circulateur HR 15/6 standard 15.27->	12
F3AA41207	Condensateur motoventilateur 3MF/400 V	13
F3AA41296	Cordon C.I /FAV Visio 11.50->	14
F3AA40515	CTN à clipper D:23.5 01.29->	15
F3AA40515	CTN à clipper D:23.5 01.29->	16
F3AA40959	CTN à visser 1/4 fumée CD/EVO 25/32/45 07.14-> CD20 10.35->	17
F3AA40516	CTN à visser 2000->	18
F3AA40944	Electrode AL+ION CD/EVO 25/32 07.14->	19
F3AA41212	Lot fusible 3.15A 250V (5)	20
F3AA41213	Lot fusible 4A 250V (5)	21
F3AA41015	Manostat EVO25 08.07->	22
F3AA40524	Moteur V4V 2000->	23
F3AA41556	Prise coudée câble 1.8m	24
F3AA41221	Satellite Visio 11.50->	25
F3AA40157	Sécurité de surchauffe 220v 94°C 94.02->	26
F3AA41260	Support mural satellite Visio 11.50->	27
F3AA41253	Tableau de bord Visio 11.50 ->	28
F3AA40848	Transfo allumage CD20/25/32/45 05.37-> EVO25/32 08.08->	29

[HYDROMOTRIX COMPACT VISIO 25 kW @1408000->]

5- Câblage / Commandes 1745000 ->

