

PRESTIGE CONDENSATION VISIO 25 KW@ 1150000->

01-Carénage / Châssis

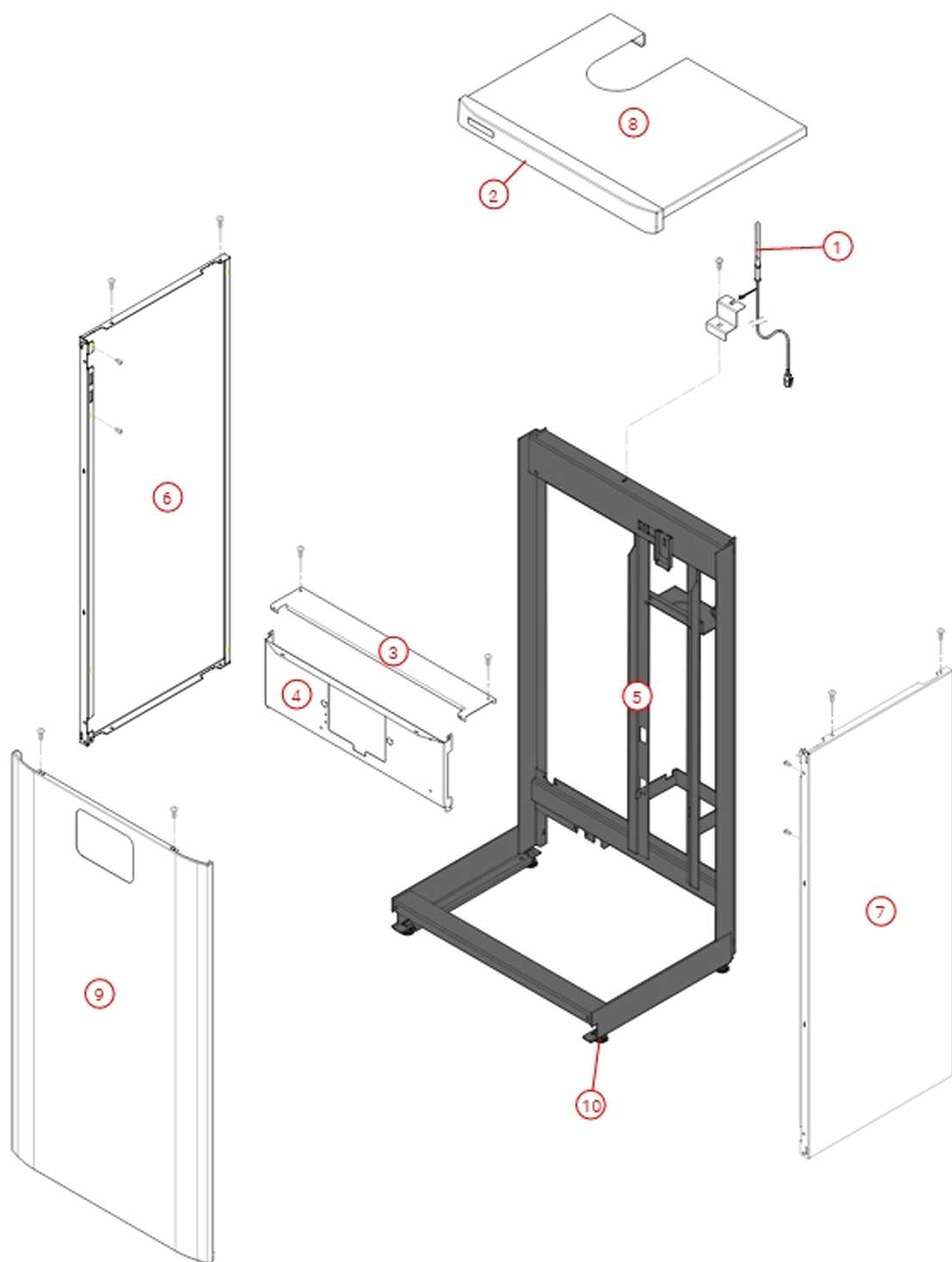

PRESTIGE CONDENSATION VISIO 25 KW@ 1150000->

01-Carénage / Châssis

PRESTIGE CONDENSATION VISIO 25 KW@ 1150000->

02-Corps de chauffe

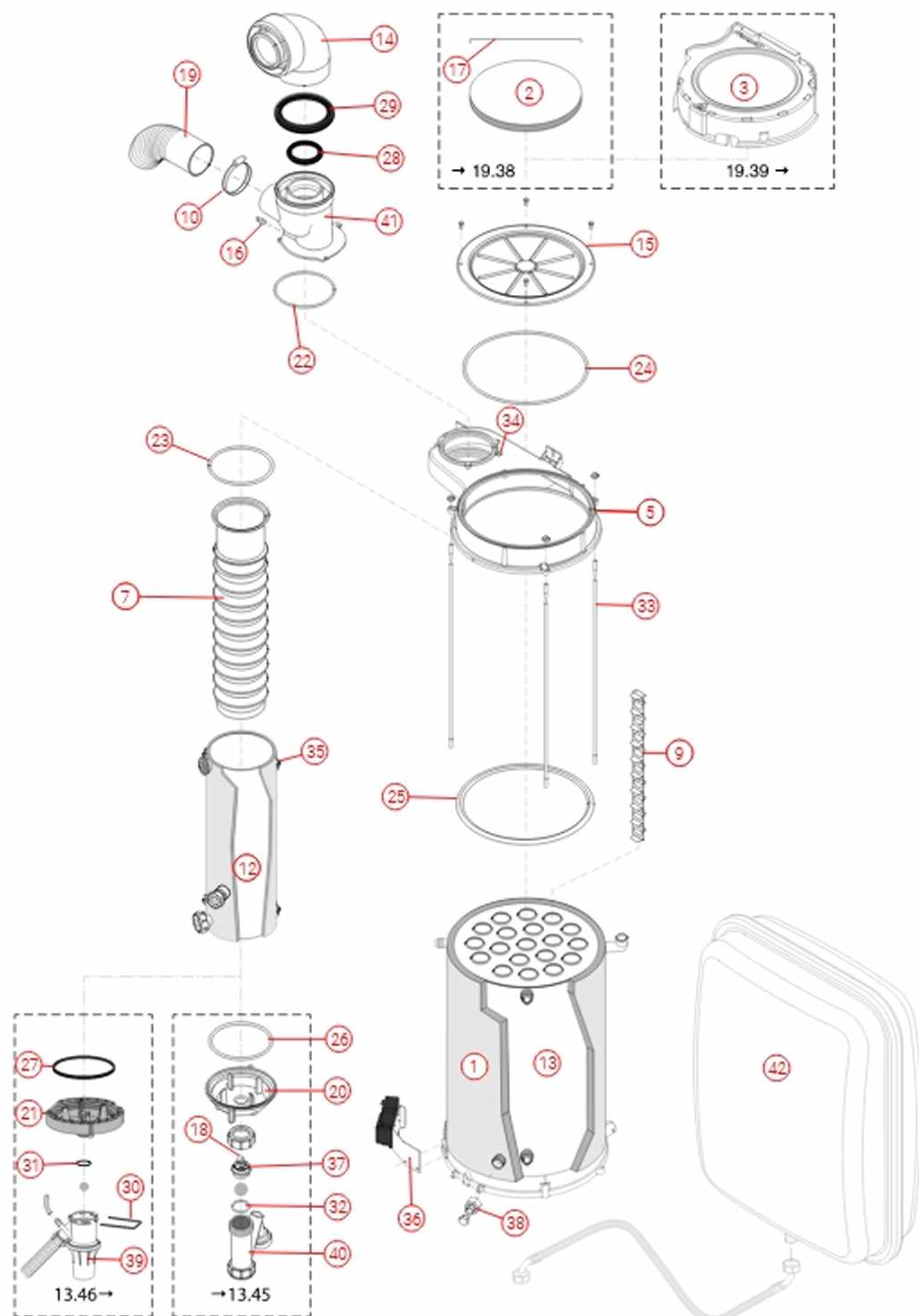

PRESTIGE CONDENSATION VISIO 25 KW@ 1150000->

02-Corps de chauffe

PRESTIGE CONDENSATION VISIO 25 KW@ 1150000->

03-Circuit hydraulique

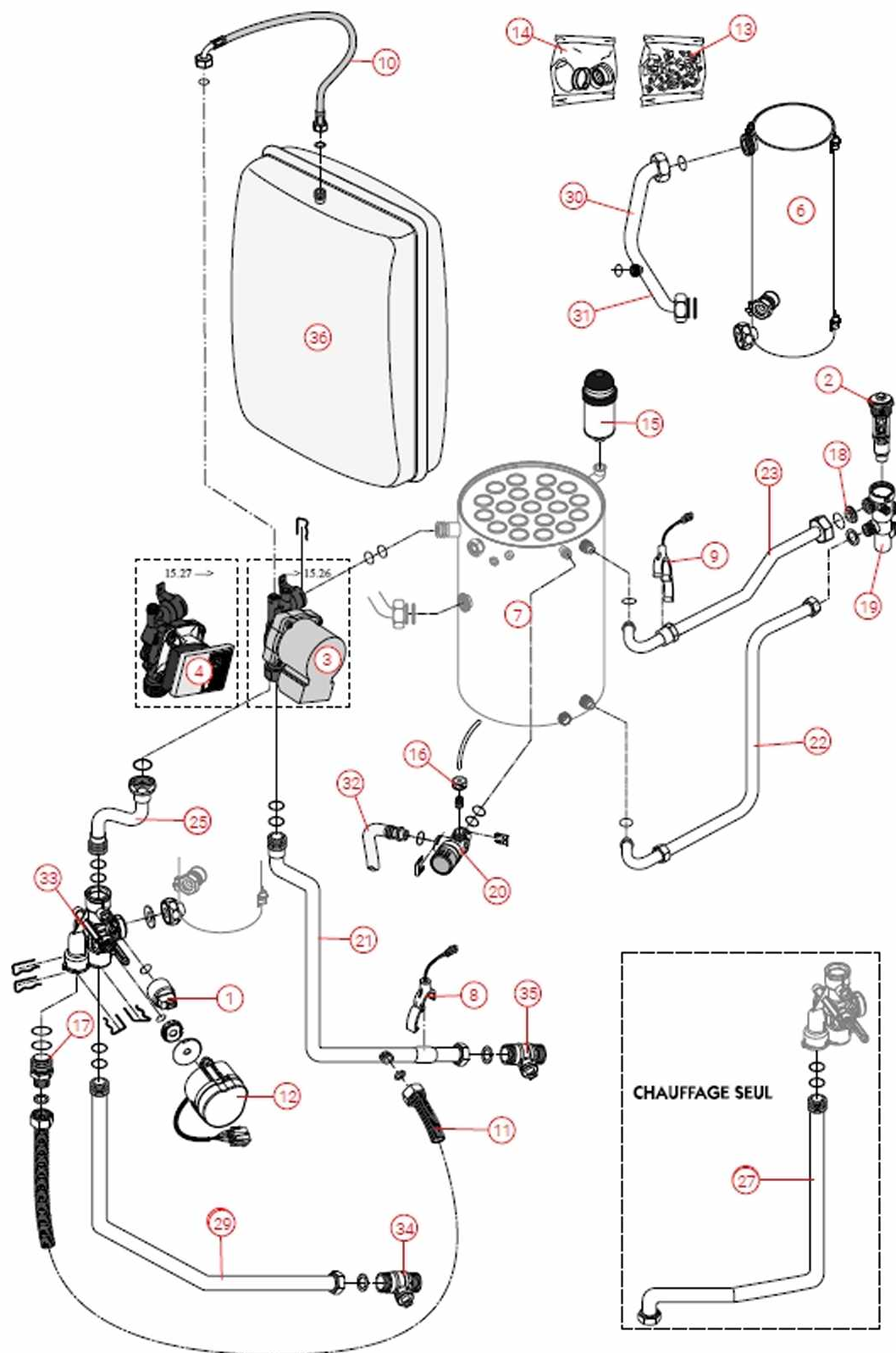

PRESTIGE CONDENSATION VISIO 25 KW@ 1150000->

031-2ème circuit hydraulique

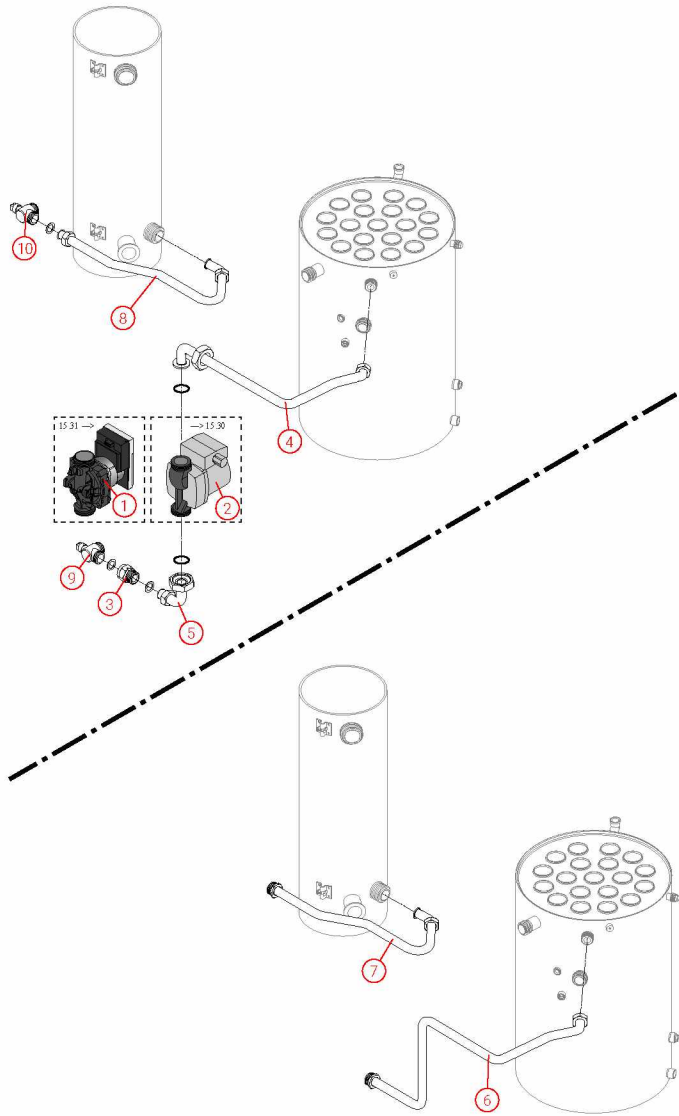

PRESTIGE CONDENSATION VISIO 25 KW@ 1150000->

04-Circuit gaz 1150000->1603000

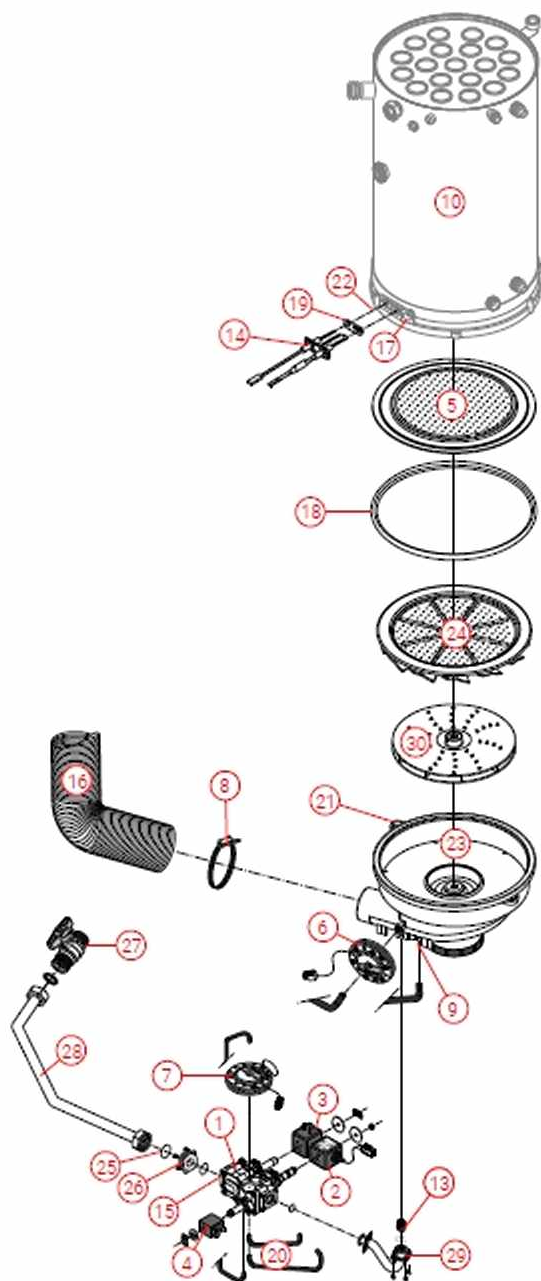

PRESTIGE CONDENSATION VISIO 25 KW@ 1150000->

04-Circuit gaz 1604000->

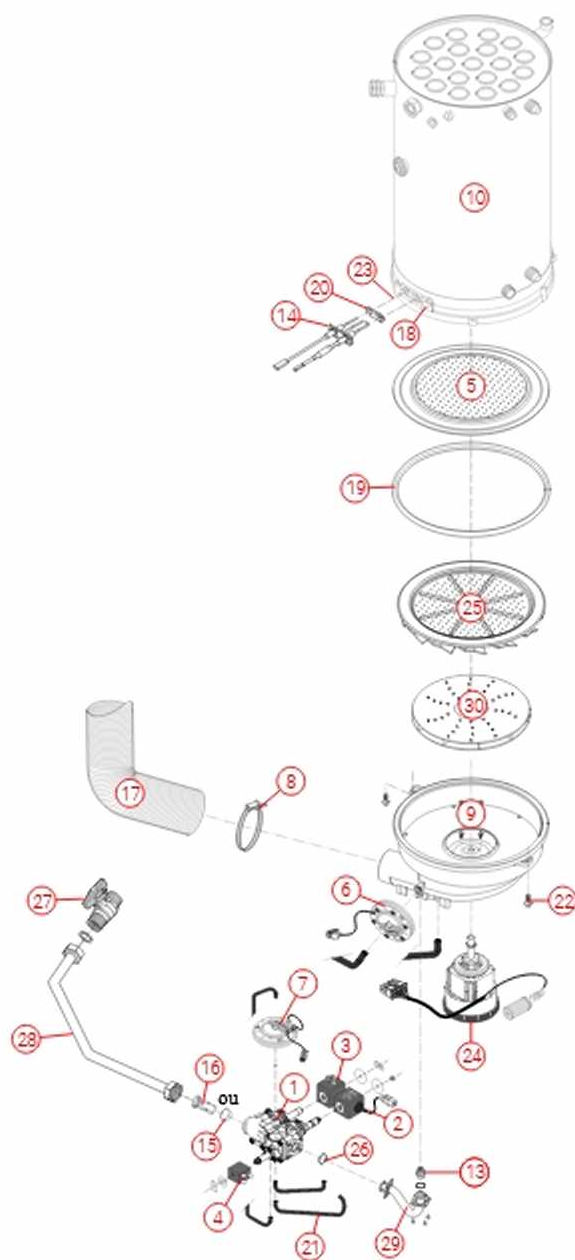

PRESTIGE CONDENSATION VISIO 25 KW@ 1150000->

04-Circuit gaz 1604000->

PRESTIGE CONDENSATION VISIO 25 KW@ 1150000->

05-Câblage / commande 1150000 -> 1744000

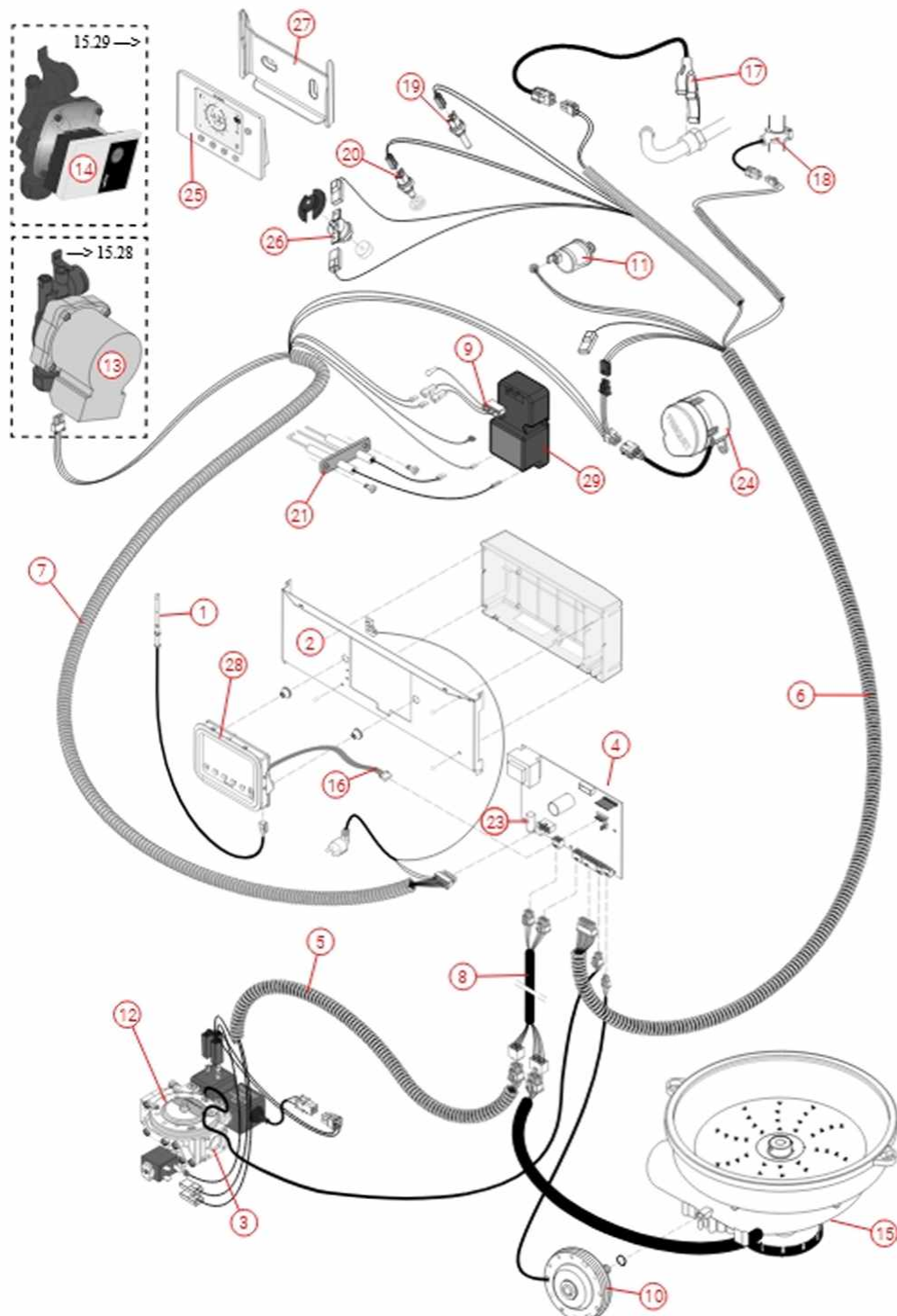

PRESTIGE CONDENSATION VISIO 25 KW@ 1150000->

05-Câblage / commande 1150000 -> 1744000

PRESTIGE CONDENSATION VISIO 25 KW@ 1150000->

05-Câblage / commande 1745000 ->

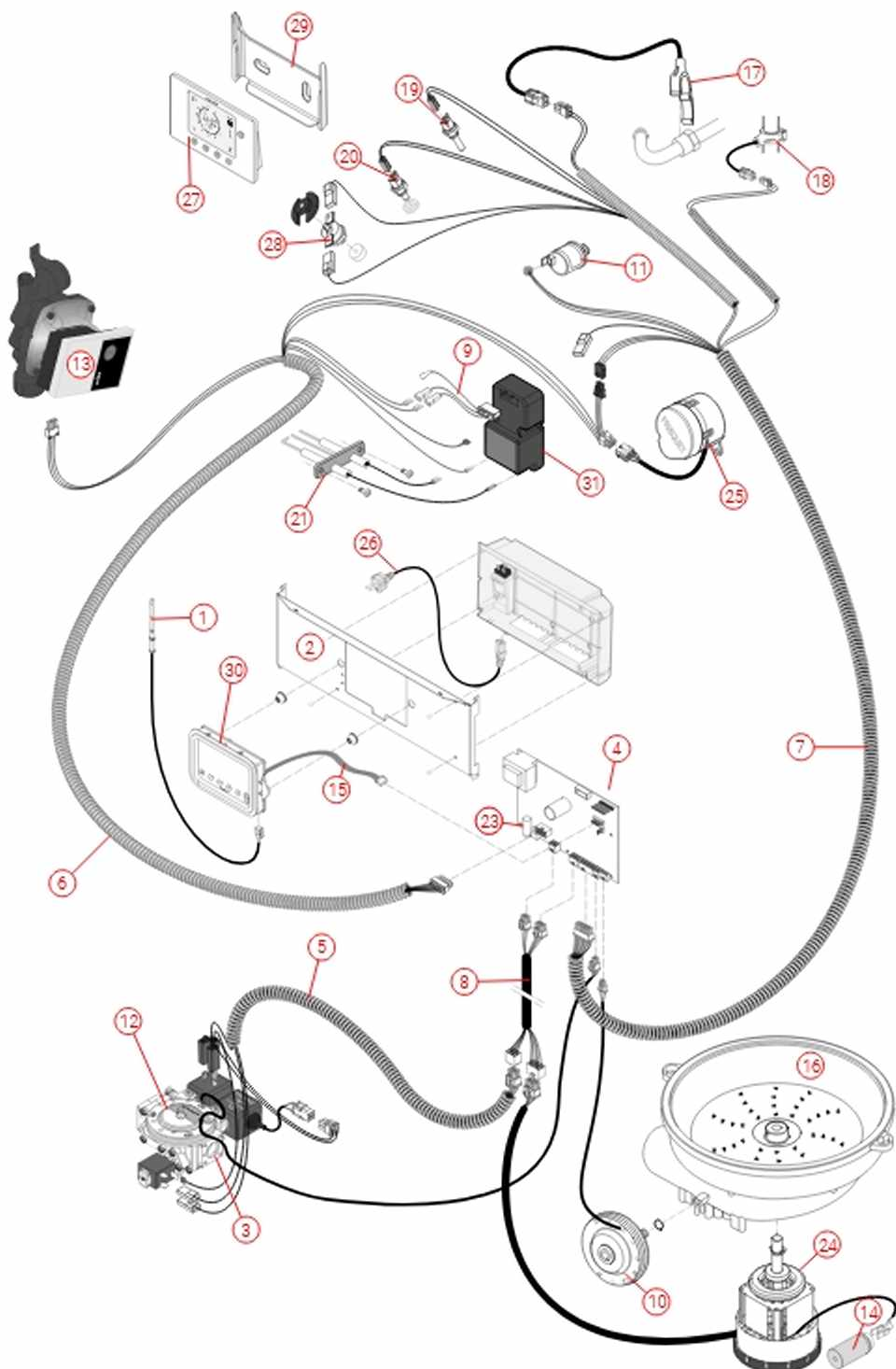

PRESTIGE CONDENSATION VISIO 25 KW@ 1150000->

05-Câblage / commande 1745000 ->

PRESTIGE CONDENSATION VISIO 25 KW@ 1150000->

06- Détail évacuation ventouse

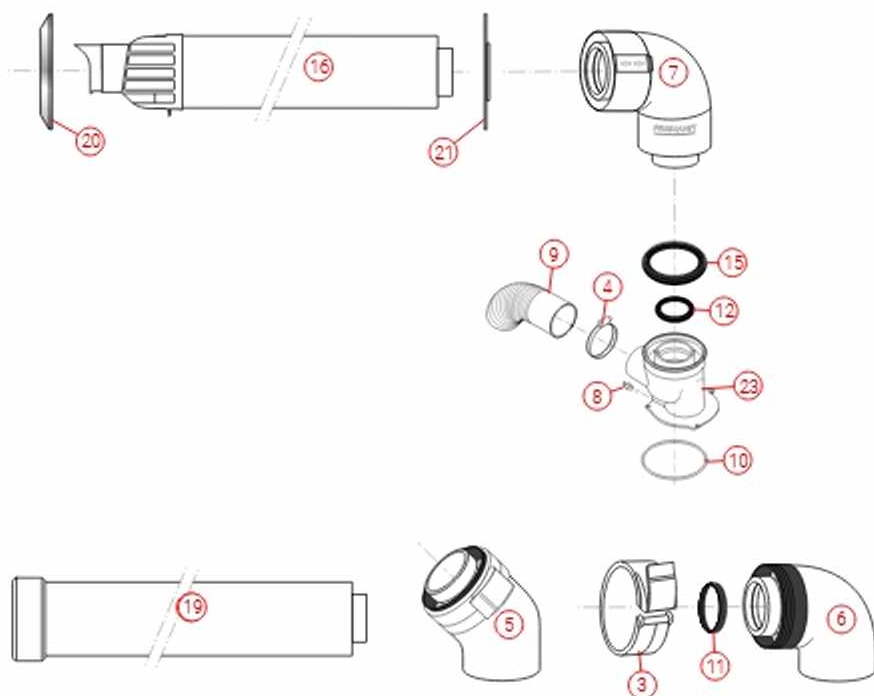

PRESTIGE CONDENSATION VISIO 25 KW@ 1150000->

06- Détail évacuation ventouse

PRESTIGE CONDENSATION VISIO 25 KW@ 1150000->

07-Module Hydraulique 1150000->2126000

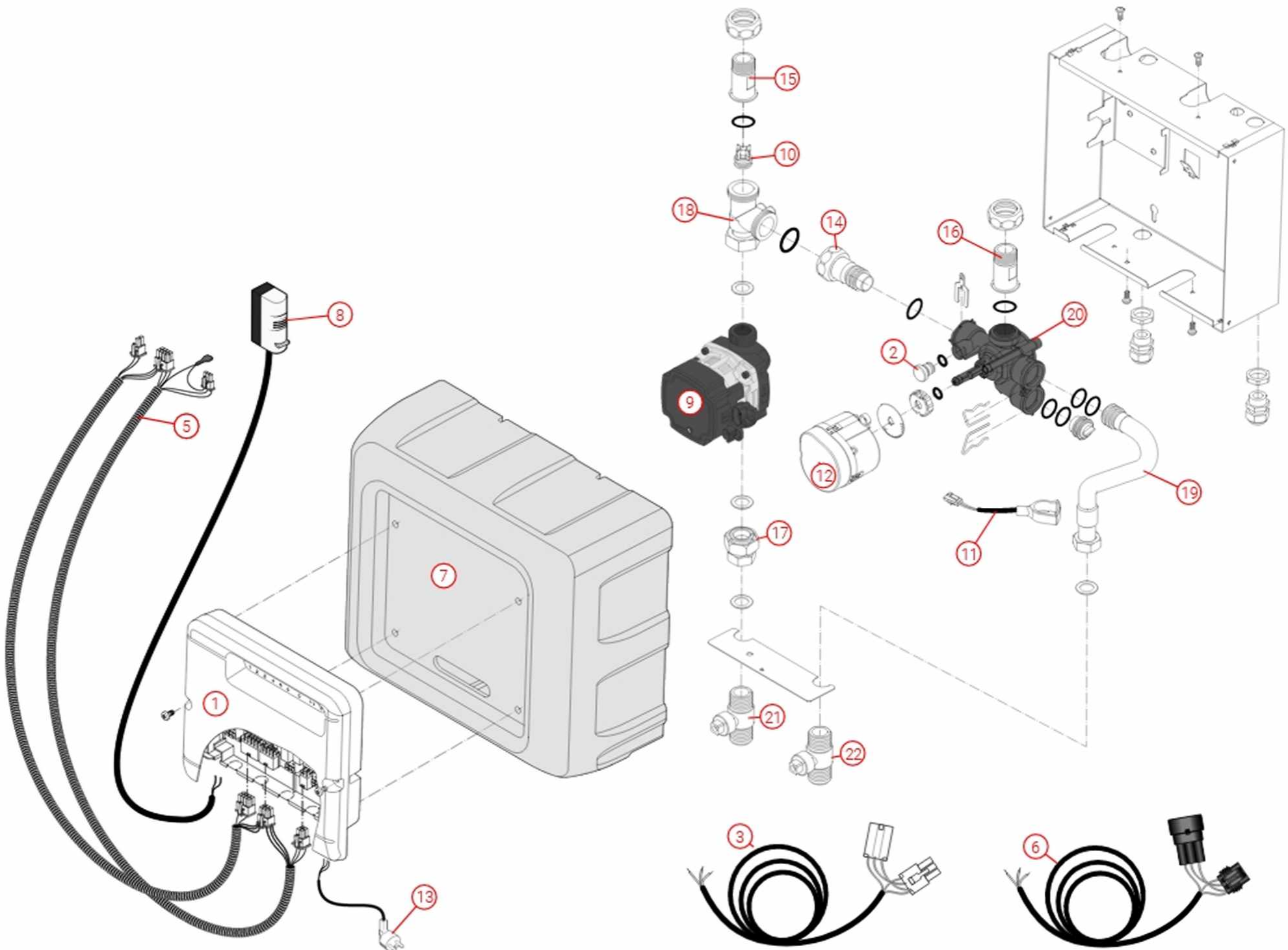

PRESTIGE CONDENSATION VISIO 25 KW@ 1150000->

07-Module Hydraulique 1150000->2126000

PRESTIGE CONDENSATION VISIO 25 KW@ 1150000->

07-Module Hydraulique 2127000->

