

SPARE PARTS EXPLODED VIEW GAS WALL BOILERS

Model

CELTIC & TIG 35 HP - FLEXIFLAME 35

R8202219-06 - 21/03/2012

1	800 227 631	CELTIC 2.35 HP CF NAT	01/96	06/06
2	217 631	CELTIC 1.35 HP CF NAT	10/94	04/95
2	800 217 631	CELTIC 1.35 HP CF NAT	01/96	06/06
3	247 631	TIG 35 HP CF NAT	11/94	09/95
3	800 247 631	TIG 35 HP CF NAT	01/96	06/06
4	800 218 631	FLEXIFLAME 35 NAT	05/96	03/97
4	800 218 631	FLEXIFLAME 35 NAT	04/97	06/06
4	800 218 621	FLEXIFLAME 35 B/P	05/96	03/97
4	800 218 621	FLEXIFLAME 35 B/P	04/97	06/06
Col	Reference	Model type	Begin	End

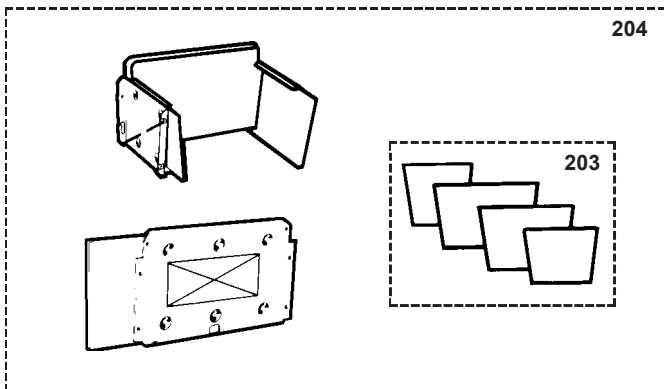
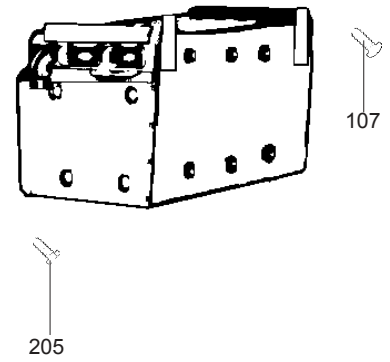
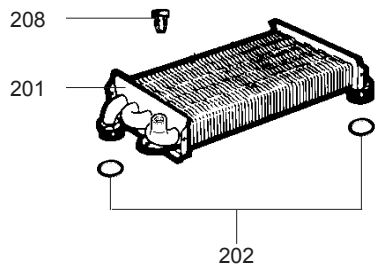
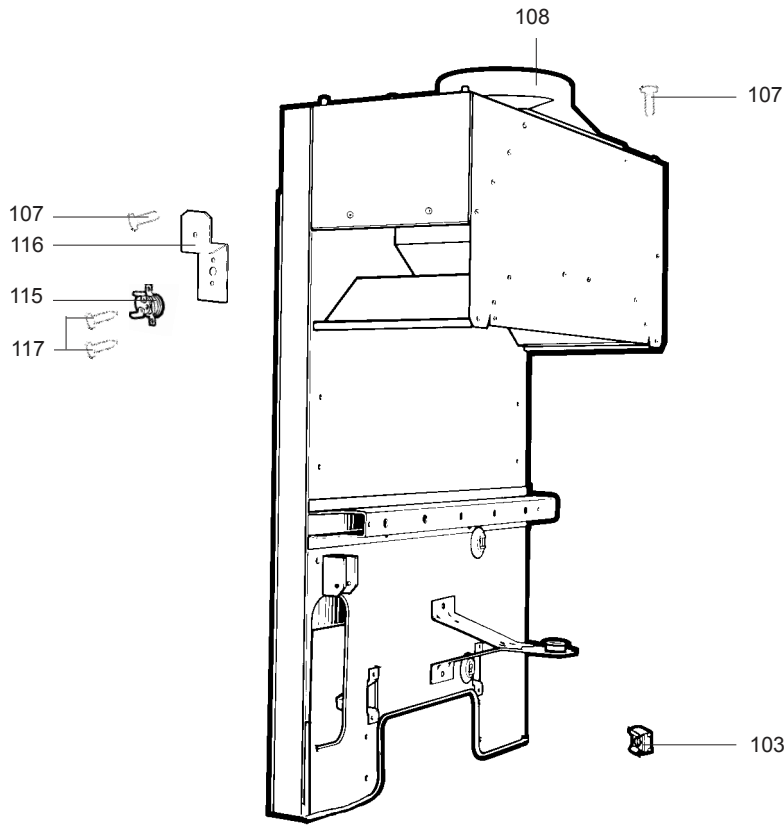

CEL TIC 2.35 HP
 CEL TIC 1.35 HP
 TIG 35 HP
 FLEXIFLAME 35

31

Description	Manf. Pt. N	Type																		
			1	2	3	4	5	6	7	8	9	10	11	12	13	14	15	16	17	18
0100 CHASSIS																				
0103 TRAPPED NUT M 6	60004806-03		•	•	•															
0107 TAPPING SCREW CBLX D: 4.2-9.5	61010125		•	•	•	•														
0108 FLUE SPIGOT	60049416		•	•	•	•														
0115 OVERHEAT THERMOSTAT 63C	61008820		•	•	•	•														
0116 SENSOR SUPPORT	61008824		•	•	•	•														
0117 TAPPING SCREW CBLZ D: 3.5-6.5	60031521-03		•	•	•	•														
0201 HEAT EXCHANGER	61014130		•	•	•	•														
0202 O-RING D: 16.1-1.6	60024184-35		•	•	•	•														
0203 COMBUSTION CHAMBER LINING KIT	60081203		•	•	•	•														
0204 COMBUSTION CHAMBER KIT	60063666		•	•	•	•														
0205 TAPPING SCREW CBLX D: 6.3-13	61010648		•	•	•	•														
0208 COVER / HEAT EXCHANGER	61015264		•	•	•	•														

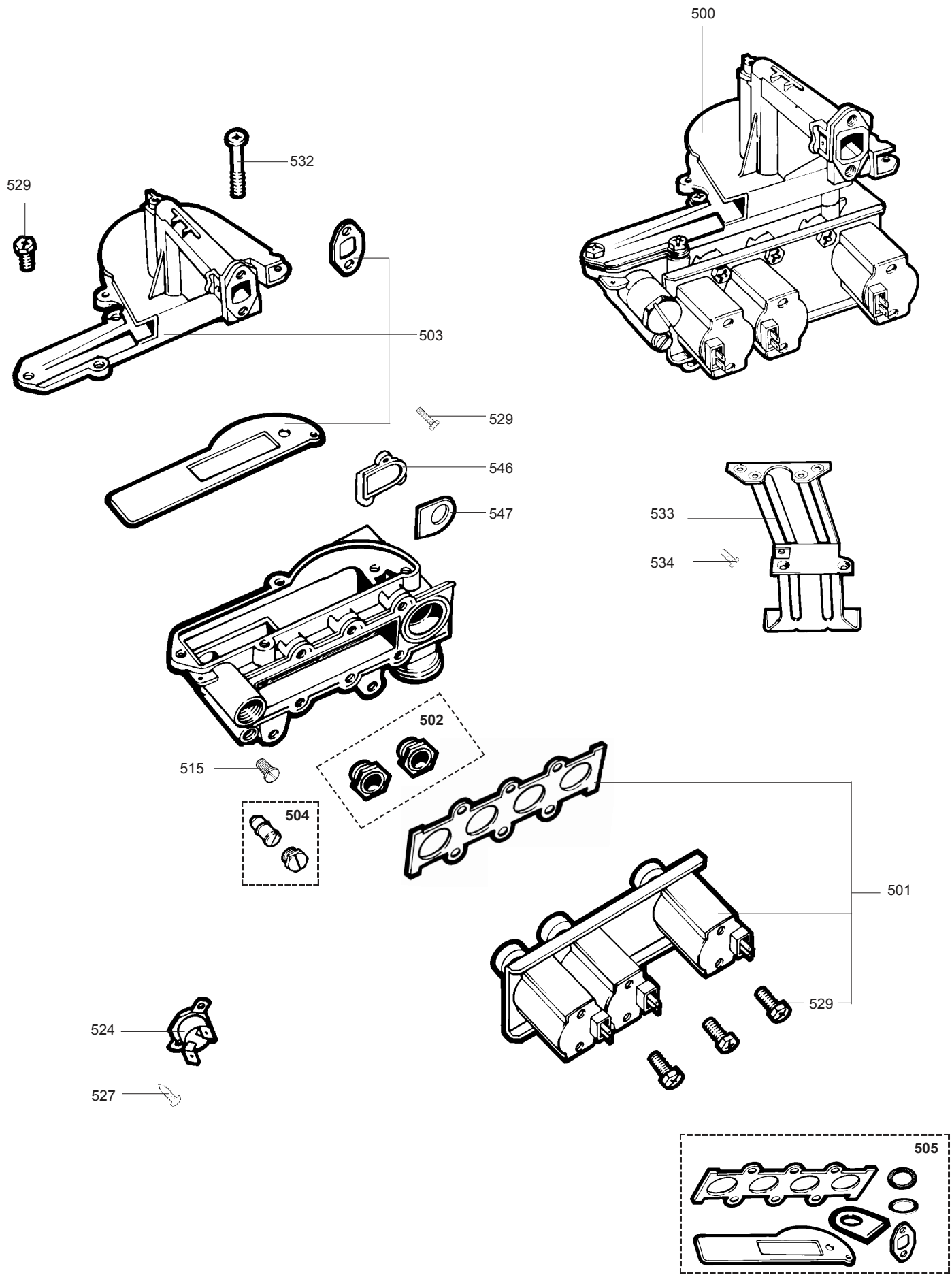

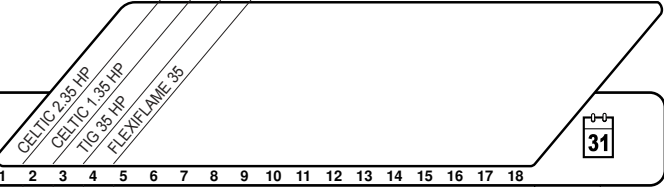

☉➔	Description	Manf. Pt. N	Type	1 2 3 4 5 6 7 8 9 10 11 12 13 14 15 16 17 18																	
				1	2	3	4	5	6	7	8	9	10	11	12	13	14	15	16	17	18
0500	GAZ SECTION NAT ASSY	61008889	NAT	●																	
0501	SOLENOID VALVES KIT	60081003		●																	
	SOLENOID VALVES KIT	60081694				●	●	●													
0502	RESTRICTORS PACK	60081580	NAT	●																	
	RESTRICTORS PACK	60081601	NAT		●	●	●														
0503	BURNER BASE KIT	60081008		●	●	●	●														
0504	ADJUSTING SCREW KIT	60081009		●	●	●	●														
0505	GAS SECTION GASKETS KIT	60081010		●	●	●	●														
0515	PRESSURE TEST POINT SCREW	60019445		●	●	●	●														
0524	OVERHEAT THERMOSTAT 110C	60070773		●	●	●	●														
0527	TAPPING SCREW CBLZ D: 3.5-6.5	60031521-03		●	●	●	●														
0529	SCREW HX M 5-12	61010131		●	●	●	●														
0532	SCREW M 5-35	60075760-03		●	●	●	●														
0533	ELECTRICAL BOX SUPPORT	60074925		●	●	●	●														
0534	TAPPING SCREW CBLX D: 6.3-13	61010648		●	●	●	●														
0546	GAS SECTION COVER	60079232		●	●	●	●														
0547	GASKET (/Cover)	60060021		●	●	●	●														

CELTIC & TIG 35 - FLEXIFLAME 35

Domestic Gas Boilers

600

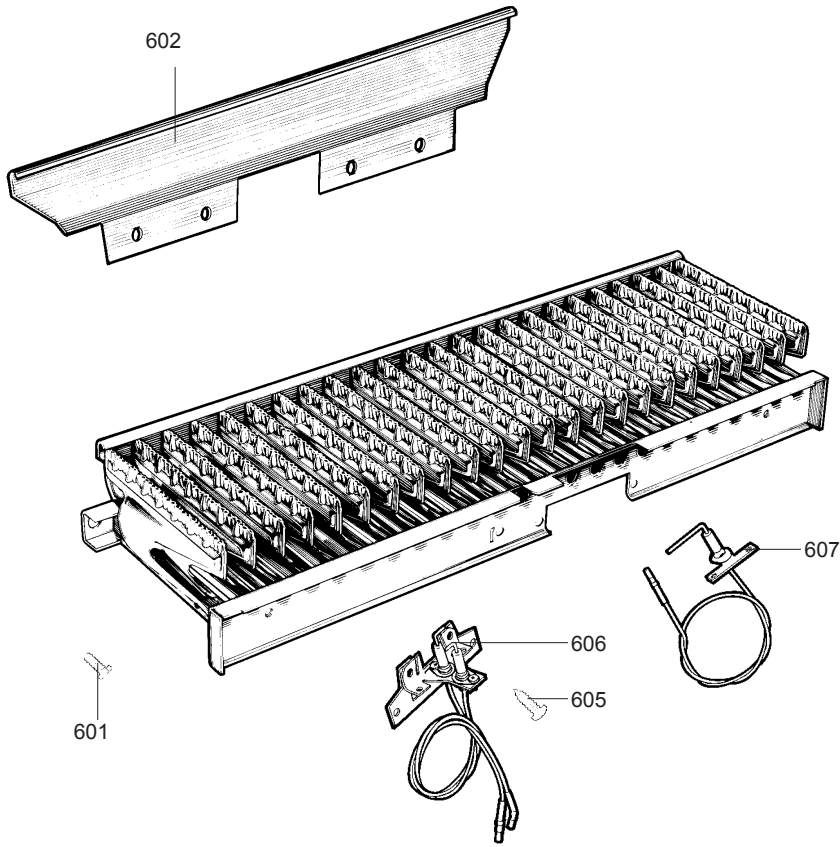

1000

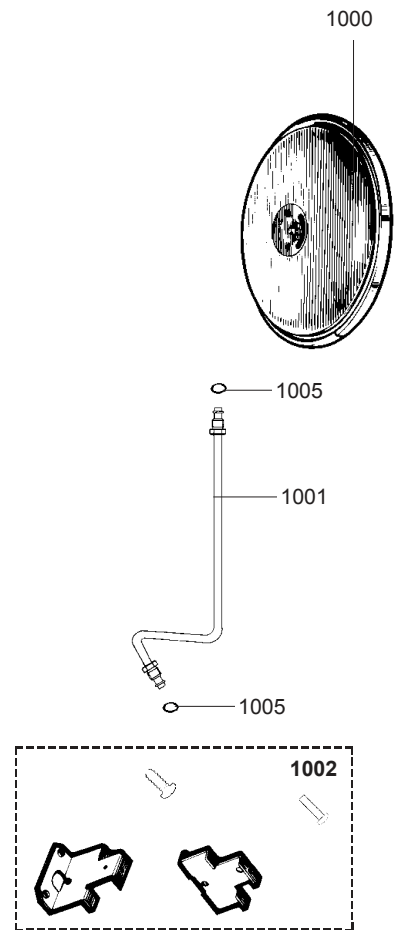

700

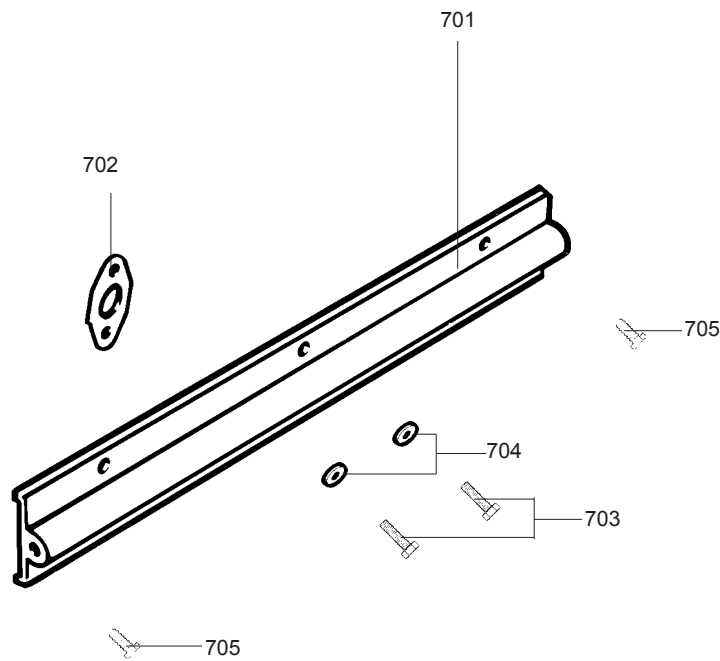

1200

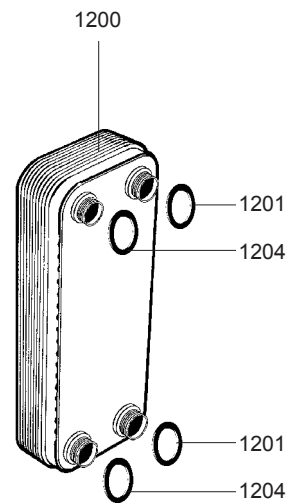

☉	Description	Manf. Pt. N	Type	<div style="display: flex; justify-content: space-between; align-items: center;"> <div style="writing-mode: vertical-rl; transform: rotate(180deg); font-size: small;"> CELTIC 235 HP CELTIC 135 HP TIG 35 HP FLEXIFLAME 35 </div> <div style="border: 1px solid black; padding: 2px;">31</div> </div>																	
				1	2	3	4	5	6	7	8	9	10	11	12	13	14	15	16	17	18
0600	BURNER HEAD																				
0601	TAPPING SCREW CBLX D: 6.3-13	61010648		•	•	•	•														
0602	CROSS LIGHTING STRIP	60039809			•	•	•												12/95		
	CROSS LIGHTING STRIP	61012221		•	•	•	•											01/96			
0605	TAPPING SCREW CBLZ D: 3.5-6.5	60031521-03		•	•	•	•														
0606	IGNITION ELECTRODE	61002801		•	•	•	•											01/96			
	IGNITION ELECTRODE ASSY	61004019			•	•	•												12/95		
0607	IONIZATION ELECTRODE ASSY	60078258			•	•	•												12/95		
	IONIZATION ELECTRODE ASSY	61011356		•	•	•	•											01/96			
0700	MANIFOLD																				
0701	MANIFOLD 24 INJ. LPG	61004809	B/P					•													
0702	GASKET (/Manifold)	60071226		•	•	•	•														
0703	SCREW HX M 5-12	61010131		•	•	•	•														
0704	WASHER D: 12-5.2-1	60061934-03		•	•	•	•														
0705	TAPPING SCREW CBLX D: 4.2-25	61010128		•	•	•	•														
1000	EXPANSION VESSEL																				
1001	EXPANSION VESSEL TUBE	60056676-06		•	•	•	•														
1002	EXPANSION VESSEL SUPPORT KIT	60053368		•	•	•	•														
1005	O-RING D: 6-1	60081014		•	•	•	•														
		60024164-41		•	•	•	•														
1200	WATER / WATER HEAT EXCHANGER																				
1201	SHEET GASKET D: 24-16.2-1.5	61008944		•																	
1202		60061855-02		•																	
1204	O-RING D: 16-1.9	60024183-37		•																	

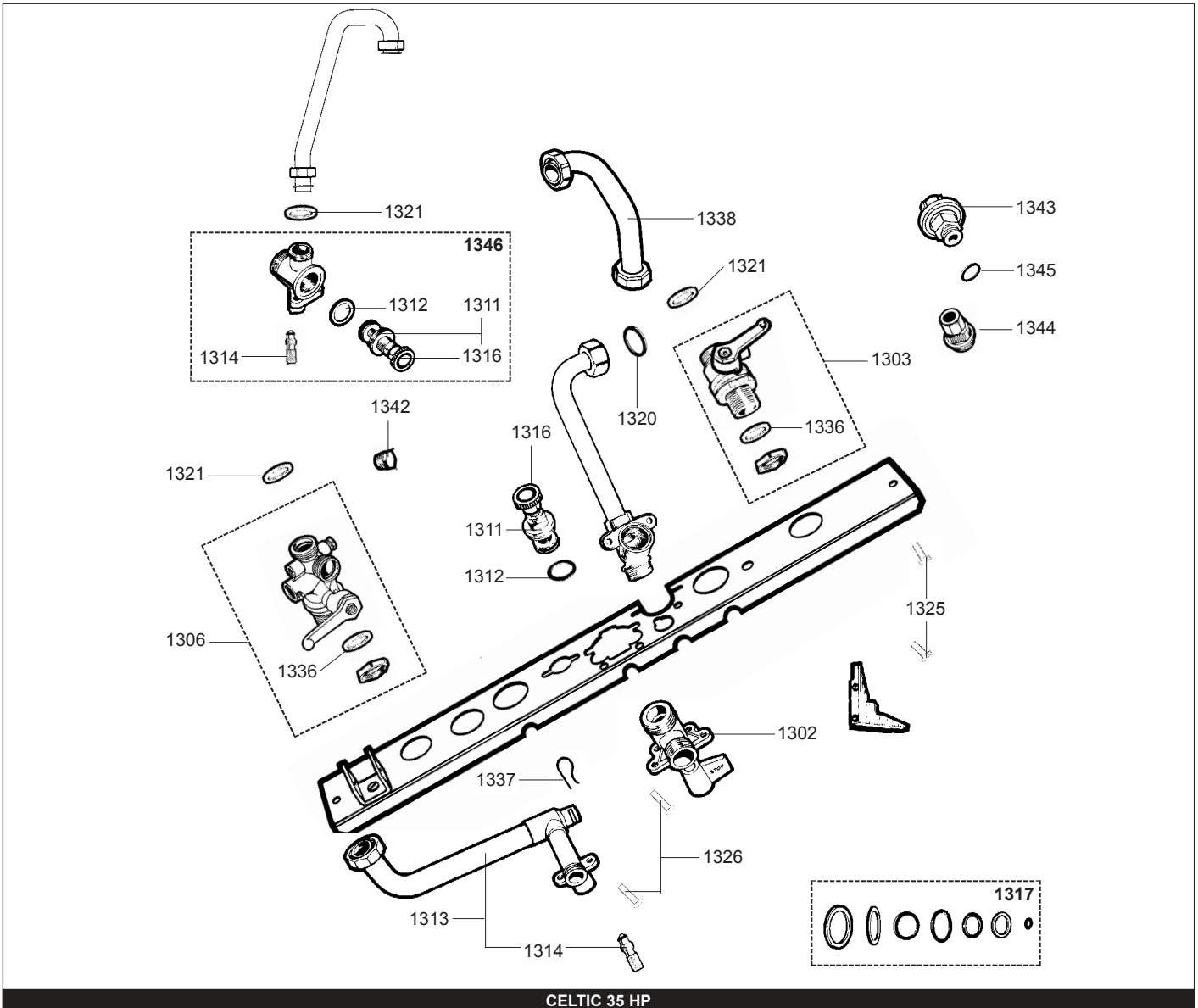

CELTIC 35 HP

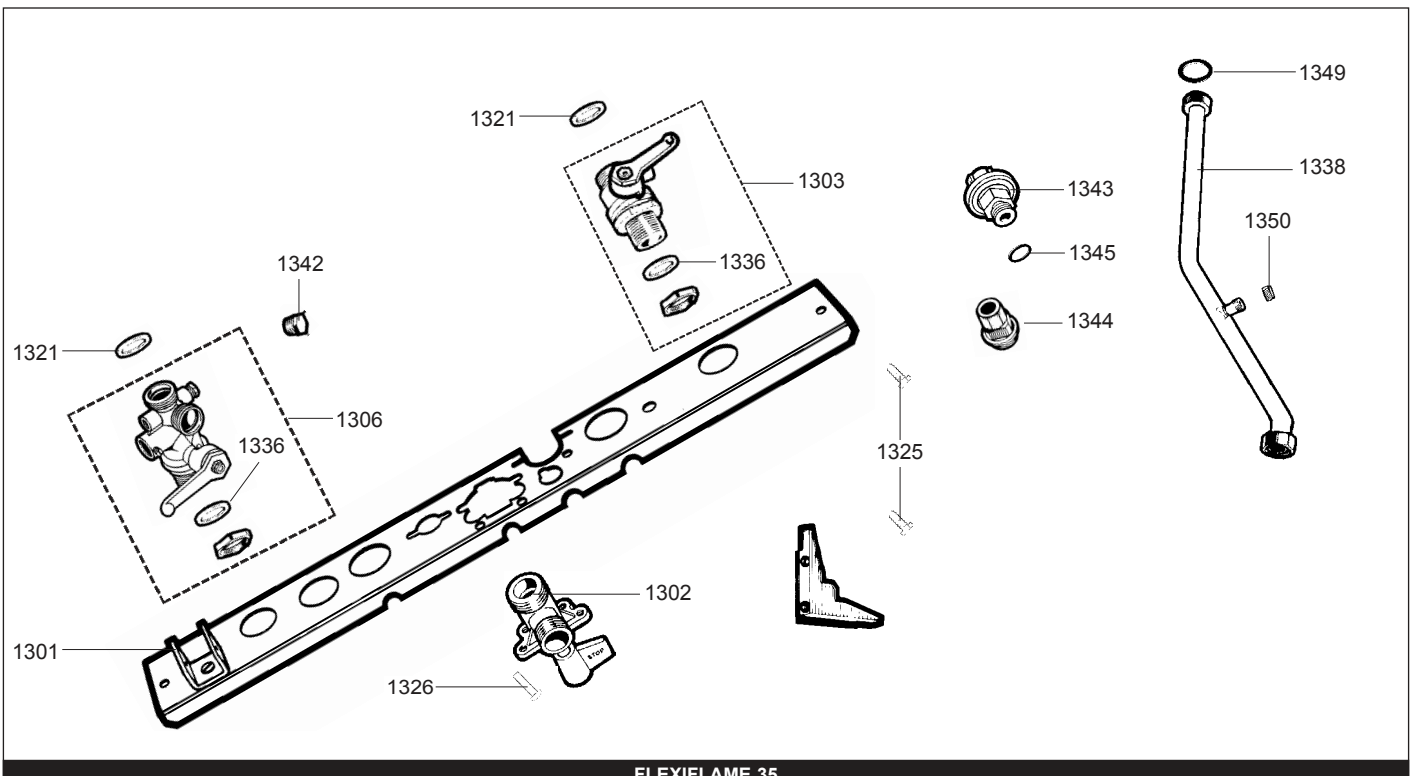

FLEXIFLAME 35

☉⇒	Description	Manf. Pt. N	Type	<div style="display: flex; justify-content: space-between; align-items: center;"> <div style="border: 1px solid black; padding: 2px; transform: rotate(-15deg); font-size: 8px;"> CELTIC 235 HP CELTIC 335 HP TIG 335 HP FLEXIFLAME 35 </div> <div style="border: 1px solid black; padding: 2px; font-size: 10px;">31</div> </div>																	
				1	2	3	4	5	6	7	8	9	10	11	12	13	14	15	16	17	18
1300	COCKS & COPPER PLATE																				
1302	GAS SERVICE TAP	60044500		•	•	•	•														
1303	WATER FLOW SERVICE TAP	60081583			•	•												12/95			
	WATER FLOW SERVICE TAP	60081583		•																	
	WATER FLOW SERVICE TAP	60081771				•	•										01/96				
	WATER FLOW SERVICE TAP KIT	60081788						•													
1306	WATER RETURN SERVICE TAP	60081579			•	•															
	WATER RETURN SERVICE TAP KIT	60081789						•													
	WATER RETURN SERVICE TAP KIT	60081561		•																	
1311	TAP HEAD ASSY	60067704		•		•															
1312	SHEET GASKET D: 29.6-25.5-1.5	60061856-04		•		•															
1313	HOT WATER TUBE	61009470		•																	
1314	DRAIN SCREW ASSY	60081028		•		•															
1316	TAP KNOB	60066107		•		•															
1317	COMPLETE WASHERS KIT	60081584		•	•	•															
1320	O-RING D: 11.1-1.78	60024183-38		•																	
1321	O-RING D: 16-1.9	60024183-37		•	•	•	•														
1325	TAPPING SCREW CBLX D: 6.3-13	61010648		•	•	•	•	•													
1326	SCREW M 6-10	60031527-03		•	•	•	•	•													
1336	SHEET GASKET D: 42-34-1.5	60061857-24		•	•	•	•														
1337	CLIP	60031546		•																	
1338	TUBE - C.O.V. TO HEATING BODY	61004813						•													
	HEATING FLOW TUBE	61004344		•																	
1342	PLUG M 10-100	60036342-08		•	•	•	•														
1343	PRESSURE SENSOR 0.8 B	61003495		•	•	•	•										01/96				
1344	CONNECTION	61003663		•	•	•	•										01/96				
1345	O-RING D: 6-1	60024164-41		•	•	•	•										01/96				
1346	TAP	60031721					•														
1349	O-RING D: 16.1-1.6	60024184-35						•													
1350	NUT M 14-0.75	60064552						•													

CELTIC & TIG 35 - FLEXIFLAME 35

Domestic Gas Boilers

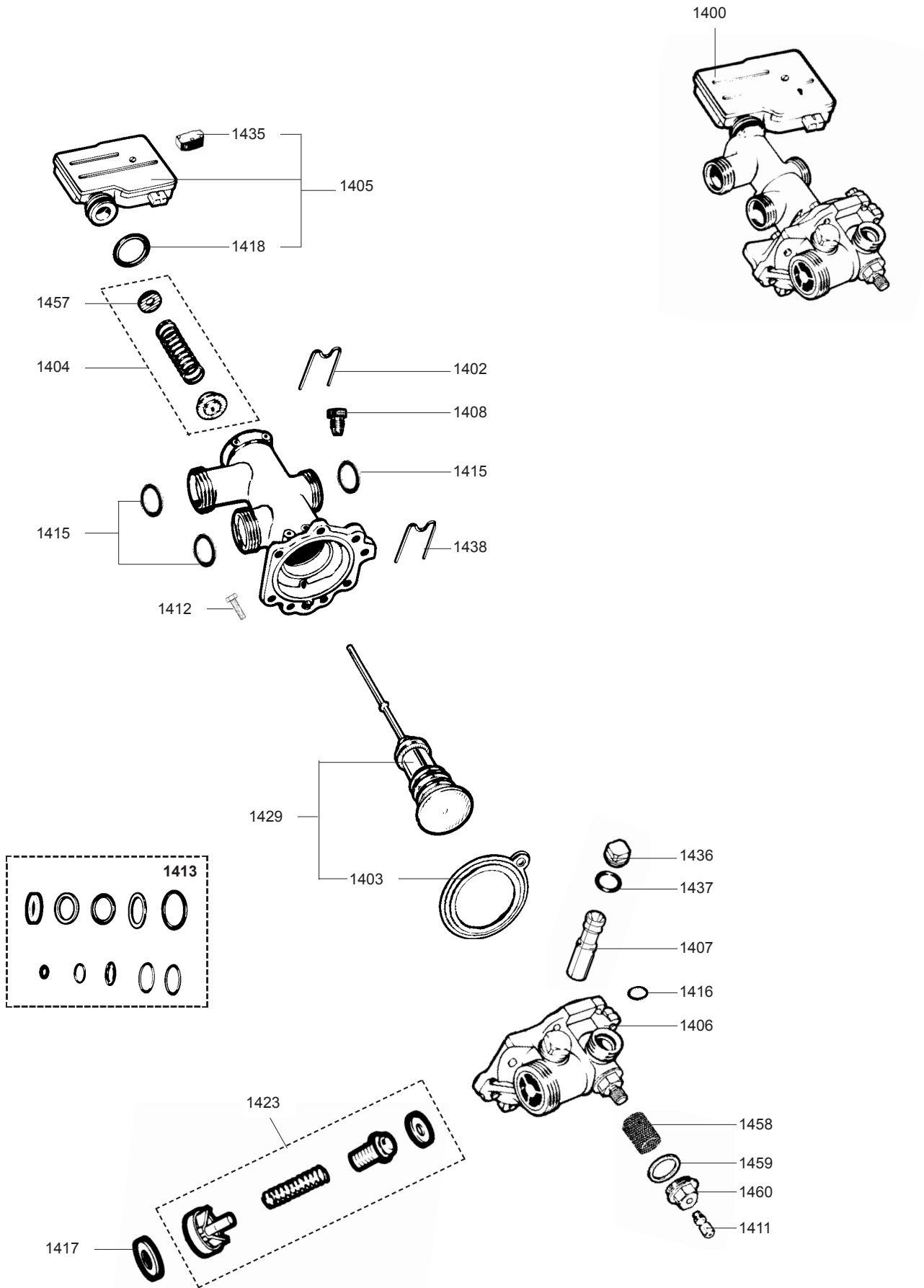

☉⇒	Description	Manf. Pt. N	Type	<div style="display: flex; justify-content: space-between; align-items: center;"> <div style="border: 1px solid black; padding: 2px;"> CELTIC 235 HP CELTIC 335 HP TIG 335 HP FLEXIFLAME 35 </div> <div style="border: 1px solid black; padding: 2px;">31</div> </div>																	
				1	2	3	4	5	6	7	8	9	10	11	12	13	14	15	16	17	18
1400	CHANGE OVER VALVE ASSY	60078088		•																	
1402	CLIP	60031764		•																	
1403	DIAPHRAGM	60081016		•																	
1404	VALVE SEAT KIT	60081017		•																	
1405	MICRO SWITCH BOX ASSY	60046713		•																	
1406	CHANGE OVER VALVE BASE	60078182		•																	
1407	VENTURI D: 1.95	60018892-40		•																	
1408	PLUG M 10-100	60036342-08		•																	
1411	DRAIN SCREW ASSY	60081028		•																	
1412	SCREW HX M 5-12	61010131		•																	
1413	GASKET KIT	60081279		•																	
1415	O-RING D: 16-1.9	60024183-37		•																	
1416	O-RING D: 11.1-1.78	60024183-38		•																	
1417	SHEET GASKET D: 29.6-22-1.5	60061856-14		•																	
1418	O-RING D: 19.8-3.6	60024164-24		•																	
1423	NON-RETURN VALVE KIT	60081027		•																	
1429	HEATING VALVE KIT	60081237		•																	
1435	SINGLE MICRO SWITCH	61001157		•																	
1436	PLUG 3/8»	60043784-08		•																	
1437	SHEET GASKET D: 20.1-17.1-1.5	60061855-09		•																	
1438	CLIP	60025076-03		•																	
1457	WASHER D: 16-6.2-0.5	60031280-01		•																	
1458	FILTER	61008934		•																	
1459	O-RING D: 22-2	60024959-03		•																	
1460	PLUG	61008933		•																	

1400

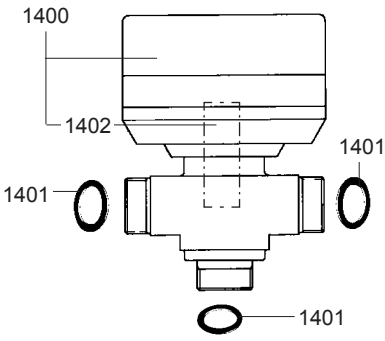

1500

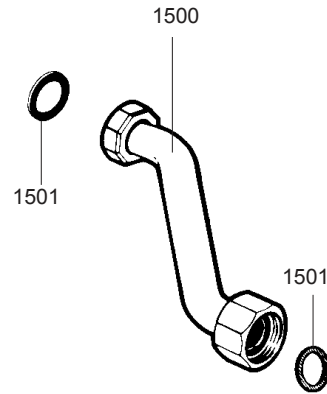

1600

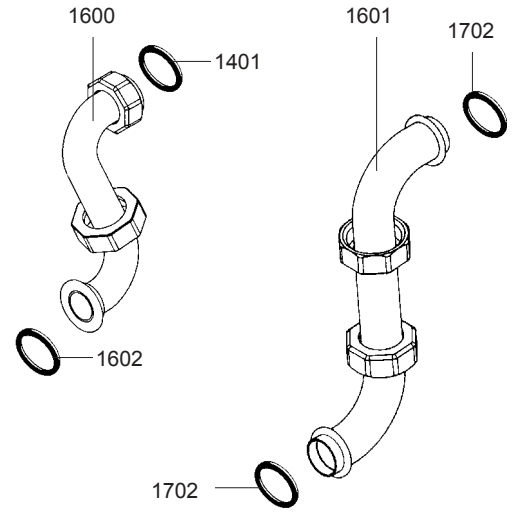

1700

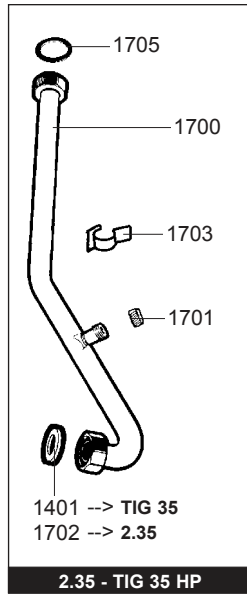
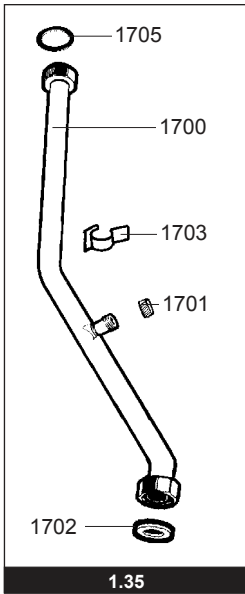

1800

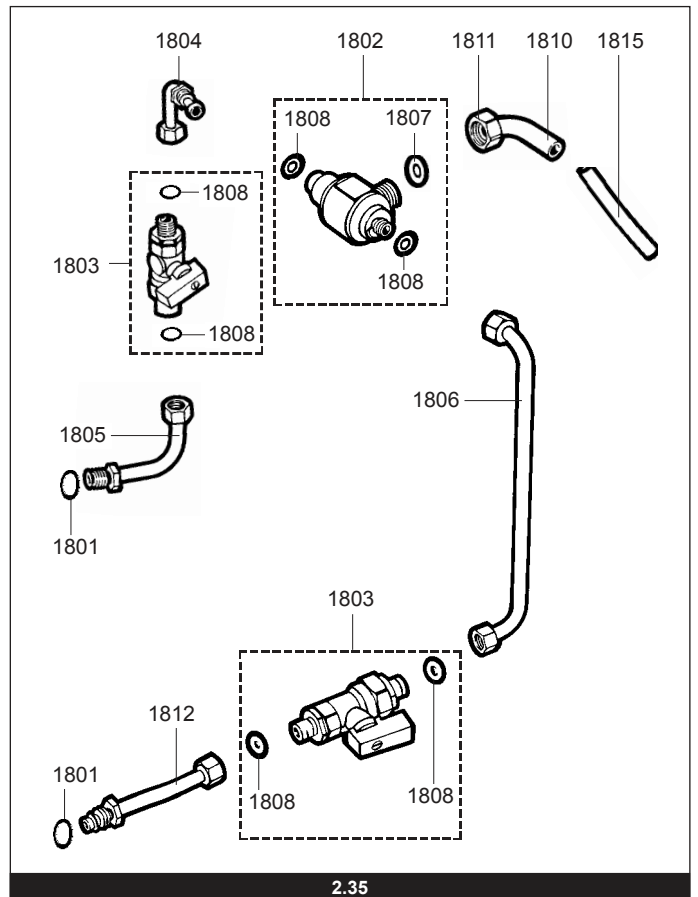

1900

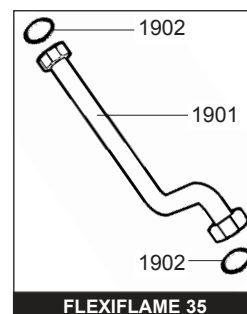
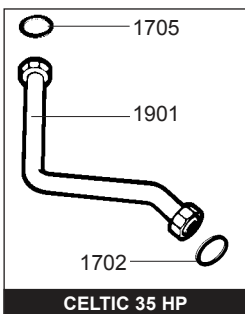

2000

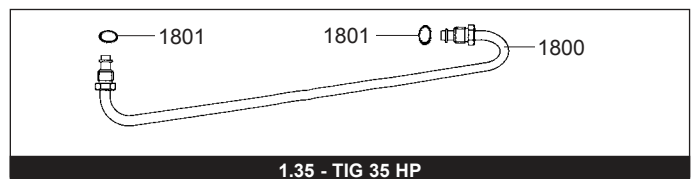
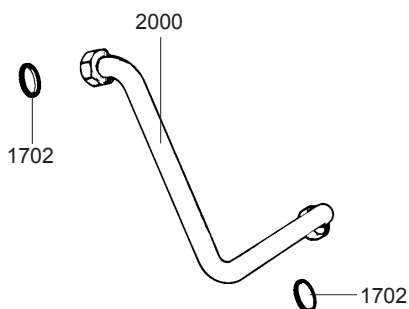

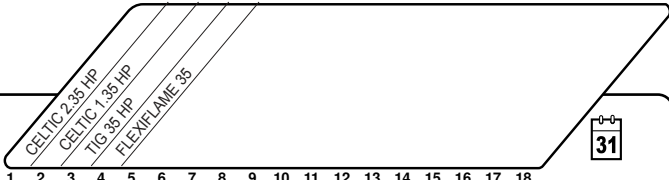
☉⇒	Description	Manf. Pt. N	Type																			31
				1	2	3	4	5	6	7	8	9	10	11	12	13	14	15	16	17	18	
1400	THREE-WAY VALVE	61008271					•															
1401	SHEET GASKET D: 24-16.2-1.5	60061855-02																				
1402	THREE-WAY VALVE REPAIR KIT	60081903					•															
1500	GAS TUBE	60074041			•	•	•	•														
1501	SHEET GASKET D: 24-18.2-1.5	60022835-01			•	•	•	•														
1600	COLD WATER TUBE C.O.V. TO EXC.	61009399			•																	
1601	HEATING TUBE	61009396			•																	
1602	SHEET GASKET D: 29.6-22-1.5	60061856-14			•																	
1700	TUBE - C.O.V. TO HEATING BODY	61004351			•																	
	TUBE - C.O.V. TO HEATING BODY	61004813				•																
	TUBE-HEAT. BODY TO 3 WAY VALVE	61008264					•															
1701	NUT M 14-0.75	60064552			•	•	•															
1702	O-RING D: 16-1.9	60024183-37			•	•	•															
1703	CLIP	60078502			•	•	•															
1705	O-RING D: 16.1-1.6	60024184-35			•	•	•															
1800	BYPASS TUBE	61004812				•	•															
1801	O-RING D: 6-1	60024164-41			•	•	•															
1802	DISCONNECTOR KIT	60081486			•																	
1803	DISCONNECTOR SERVICE TAP KIT	60081487			•																	
1804	DISCONNECTOR TUBE	61007264			•																	
1805	TUBE - C.O.V. TO TAP	61007126			•																	
1806	DISCONNECTOR TUBE	61007319			•																	
1807	SHEET GASKET D: 14.8-10.3-1.5	60061854-11			•																	
1808	SHEET GASKET D: 8.5-4.1-1.5	60061852-12			•																	
1810	CONNECTING PIPE	60001574			•																	
1811	NUT 3/8» THICK: 11	60020746-20			•																	
1812	TUBE - C.O.V. TO TAP	61007320			•																	
1815	TUBE PVC D: 9x12 L: 1M	60081266			•																	
1900	TUBE - PUMP TO HEAT EXCHANGER																					
1901	HEATING RETURN TUBE	61004352			•	•	•															
	HEATING RETURN TUBE	61014017										•									04/97	
	HEATING RETURN TUBE	61012306										•									05/96	
1902	SHEET GASKET D: 29.6-22-1.5	60061856-14										•									03/97	
2000	SHORT CIRCUIT TUBE	61009397			•																	

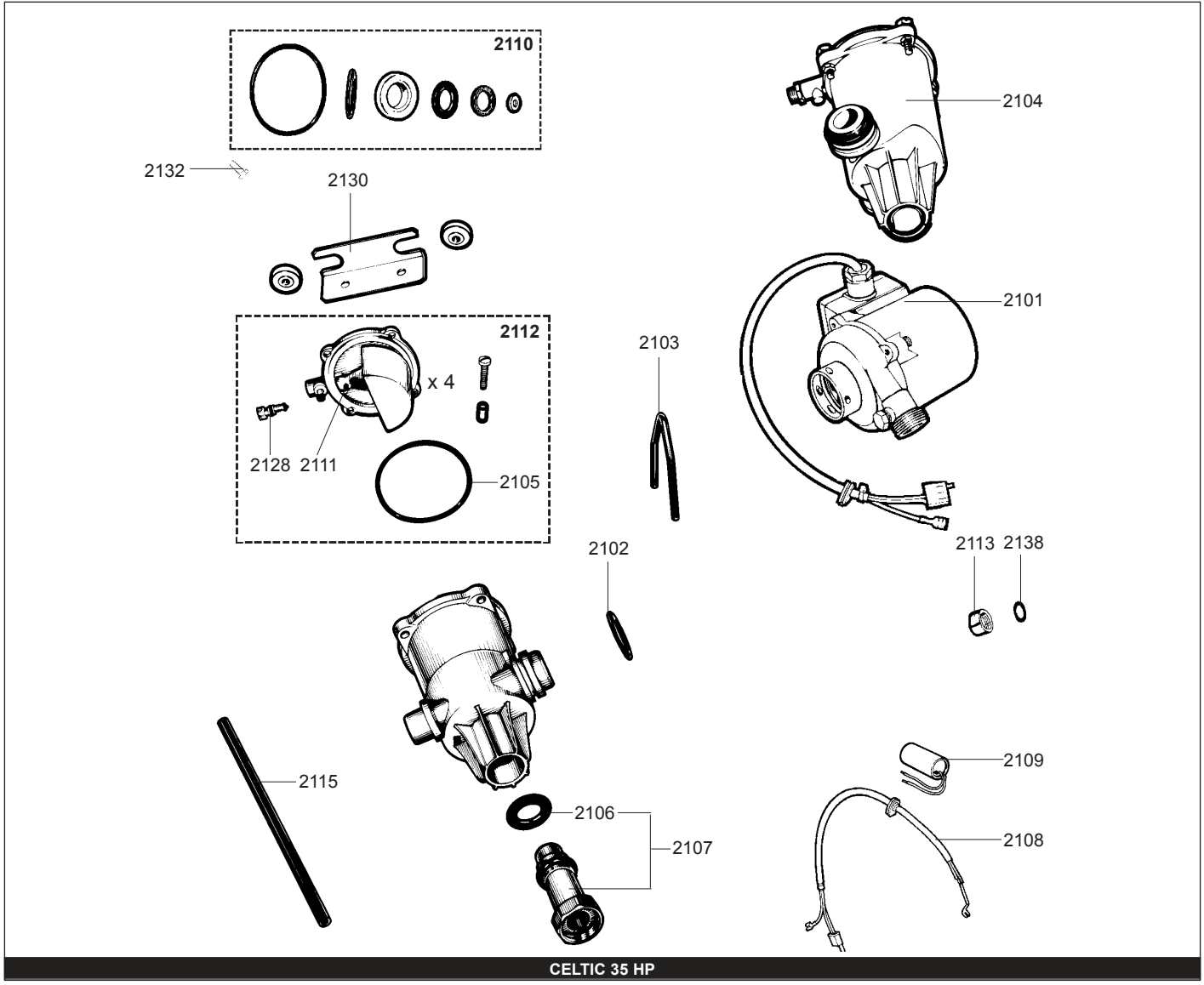

CELTIC 35 HP

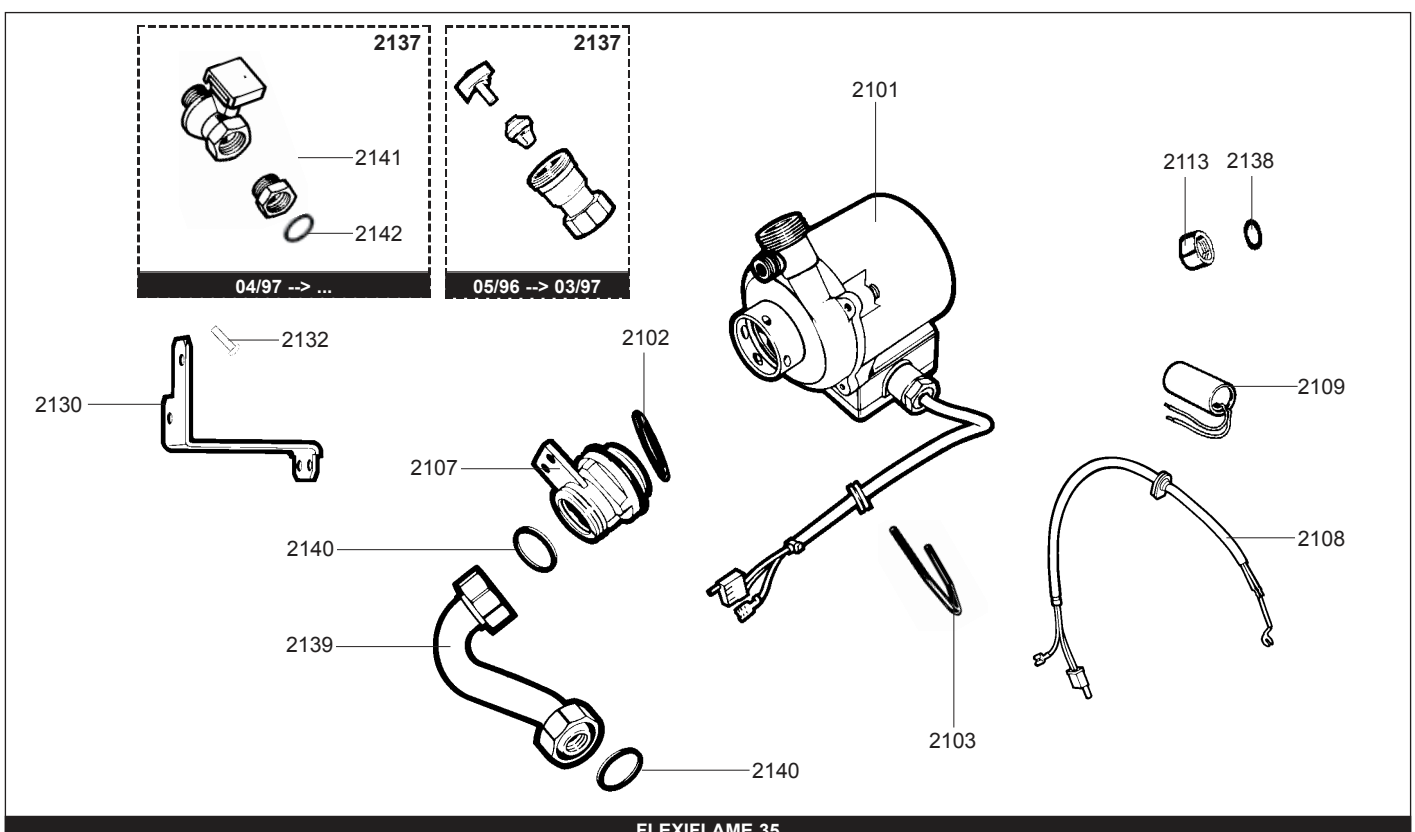

FLEXIFLAME 35

☉⇒	Description	Manf. Pt. N	Type	<div style="display: flex; justify-content: space-between; align-items: center;"> <div style="writing-mode: vertical-rl; transform: rotate(180deg); font-size: small;"> CELTIC 2.35 HP CELTIC 1.35 HP TIG 35 HP FLEXIFLAME 35 </div> <div style="border: 1px solid black; padding: 2px;">31</div> </div>																		1	2	3	4	5	6	7	8	9	10	11	12	13	14	15	16	17	18		
2100	PUMP																																								
2101	PUMP UP 15/50 230V	61010612					•																																		
	PUMP UP 15/60 220V	61010613		•	•	•																																			
2102	O-RING D: 27.8-3.6	60024164-35		•	•	•	•																																		
2103	CLIP	60030898-03		•	•	•	•																																		
2104	AIR SEPARATOR	60037374		•	•	•																																			
2105	GASKET (/Air separator)	60053847		•	•	•																																			
2106	O-RING D: 16-5	60024959-12		•	•	•																																			
2107	CONNECTION	60049355-08					•																																		
	AIR SEPARATOR CONNECTION KIT	60081563		•	•	•																																			
2108	PUMP LEAD (1 SPEED)	60045641		•	•	•																																			
	PUMP LEAD (2 SPEEDS)	61004115					•																																		
2109	CAPACITOR	61000652-10		•	•	•	•																																		
2110	GASKET KIT	60081024		•	•	•																																			
2111	AIR SEPARATOR VALVE	60035750		•	•	•																																			
2112	AIR SEPARATOR COVER KIT	60035748		•	•	•																																			
2113	PLUG M 10-100	60015709		•	•	•	•																																		
2115	TUBE PVC D: 9 L: 315	60030900		•	•	•																																			
2128	DRAIN SCREW ASSY	60081421		•	•	•																																			
2130	PUMP SUPPORT	60058324					•																																		
2132	TAPPING SCREW CBLX D: 6.3-13	61010648		•	•	•																																			
2137	NON-RETURN VALVE	60054448					•															05/96	03/97																		
	STOPPED WATER THROTTLE KIT	60081798					•															04/97																			
2138	WASHER D: 8.8-3.25	60054118		•	•	•	•																																		
2139	HEATING RETURN TUBE	61012307					•																																		
2140	O-RING D: 16-1.9	60024183-37					•																																		
2141	SHEET GASKET D: 29.6-22-1.5	60061856-14					•															04/97																			
2142	SHEET GASKET D: 24-16.2-1.5	60061855-02					•																																		

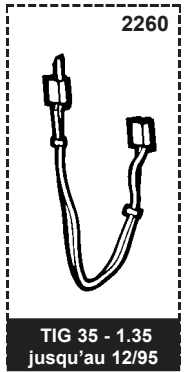
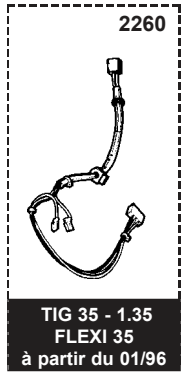
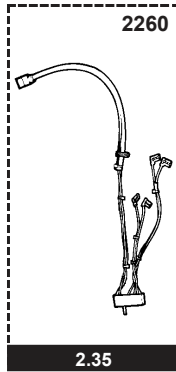
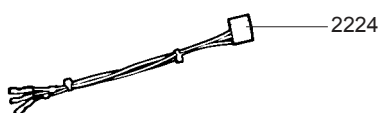
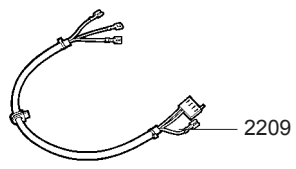
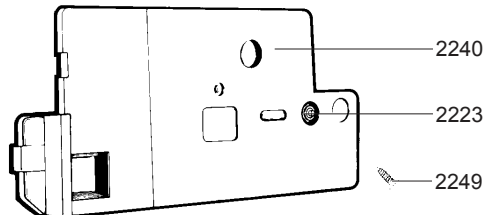
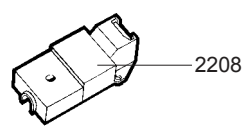
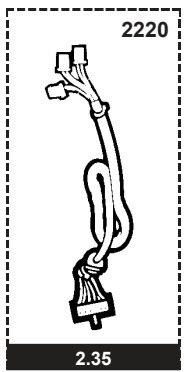
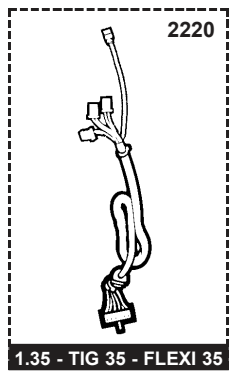
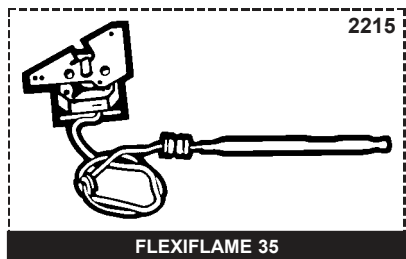
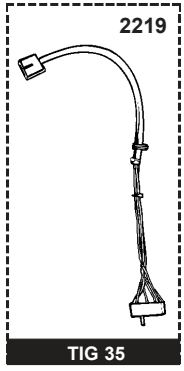
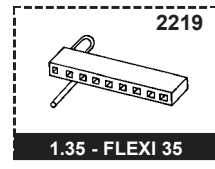
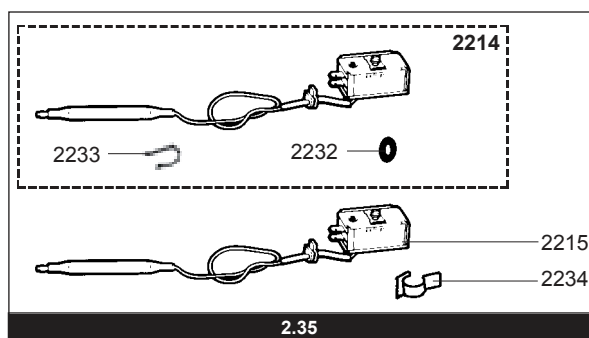
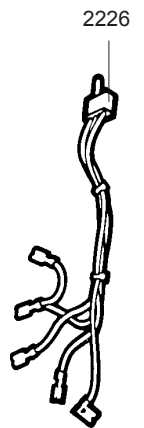
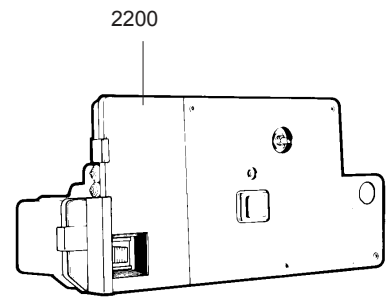
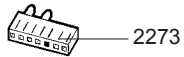
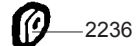
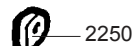
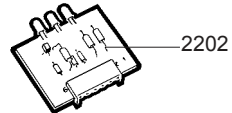
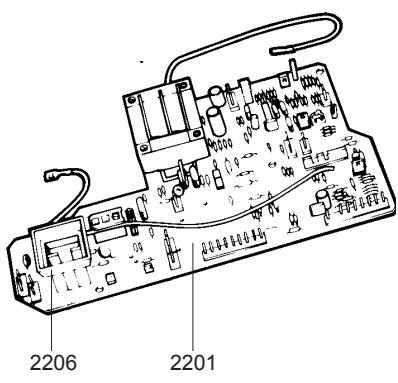
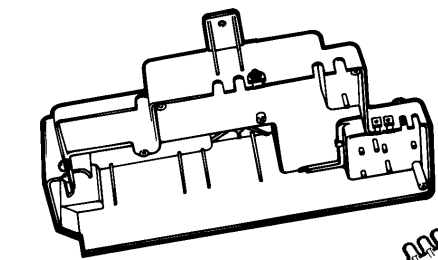
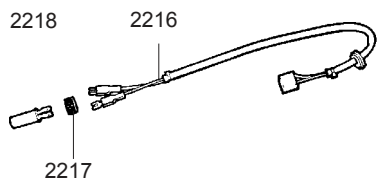
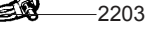
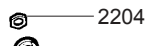
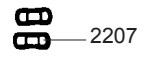
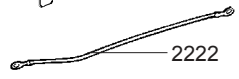
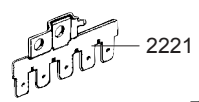
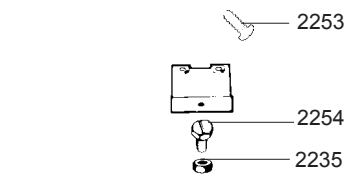

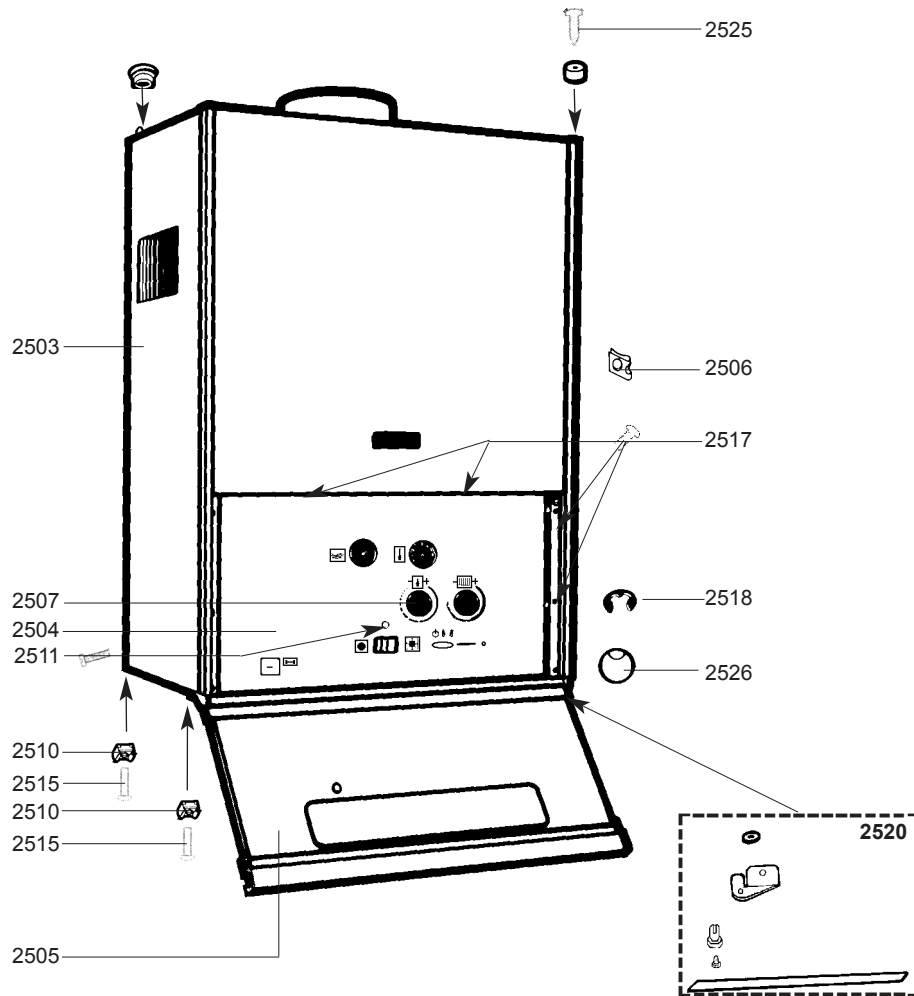
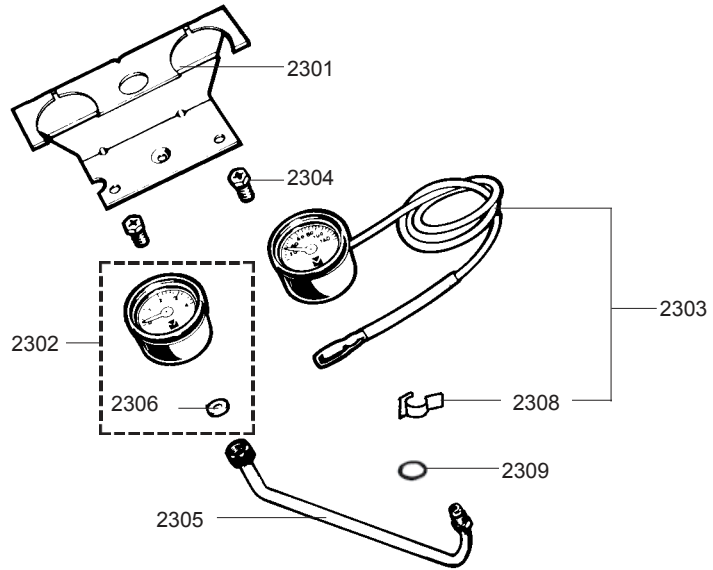

☉➔	Description	Manf. Pt. N	Type	<div style="display: flex; justify-content: space-between; align-items: center;"> <div style="transform: rotate(-45deg); font-size: small;"> CELTIC 235 HP CELTIC 335 HP TIG 335 HP FLEXIFLAME 35 </div> <div style="border: 1px solid black; padding: 2px;">31</div> </div>																	
				1	2	3	4	5	6	7	8	9	10	11	12	13	14	15	16	17	18
2300	PRESSURE TEMP GAUGE																				
2301	SUPPORT BRACKET	60078362		•	•	•	•														
2302	PRESSURE GAUGE ASSY	60081180		•	•	•	•														
2303	THERMOMETER ASSY	60081022		•	•	•	•														
2304	TAPPING SCREW CBLX D: 6.3-13	61010648		•	•	•	•														
2305	PRESSURE GAUGE TUBE	61004449		•	•	•															
2306	SHEET GASKET D: 8.5-4.1-1.5	60061852-12		•	•	•	•														
2308	CLIP	60078502		•	•	•	•														
2309	O-RING D: 6-1	60024164-41		•	•	•	•														
2500	FRONT CASE																				
2503	LEFT SIDE PANEL	60044201		•	•	•	•														
2504	CONTROL PANEL	61009940			•																
	CONTROL PANEL	61003258		•																	
2505	DOOR ASSY	61008272		•	•	•	•														
2506	SPIRE CLIP	60063603		•	•	•	•														
2507	BLACK POTENTIOMETER KNOB	60078181		•	•	•	•														
2510	TRAPPED NUT M 6	60004806-03		•	•	•	•														
2511	SCREW CLS M 6-14	60014044		•	•	•	•														
2515	SCREW M 6-10	60031527-03		•	•	•	•														
2517	TAPPING SCREW CBLX D: 4.2-9.5	61010125		•	•	•	•														
2518	CLIP	60078784		•	•	•	•														
2520	HINGE REPAIR KIT	60081411		•	•	•	•														
2525	TAPPING SCREW CBLZ D: 3.9-9.5	60050460-03					•														
2526	BLACK AQUASTAT KNOB	61004996					•														

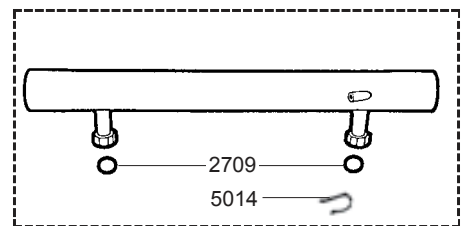
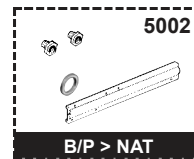
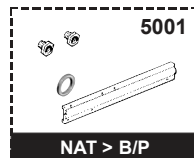
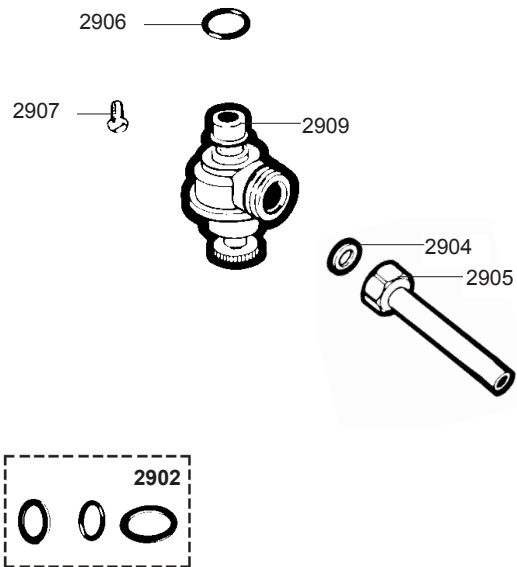
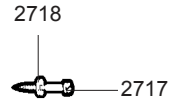
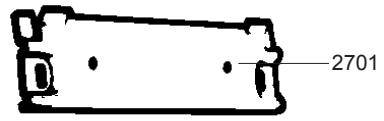
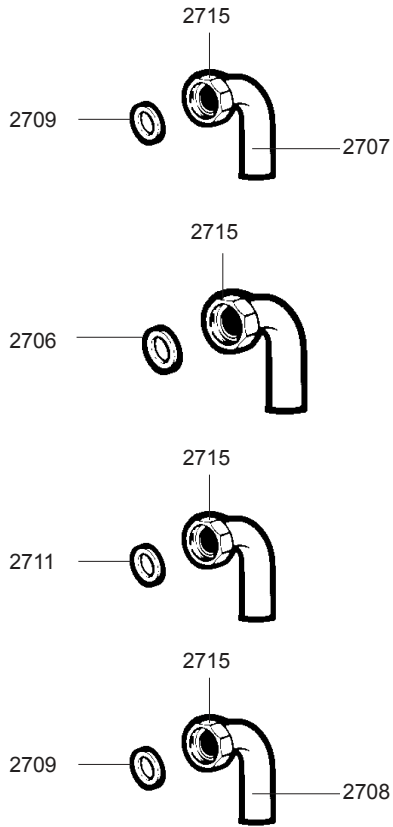

☉⇒	Description	Manf. Pt. N	Type	<div style="display: flex; justify-content: space-between; align-items: center;"> <div style="border: 1px solid black; padding: 2px; transform: rotate(-45deg); font-size: 8px;"> CELTIC 235 HP CELTIC 135 HP TIG 35 HP FLEXIFLAME 35 </div> <div style="border: 1px solid black; padding: 2px; font-size: 10px;">31</div> </div>																	
				1	2	3	4	5	6	7	8	9	10	11	12	13	14	15	16	17	18
2700	JIG PLATE & PIPE FITTING																				
2701	WALL MOUNTING BRACKET	60025182		•	•	•	•														
2706	SHEET GASKET D: 24-16.2-1.5	60061855-02				•															
2707	CONNECTING PIPE	60055675		•																	
2708	CONNECTING PIPE HOT WATER	60055674		•																	
2709	SHEET GASKET D: 24-18.2-1.5	60061855-01		•																	
2711	SHEET GASKET D: 24-18.2-1.5	60022835-01		•	•	•	•														
2715	NUT 3/4»	60020748-68		•	•	•	•														
2717	WOOD SCREW	60025617-03		•	•	•	•														
2718	WASHER D: 14.2-7.2-1.2	60005369-03		•	•	•	•														
2900	PRESSURE RELIEF VALVE																				
2902	VALVE WASHER KIT	60081025		•	•	•															
2904	WASHER D: 18.4-12.2-1.5	60061855-14		•	•	•															
2905	NUT 1/2» THICK: 10	60020747-68		•	•	•															
2906	O-RING D: 13.6-2.7	60024164-18		•	•	•															
2907	GRUB SCREW	60017908		•	•	•															
2909	PRESSURE RELIEF VALVE	61020933				•	•											12/95			
	PRESSURE RELIEF VALVE	61020933		•	•	•															
5000	ACCESSORIES																				
5001	CONVERSION KIT NAT > LPG	61011383		•	•	•	•											01/96			
	CONVERSION KIT NAT > LPG	61004960				•	•											12/95			
5002	CONVERSION KIT LPG > NAT	61012308		•	•	•	•											01/96			
5014	CLIP	60074039					•														

LIST OF THE ABBREVIATIONS

HW	: Hot water.
CW	: Cold water.
C	: Ceramic resistance (normal heating).
Ca	: Ceramic resistance (accelerated heating)
TP	: Immersion heater.
1F	: With fittings.
2F	: Without fittings.
3F	: With fittings and another outlet connection.
AMI	: With mixing valve.
SMI	: Without mixing valve.
PUISS	: Power of th appliance.
PN	: Appliance with normal pression.
LP	: Appliance with low pression.
PV	: Appliance with variable power.
PF	: Appliance with fixed power.

IDENTIFICATION PLATE

SERIAL NUMBER

10 Characters :	04 05 125 011	Sequential number Manufacturing day Year of manufacture
11 Characters :	1 95 065004 - 31	Technical number of the appliance Sequential number Year of manufacture
Month of manufacture : from 1 to 9 → Jan. to Sep., O → Oct., N → Nov., D → Dec.		
19 Characters :	08 05 0013199 900640031	Product reference Sequential number
Year of manufacture Month of manufacture		
20 Characters :	3675007 XX 2 07 070 00315	Sequential number Manufacturing day Year of manufacture
Product reference Millenium of manufacture		
21 Characters :	3675007 XX 07 070 0000315	Sequential number Manufacturing day
Product reference Year of manufacture		

The indications mentioned on the prices, commercial or technical literature and the scheme are written for your guidance and are available at a given time. The CONSTRUCTOR retains the power to modify the presentation, the form, the size, the conception or the material of the products.