



SPARE PARTS EXPLODED VIEW
GAS-WALL CONDENSING BOILERS
Model
ALTEAS ONE NET FR

R8218594-02 - 18/03/2021

ALTEAS ONE NET FR

Gas-wall condensing boilers

1	3301615	ALTEAS ONE NET 30 FR	10-2020	-
Col	Reference	Model type	Begin	End

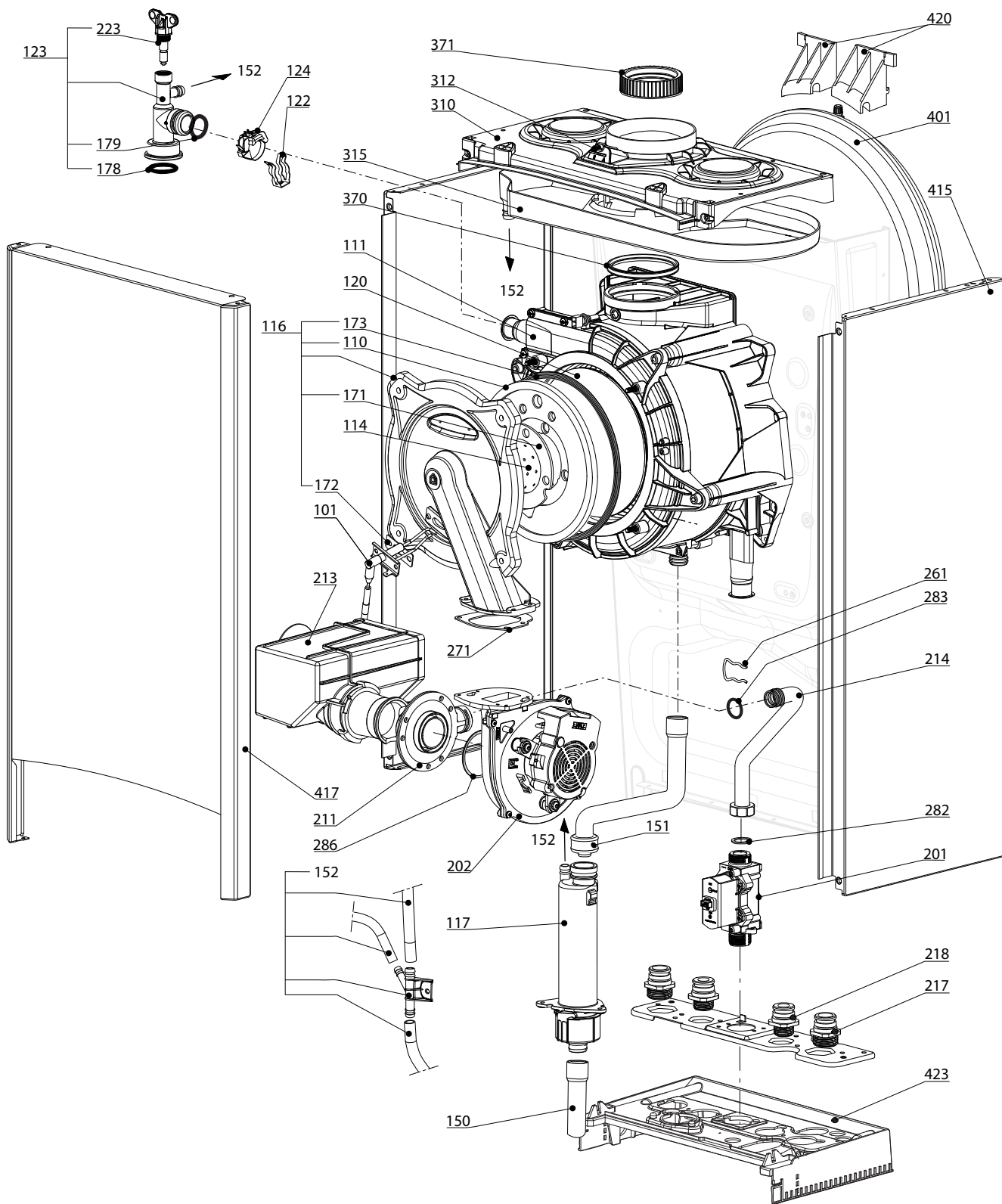

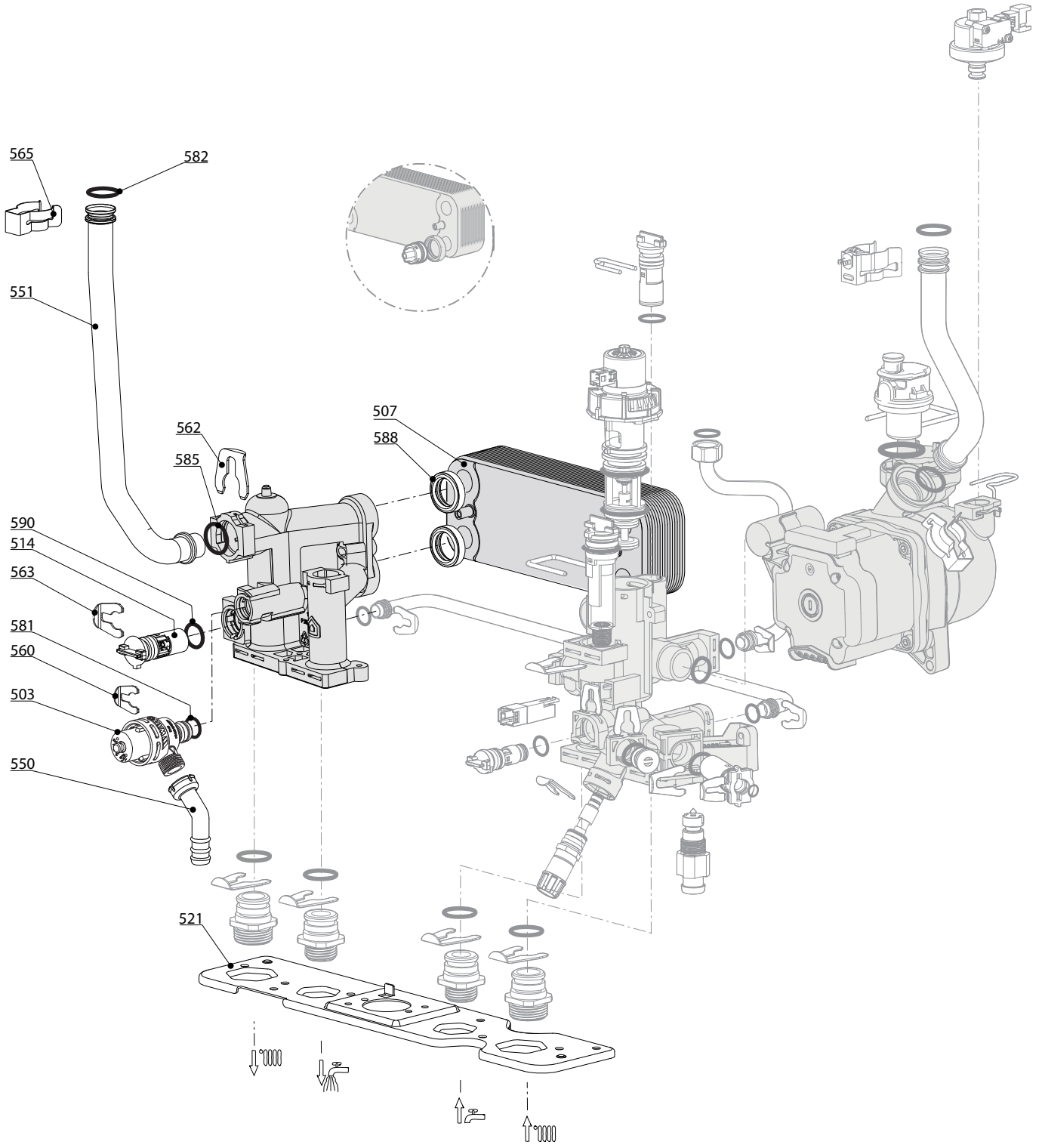

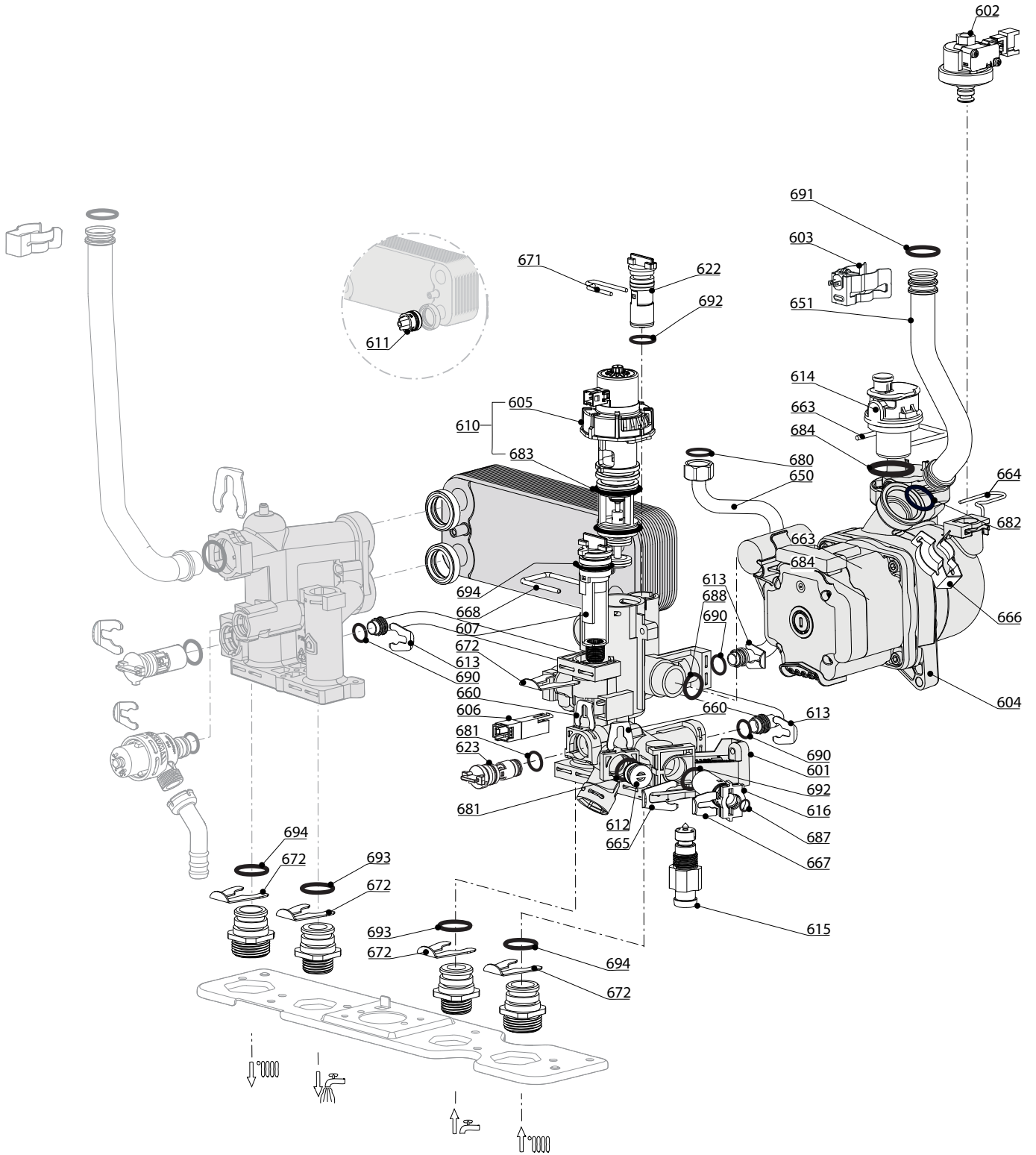

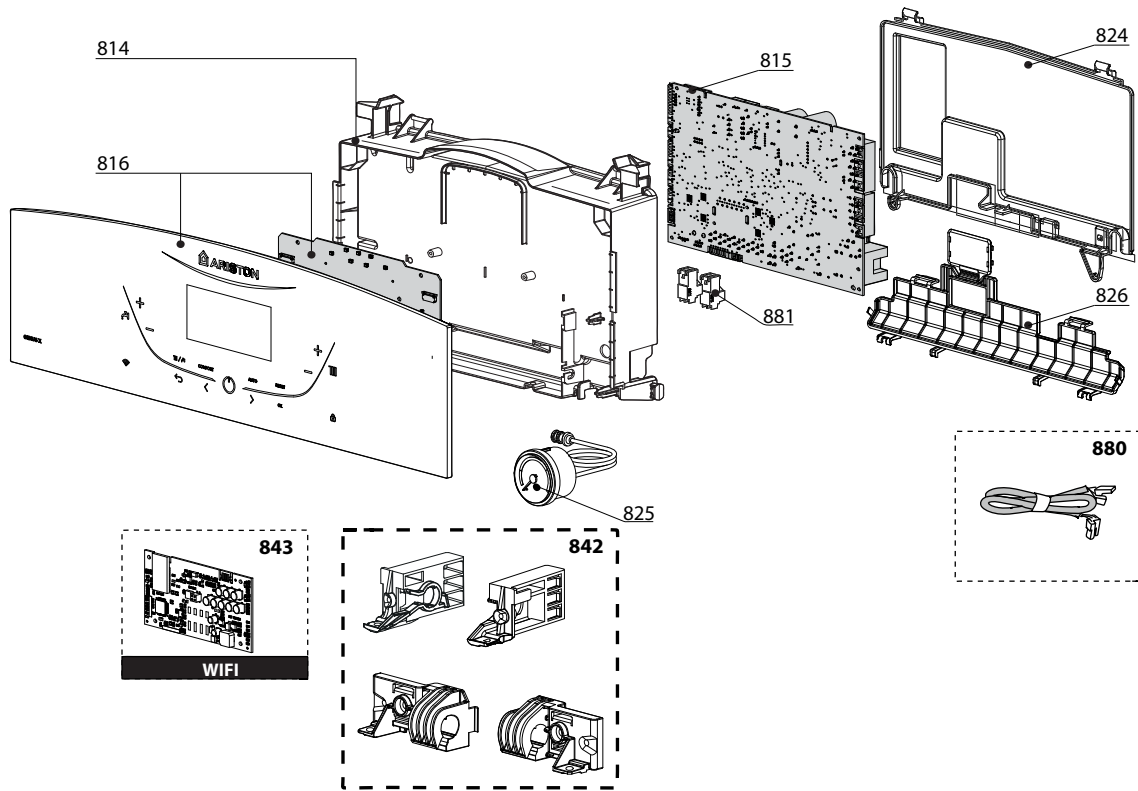

5000

- 5020**
- Accessories
 - Options
 - Opzioni
 - Accessorio
 - Zubehör
 - Opties

LIST OF THE ABBREVIATIONS

HW	: Hot water.
CW	: Cold water.
C	: Ceramic resistance (normal heating).
Ca	: Ceramic resistance (accelerated heating)
TP	: Immersion heater.
1F	: With fittings.
2F	: Without fittings.
3F	: With fittings and another outlet connection.
AMI	: With mixing valve.
SMI	: Without mixing valve.
PUISS	: Power of th appliance.
PN	: Appliance with normal pression.
LP	: Appliance with low pression.
PV	: Appliance with variable power.
PF	: Appliance with fixed power.

IDENTIFICATION PLATE

SERIAL NUMBER

10 Characters :	04 05 125 011	
		Sequential number
		Manufacturing day
		Year of manufacture
11 Characters :	1 95 065004 - 31	
Month of manufacture :		Technical number of the appliance
from 1 to 9 → Jan. to Sep.,		Sequential number
O → Oct., N → Nov.,		Year of manufacture
D → Dec.		
19 Characters :	08 05 0013199 900640031	
Year of manufacture		Product reference
Month of manufacture		Sequential number
20 Characters :	3675007 XX 2 07 070 00315	
Product reference		Sequential number
Millenium of manufacture		Manufacturing day
		Year of manufacture
21 Characters :	3675007 XX 07 070 0000315	
Product reference		Sequential number
Year of manufacture		Manufacturing day