

BMV 1-2 (2013->)

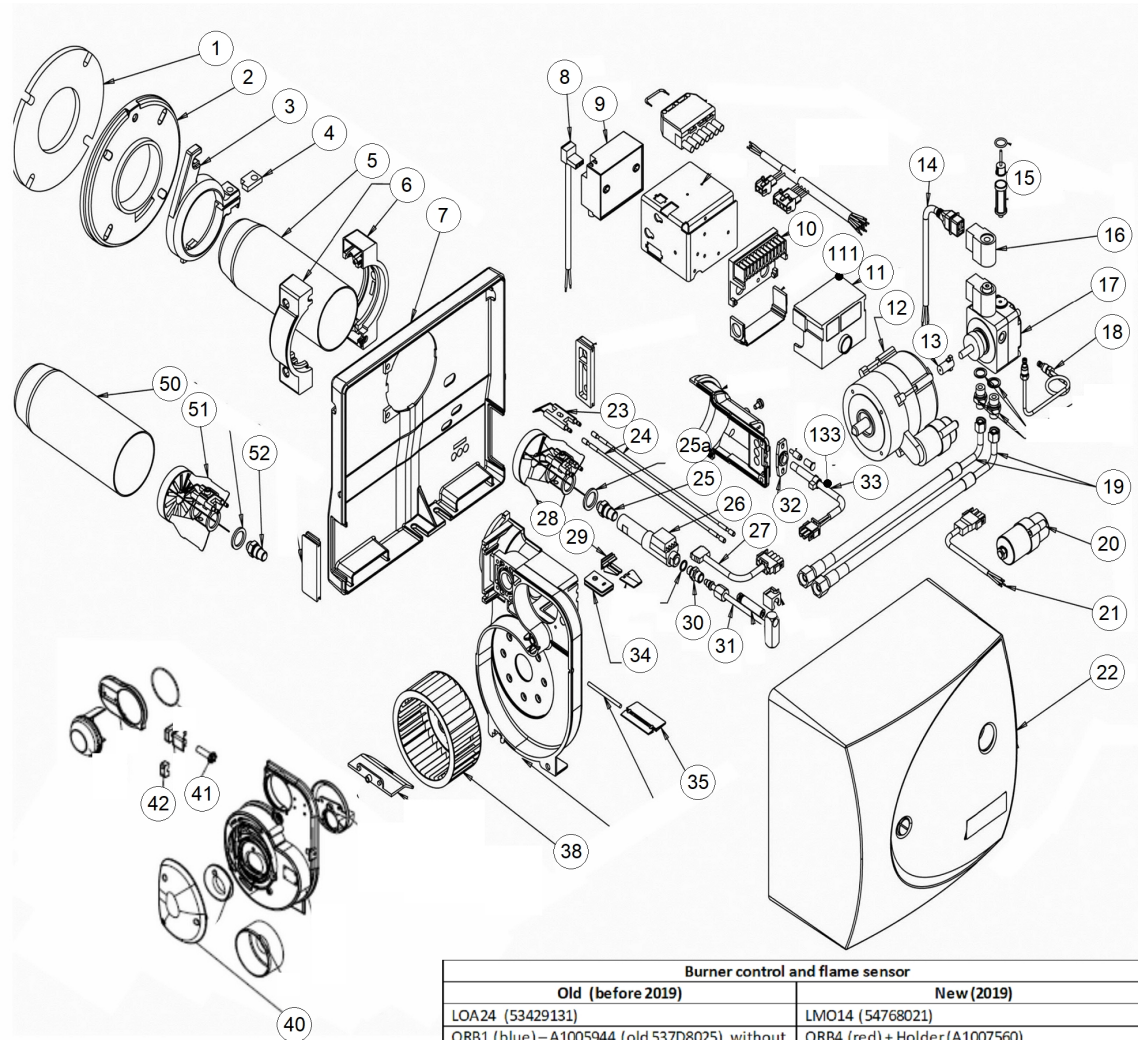

Burner control and flame sensor	
Old (before 2019)	New (2019)
LOA24 (53429131)	LMO14 (54768021)
QRB1 (blue) – A1005944 (old 537D8025) without holder	QRB4 (red) + Holder (A1007560)
QRB4 (red) not compatible with LOA	QRB1 compatible Older version compatible (with specific holder)















BMV 1-2 (2013->)

Code	Code GA	Quant.	Photo	Description	De --- A ---	Remarque
1	55429159	785279	1	Joint bride ronde BMV & BMR22-32-52		not 557A0091
2	537D8147	786403	1	Plaque de collerette BMV		
3	A1002667	787015	1	Clame fix.brûleur BMV 2012->	01-01-13-	Prev: 537D8143
4	537D8144	786401	1	Joint d'étanchéité collerette BMV		
5	537D8096	786388	1	Tube de combustion BMV1 (E)		
6	537D8150	786405	1	Flasque bipartie BMV		
7	A1002710	787021	1	Plaque de base BMV1-2 2012-> (-98)	01-01-13-	
8	537D5013	786175	1	Câble transfo allumage		
9	53429151	785075	1	Transfo allumage EBI 052F0030	01-01-12-	prev: 537D8098
10	537D8035	786376	1	Socle enfichable BMV		
11	53429131	785064	1	Coffret de sécurité LOA 24 brûleur		
111	54768021	785253	1	Automate brûleur BMR31-33-BMe1	11-02-20-	LMO14.11CHA
12	537D8186	786416	1	Moteur 90W BMV (V13) avec condensateur		
13	537D8081	786381	1	Accouplement moteur-pompe BMV		
133	A1007560	780396	1	Cellule BMV1-5 (10011.00105)		Only for LMO burner control
14	537D5010	786173	1	Câble électro-aimant		
15	537D8024	786367	1	Cartouche filtrante pour pompe		
16	A1005310	787441	1	Bobine électrovanne BMV T85	01-05-18-	prev: 537d8030
17	537D8033	786375	1	Pompe BMV1 (Danfoss BFP21 L3 R) +bobine		not 53429048
18	537D8032	786374	1	Conduite de pression de fioul		





BMV 1-2 (2013->)

Code	Code GA	Quant.	Photo	Description	De --- A ---	Remarque
19	537D8082	786382	2	 Flexible fioul 1100 mm		
20	537D8028	786371	1	 Condensateur (moteur BMV) 3µF		
21	537D5011		1			
				Câble de connexion du moteur		
22	537D8093	786387	1			
				Capot noir brûleur BMV		
23	537DZ024	786450	1	 Bloc d'électrodes BMV		
24	537D5014	786176	2	 Câble allumage BMV		
25	537D1028	786077	1			Default, for Delta Pro
				Gicleur Danfoss 0.60 Gus 45°H		
25a	537D1026	786075	1	 Gicleur Danfoss 0.75 Gus 60°H		
26	53429132	785065	1	 Préchauffeur (seul) FPHB 5 (->FPHE 5)		Prev: 537D8034
27	537D5012	786174	1	 Câble et prise mâle du prechauffeur		
28	537D9000	786423	1	 Accroche flamme BMV1-3-4 (4 fentes)		
30	537D8149		1			
				Raccord préchauffeur BMV		
31	537D1036	786083	1	 Tube porte-gicleur BMV1-2 (223,5mm)		
32	537D8145	786402	1			
				Cadre pour cellule BMV		
33	A1005944	910421	1		11-02-20-	Prev : 537D8025
				Cellule BMV1-5 (10011.00105)		
34	5476A030	786476	1	 Passe-fil câble allumage BMV		
35	537D8084	786384	1			
				Clapet d'air BMV		
38	537D8026	786369	1	 Roue ventil.BMV		
40	537D8184		1	 Cache entrée d'air BMV	01-07-12-	
41	A1002666		1			
				Axe commande réglage d'air BMV		



BMV 1-2 (2013->)

Code	Code GA	Quant.	Photo	Description	De --- A ---	Remarque
42	537D8116	910438	1		Clame noire réglage d'air BMV	
50	537D8097	786389	1		Tube de combustion BMV2 (F)	
51	537D9001	786424	1		Accroche flamme BMV2-5 (12 fentes)	
52	537D1027	786076	1		Gicleur Danfoss 1.25 Gus 60°H	
99	537D8159	786412	1		Réduction 80/50 BMV1 FV	For FV