

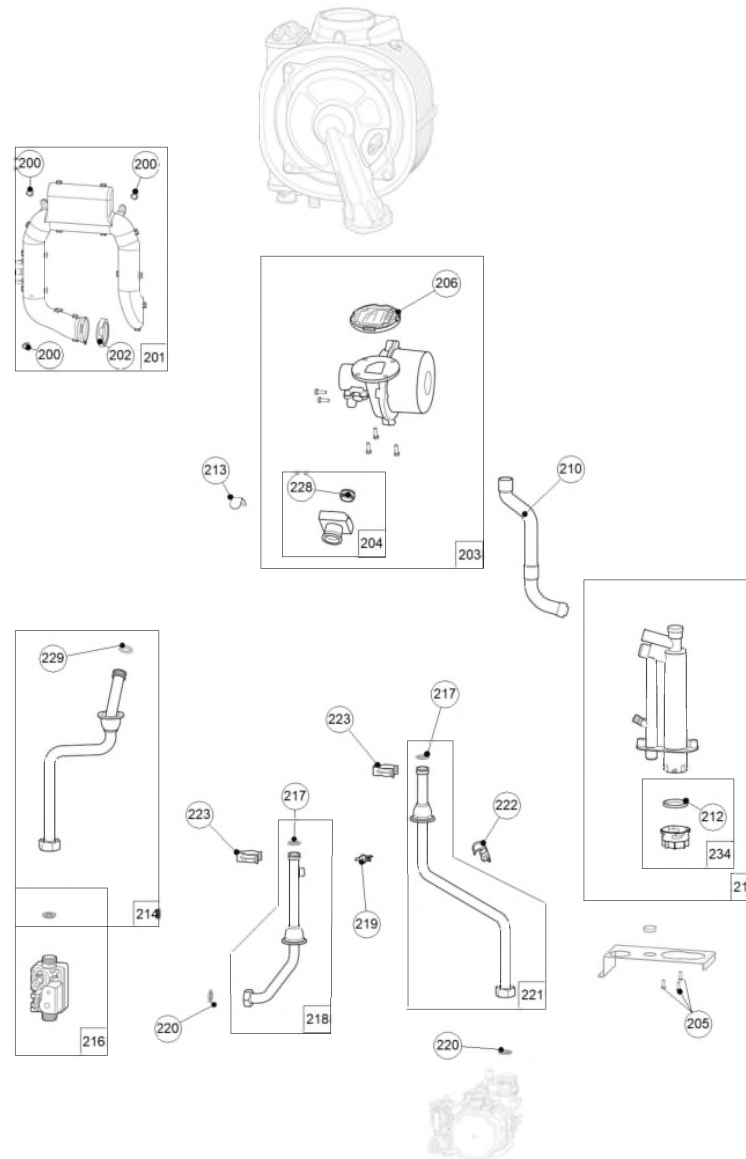













Boiler







Boiler

Code	Code GA	Quant.	Photo	Description	De --- A ---	Remarque	
75	182585	182585	1		Coude (gaz) - Bocht (gas) - Winkelstück (Gas)	15-02-22-	
86	142442		5		Joint 3/4-20/27	15-02-22-	"3/4""
200	122208		3		Écrou pour silencieux	15-02-22-	
201	105020		1		Silencieux	15-02-22-	
202	142289		1		Joint silencieux	15-02-22-	
203	988533		1		Ventilateur joints et adaptateur 35	15-02-22-	35kw
204	900328		1		Adaptateur venturi + joint	15-02-22-	
205	190045		4		Vis tôle	15-02-22-	TX20
206	142291		1		Joint clapet	15-02-22-	
210	182565		1		Tube évacuation	15-02-22-	
211	976009		1		Siphon	15-02-22-	
212	142203		1		Joint siphon	15-02-22-	
213	100187		2		Agrafe D18	15-02-22-	D18
214	982441		1		Tube gaz + joints	15-02-22-	
216	988118	988118	1		Vanne gaz + joint	15-02-22-	
217	142716		2		Joint 18x2,8	15-02-22-	ø int. 18x2,8
218	982436		1		Tube départ + joint	15-02-22-	
219	198758		1		Sonde chaudière QAK	15-02-22-	QAK 36.095/109
220	142442		5		Joint 3/4-20/27	15-02-22-	3/4 - 20/27
221	982437		1		Tube retour + joint	15-02-22-	



Boiler





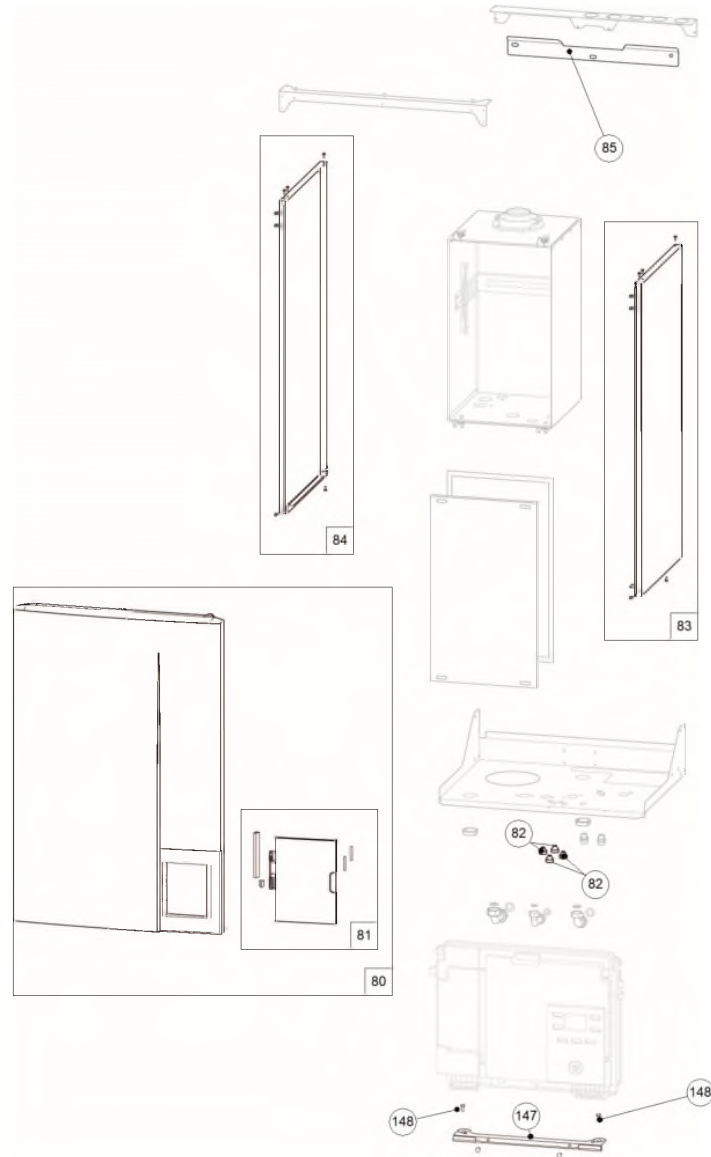

Code	Code GA	Quant.	Photo	Description	De --- A ---	Remarque
222	198757	1		Sonde retour D18-20	15-02-22-	D.18-20
223	110354	2		Clip	15-02-22-	
228	142292	1		Joint venturi	15-02-22-	
229	142795	1		Joint torique 7,04x3,53 Ilea	15-02-22-	17,04x3,53
234	943051	1		Bouchon + joint siphon / Stop + dichting sifon / Stopfen + Siphondichtung	15-02-22-	

Casing











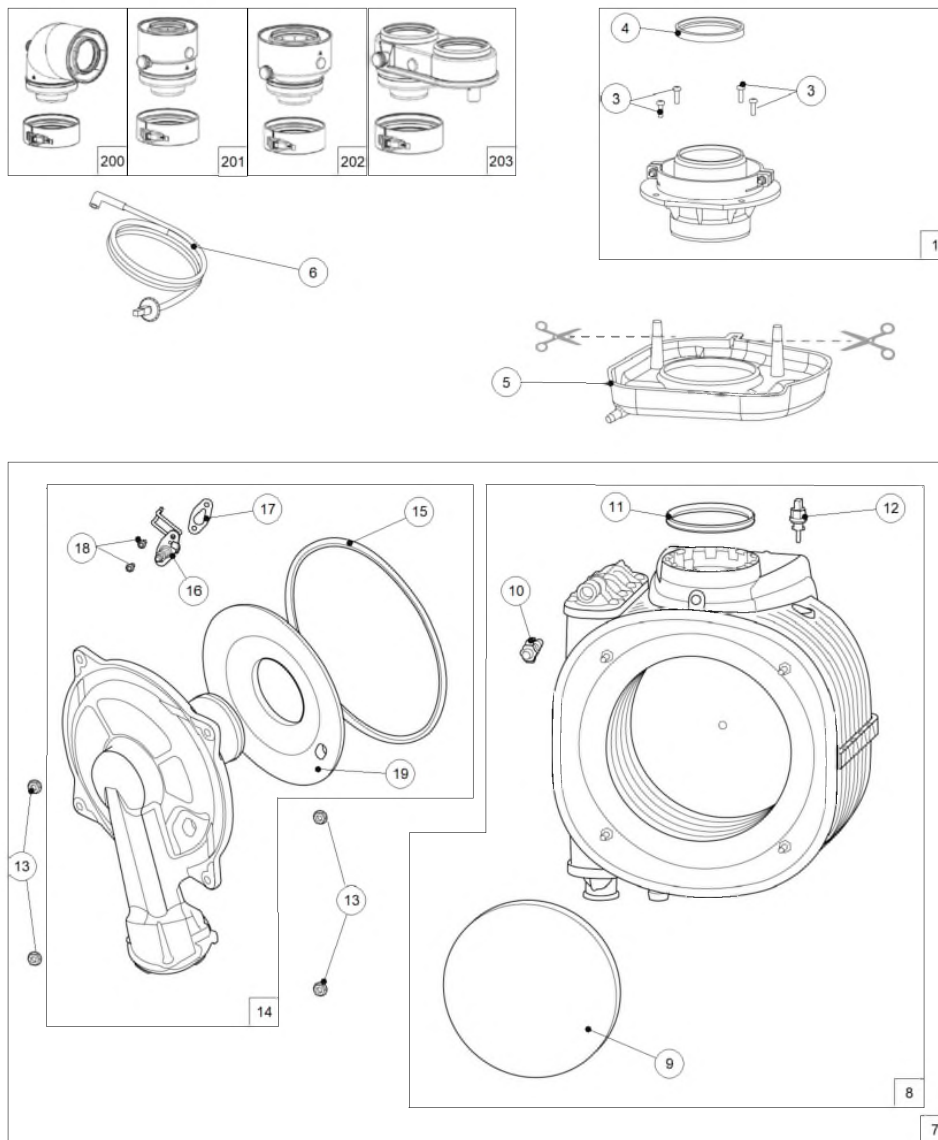



Casing

	Code	Quant.	Photo	Description	De --- A ---	Remarque
80	937403	1		Façade	15-02-22-	600 Ilea Complet
81	923245	1		Volet avec enjoliveur et amortisseur	15-02-22-	
82	157320	4		Passe fils M16	15-02-22-	M16
83	913922	1		Côté droit	15-02-22-	
84	913921	1		Côté gauche	15-02-22-	
85	205421	1		Support mural	15-02-22-	
147	174695	1		Pivot coffret	15-02-22-	
148	190045	2		Vis tôle	15-02-22-	TX20

Burner + heat exchanger









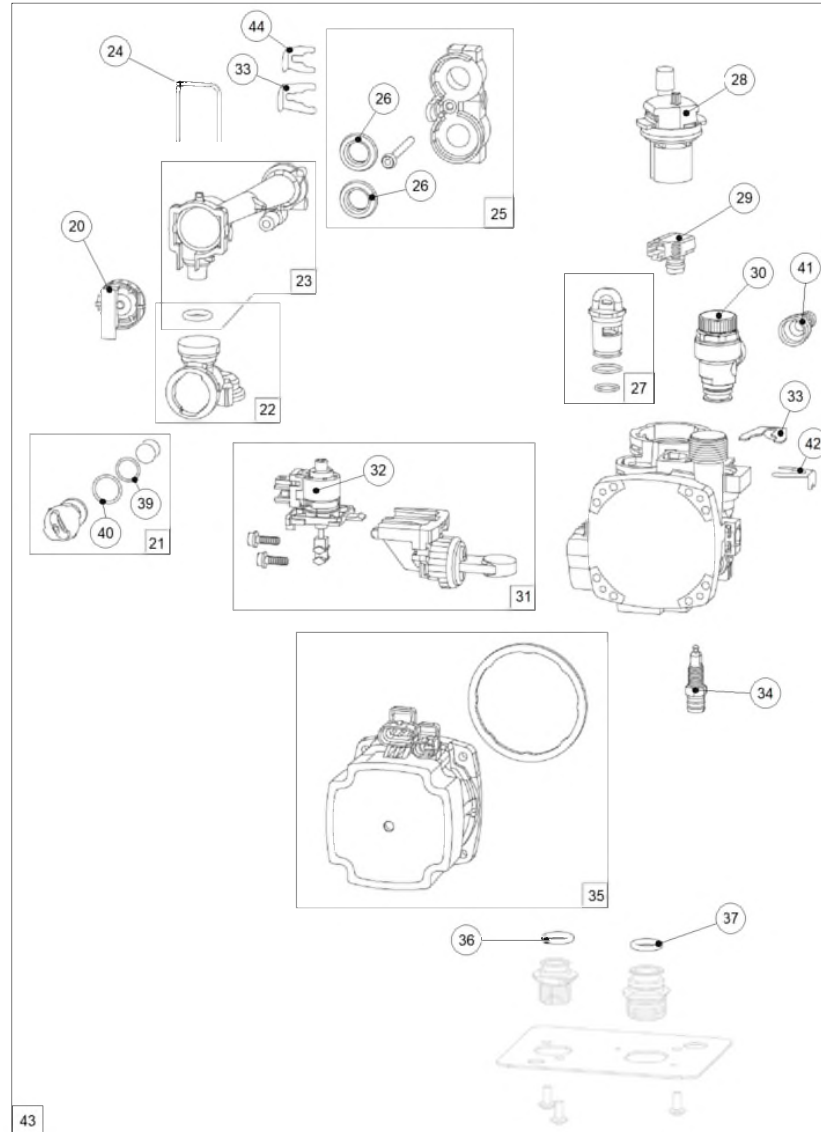









Burner + heat exchanger

Code	Code GA	Quant.	Photo	Description	De --- A ---	Remarque
1	100835	1		Adaptateur fumées	15-02-22-	
3	190045	4		Vis tôle	15-02-22-	
4	142517	1		Joint	15-02-22-	
5	164544	1		Récupérateur eau de pluie* 3+1	15-02-22-	
6	109223	1		Câble d'allumage	15-02-22-	
7	122054	1		Échangeur + brûleur 4+1	15-02-22-	4+1
8	122052	1		Échangeur 4+1	15-02-22-	4+1
9	140641	1		Isolant déélecteur	15-02-22-	
10	159063	1		Purgeur manuel	15-02-22-	
11	142476	1		Joint sortie échangeur d,80	15-02-22-	D.80
12	198787	1		Sonde sécurité fumée	15-02-22-	
13	122215	4		Écrou M6X1	15-02-22-	M6X1
14	159066	1		Porte froide brûleur 4+1	15-02-22-	4+1
15	142525	1		Joint porte froide	15-02-22-	
19	141036	1		Isolant porte froide	15-02-22-	
50	923007	923007		Électrode d'allumage - ionisation + Joint + Vis / Ontstekings- en ionisatie-elektrode + Dichting + Schroef / Zünd- und Ionisationselektrode + Dichtung +Schraube	15-02-22-	
200	A1007122	780267		Coude 90 °+ orifice -Ø (60/100) + Collier de serrage	15-02-22-	
201	A1007123	780268		Adaptateur + orifice -Ø (60/100) + Collier de serrage	15-02-22-	
202	A1007124	780269		Adaptateur + orifice -Ø (60/100) - Ø (80/125) + Collier de serrage	15-02-22-	
203	A1007125	780270		Twin Box PP + orifice Adapter -Ø (80/80) +Collier de serrage	15-02-22-	

Hydrobloc



Hydrobloc

Code	Quant.	Photo	Description	De --- A ---	Remarque
20	104737	1	Bouchon	15-02-22-	
21	110129	1	 Clapet antiretour	15-02-22-	Jaune
22	135030	1	 Groupe arrivée EFS	15-02-22-	
23	119445	1	 Logement débitmètre	15-02-22-	
24	100196	1	 Agrafe	15-02-22-	
25	100197	1	 Adaptateur + joint	15-02-22-	
26	142459	2	 Joint échangeur à plaques	15-02-22-	
27	104719	1	 Bouchon Solo-Combi	15-02-22-	
28	159441	1	 Purgeur	15-02-22-	
29	159813	1	Capteur de pression	15-02-22-	
30	174434	1	 Soupape	15-02-22-	
31	150313	1	 Vanne 3 voies + clapet	15-02-22-	
32	150331	1	 Moteur vanne 3 voies	15-02-22-	
33	100187	2	 Agrafe D18	15-02-22-	D18 lg
34	190046	1	 Vis de vidange	15-02-22-	
35	109984	1	Circulateur avec joint 6m	15-02-22-	
36	142790	1	 Joint torique 9,8x3,6 Ilea	15-02-22-	19,8x3,6
37	142791	1	 Joint torique 16x3 Ilea	15-02-22-	16x3
39	142793	1	 Joint torique 15,6x1,78 Ilea	15-02-22-	15,6x7,78
40	142794	1	 Joint torique 19x2 Ilea	15-02-22-	19x2



Hydrobloc

	Code	Quant.	Photo	Description	De --- A ---	Remarque
41	164279	1		Douille cannelée	15-02-22-	
42	110126	1		Agrafe D9	15-02-22-	D9 lg
43	138001	1		Hydrobloc	15-02-22-	
44	110369	1		Agrafe D15	15-02-22-	D15

Electrical box

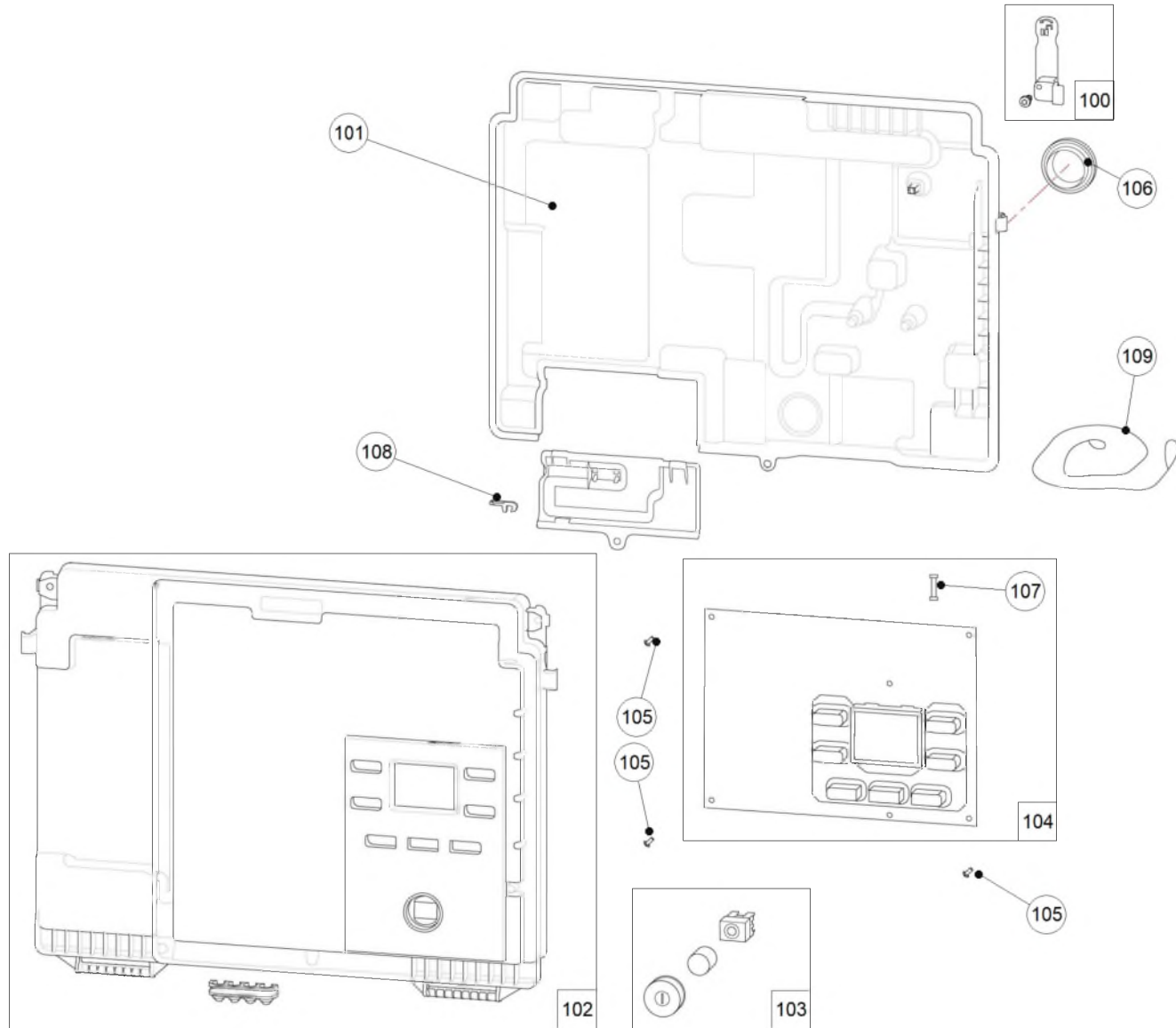



Electrical box



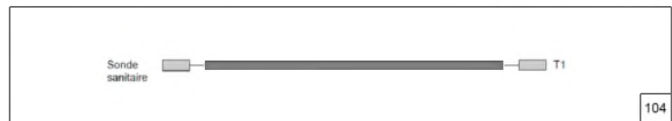
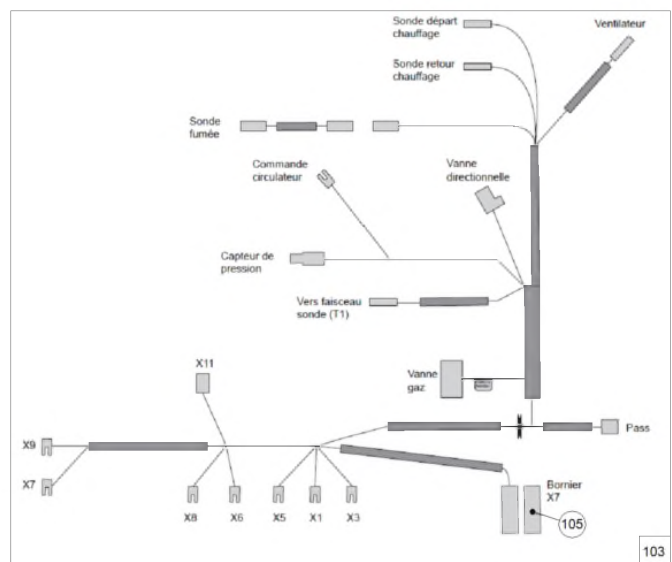
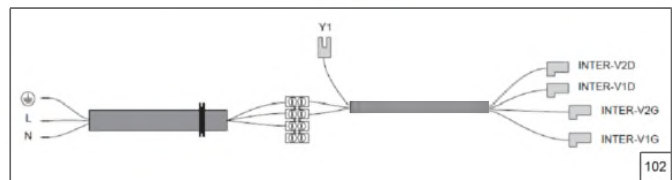
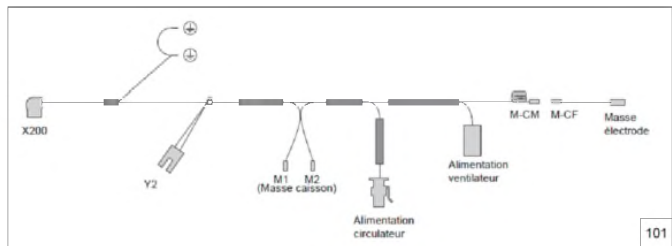

Code	Code GA	Quant.	Photo	Description	De --- A ---	Remarque
100	236910	1		Verrou quart de tour + vis	15-02-22-	
101	977094	1		Coffret arrière	15-02-22-	
102	978915	1		Coffret avant	15-02-22-	
103	943021	1		Interrupteur M/A	15-02-22-	
104	965437	965437		CONTROLLER ILEA EXCELLENCE 25/35 BE	15-02-22-	ILEA EXCELLENCE 25/35 BE
105	190064	3		Vis carte de régulation	15-02-22-	
106	104740	1		Bouchon	15-02-22-	
107	199925	1		Fusible 15	15-02-22-	F3.15AL250VP ou T3.15AH250V
108	158624	1		Levier	15-02-22-	
109	148005	1		Cordelette de sécurité	15-02-22-	

Wiring





Wiring

	Code	Quant.	Photo	Description	De --- A ---
101	109364	1		Faisceau 230V	15-02-22-
102	109353	1		Faisceau 230V alimentation	15-02-22-
103	109661	1		Faisceau 24V	15-02-22-
104	109370	1		Faisceau sonde	15-02-22-
105	110709	1		Connecteur (branchement installateur)	15-02-22-

Hydro connection kit (bottom connection)

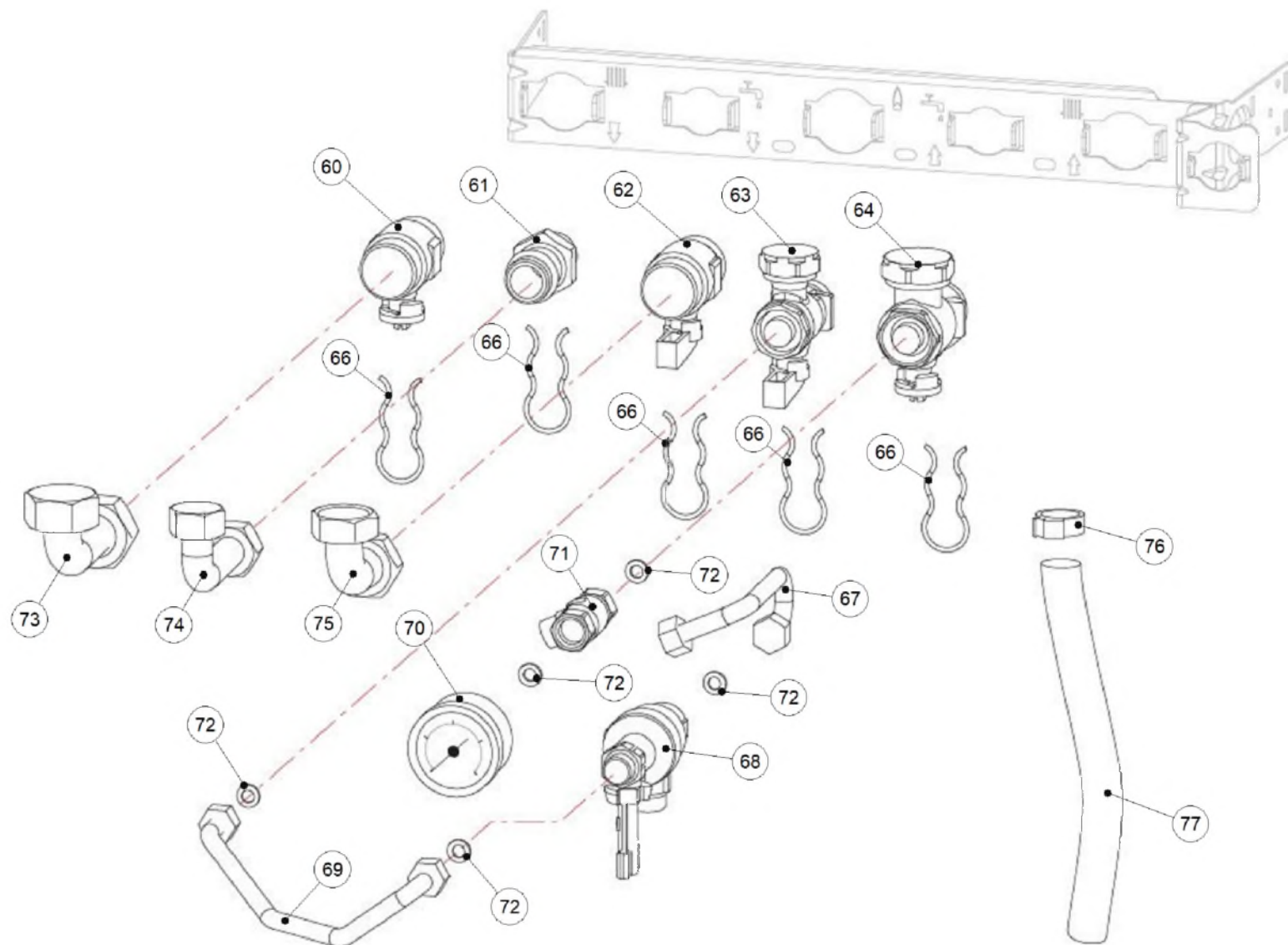









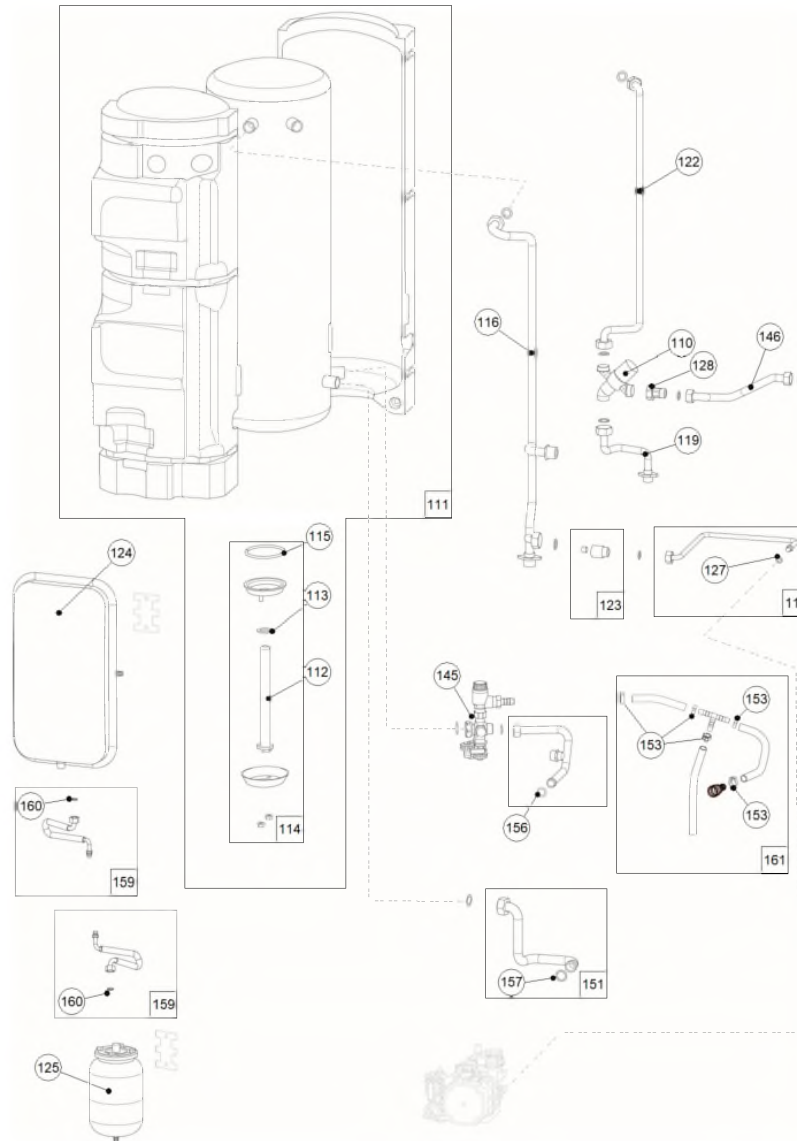

Hydro connection kit (bottom connection)

Code	Code GA	Quant.	Photo	Description	De --- A ---	Remarque
60	188903	1		Vanne départ installation	15-02-22-	
61	164249	1		Raccord laiton ECS	15-02-22-	
62	188279	188279	1	Robinet gaz ARGB / Gaskraan ARGB / Gasventil ARGB	15-02-22-	
63	188901	1		Vanne arrivée EFS	15-02-22-	
64	188900	1		Vanne retour installation	15-02-22-	
66	134607	5		Goupille	15-02-22-	
67	182541	1		Tube sortie disconnecteur	15-02-22-	
68	119528	1		Disconnecteur	15-02-22-	
69	182446	1		Tube entrée disconnecteur Solo-Combi	15-02-22-	
70	149948	1		Manomètre	15-02-22-	
71	177546	1		Té 1/4"	15-02-22-	"1/4""
72	142912	5		Joint disconnecteur	15-02-22-	
73	182785	1		Coude (départ chauffage)	15-02-22-	
74	182778	1		Coude (départ ECS)	15-02-22-	
75	182585	182585	1	Coude (gaz) - Bocht (gas) - Winkelstück (Gas)	15-02-22-	
76	134608	1		Bague de serrage	15-02-22-	
77	182730	1		Tube évacuation	15-02-22-	
86	142442	5		Joint 3/4-20/27	15-02-22-	"3/4""
87	142723	5		Joint	15-02-22-	"1/2""

Domestic hot water tank







Domestic hot water tank

	Code	Quant.	Photo	Description	De --- A ---	Remarque
110	150173	1		Mitigeur thermostatique	15-02-22-	
111	102079	1		Ballon serpentin	15-02-22-	
112	100331	1		Anode	15-02-22-	
113	142516	1		Joint anode	15-02-22-	
114	181140	1		Trappe complète	15-02-22-	
115	142515	1		Joint trappe	15-02-22-	
116	182748	1		Tuyauterie départ chauffage	15-02-22-	
117	982438	1		Tube bipasse + joint torique	15-02-22-	
119	182747	1		Tuyauterie départ ECS	15-02-22-	
122	182749	1		Tuyauterie ballon / mitigeur	15-02-22-	
124	188271	1		Vase expansion 10L	15-02-22-	10L
125	188263	1		Vase expansion sanitaire 2L	15-02-22-	2L
127	142717	1		Joint torique 9,5x2,7	15-02-22-	9,5x2,7
128	110098	1		Clapet mitigeur	15-02-22-	
145	174439	1		Bloc laiton soupape + vidange	15-02-22-	
146	182750	1		Tube eau froide mitigeur	15-02-22-	
151	982433	1		Tuyauterie retour ballon + joint torique	15-02-22-	
152	982434	1		Tube arrivée EFS + joint torique	15-02-22-	
153	174215	5		Collier de serrage nylon d15-17,2	15-02-22-	D15-17,2
156	142294	1		Joint 14x3	15-02-22-	



Domestic hot water tank

		Code	Quant.	Photo	Description	De --- A ---	Remarque
157		142716	2		Joint 18x2,8	15-02-22-	18x2,8
159		982009	2		Flexible + joints	15-02-22-	
160		142721	2		Joint 12X17	15-02-22-	12x17
161		982442	1		Té + tubes	15-02-22-	