



Thermor

Produits

Référence	Nom	Lettre
296504	AEROMAX SPLIT VS 300L	A

Basculement en anode hybride à partir du numéro de série 1210A0220. Capot modifié à partir de 13.29

Paramètres

Référence	Capacité/Largeur	Tension (V)	Puissance(W)	Lettre
296504	300	230	1800	A

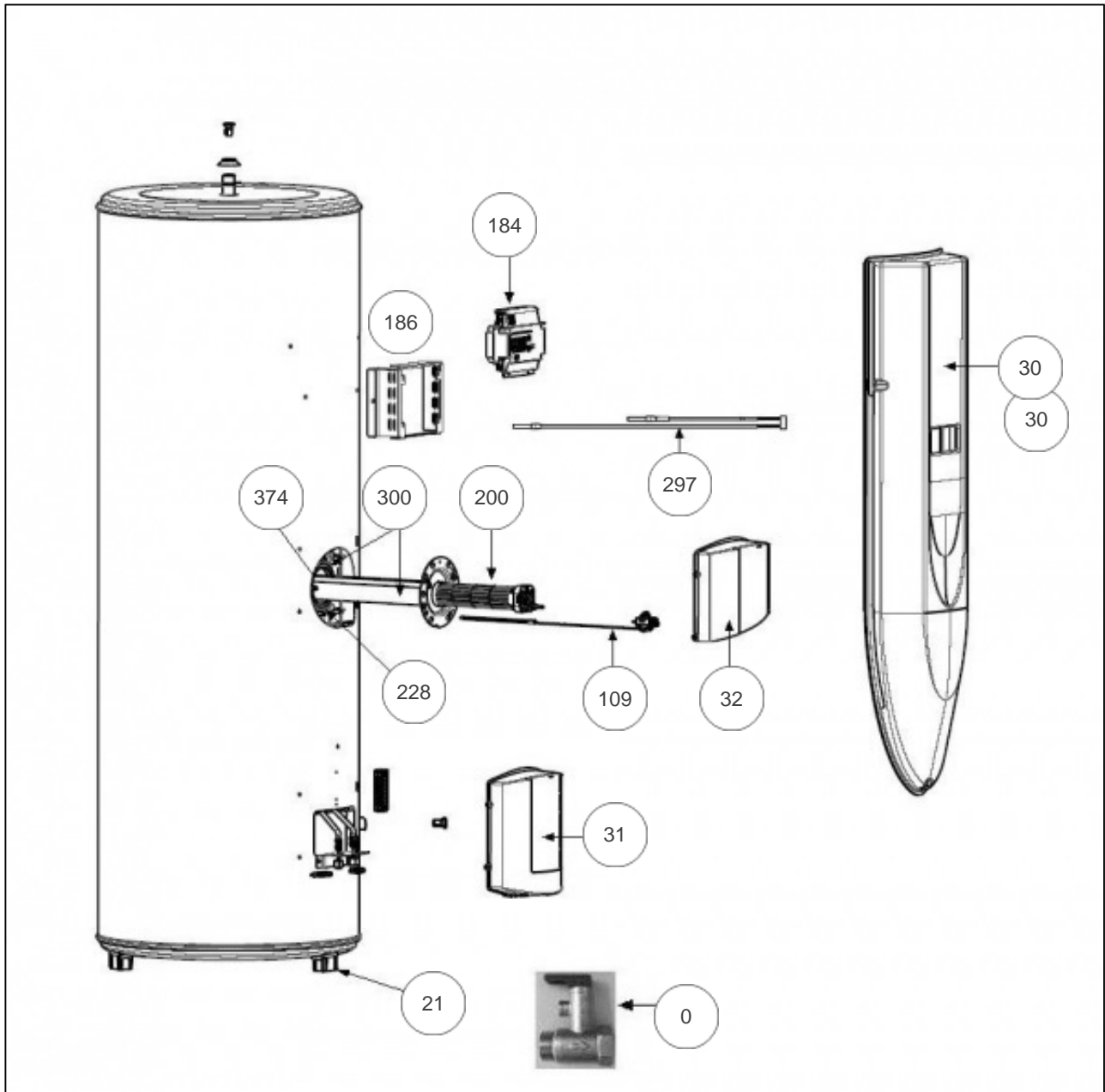



Références

Repère	Libellé	A
0	VALVULA 3/4 8 BARS (BLANCHE)	029518
21	PIED FIXE + VISSERIE (BLANC)	022495
30	CAPOT DE FACADE (SPLIT VS THERMOR) ->13.29	022491
30	CAPOT DE FACADE (SPLIT 2 VS THERMOR) 13.29->	022588
31	CAPOT LIAISON FRIGO (SPLIT VS) ->13.29	022492
32	CAPOT ELECTRIQUE (SPLIT VS) ->13.29	022493
109	SECURITE MECA 90DEG SBLC0049 + BARRETTES	030264
184	BOITIER ELECT. DE REGULATION (SPLIT)	070320
186	BORNIER ELECTRIQUE + FILERIE SPLIT 300L	026129
200	RESISTANCE STEATITE 1800W MONO	099024
228	JOINT A LEVRE D.82MM	099060
297	FAISCEAU DE SONDAS (SPLIT 200-300L)	026130
300	CORPS DE CHAUFFE + JOINT ACI HYB. <i>Si remplacement du corps de chauffe, prévoir la sécurité méca 030264 / If you replace the heating body, also change the safety thermostat 030264</i>	030147
374	ANODE ACI + BOUCHON	040374