

1-12. INDOOR UNIT HEAT EXCHANGER

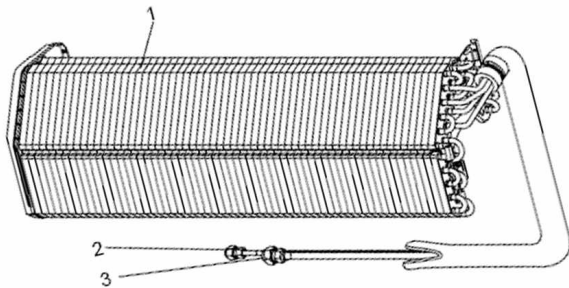

MSZ-EF18VE2W -[ER1] MSZ-EF22VE2W -[ER1] MSZ-EF25VE2W -[ER1]

MSZ-EF18VE2B -[ER1] MSZ-EF22VE2B -[ER1] MSZ-EF25VE2B -[ER1]

MSZ-EF18VE2S -[ER1] MSZ-EF22VE2S -[ER1] MSZ-EF25VE2S -[ER1]

MSZ-EF35VE2W -[ER1] MSZ-EF42VE2W -[ER1] MSZ-EF50VE2W -[ER1]

MSZ-EF35VE2B -[ER1] MSZ-EF42VE2B -[ER1] MSZ-EF50VE2B -[ER1]

MSZ-EF35VE2S -[ER1] MSZ-EF42VE2S -[ER1] MSZ-EF50VE2S -[ER1]

## 1-11. INDOOR UNIT ELECTRICAL PARTS AND FUNCTIONAL PARTS

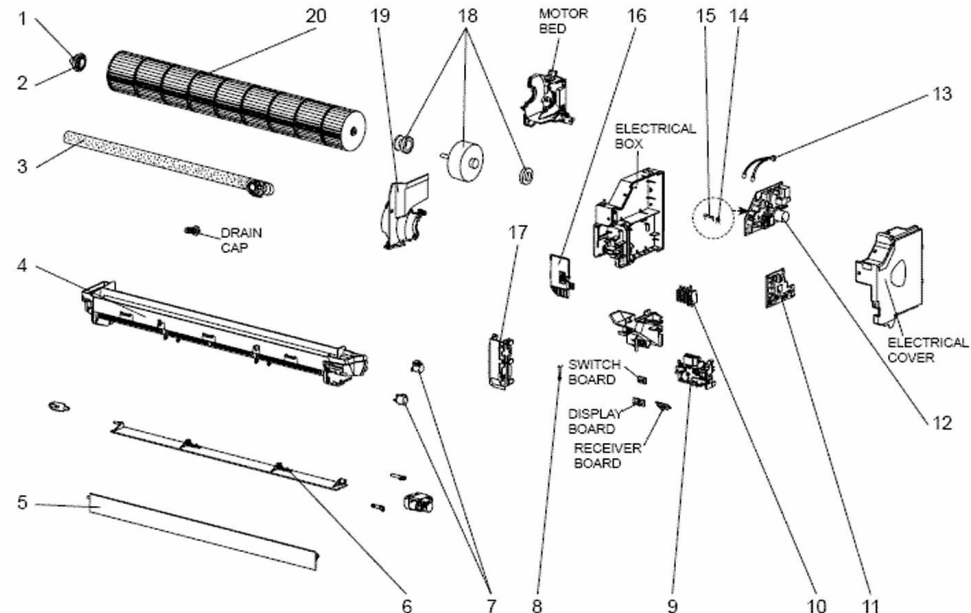

MSZ-EF18VE2W -[ER1] MSZ-EF22VE2W -[ER1] MSZ-EF25VE2W -[ER1]  
 MSZ-EF18VE2B -[ER1] MSZ-EF22VE2B -[ER1] MSZ-EF25VE2B -[ER1]  
 MSZ-EF18VE2S -[ER1] MSZ-EF22VE2S -[ER1] MSZ-EF25VE2S -[ER1]  
 MSZ-EF35VE2W -[ER1] MSZ-EF42VE2W -[ER1] MSZ-EF50VE2W -[ER1]  
 MSZ-EF35VE2B -[ER1] MSZ-EF42VE2B -[ER1] MSZ-EF50VE2B -[ER1]  
 MSZ-EF35VE2S -[ER1] MSZ-EF42VE2S -[ER1] MSZ-EF50VE2S -[ER1]

### 1-9. INDOOR UNIT STRUCTURAL PARTS

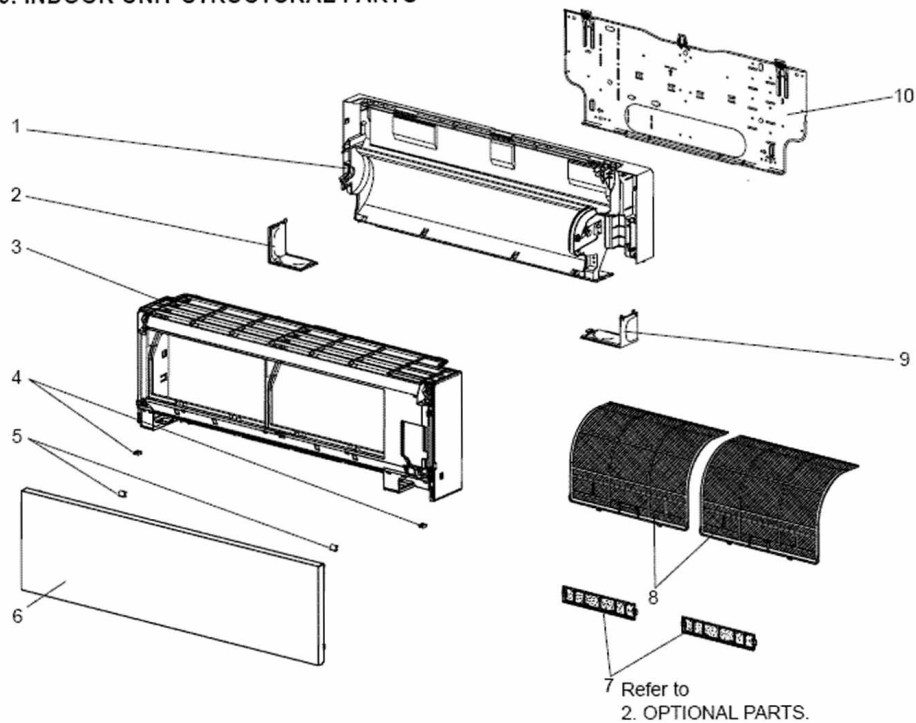

### 1-10. ACCESSORY AND REMOTE CONTROLLER

