

MSZ-EF18VE3W - [E] MSZ-EF22VE3W - [E] MSZ-EF25VE3W - [E]
 MSZ-EF18VE3B - [E] MSZ-EF22VE3B - [E] MSZ-EF25VE3B - [E]
 MSZ-EF18VE3S - [E] MSZ-EF22VE3S - [E] MSZ-EF25VE3S - [E]
 MSZ-EF35VE3W - [E] MSZ-EF42VE3W - [E] MSZ-EF50VE3W - [E]
 MSZ-EF35VE3B - [E] MSZ-EF42VE3B - [E] MSZ-EF50VE3B - [E]
 MSZ-EF35VE3S - [E] MSZ-EF42VE3S - [E] MSZ-EF50VE3S - [E]

1-18. INDOOR UNIT ELECTRICAL PARTS AND FUNCTIONAL PARTS

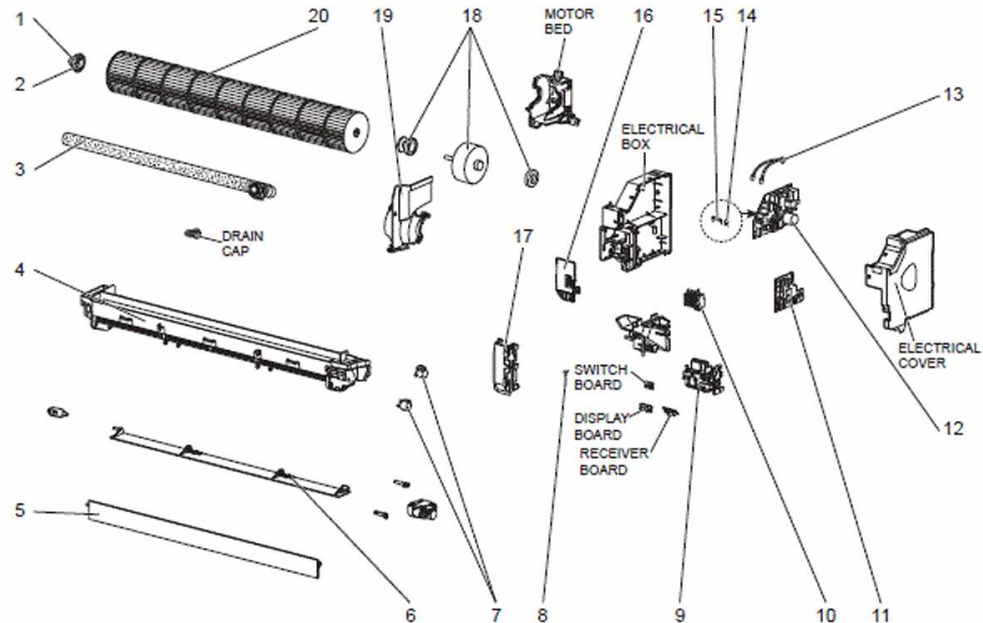

1-19. INDOOR UNIT HEAT EXCHANGER

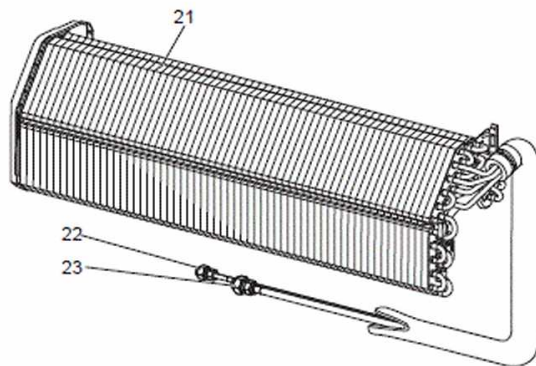

MSZ-EF18VE3W - [E] MSZ-EF22VE3W - [E] MSZ-EF25VE3W - [E]
 MSZ-EF18VE3B - [E] MSZ-EF22VE3B - [E] MSZ-EF25VE3B - [E]
 MSZ-EF18VE3S - [E] MSZ-EF22VE3S - [E] MSZ-EF25VE3S - [E]
 MSZ-EF35VE3W - [E] MSZ-EF42VE3W - [E] MSZ-EF50VE3W - [E]
 MSZ-EF35VE3B - [E] MSZ-EF42VE3B - [E] MSZ-EF50VE3B - [E]
 MSZ-EF35VE3S - [E] MSZ-EF42VE3S - [E] MSZ-EF50VE3S - [E]

1-16. INDOOR UNIT STRUCTURAL PARTS

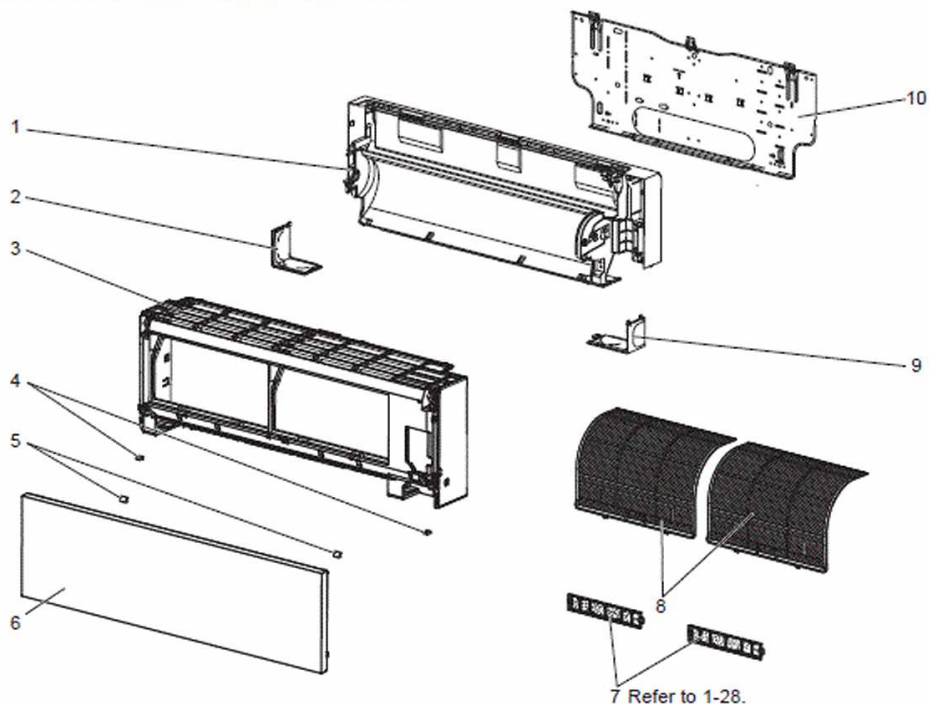

1-17. ACCESSORY AND REMOTE CONTROLLER

