

MSZ-EF18VE3W -[E1] MSZ-EF22VE3W -[E1] MSZ-EF25VE3W -[E1]
 MSZ-EF18VE3B -[E1] MSZ-EF22VE3B -[E1] MSZ-EF25VE3B -[E1]
 MSZ-EF18VE3S -[E1] MSZ-EF22VE3S -[E1] MSZ-EF25VE3S -[E1]
 MSZ-EF35VE3W -[E1] MSZ-EF42VE3W -[E1] MSZ-EF50VE3W -[E1]
 MSZ-EF35VE3B -[E1] MSZ-EF42VE3B -[E1] MSZ-EF50VE3B -[E1]
 MSZ-EF35VE3S -[E1] MSZ-EF42VE3S -[E1] MSZ-EF50VE3S -[E1]

1-14. INDOOR UNIT ELECTRICAL PARTS AND FUNCTIONAL PARTS

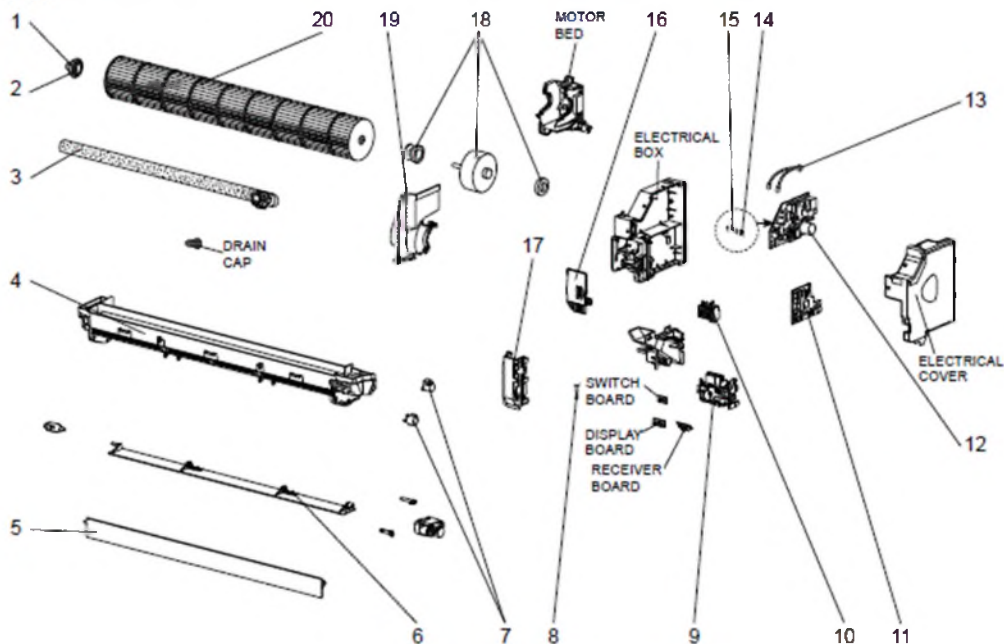

1-15. INDOOR UNIT HEAT EXCHANGER

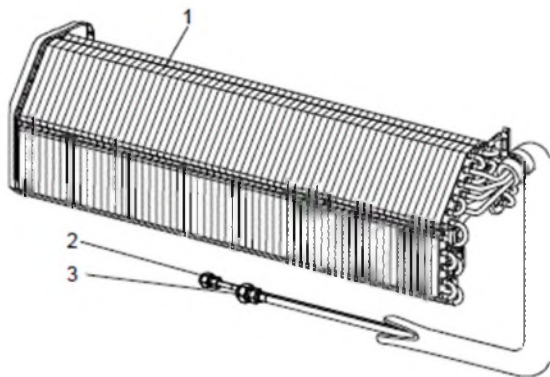

MSZ-EF18VE3W -[ET] MSZ-EF22VE3W -[ET] MSZ-EF25VE3W -[ET]
 MSZ-EF18VE3B -[ET] MSZ-EF22VE3B -[ET] MSZ-EF25VE3B -[ET]
 MSZ-EF18VE3S -[ET] MSZ-EF22VE3S -[ET] MSZ-EF25VE3S -[ET]
 MSZ-EF35VE3W -[ET] MSZ-EF42VE3W -[ET] MSZ-EF50VE3W -[ET]
 MSZ-EF35VE3B -[ET] MSZ-EF42VE3B -[ET] MSZ-EF50VE3B -[ET]
 MSZ-EF35VE3S -[ET] MSZ-EF42VE3S -[ET] MSZ-EF50VE3S -[ET]

1-12. INDOOR UNIT STRUCTURAL PARTS

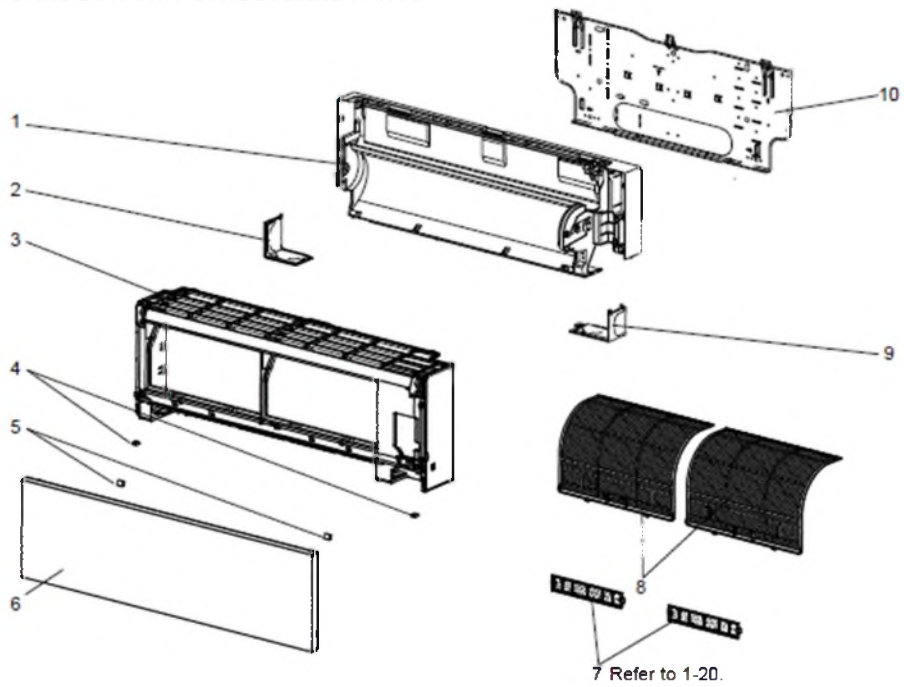

1-13. ACCESSORY AND REMOTE CONTROLLER

