

MSZ-EF18VGKW - [E] MSZ-EF18VGKB - [E] MSZ-EF18VGKS - [E]
 MSZ-EF22VGKW - [E] MSZ-EF22VGKB - [E] MSZ-EF22VGKS - [E]
 MSZ-EF25VGKW - [E] MSZ-EF25VGKB - [E] MSZ-EF25VGKS - [E]
 MSZ-EF35VGKW - [E] MSZ-EF35VGKB - [E] MSZ-EF35VGKS - [E]
 MSZ-EF42VGKW - [E] MSZ-EF42VGKB - [E] MSZ-EF42VGKS - [E]
 MSZ-EF50VGKW - [E] MSZ-EF50VGKB - [E] MSZ-EF50VGKS - [E]

1-19. INDOOR UNIT ELECTRICAL PARTS AND FUNCTIONAL PARTS

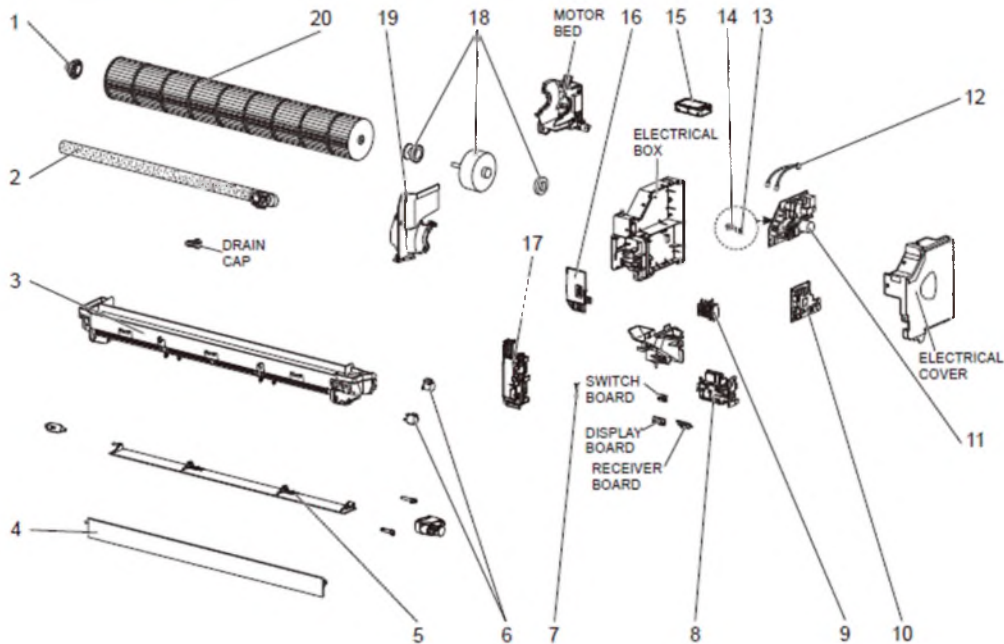

MSZ-EF18VGKW · ㊦ MSZ-EF18VGKB · ㊦ MSZ-EF18VGKS · ㊦
 MSZ-EF22VGKW · ㊦ MSZ-EF22VGKB · ㊦ MSZ-EF22VGKS · ㊦
 MSZ-EF25VGKW · ㊦ MSZ-EF25VGKB · ㊦ MSZ-EF25VGKS · ㊦
 MSZ-EF35VGKW · ㊦ MSZ-EF35VGKB · ㊦ MSZ-EF35VGKS · ㊦
 MSZ-EF42VGKW · ㊦ MSZ-EF42VGKB · ㊦ MSZ-EF42VGKS · ㊦
 MSZ-EF50VGKW · ㊦ MSZ-EF50VGKB · ㊦ MSZ-EF50VGKS · ㊦

1-17. INDOOR UNIT STRUCTURAL PARTS

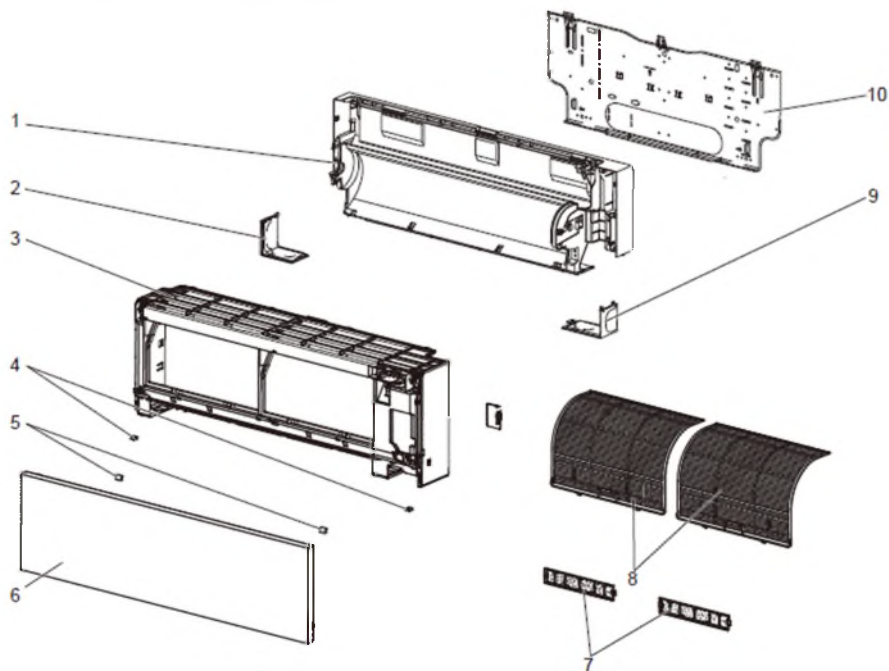

1-18. ACCESSORY AND REMOTE CONTROLLER

