

MSZ-EF18VGW - ㊦ MSZ-EF18VGB - ㊦ MSZ-EF18VGS - ㊦
 MSZ-EF22VGW - ㊦ MSZ-EF22VGB - ㊦ MSZ-EF22VGS - ㊦
 MSZ-EF25VGW - ㊦ MSZ-EF25VGB - ㊦ MSZ-EF25VGS - ㊦
 MSZ-EF35VGW - ㊦ MSZ-EF35VGB - ㊦ MSZ-EF35VGS - ㊦
 MSZ-EF42VGW - ㊦ MSZ-EF42VGB - ㊦ MSZ-EF42VGS - ㊦
 MSZ-EF50VGW - ㊦ MSZ-EF50VGB - ㊦ MSZ-EF50VGS - ㊦

1-3. INDOOR UNIT ELECTRICAL PARTS AND FUNCTIONAL PARTS

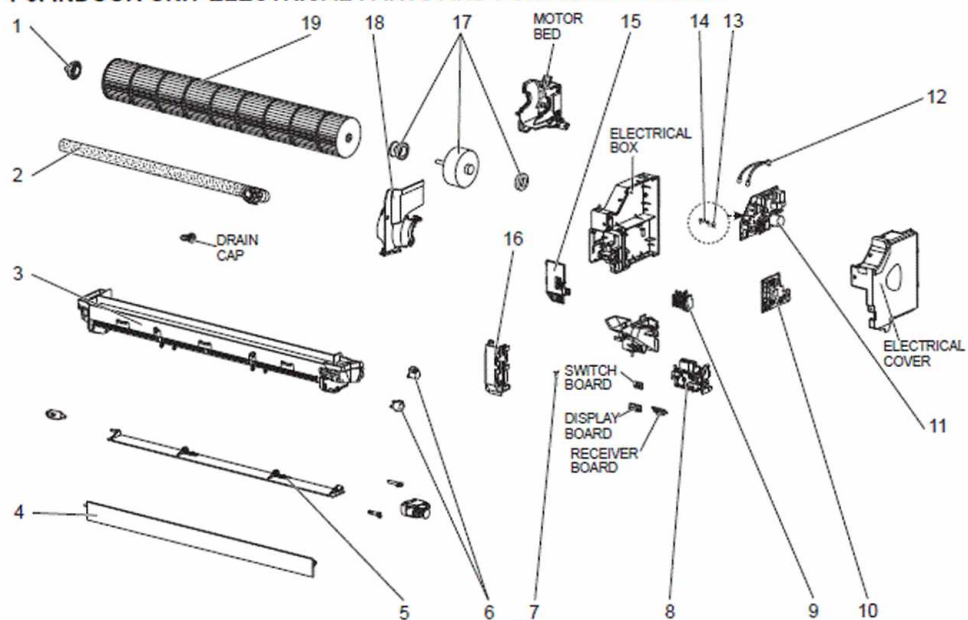

1-4. INDOOR UNIT HEAT EXCHANGER

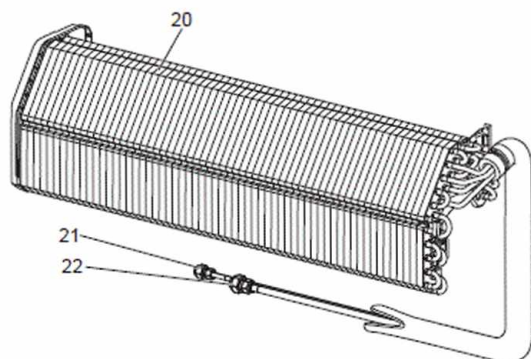

MSZ-EF18VGW - ㉔ MSZ-EF18VGB - ㉔ MSZ-EF18VGS - ㉔
 MSZ-EF22VGW - ㉔ MSZ-EF22VGB - ㉔ MSZ-EF22VGS - ㉔
 MSZ-EF25VGW - ㉔ MSZ-EF25VGB - ㉔ MSZ-EF25VGS - ㉔
 MSZ-EF35VGW - ㉔ MSZ-EF35VGB - ㉔ MSZ-EF35VGS - ㉔
 MSZ-EF42VGW - ㉔ MSZ-EF42VGB - ㉔ MSZ-EF42VGS - ㉔
 MSZ-EF50VGW - ㉔ MSZ-EF50VGB - ㉔ MSZ-EF50VGS - ㉔

1-1. INDOOR UNIT STRUCTURAL PARTS

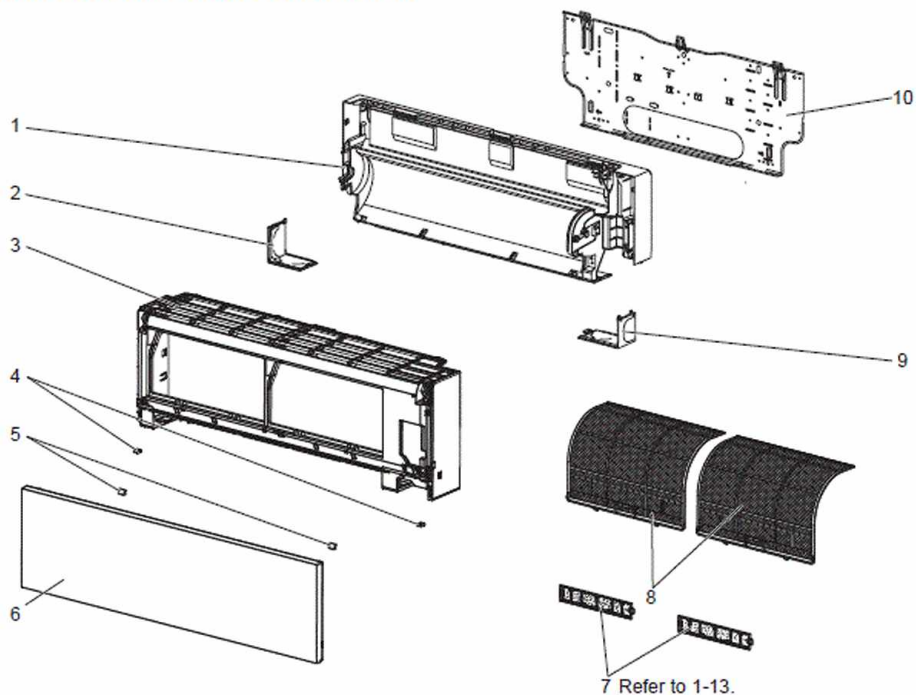

1-2. ACCESSORY AND REMOTE CONTROLLER

