

MSZ-EF18VE3W -[E] MSZ-EF22VE3W -[E] MSZ-EF25VE3W -[E]
 MSZ-EF18VE3B -[E] MSZ-EF22VE3B -[E] MSZ-EF25VE3B -[E]
 MSZ-EF18VE3S -[E] MSZ-EF22VE3S -[E] MSZ-EF25VE3S -[E]
 MSZ-EF35VE3W -[E] MSZ-EF42VE3W -[E] MSZ-EF50VE3W -[E]
 MSZ-EF35VE3B -[E] MSZ-EF42VE3B -[E] MSZ-EF50VE3B -[E]
 MSZ-EF35VE3S -[E] MSZ-EF42VE3S -[E] MSZ-EF50VE3S -[E]

1-14. INDOOR UNIT ELECTRICAL PARTS AND FUNCTIONAL PARTS

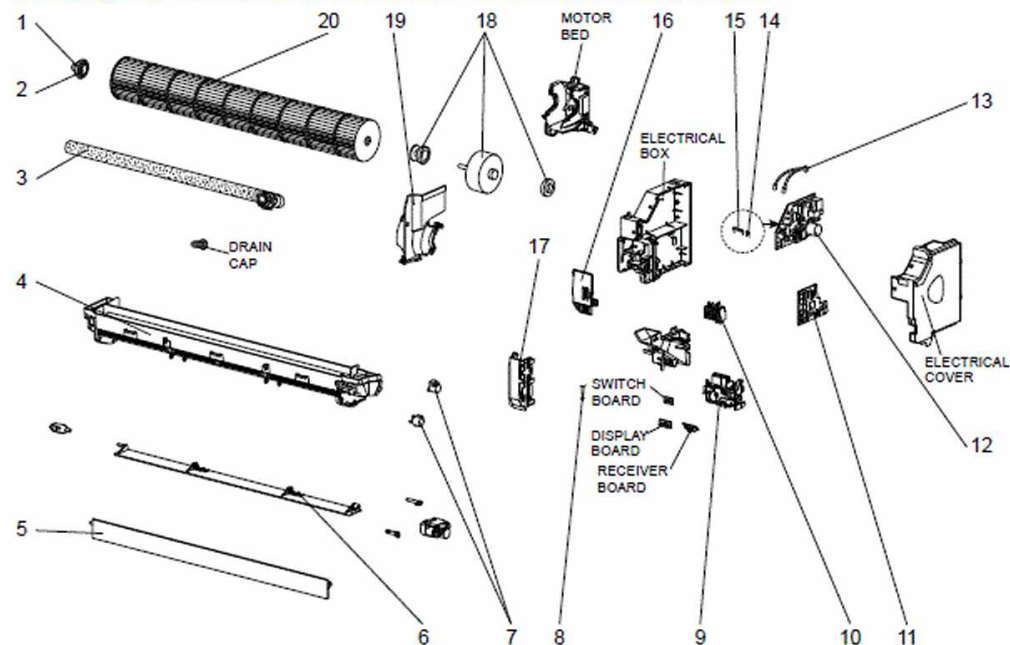

1-15. INDOOR UNIT HEAT EXCHANGER

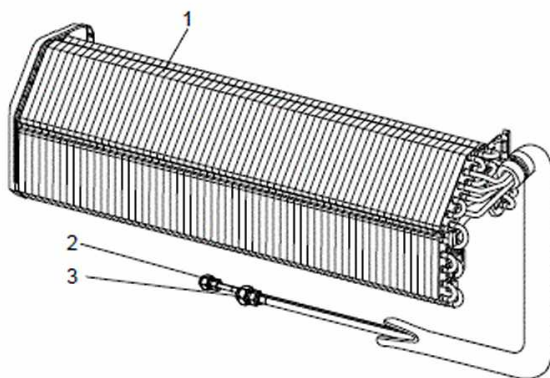

MSZ-EF18VE3W -E MSZ-EF22VE3W -E MSZ-EF25VE3W -E
 MSZ-EF18VE3B -E MSZ-EF22VE3B -E MSZ-EF25VE3B -E
 MSZ-EF18VE3S -E MSZ-EF22VE3S -E MSZ-EF25VE3S -E
 MSZ-EF35VE3W -E MSZ-EF42VE3W -E MSZ-EF50VE3W -E
 MSZ-EF35VE3B -E MSZ-EF42VE3B -E MSZ-EF50VE3B -E
 MSZ-EF35VE3S -E MSZ-EF42VE3S -E MSZ-EF50VE3S -E

1-12. INDOOR UNIT STRUCTURAL PARTS

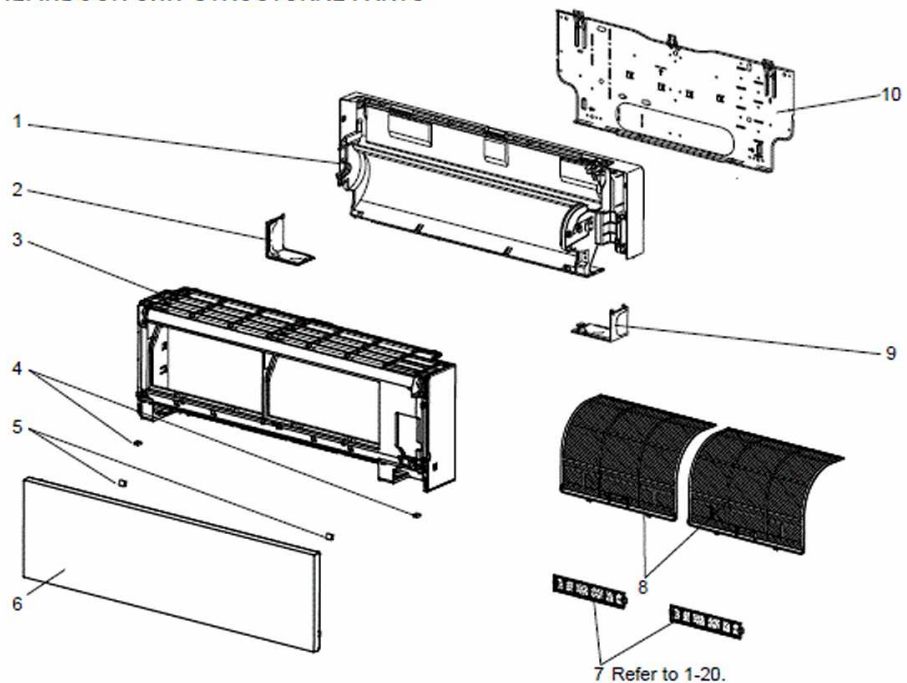

1-13. ACCESSORY AND REMOTE CONTROLLER

