

- MSZ-EF18VE2W -[E1] MSZ-EF22VE2W -[E1] MSZ-EF25VE2W -[E1]
- MSZ-EF18VE2B -[E1] MSZ-EF22VE2B -[E1] MSZ-EF25VE2B -[E1]
- MSZ-EF18VE2S -[E1] MSZ-EF22VE2S -[E1] MSZ-EF25VE2S -[E1]
- MSZ-EF35VE2W -[E1] MSZ-EF42VE2W -[E1] MSZ-EF50VE2W -[E1]
- MSZ-EF35VE2B -[E1] MSZ-EF42VE2B -[E1] MSZ-EF50VE2B -[E1]
- MSZ-EF35VE2S -[E1] MSZ-EF42VE2S -[E1] MSZ-EF50VE2S -[E1]

### 1-7. INDOOR UNIT ELECTRICAL PARTS AND FUNCTIONAL PARTS

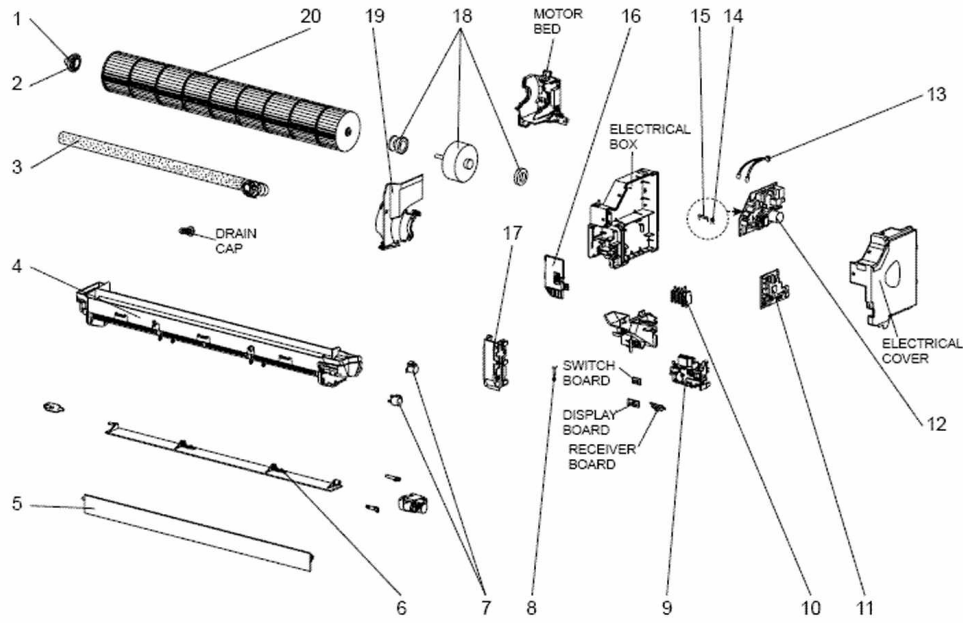

MSZ-EF18VE2W -[E1] MSZ-EF22VE2W -[E1] MSZ-EF25VE2W -[E1]  
 MSZ-EF18VE2B -[E1] MSZ-EF22VE2B -[E1] MSZ-EF25VE2B -[E1]  
 MSZ-EF18VE2S -[E1] MSZ-EF22VE2S -[E1] MSZ-EF25VE2S -[E1]  
 MSZ-EF35VE2W -[E1] MSZ-EF42VE2W -[E1] MSZ-EF50VE2W -[E1]  
 MSZ-EF35VE2B -[E1] MSZ-EF42VE2B -[E1] MSZ-EF50VE2B -[E1]  
 MSZ-EF35VE2S -[E1] MSZ-EF42VE2S -[E1] MSZ-EF50VE2S -[E1]

## 1-5. INDOOR UNIT STRUCTURAL PARTS

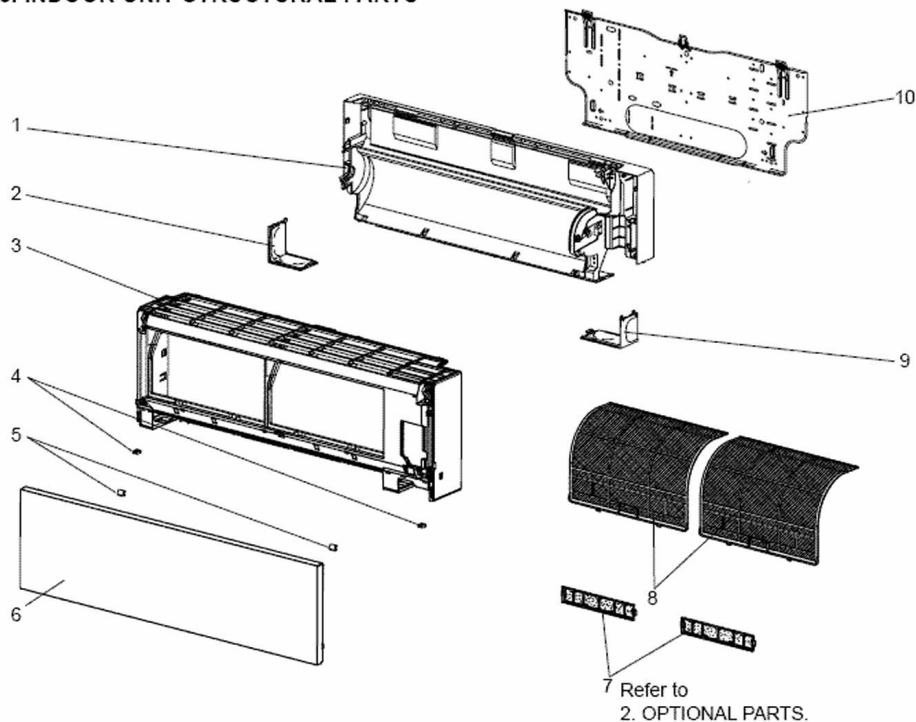

## 1-6. ACCESSORY AND REMOTE CONTROLLER

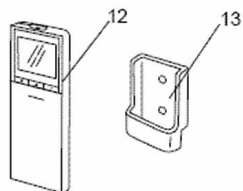

# 1-8. INDOOR UNIT HEAT EXCHANGER

