

MCZ GROUP

CLIO HYDRO 23/S

Componenti Struttura Esterna / External structure components / Bauteile Aussenkorpus / Composants structure externe / Componentes estructura externa

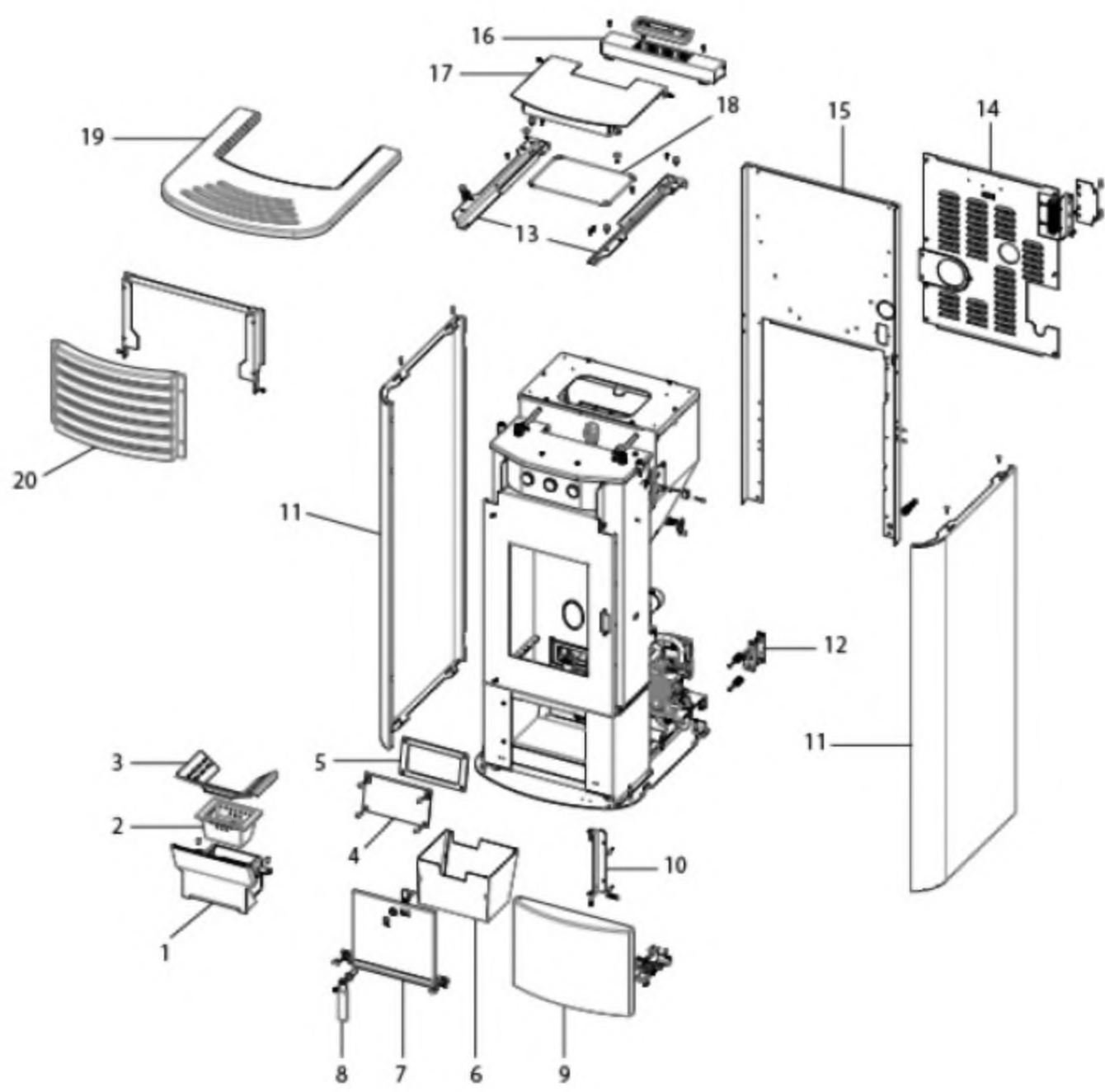

CLIO HYDRO 23/S

Componenti Struttura Esterna / External structure components / Bauteile Aussenkorpus / Composants structure externe / Componentes estructura externa

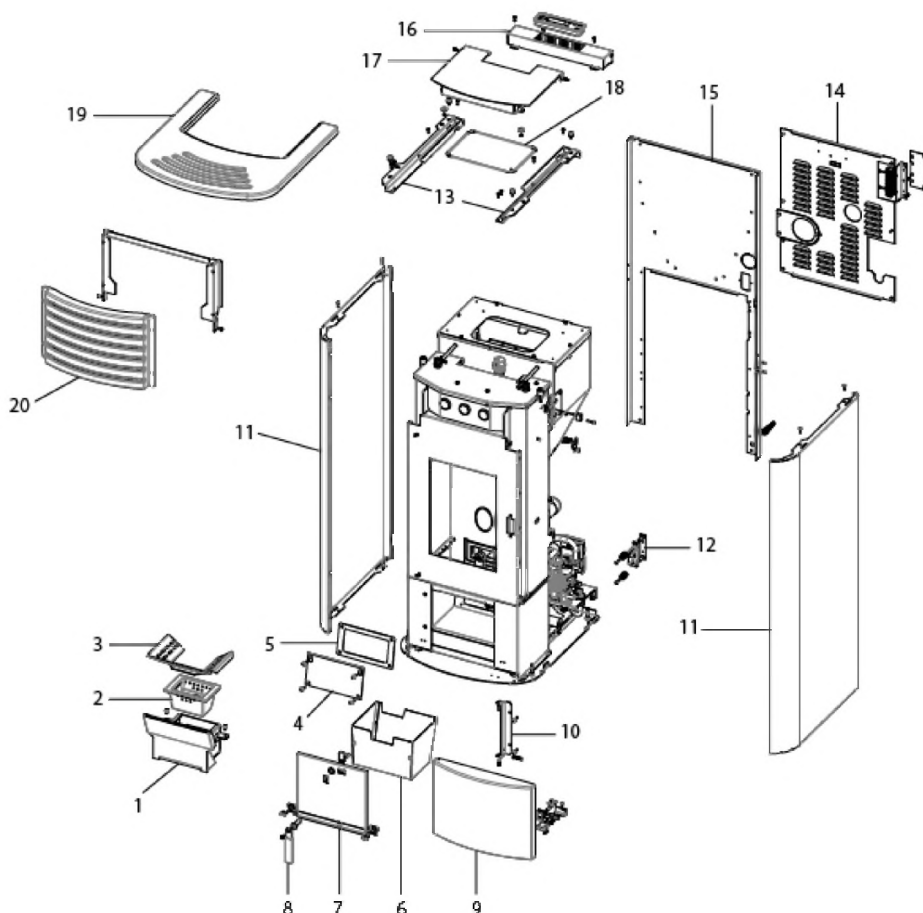

N°	Codice/Code	Descrizioni / Description / Beschreibung / Description / Description	Prezzo (€)
1	41411682441V	Tasca braciere / Combustion pot container / Brenntopfkasten / Récipient brasero / Contenedor brasero	192.00
2	41301602601V	Braciere ghisa / Cast iron brazier / Bernnschale aus Guß / Brasero en fonte / Brasero de arrabio	58.00
3	41411696230V	Scivolo braciere ghisa / Grate amp in cast iron / Brenntopf Rutsche aus Guß / Glissèrie brasero en fonte / Tobogán brasero en arrabio	59.00
4	41401605530	Tappo camera fumi zincato / Smoke compartment galvanized plug / Verzinktes Rauchabzugklappe / Join zingué compartiment fumées / Tapón galvanizado compartimento humos	20.00
5	41801601300	Guarnizione tappo camera fumi / Smoke compartment plug gasket / Dichtung Rauchabzugklappe / Joint clapet compartiment fumées / Junta tapón compatimento humos	19.00
6	437016041	Cassetto cenere / Ash drawer / Aschenkasten / Tiroir à cendres / Cajón ceniza	56.00
7	41421605640V	Porta cenere / Ash drawer door / Tür des Aschenkastens / Porte tiroir à cendres / Puerta cajón ceniza	54.00
7	437016077	Porta cassetto cenere / Ash drawer door / Tür des Aschenkastens / Porte tiroir à cendres / Puerta cajón ceniza	124.00
8	41411621600	Maniglia con impugnatura porta cenere / Handle / Griff / Poignée / Tirador	20.00
9	41201305100	Chiusura a spinta / Push-pull pressure closing / Druckschließung / Fermeture par pression / Cierre a presión	20.00
9	41301503000V	Pannello inferiore in ghisa / Lower cast iron tile / Unteres Paneel aus Gusseisen / Panneau inférieur en fonte / Panel	62.00

		inferior en arrabio	
10	41411611030V	Supporto pannello inferiore nero / Black lower panel support / Untere Paneel Gestell / Support panneau inferieur noir / Soporte panel inferior negro	46.00
11	6916042	Rivestimento Metal Dark / Metal dark cladding / Verkleidung Metal Dark / Habillage Metal Dark / Revestimiento Metal Dark	150.00
11	6916043	Rivestimento Metal White / Metal White cladding / Verkleidung Metal White / Habillage Metal White / Revestimiento Metal White	150.00
11	6916044	Rivestimento Metal Bordeaux / Metal Bordeaux cladding / Verkleidung Metal Bordeaux / Habillage Metal Bordeaux / Revestimiento Metal Bordeaux	150.00
11	6917014	Rivestimento Metal Silver / Metal Silver cladding / Verkleidung Metal Silver / Habillage Metal Silver / Revestimiento Metal Silver	150.00
11	6916042	Rivestimento Metal Dark / Metal dark cladding / Verkleidung Metal Dark / Habillage Metal Dark / Revestimiento Metal Dark	150.00
11	6916043	Rivestimento Metal White / Metal White cladding / Verkleidung Metal White / Habillage Metal White / Revestimiento Metal White	150.00
11	6916044	Rivestimento Metal Bordeaux / Metal Bordeaux cladding / Verkleidung Metal Bordeaux / Habillage Metal Bordeaux / Revestimiento Metal Bordeaux	150.00
11	6917014	Rivestimento Metal Silver / Metal Silver cladding / Verkleidung Metal Silver / Habillage Metal Silver / Revestimiento Metal Silver	150.00
12	41411599950	Kit serratura ammortizzato / Pressur relief kit / Bausatz Überdruckablauf Brennkammer / Kit deocompression chambre comcusion / Kit decompression camara combustion	46.00
13	41411690230V	Staffa sx supporto fianchi / LH side support bracket / Linke Seitenhaltebügel / Etier droite support coté / Estribo DCHO soporte lado	32.00
13	41411690330V	Staffa dx supporto fianchi / RH side support bracket / Rechte Seitenhaltebügel / Etier gauche support coté / Estribo IZDO soporte lado	28.00
14	41411610132P	Pannello posteriore nero / Black rear panel / Hintere schwarze Rückwand / Panneau postérieur noir / Panel trasero negro	55.00
14	4141161013300	Pannello posteriore nero / Black rear panel / Hintere schwarze Rückwand / Panneau postérieur noir / Panel trasero negro	83.00
15	41411687630P	Schienale nero / Black back panel / Schwarze Rückwand / Dossieret posterieur noir / Panel trasero negro	74.00
15	4141168764100	Schienale nero / Black back panel / Schwarze Rückwand / Dossieret posterieur noir / Panel trasero negro	52.00
16	41411690431P	Supporto pannello comandi / Support control panel / Bedienblendealtebügel / Support de tableau de commandes / Soporte por panel de mandos	32.00
17	41421609242P	Coperchio completo / Complete cover / Kompletter Deckel / Couvercle complet / Tapa completa	103.00
18	41801504700	Guarnizione tenuta serbatoio / Pellet hopper gasket / Pelletbehälter Dichtung / Joint réservoir pellet / Junta depósito pellet	21.00
19	41301603300P	Top ghisa nero / Cast iron top / Schwarze Topplatte aus Guß / Dessus en fonte noir / Top de arrabio negro	112.00
20	41301603201V	Griglia ghisa nera / Black cast iron air grille / Schwarze Luftgitter aus Guß / Grille air en fonte noir / Rejilla aire negra de arrabio	104.00

MCZ GROUP

CLIO HYDRO 23/S

Porta fuoco / Fire door / Feuertür / Porte foyer / Puerta hogar

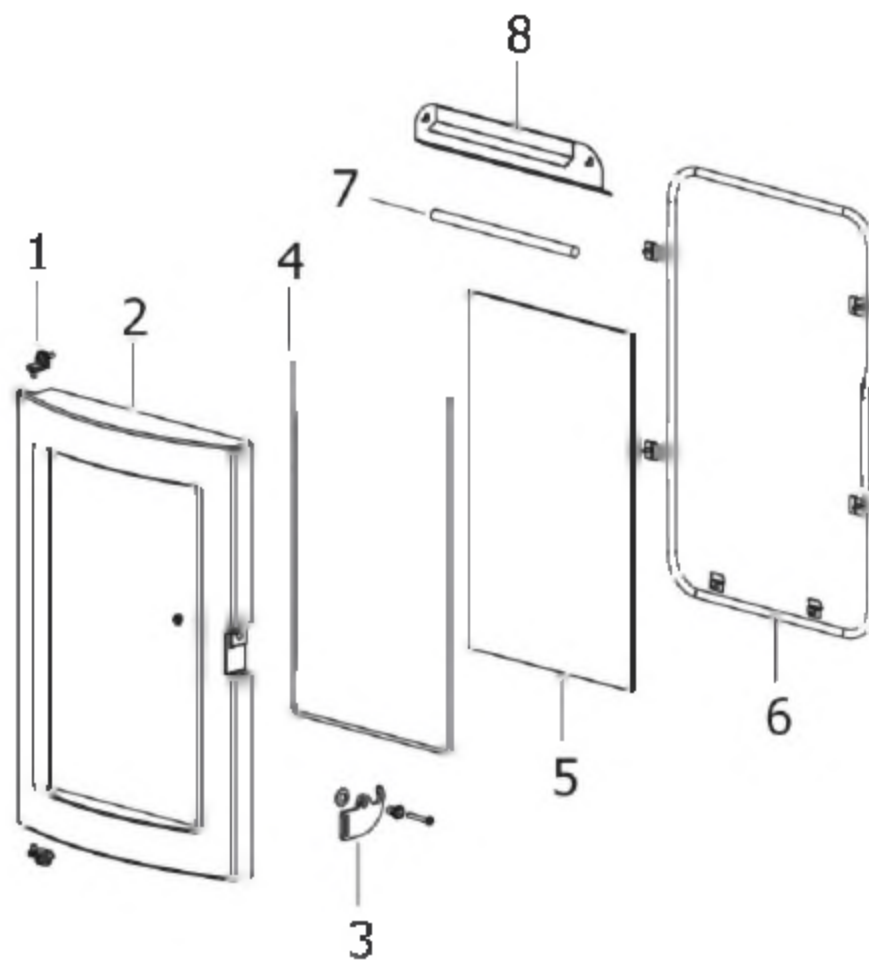

CLIO HYDRO 23/S

Porta fuoco / Fire door / Feuertür / Porte foyer / Puerta hogar

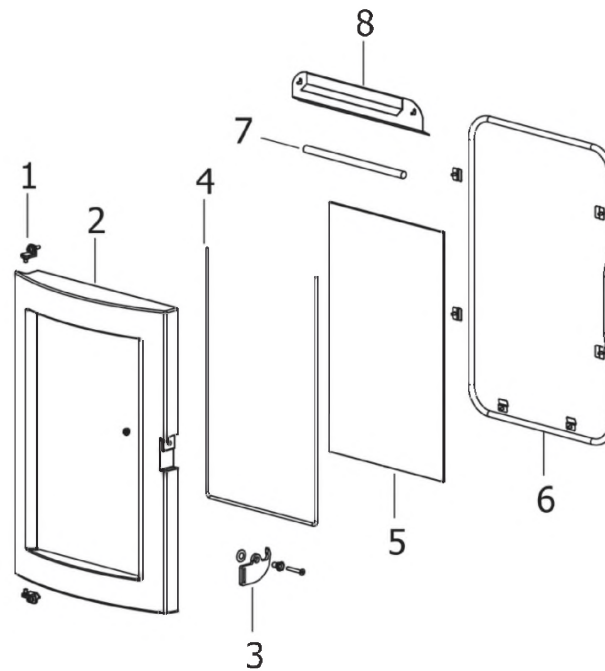

N°	Codice/Code	Descrizioni / Description / Beschreibung / Description / Descripción	Prezzo (€)
1	412008063	Cerniere porta fuoco (2 pz) / Fire door hinge (2pcs) / Scharnier Feuertür (2 Stck) / Charnière porte foyer (2 pcs) / bisagra puerta del hogar (2 pz)	27.00
2	41301400100V	Telaio porta fuoco in ghisa / Cast iron fire door frame / Feuertürrahment aus Guß / Cadre porte foyer en fonte / Armazón puerta hogar de arrabio	145.00
2	41301400101V	Telaio porta fuoco in ghisa / Cast iron fire door frame / Feuertürrahment aus Guß / Cadre porte foyer en fonte / Armazón puerta hogar de arrabio	174.00
2	437016034	Porta focolare / Fireplace door / Feuerstelle Tür / Porte foyer / Puerta hogar	298.00
3	41401424160	Maniglia completa / Complete handle / Kompletter Griff / Poignée complète / Tirador completo	25.00
4	41801603300A	Guarnizione Ø5 5mt / Gasket Ø5 5mt / Dichtung Ø5 5mt / Joint Ø5 5mt / Junta Ø5 5mt	42.00
4	41801603300B	Guarnizione Ø5 50mt / Gasket Ø5 50mt / Dichtung Ø5 50mt / Joint Ø5 50mt / Junta Ø5 50mt	299.00
4	41801603300C	Guarnizione Ø5 5mt + silicone / Gasket Ø5 5mt + silic / Dichtung Ø5 5mt + Silikon / Joint Ø5 5mt + silic / Junta Ø5 5mt	63.00
5	41701400260	Vetroceramico 430x268x4 mm con guarnizione / Glass 430x268x4 mm with gasket / Glasskeramikscheibe 430x268x4 mm mit Dichtung / Vitrocéramique 430x268x4 mm avec joint / Cristal cerámico 430x268x4 mm con junta	127.00
5	41701400261	Vetroceramico 435x268x4 mm con guarnizione / Glass 435x268x4 mm with gasket / Glasskeramikscheibe 435x268x4 mm mit Dichtung / Vitrocéramique 435x268x4 mm avec joint / Cristal cerámico 435x268x4 mm con junta	163.00
6	4120103A	Cordino fibroceramico Ø 10 mm (5 mt.) / Ceramic fibre cord Ø 10 mm (5 m) / Keramikfaserschnur Ø 10 mm (5 m) / Cordon en fibre céramique Ø 10 mm (5 m) / Junta a cuerda de fibra cerámica Ø 10 mm (5 m)	29.00
6	4120103B	Cordino fibroceramico Ø 10 mm (50 mt.) / Ceramic fibre cord Ø 10 mm (50 m) / Keramikfaserschnur Ø 10 mm (50 m) / Cordon en fibre céramique Ø 10 mm (50 m) / Junta a cuerda de fibra cerámica Ø 10 mm (50 m)	167.00
6	41201031	Kit sostituzione cordino (cordino+silicone) Ø 10 mm / Cord replacement kit (cord + silicon) Ø 10 mm / Schnuraustauschsatz (Schnur+Silikon) Ø 10 mm / Kit remplacement cordon (cordon + silicone) Ø 10 mm / Kit sustitución junta a cuerda (junta a cuerda+silicon) Ø 10 mm	43.00
7	41401611030	Deflettore aria vetro / Door deflector / Leitblech der Tür / Déflecteur de la porte / Deflector de la puerta	24.00
8	41411609730V	Profilo tamponazione porta nero / Door filler frame / Türstopfung Profil / Profil tampon porte / Perfil taponado puerta	23.00
8	41411609731V	Profilo tamponazione porta nero / Door filler frame / Türstopfung Profil / Profil tampon porte / Perfil taponado puerta	42.00

MCZ GROUP

CLIO HYDRO 23/S

Componenti interni meccanici ed elettronici / Electronic and mechanic internal parts / Interne mechanische und elektronische Bauteile / Composants internes mécaniques et électroniques / Componentes internos electrónicos y mecánicos

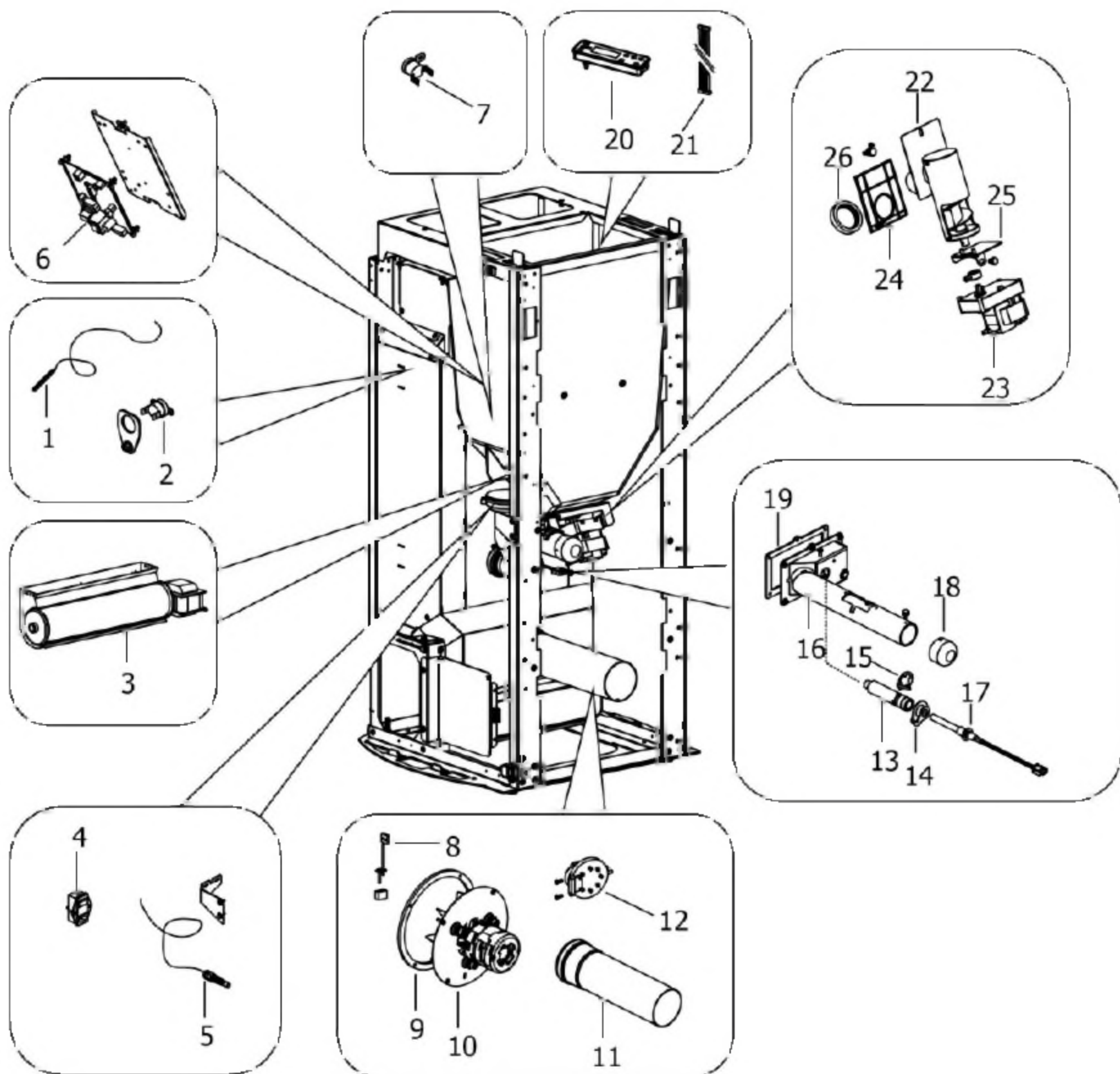

CLIO HYDRO 23/S

Componenti interni meccanici ed elettronici / Electronic and mechanic internal parts / Interne mechanische und elektronische Bauteile / Composants internes mécaniques et électroniques / Componentes internos electrónicos y mecánicos

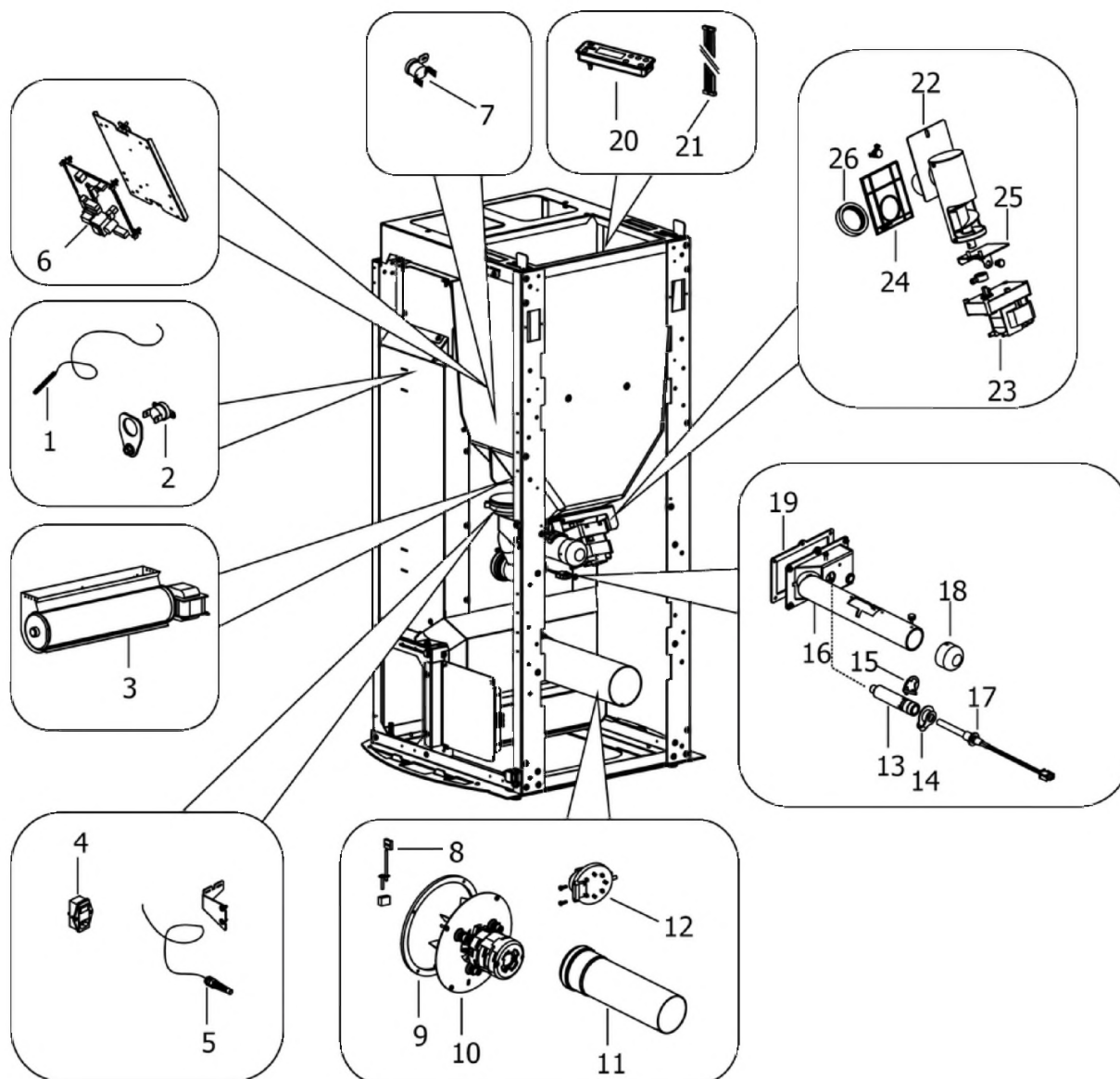

N°	Codice/Code	Descrizioni / Description / Beschreibung / Description / Descripción	Prezzo (€)
1	41451604300	Cablaggio elettrico base / Basic electrical wiring / Elektrische Verkabelung / Câblage électrique / Cableado eléctrico	84.00
2	41450901100	Clickson 95°C / Clickson 95°C / Clickson 95°C / Clickson 95°C / Clickson 95°C	20.00
3	41451000300	Ventilatore scambiatore aria calda / Hot air exchanger fan / Wärmeluftgebläse / Ventilateur échangeur air chaud / Ventilador intercambiador aire caliente	55.00
4	4160193	Pulsante accensione / On/Off button / Zündungstaste / Touche d'allumage / Botón encendido	28.00
5	4160240	Sonda temperatura ambiente / Room temperature sensor / Raumtemperaturfühler / Sonde température ambiance / Sonda temperatura aire	20.00
6	41451200500	Scheda madre completa / Complete mother board / Komplette Hauptplatine / Carte mère complete / Tarjeta madre completa	171.00
6	41451200500B	Scheda madre non programmata / Unprogrammed motherboard / Unprogrammierte Hauptplatine / Carte mère non programmée / Tarjeta madre sin programa	169.00
7	412007004	Clickson 110°C / Clickson 110°C / Clickson 110°C / Clickson 110°C / Clickson 110°C	20.00
8	41451002300	Sonda fumi con flangia / Smoke sensor with flange / Rauchgasfühler mir Flansche / Sonde fumées avec bride / Sonda humos con arandela	31.00

9	41801301500	Guarnizione ventilatore fumi / Smoke exhaust fan gasket / Dichtung Rauchabsauggebläse / Joint Ventilateur aspiration fumées / Junta ventilador aspiración humos	20.00
10	41451600100	Ventilatore fumi senza chiocciola stagno / Air-tight smoke exhausted fan / Luftdicht Rauchgasgebläse / Ventilateur fumées étanche / Ventilador humos hermético	210.00
10	41452009200	Encoder ventilatore / Fan encoder / Lüfter Encoder / Encodeur de ventilateur / Codificador de ventilador	17.00
11	41601601160	Tubp fumi a innesto Ø80 con guarnizione / Smoke pipe Ø 80 with gasket / Rauchrohr Ø 80 mit Dichtung / Tuyau fumées Ø 80 avec joint / Tubo humos Ø 80 con junta	29.00
12	4160482	Pressostato 0,4 mbar / Pressure gauge 0,4 mbar / Druckschalter 0,4 mbar / Pressostat 0,4 mbar / Presostato 0,4 mbar	38.00
13	41601800300	Condotto candeletta / Sparkplug Conduit / Zündkerzenkanal / Conduit Bougie / Conducto Bujía	29.00
14	41801604300	Guarnizione condotto candeletta / Sparkplug conduit gasket / Dichtung Zündkerzenkanal / Joint conduit bougie / Junta conducto bujía	19.00
15	41201601500	Anello arresto candeletta / Sparkplug stop / Zündkerzestopper / Butée bougie / Tope bujía	24.00
16	41421608341V	Scatola aria comburente / Combustion air box / Verbrennungsluft Kasten / Boîte air de combustion / Caja aire de combustion	79.00
17	41451308101	Candeletta 315 Watt / Sparkplug 315 Watt / Zündkerze 315 Watt / Bougie 315 Watt / Bujía 315 Watt	77.00
17	41451308150	Kit 25 candelette 315 Watt / 25 Sparkplugs 315 Watt kit / Bausatz 25 Zündkerzen 315 Watt / Kit 25 Bougies 315 Watt / Kit 25 Bujías 315 Watt	1,637.00
18	41401036100	Filtro antipolvere / Anti-dust filter / Staubschutzfilter / Filtre antipoussière / Filtro de protección polvo	21.00
19	418008027	Guarnizione / Gasket / Dichtung / Joint / Junta	22.00
20	41451701500	Pannello comandi / Control panel / Bedienblende / Tableau de commandes / Panel de mandos	104.00
21	41451201900	Cavo Flat L 1,4 M / Flat cable L 1,4 M / Flat Kable L 1,4 M / Câble Flat L 1,4 M / Cable Flat L 1,4 M	21.00
22	41411800151	Gruppo alimentazione completo / Complete feed screw / Komplette Förderschnecke / Vis sans fin complète / Coclea de carga completa	113.00
23	41450901600	Motoriduttore 3,3 rpm Merkle Korff / Reduction motor 3,3 rpm Merkle Korff / Getriebemotor 3,3 RPM MERKLE KORFF / Motoréducteur 3,3 RPM MERKLE KORFF / Motorreductor 3,3 rpm Merkle Korff	95.00
24	41801600400	Guarnizione gruppo caricamento / Gasket / Dichtung / Joint / Junta	20.00
25	41401606430	Staffa fermo motoriduttore / Reduction motor bracket stop / Getriebemotor Bügelstopper / Butée étrier motoréducteur / Tope zuncho motorreductor	21.00
26	41801702600	Disaccoppiatore mesc. Marrone / Brown disengaging device / Braun Verängungsrohr / Tuyau de découplage maron / Tubo de desvío marron	18.00

MCZ GROUP

CLIO HYDRO 23/S

Gruppo scambiatore / Exchanger group / Austausch Baugruppe / Groupe échangeur / Grupo intercambiador

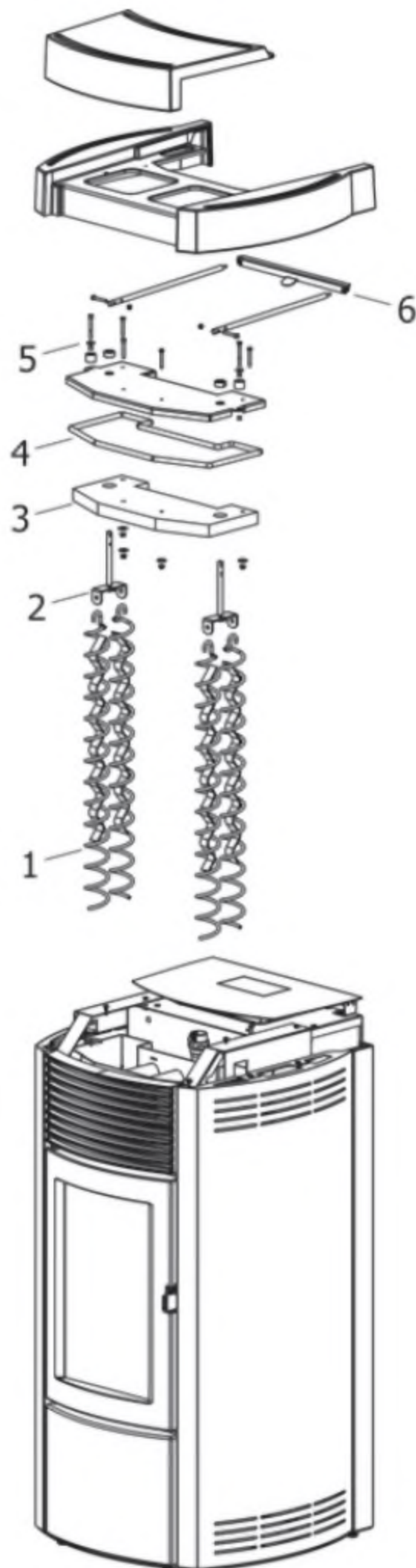

CLIO HYDRO 23/S

Gruppo scambiatore / Exchanger group / Austausch Baugruppe / Groupe échangeur / Grupo intercambiador

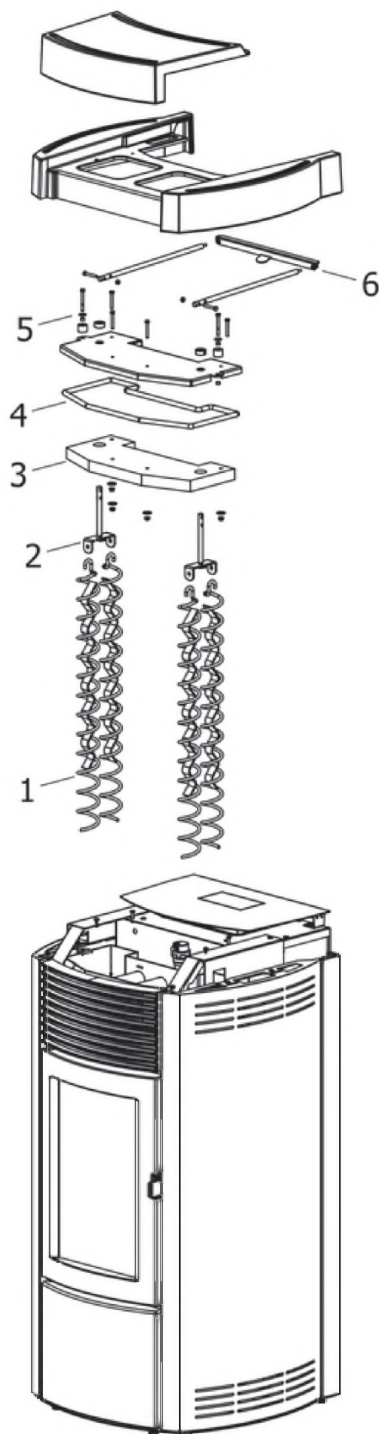

N°	Codice/Code	Descrizioni / Description / Beschreibung / Description / Descripción	Prezzo (€)
1	41400914540	Eliche raschiatore (1 pz.) / Turbulator props (1 pc.) / Propeller des Schabers (1 Teil) / Hélices turbulateur (1 pz.) / Héliche rascador (1 pz.)	41.00
2	41401129341	Staffa sostegno raschiatore Inox / Inox turbulator support bar / Haltebügel des Schabers aus Inox / Etrier support turbulateur en Inox / Zuncho apoyo rascador de Inox	28.00

3	41151600100	Pannello vermiculite coperchio / Vermiculite cover / Deckel aus Vermiculite / Couvercle en vermiculite / Tapa en vermiculite	33.00
4	4120103A	Cordino fibroceramico Ø 10 mm (5 mt.) / Ceramic fibre cord Ø 10 mm (5 m) / Keramikfaserschnur Ø 10 mm (5 m) / Cordon en fibre céramique Ø 10 mm (5 m) / Junta a cuerda de fibra cerámica Ø 10 mm (5 m)	29.00
5	41411608940V	Coperchio struttura caldaia nero / Boiler black cover / Schwarz Kelleldeckel / Couvercle noir chaudière / Tapa negra caldera	70.00
5	41200903300	Trascinatore turbolatori (2 pz.) / Turbolator props puller (2 PC.) / Reinigungsspiralenmitnehmer (2 STCK). / Meneur de turbolateur (2 Pc.) / Arrebatador hélice rascador (2 pz).	25.00
5	41801499550	Kit scarico sovrappressione camera di combustione (pz.2) / Pressure relief kit (Pcs.2) / Bausatz überdruckablauf brennkammer (Stck.2) / Kit decompression chambre combustion (Pcs.2) / Kit descompresion camara combustion (Pcs.2)	25.00
6	41401605430	Traversa leve movimentazione turbolatori / Tturbolator handling crossbeam / Turbolatorstange Träger / Traverse tige turbolateur / Traversa asta rascador	56.00

MCZ GROUP

CLIO HYDRO 23/S

Componenti interni idraulici CON kit acqua sanitaria / Internal plumbing components WITH domestic water kit / Interne hydraulische Bauteile MIT Brauchwassersatz / Composants hydrauliques internes AVEC kit eau sanitaire / Componentes internos hidráulicos CON kit de agua sanitaria

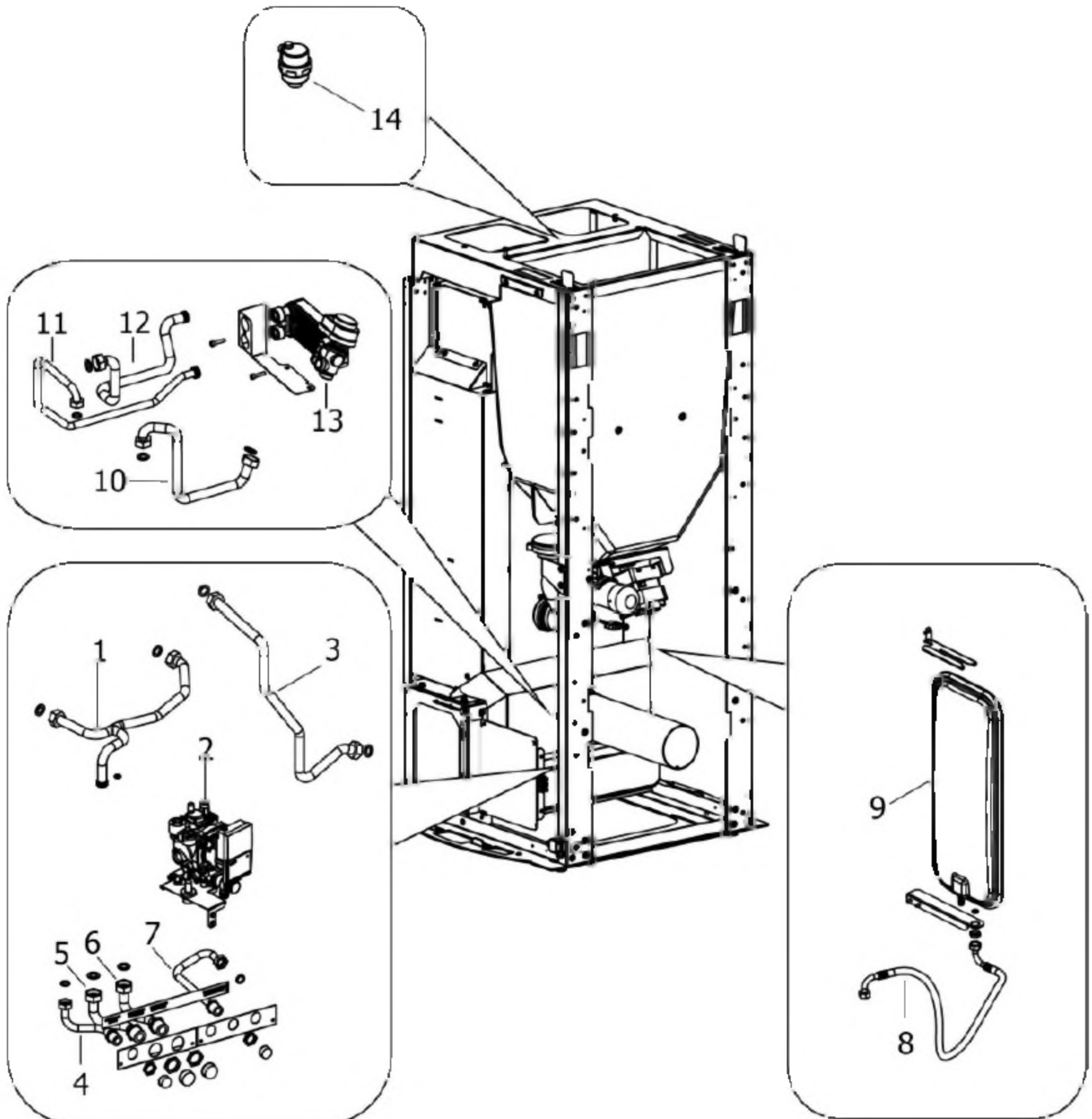

CLIO HYDRO 23/S

Componenti interni idraulici CON kit acqua sanitaria / Internal plumbing components WITH domestic water kit / Interne hydraulische Bauteile MIT Brauchwassersatz / Composants hydrauliques internes AVEC kit eau sanitaire / Componentes internos hidráulicos CON kit de agua sanitaria

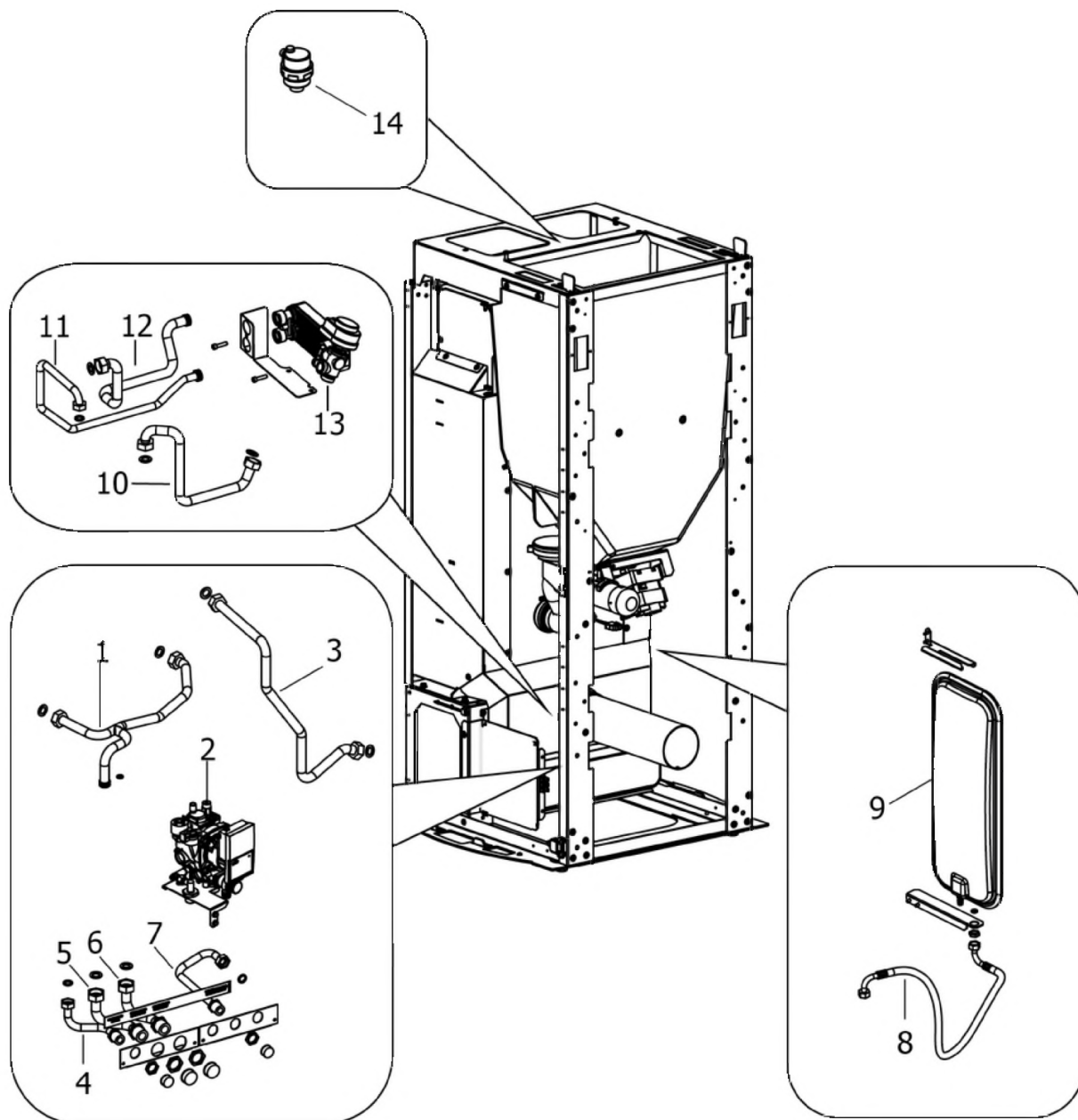

N°	Codice/Code	Descrizioni / Description / Beschreibung / Description / Descripción	Prezzo (€)
1	41501600300	Tubo circolazione caldaia / Boiler circulation tube / Rohr für Kesselumwälzung / Tuyau de circulation chaudière / Tubo de circulación caldera	58.00
1	4120790	Kit guarnizioni impianto idraulico / Hydraulic system gasket kit / Dichtungsbausatz für Hydraulikanlage / Kit de joints pour l'installation hydraulique / Kit de juntas de la instalacion de fontaneria	21.00
2	41501601150	Gruppo idraulico - con produzione acqua sanitaria - con circolatore alta efficienza (Wilo Para) / Hydraulic unit - with domestic hot water production - with high efficiency circulation pump (Wilo Para) / Hydraulikeinheit - mit Brauchwarmwasser Herstellung - mit Hochleistungs-Zirkulator (Wilo Para) / Unité hydraulique - avec production eau chaude sanitaire - avec circulateur à haut rendement (Wilo Para) / Unidad hidráulica - con producción agua caliente sanitaria - con bomba alto rendimiento (Wilo Para)	-
2	41501700900	Pompa / Pump / Pumpe / Pompe / Bomba	278.00
2	41501601151	Gruppo idraulico - con produzione acqua sanitaria - con circolatore alta efficienza (Wilo Para) / Hydraulic unit - with domestic hot water production - with high efficiency circulation pump (Wilo Para) / Hydraulikeinheit - mit Brauchwarmwasser Herstellung - mit Hochleistungs-Zirkulator (Wilo Para) / Unité hydraulique - avec production eau	383.00

		chaude sanitaire - avec circulateur à haut rendement (Wilo Para) / Unidad hidráulica - con producción agua caliente sanitaria - con bomba alto rendimiento (Wilo Para)	
2	41501700901	Pompa / Pump / Pumpe / Pompe / Bomba	284.00
2	41451108000	Pressostato di minima H2O / Pressur switch H2O / Druckwächter H2O / Pressostat H2O / Presostato H2O	31.00
2	41501103300	Valvola di sicurezza 3 Bar / Maximum pressure valve 3 Bar / Sicherheitsventil 3 Bar / Soupape de pression maximale 3 Bar / Válvula máxima presión 3 Bar	32.00
2	41501700700	Flussostato / Flow switch / Strömungswächter / Fluxostat / Flujustato	32.00
3	41501601400	Tubo mandata caldaia/scambiatore / Boiler/exchanger water delivery tube / Vorlaufrohr Wasser-Kessel/Wärmetauscher / Tuyau de refoulement eau-chaudière/échangeur / Tubo de envío agua-caldera/intercambiador	33.00
3	4120790	Kit guarnizioni impianto idraulico / Hydraulic system gasket kit / Dichtungsbausatz für Hydraulikanlage / Kit de joints pour l'installation hydraulique / Kit de juntas de la instalación de fontanería	21.00
4	41501600400	Tubo di carico caldaia / Boiler loading tube / Rohr für Kesseleinfüllung / Tuyau de chargement chaudière / Tubo de carga caldera	35.00
4	4120790	Kit guarnizioni impianto idraulico / Hydraulic system gasket kit / Dichtungsbausatz für Hydraulikanlage / Kit de joints pour l'installation hydraulique / Kit de juntas de la instalación de fontanería	21.00
5	41501600500	Tubo ritorno impianto / Return tube / Rücklaufrohr / Tuyau retour / Tubo de regreso	38.00
5	4120790	Kit guarnizioni impianto idraulico / Hydraulic system gasket kit / Dichtungsbausatz für Hydraulikanlage / Kit de joints pour l'installation hydraulique / Kit de juntas de la instalación de fontanería	21.00
6	41501600700	Raccordo mandata impianto / Delivery tube connection / Vorlaufrohr Verbindung / Raccord tuyau refoulement / Raccor tubo de envío	38.00
6	4120790	Kit guarnizioni impianto idraulico / Hydraulic system gasket kit / Dichtungsbausatz für Hydraulikanlage / Kit de joints pour l'installation hydraulique / Kit de juntas de la instalación de fontanería	21.00
7	41501601700	Tubo uscita sanitaria calda / Domestic hot water outlet tube / Warmes Sanitärwasser Ausgangrohr / Tuyau de sortie eau sanitaire chaud / Tubo de salida agua sanitaria caliente	27.00
7	4120790	Kit guarnizioni impianto idraulico / Hydraulic system gasket kit / Dichtungsbausatz für Hydraulikanlage / Kit de joints pour l'installation hydraulique / Kit de juntas de la instalación de fontanería	21.00
8	41501601000	Tubo flessibile L.600 / Flexible tube L.600 / Flexibles Rohr L.600 / Tuyau flexible L.600 / Tubo flexible L.600	29.00
8	4120790	Kit guarnizioni impianto idraulico / Hydraulic system gasket kit / Dichtungsbausatz für Hydraulikanlage / Kit de joints pour l'installation hydraulique / Kit de juntas de la instalación de fontanería	21.00
9	4120775	Vaso espansione (6 l) / Expansion vessel (6 l) / Expansionsgefäß (6 l) / Vase d'expansion (6 l) / Vaso de expansion (6 l)	75.00
10	41501601300	Tubo scambiatore/mandata riscaldamento / Exchanger/Heating water delivery tube / Rohr Wärmetauscher/Heizungsvorlaufrohr / Tuyau échangeur/refoulement eau chauffage / Tubo intercambiador/envío de agua calentamiento	30.00
10	4120790	Kit guarnizioni impianto idraulico / Hydraulic system gasket kit / Dichtungsbausatz für Hydraulikanlage / Kit de joints pour l'installation hydraulique / Kit de juntas de la instalación de fontanería	21.00
11	41501601600	Tubo ingresso sanitaria fredda / Domestic cold water inlet tube / Kaltes Sanitärwasser Eingangrohr / Tuyau d'entrée eau sanitaire froid / Tubo de entrada agua sanitaria fría	36.00
11	4120790	Kit guarnizioni impianto idraulico / Hydraulic system gasket kit / Dichtungsbausatz für Hydraulikanlage / Kit de joints pour l'installation hydraulique / Kit de juntas de la instalación de fontanería	21.00
12	41501601500	Tubo ritorno impianto/scambiatore / Return tube system/exchanger / Rücklaufrohr Anlage/Wärmetauscher / Tuyau retour système/échangeur / Tubo de regreso sistema/intercambiador	30.00
12	4120790	Kit guarnizioni impianto idraulico / Hydraulic system gasket kit / Dichtungsbausatz für Hydraulikanlage / Kit de joints pour l'installation hydraulique / Kit de juntas de la instalación de fontanería	21.00
13	41501700200	Scambiatore 14 piastre / Exchanger 14 plates / Wärmetauscher 14 Platten / Échangeur 14 plaques / Intercambiador 14 placas	81.00
13	41501700300	Valvola 3 vie attacco rapido / 3-way valve quick connection / Dreiwegeventil schnelle Verbindung / Soupape à 3 voies connexion rapide / Válvula a 3 vías conexión rápida	133.00
13	41501801050	kit scambiatore con valvola a 3 vie / Kit exchanger/3 way valve / Kit Austausch/Dreiwegeventil / Kit échangeur/Soupape 3 voies / Kit intercambiador/Valvula a 3 vías	280.00
14	4120779	Valvola di sfianto / Vent valve / Entlüftungsventil / Soupape de dégagement / Válvula respiradero	26.00