

## TULIP - EASY CONNECT

Componenti Struttura Esterna / External structure components / Bauteile Aussenkorpus / Composants structure externe / Componentes estructura externa

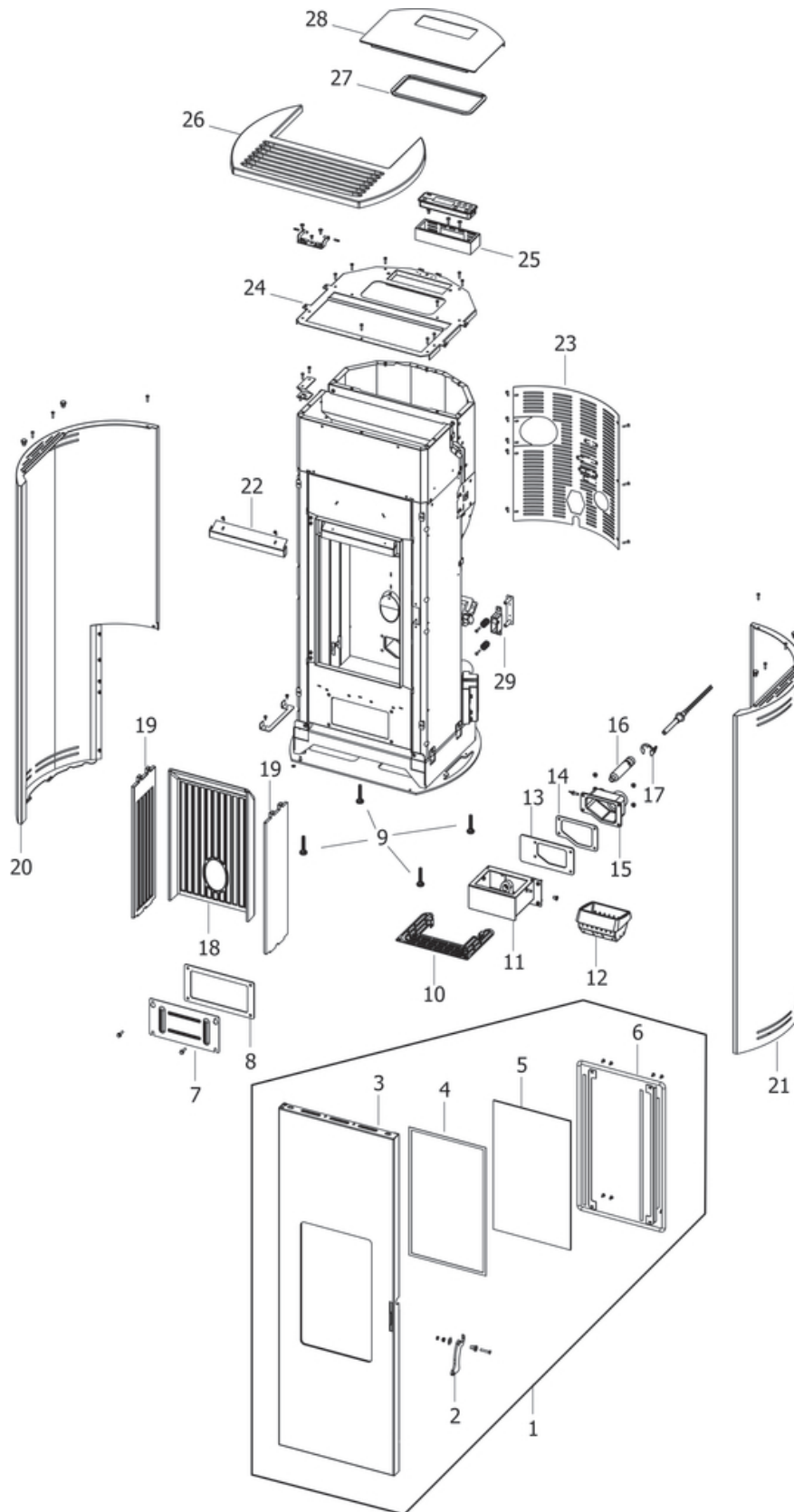

N°	Codice/Code	Descrizioni / Description / Beschreibung / Description / Descripción	Prezzo (€)
1	437016089	Porta completa / Complete door / Komplette Tür / Porte complète / Puerta completa	395.00
2	41400911160	Maniglia completa / Complete handle / Kompletter Griff / Poignée complète / Tirador completo	25.00
2	41401424160	Maniglia completa / Complete handle / Kompletter Griff / Poignée complète / Tirador completo	25.00
3	41421603240P	Telaio porta fuoco / Fire door frame / Feuertürrahmen / Cadre porte foyer / Armazón puerta de arrabio	324.00
3	41421603241P	Telaio porta fuoco / Fire door frame / Feuertürrahmen / Cadre porte foyer / Armazón puerta de arrabio	301.00
4	4120573A	Guarnizione a nastro 8 mm (5 mt.) per porta / Door strip gasket 8 mm (5 m) / Türbanddichtung 8 mm (5 m) / Joint ruban 8 mm (5 m) pour porte / Guarnición de cinta para puerta 8 mm (5 m)	32.00
4	4120573B	Guarnizione a nastro 8 mm (50 mt.) per porta / Door strip gasket 8 mm (50 m) / Türbanddichtung 8 mm (50 m) / Joint ruban 8 mm (50 m) pour porte / Guarnición de cinta para puerta 8 mm (50 m)	162.00
5	41701600300	Vetroceramico porta ghisa / Cast iron door glass / Glaskeramikscheibe Tür aus Gusseise / Vitrocéremique porte en fonte / Cristal cerámico puerta en arrabio	79.00
6	4120104A	Cordino fibroceramico Ø 12 mm (5 mt.) / Ceramic fibre cord Ø 12 mm (5 m.) / Keramikfaserschnur Ø 12 mm (5 m) / Cordon en fibre céramique Ø 12 mm (5 m) / Junta a cuerda de fibra cerámica Ø 12 mm (5 m)	36.00
6	4120104B	Cordino fibroceramico Ø 12 mm (50 mt.) / Ceramic fibre cord Ø 12 mm (50 m.) / Keramikfaserschnur Ø 12 mm (50 m) / Cordon en fibre céramique Ø 12 mm (50 m) / Junta a cuerda de fibra cerámica Ø 10 mm (52 m)	210.00
6	41201041	Kit sostituzione cordino (cordino+silicone) Ø 12 mm / Cord replacement kit (cord + silicon) Ø 12 mm / Schnuraustauschsetz (Schnur+Silikon) Ø 12 mm / Kit remplacement cordon (cordon + silicone) Ø 12 mm / Kit sustitución junta a cuerda (junta a cuerda+silicón) Ø 12 mm	50.00
7	41401339610	Tappo ispezione vano fumi / Smoke compartment inspection plug / Inspektionsdeckel Rauchabzug / Clapet inspection compartiment fumées / Tapón inspección compartimento humos	21.00
8	41800900600	Guarnizione / Gasket / Dichtung / Joint / Junta	21.00
8	41801599750	Kit 50 guarnizioni / Kit 50 gaskets / Bausatz 50 Dichtungen / Kit 50 joints / Kit 50 juntas	840.00
9	41200906660	Piedini di appoggio (4 pz.) / Support feet (4 pcs.) / Einstellfüße (4 Stck.) / Vérins d'appui (4 p.es) / Pies de apoyo (4 piezas)	19.00
10	41411634830V	Griglia focolare / Fire Box Grille / Feuerstellenrost / Grille Foyer / Rejilla Hogar	29.00
11	41402071340	Tasca braciere / Combustion pot container / Brenntopfkasten / Récipient brasero / Contenidor brasero	87.00
12	41301502400V	Braciere ghisa / Cast iron grate / Brenntopf aus Gusseisen / Brasero en fonte / Brasero en arrabio	51.00
13	41801601500	Guarnizione tasca braciere / Combustion pot container gasket / Brenntopfkasten Dichtung / Joint récipient brasero / Junta contenidor brasero	18.00
14	41801602300	Guarnizione codolo / Gasket / Dichtung / Joint / Junta	19.00
15	41311803500	Codolo / Tool chuck / Einspannschaft / Outil d'emmanchement / Mango	44.00
16	41601601000	Condotto candeletta / Sparkplug Conduit / Zündkerzenkanal / Conduit Bougie / Conducto Bujía	27.00
17	41201601500	Anello arresto candeletta / Sparkplug stop / Zündkerzestopper / Butée bougie / Tope bujía	24.00
18	41301502800V	Schiena ghisa nera / Cast iron back / Rückwand aus Gusseisen / Dossieret en fonte / Parte trasera en arrabio	72.00
19	41301502700V	Fianco ghisa / Cast iron side / Seite aus Guß / Côté en fonte / Placa lateral de arrabio	50.00
19	41301502700V	Fianco ghisa / Cast iron side / Seite aus Guß / Côté en fonte / Placa lateral de arrabio	50.00
20	41411604860P	Fianco sinistro completo Silver / Complete L. side Silver / Komplet Li. Seite Silver / Côte G. complet Silver / Lateral completo IZDO palta	239.00
20	41411604960P	Fianco sinistro completo Avorio / Complete L. side Ivory / Komplet Li. Seite Elfenbein / Côte G. complet Ivoire / Lateral completo IZDO marfil	207.00
20	41411605060P	Fianco sinistro completo Bordeaux / Complete L. side Bordeaux / Komplet Li. Seite Bordeaux / Côte G. complet Bordeaux / Laterla completo IZDO burdeos	215.00
21	41411605260P	Fianco destro completo Silver / Complete R. side Silver / Komplet Re. Seite Silver / Côte D. complet Silver / Lateral completo DCHO palta	239.00
21	41411605360P	Fianco destro completo Avorio / Complete R. side Ivory / Komplet Re. Seite Elfenbein / Côte D. complet Ivoire / Lateral completo DCHO marfil	202.00
21	41411605460P	Fianco destro completo Bordeaux / Complete R. side Bordeaux / Komplet Re. Seite Bordeaux / Côte D. complet Bordeaux / Laterla completo DCHO burdeos	215.00
22	41411615430V	Deflettore aria / Air deflector / Luftleitblech / Déflecteur aire / Deflector aire	26.00
23	41411645330P	Pannello posteriore ispezione Silver / Silver rear inspection panel / Hintere Silver Inspektionsrückwand / Panneau inspection postérieur Silver / Panel inspección trasero Silver	73.00
23	1010	Non disponibile / Not available / Nicht verfügbar / Non disponible / No disponible	-
23	41411645530P	Pannello posteriore ispezione Bordeaux / Bordeaux rear inspection panel / Hintere Bordeaux Inspektionsrückwand / Panneau inspection postérieur Bordeaux / Panel inspección trasero Bordeaux	73.00
24	41411635840V	Supporto top completo / Top support / Deckelhaltebügel / Support du dessus / Soporite top	85.00
25	41411634930P	Supporto pannello comandi / Display stand / Fassung für Bedienblende / Support panneau des commandes / Soporite panel de mandos	28.00

<b>26</b>	<b>41301600100P</b>	Top ghisa nero / Cast iron top / Abdeckplatte aus Gusseisen / Dessus en fonte / Top de arrabio	<b>95.00</b>
<b>27</b>	<b>41801601400</b>	Guarnizione coperchio serbatoio / Pellet hopper cover gasket / Deckel Pelletbehälter Dichtung / Joint couvercle réservoir pellet / Junta tapa depósito pellet	<b>21.00</b>
<b>28</b>	<b>41421603340P</b>	Coperchio completo nero / Complete black cover / Schwarz komplet Deckel / Couvercle Complét noir / Tapa Completa negra	<b>95.00</b>
<b>28</b>	<b>41801657900</b>	Magneti (pz.2) / Magnet (pcs.2) / Magnet (stk. 2) / Aimant (pcs.2) / Imán (pz.2)	<b>22.00</b>
<b>29</b>	<b>41411599950</b>	Kit serratura ammortizzato / Pressur relief kit / Bausatz Überdruckablauf Brennkammer / Kit decompression chambre combustion / Kit decompression cámara combustion	<b>46.00</b>

## TULIP - EASY CONNECT

Componenti interni meccanici ed elettronici / Electronic and mechanic internal parts / Interne mechanische und elektronische Bauteile / Composants internes mécaniques et électroniques / Componentes internos electrónicos y mecánicos

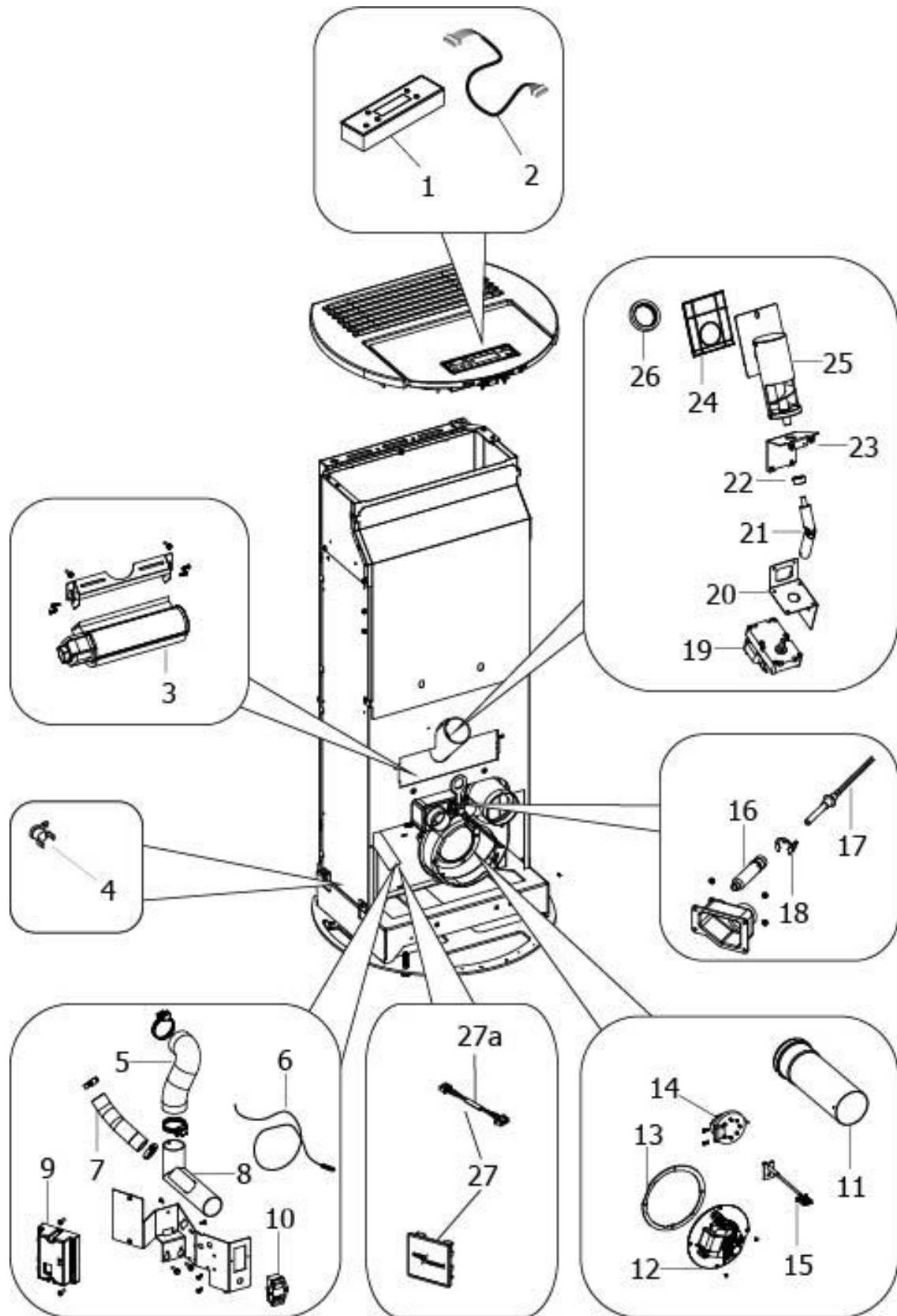

N°	Codice/Code	Descrizioni / Description / Beschreibung / Description / Descripcion	Prezzo (€)
1	41451200600	Pannello comandi / Control panel / Bedienblende / Panneau de commande / Panel de mandos	102.00
2	41451201900	Cavo Flat L 1,4 M / Flat cable L 1,4 M / Flat Kable L 1,4 M / Câble Flat L 1,4 M / Cable Flat L 1,4 M	21.00
2	41451601400	Cablaggio / Wiring / Verkabelung / Câblage / Cableado	34.00
3	41451600800	Ventilatore aria / Air fan / Luftgebläse / Ventilateur air / Ventilador aire	76.00
4	412007004	Clickson 110°C / Clickson 110°C / Clickson 110°C / Clickson 110°C / Clickson 110°C	20.00
5	41801601700	Tubo aspirazione camera combustione / Combustion chamber aspiration tube / Verbrennungskammer Förderrohr / Tuyau aspiration air chambre de combustion / Tubo aspiración aire cámara de combustión	28.00
6	41451405600	Sonda ambiente / Room temperature sensor / Raumtemperaturfühler / Sonde température ambiance / Sonda temperatura ambiente	19.00
7	41801601900	Tubo aspirazione pulizia vetro / Inlet pipe for cleaning glass air / Glassreinigungs Lufteingangsrohr / Tuyau entrée pour l'aire de nettoyage du vitre / Tubo entrada por l'aire de limpieza vidrio	62.00
8	41601602360	Tubo aspirazione completo / Complete air inlet pipe / Komplet Lufteingangsrohr / Tuyau entrée d'air complet / Tubo entrada aire completo	66.00
9	41452002300	Scheda madre neutra / Unprogrammed motherboard / Unprogrammierte Hauptplatine / Carte mère non programmée / Tarjeta madre sin programa	97.00
9	41452002300A	Scheda con firmware W001_F02 OYSTER 01 / Motherboard with firmware W001_F01 OYSTER 01 / Hauptplatine mit Firmware W001_F01 OYSTER 01 / Carte mère avec Firmware W001_F01 OYSTER 01 / Tarjeta madre con Firmware W001_F01 OYSTER 01	97.00
9	41451601400	Cablaggio / Wiring / Verkabelung / Câblage / Cableado	34.00
10	41451104100	Presca con fusibile / Socket with fuse / Steckdose mit Sicherung / Prise avec fusible / Toma con fusible	14.00
11	41601603000	Tubo Ø8 L.25 con guarnizione / Pipe Ø8 L.25 with gasket / Rohr Ø8 L.14 mit Dichtung / Tuyau Ø8 L.25 avec joint / Tubo Ø8 L.25 con guarnición	30.00
12	41451503200	Ventilatore fumi stagno / Air-tight smoke exhausted fan / Luftdichtes Rauchgasgebläse / Ventilateur fumées étanche / Ventilador humos hermético	82.00
13	41801600800	Guarnizione ventilatore fumi / Smoke exhaust fan gasket / Dichtung Rauchabsauggebläse / Joint Ventilateur aspiration fumées / Junta ventilador aspiración humos	22.00
14	41451003700	Pressostato / Pressure switch / Druckschalter / Pressostat / Presostato	40.00
15	41451401300	Sonda fumi con flangia / Smoke sensor with flange / Rauchsonde mit Flansche / Sonde fumées avec bride / Sonda humos con brida	30.00
16	41601601000	Condotto candeletta / Sparkplug Conduit / Zündkerzenkanal / Conduit Bougie / Conducto Bujía	27.00
17	41451308101	Candeletta 315 Watt / Sparkplug 315 Watt / Zündkerze 315 Watt / Bougie 315 Watt / Bujía 315 Watt	77.00
18	41201601500	Anello arresto candeletta / Sparkplug stop / Zündkerzestopper / Butée bougie / Tope bujía	24.00
19	41451503100	Motoriduttore 2rpm / Gear motor 2rpm / Getriebemotor 2rpm / Motoréducteur 2rpm / Motorreductor 2rpm	102.00
20	41401609830	Supporto motoriduttore / Reduction motor support / Schneckenmotor Gestell / Support motoréducteur / Soporte motoreductor	20.00
21	41801604200	Cardano / Cardan / Kardan / Cardan / Cardán	49.00
22	4120398	Connettore motoriduttore-coclea / Reduction motor-feed screw connector / Verbindung Getriebemotor-Schnecke / Connecteur motoréducteur-vis sans fin / Conector motorreductor-cóclea	22.00
23	41401612630	Base coclea pellet / Feed screw base / Untergestell der Förderschnecke / Base de la vis sans fin / Base de la cóclea	26.00
24	41802000300	Guarnizione / Gasket / Dichtung / Joint / Junta	11.00
25	41402002050	Gruppo alimentazione / Complete feed screw / Komplette Förderschnecke / Vis sans fin complète / Coclea de carga completa	98.00
26	41801702600	Disaccoppiatore mesc. Marrone / Brown disengaging device / Braun Verängungsrohr / Tuyau de découplage maron / Tubo de desvío marron	18.00
27	4020003	Wi-Fi Easy Connect / Wi-Fi Easy Connect / Wi-Fi Easy Connect / Wi-Fi Easy Connect / Wi-Fi Easy Connect	67.00
27a	41452002500	Cavo flat / Flat cable / Flat-Kabel / Cable flat / Flat cable	13.00