

MCZ GROUP

KASAI

Componenti / Components / Bauteile / Composants / Componentes

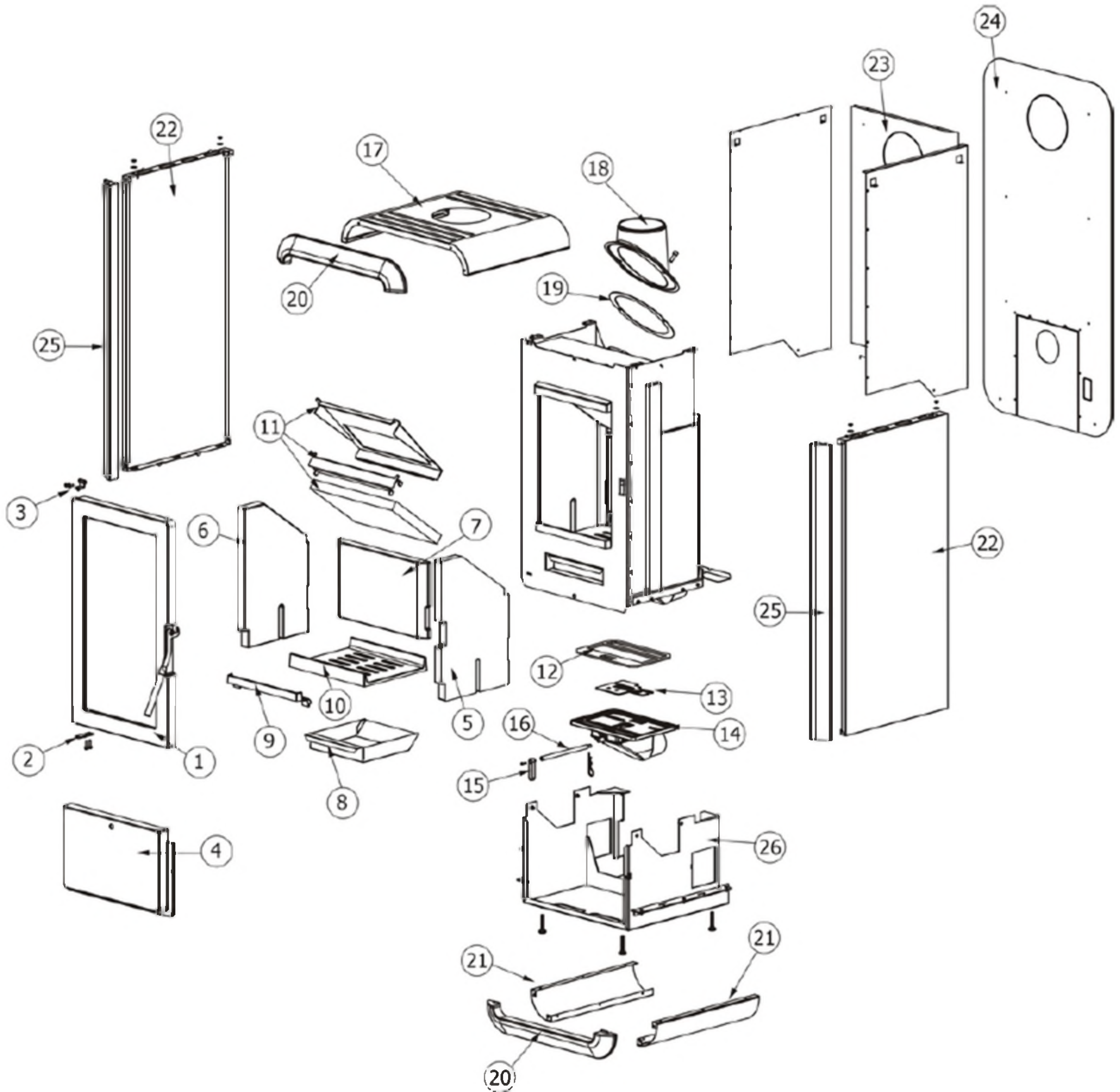

KASAI

Componenti / Components / Bautelie / Composants / Componentes

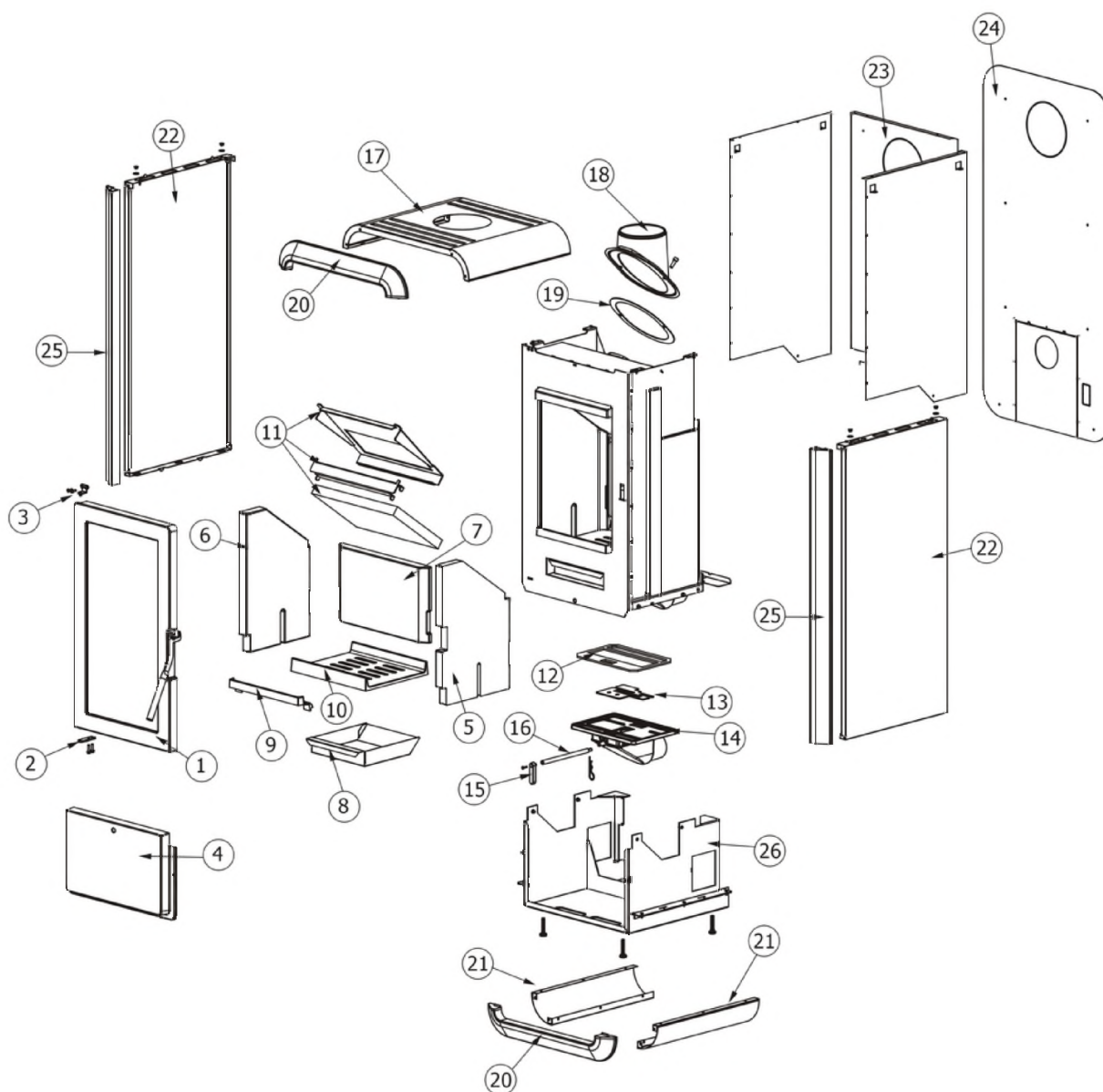

N°	Codice/Code	Descrizioni / Description / Beschreibung / Description / Descripción	Prezzo (€)
1	41301004850	Porta finita completa / Complete finished door / Komplette Tür / Porte finie complète / Puerta completa	463.00
2	41401110410	Cerniera inferiore / Lower hinge / Unteres Scharnier / Charnière inférieure / Bisagra inferior	19.00
3	41401110540	Cerniera superiore / Upper hinge / Oberes und Scharnier / Charnière supérieure / Bisagra superior	25.00
4	41301004900	Tamponazione inferiore nera / Black lower filler / Untere schwarze Stopfung / Plaque inférieure noire / Tapa inferior negra	98.00
5	41151000900	Fianco DX in Alutec® / Alutec® R. side / RE. Aussenseite aus Alutec® / Côté droite en Alutec® / Lateral DCHO en Alutec®	57.00
6	41151001000	Fianco SX in Alutec® / Alutec® left side / LI. Aussenseite aus Alutec® / Côté gauche en Alutec® / Lateral IZDO en Alutec®	57.00
7	41151001100	Schiena in Alutec® / Alutec® back / Rückwand aus Alutec® / Fond en Alutec® / Parte trasera en Alutec®	52.00
8	41401109340	Cassetto cenere / Ash drawer / Aschenkasten / Tiroir à cendres / Cajón ceniza	42.00
9	41301004000	Paraceppi-Portalegna in ghisa / Cast iron log guard-wood rack / Holzscheithalterung aus Gusseisen / Grille de foyer pare-bûches en fonte / Chapa frontal parabrasa en arrabio	55.00
10	41301004400	Piano fuoco in ghisa / Cast iron fire bed / Brennebene aus Gusseisen / Plaque foyère en fonte / Piso del hogar en arrabio	106.00

11	41401109430	Defflettore fumi completo / Smoke deflector / Rauchleitblech / Déflecteur fumées complet / Deflector humos completo	107.00
12	41801003400	Guarnizione / Gasket / Dichtung / Joint / Junta	20.00
13	41401109660	Serranda regolazione aria comburente / Combustion air damper control / Verbrennungsluftregelungsklappe / Registre de contrôle l'air de combustion / Compuerta de regulación aire de combustión	21.00
14	41801100450	Gruppo regolazione aria comburente / Inlet air regulation block / Verbrennungsluftregelungsbaugruppe / Groupe de regulation entrée air comburente / Grupo regulación aire de combustión	196.00
15	41311000260	Leva registro aria comburente / Combustion air adjustment lever / Einstellhebel Verbrennungsluft / Levriere registre air comburant / Palanca regulación aire comburente	18.00
16	41201100260	Asta regolazione aria comburente / Inlet air regulation shaft / Verbrennungsluft Regelungsstange / Tige de regulation air comburant / Asta regulación aire comburente	23.00
17	6911007	Rivestimento completo Black metal / Complete Black metal cladding / Komplette Verkleidung Black metal / Habillage complète Black metal / Revestimiento completo Black metal	0.00
17	6911008	Rivestimento completo Aluminium metal / Complete Aluminium metal cladding / Komplette Verkleidung Aluminium metal / Habillage complète Aluminium metal / Revestimiento completo Aluminium metal	460.00
18	41301004100	Tubo uscita fumi in ghisa / Cast iron smoke outlet / Gussseisen Rauchabzugrohr / Tuyau sortie des fumées en fonte / Tubo salida humos en arrabio	66.00
19	41801003300	Guarnizione / Gasket / Dichtung / Joint / Junta	20.00
20	41311100461	Profilo stondato inferiore e superiore / Upper/Lower rounded profile / Oberes/unteres abgerundetet Profil / Profil srrondé supérieur/inferieur / Perfil redondeado superior/inferior	52.00
20	41311100461	Profilo stondato inferiore e superiore / Upper/Lower rounded profile / Oberes/unteres abgerundetet Profil / Profil srrondé supérieur/inferieur / Perfil redondeado superior/inferior	52.00
21	41401112160	Profilo inferiore stondato DX-SX / LE.RI. lower rounded profile / Re./Li.unteres abgerundetet Profil / Profil arrondé inferieur D./G. / Perfil redondeado inferior DCHO/IZDO	59.00
22	6911007	Rivestimento completo Black metal / Complete Black metal cladding / Komplette Verkleidung Black metal / Habillage complète Black metal / Revestimiento completo Black metal	0.00
22	6911008	Rivestimento completo Aluminium metal / Complete Aluminium metal cladding / Komplette Verkleidung Aluminium metal / Habillage complète Aluminium metal / Revestimiento completo Aluminium metal	460.00
22	6911007	Rivestimento completo Black metal / Complete Black metal cladding / Komplette Verkleidung Black metal / Habillage complète Black metal / Revestimiento completo Black metal	0.00
22	6911008	Rivestimento completo Aluminium metal / Complete Aluminium metal cladding / Komplette Verkleidung Aluminium metal / Habillage complète Aluminium metal / Revestimiento completo Aluminium metal	460.00
23	41401117830	Schiena posteriore / External back / Hintere Rückwand / Dosseret postérieur / Parte trasera	73.00
24	41401110260	Schiena posteriore in acciaio nero verniciato / Black painted steel back / Hintere Rückwand aus Stahl Schwarz lackiert / Dosseret postérieur en acier laqué noir / Parte trasera en acero negro barnizado	61.00
25	41201007360	Montante anteriore / Frontal vertical rod / Vordere Montageleiste / Montant antérieur / Montante anterior	62.00
25	41201007360	Montante anteriore / Frontal vertical rod / Vordere Montageleiste / Montant antérieur / Montante anterior	62.00
26	41401109840	Basamento / Base / Basis / Base / Base	104.00

MCZ GROUP

KASAI

Porta fuoco / Fire door / Feuertür / Porte foyer / Puerta hogar

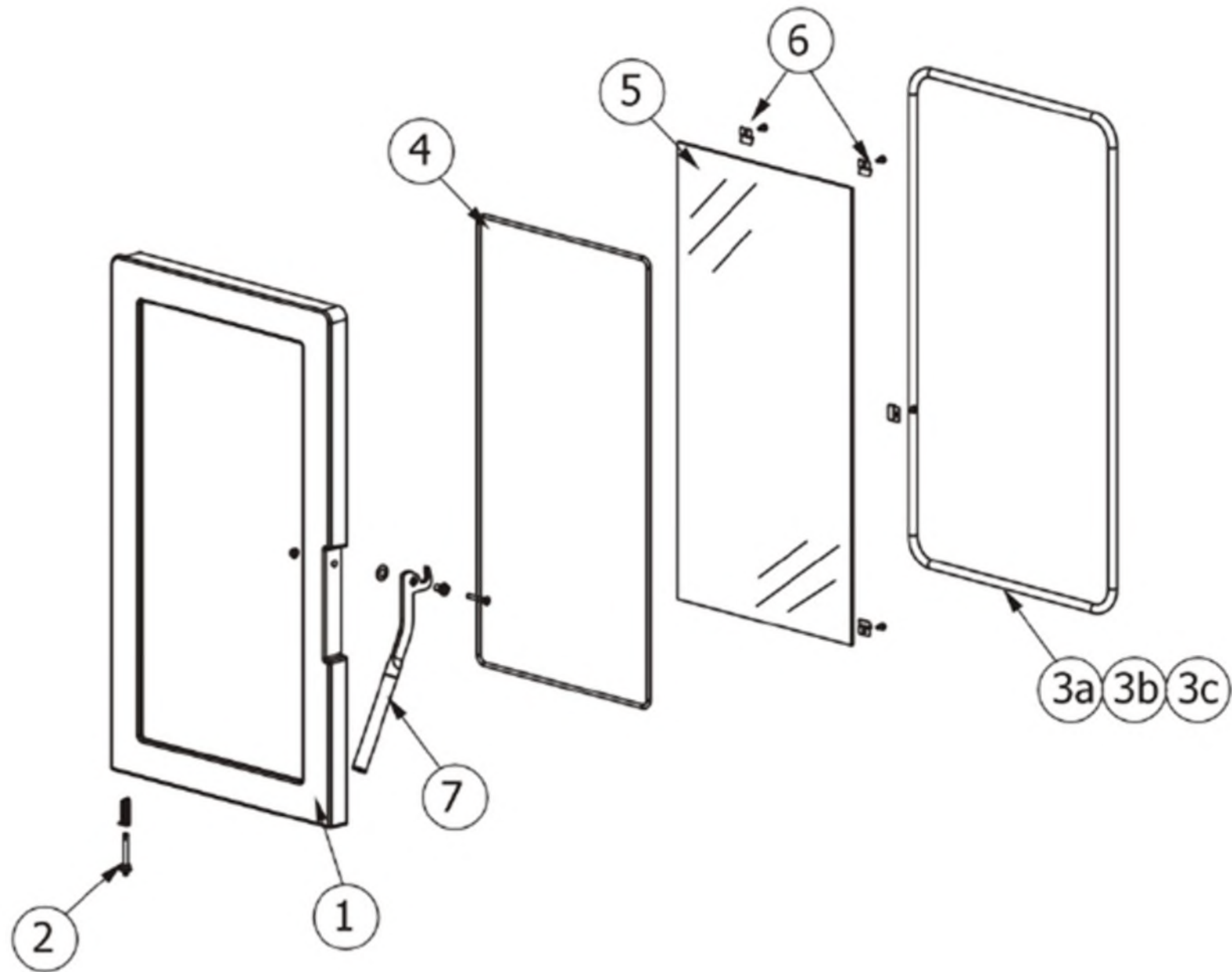

KASAI

Porta fuoco / Fire door / Feuertür / Porte foyer / Puerta hogar

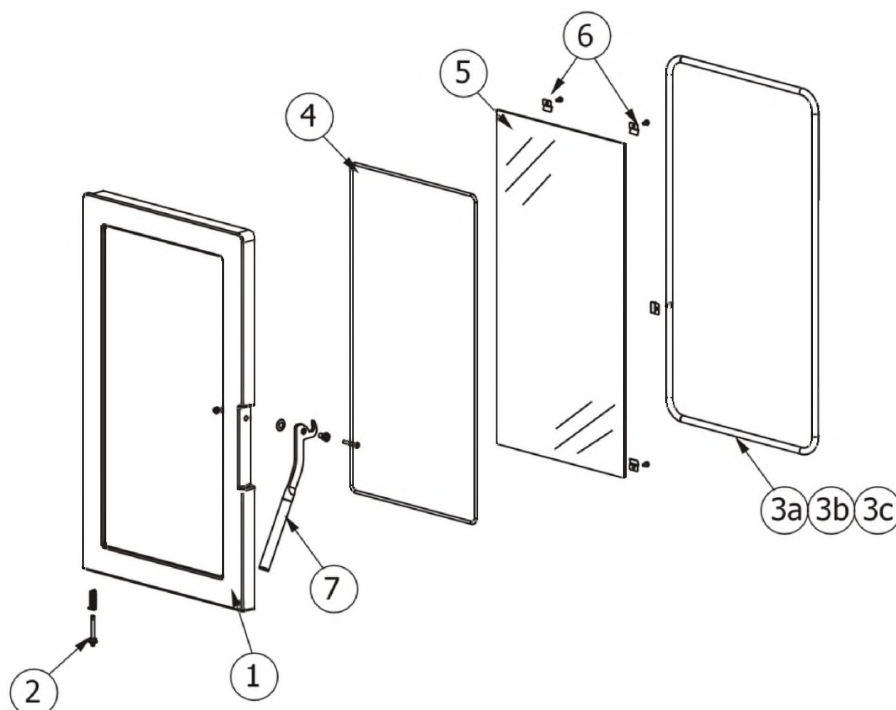

N°	Codice/Code	Descrizioni / Description / Beschreibung / Description / Descripción	Prezzo (€)
1	41301004801	Telaio porta fuoco / Fire door frame / Feuertürrahmen / Cadre porte foyer / Armazón puerta de arrabio	153.00
2	41201007400	Perno e molla porta fuoco / Door spring and pivot / Türscharnierstift und -feder / Pivot et ressort de la porte / Peral y ressorte de la puerta	25.00
3a	4120104A	Cordino fibroceramico Ø 12 mm (5 mt.) / Ceramic fibre cord Ø 12 mm (5 m.) / Keramikfaserschnur Ø 12 mm (5 m) / Cordon en fibre céramique Ø 12 mm (5 m) / Junta a cuerda de fibra cerámica Ø 12 mm (5 m)	36.00
3b	4120104B	Cordino fibroceramico Ø 12 mm (50 mt.) / Ceramic fibre cord Ø 12 mm (50 m.) / Keramikfaserschnur Ø 12 mm (50 m) / Cordon en fibre céramique Ø 12 mm (50 m) / Junta a cuerda de fibra cerámica Ø 10 mm (52 m)	210.00
3c	41201041	Kit sostituzione cordino (cordino+silicone) Ø 12 mm / Cord replacement kit (cord + silicon) Ø 12 mm / Schnuraustauschsatz (Schnur+Silikon) Ø 12 mm / Kit remplacement cordon (cordon + silicone) Ø 12 mm / Kit sustitución junta a cuerda (junta a cuerda+silicón) Ø 12 mm	50.00
4	4120106	Guarnizione a nastro fireglass / Fireglass tape gasket / Banddichtung Fireglass / Joint ruban Fireglass / Guarnición a cinta Fireglass	28.00
5	41701100460	Vetroceramico con guarnizione / Glass with gasket / Glaskeramikscheibe mit Dichtung / Vitrocéramique avec joint / Cristal cerámico con guarnición	305.00
6	41401077430	Staffe di fissaggio vetroceramico (4 pz.) / Pyroceram fastening brackets (4 pcs.) / Befestigungsbügel Glaskeramik (4 Stck.) / Étrier de fixation vitrocéramique (4 pz.) / Abrazaderas de fijación vidrio cerámico (4 piezas)	21.00
7	41401110350	Maniglia completa / Complete handle / Kompletter Griff / Poignée complète / Tirador completo	93.00

KASAI

Kit di ventilazione forzata / Forced ventilation kit / Bausatz Zwangsbelüftung / Kit de ventilation forcée /
Kit de ventilación forzada

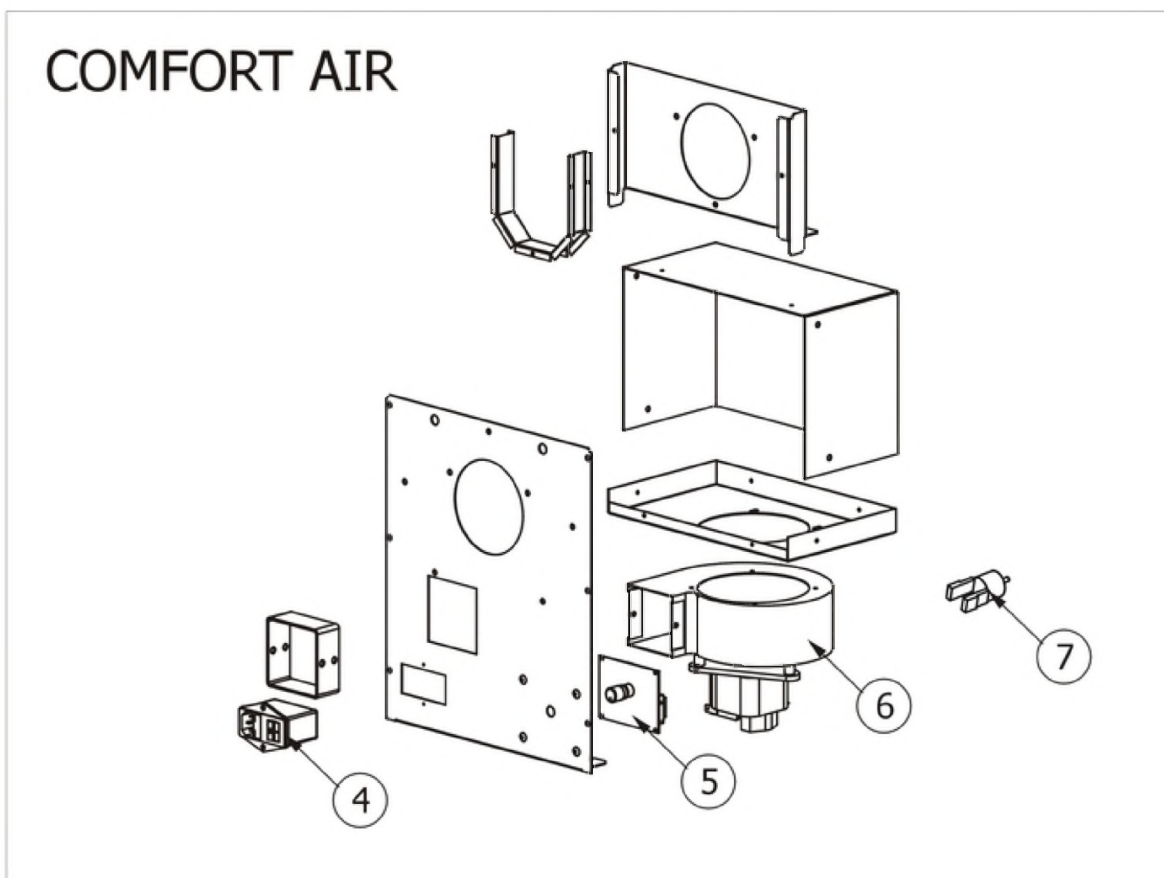
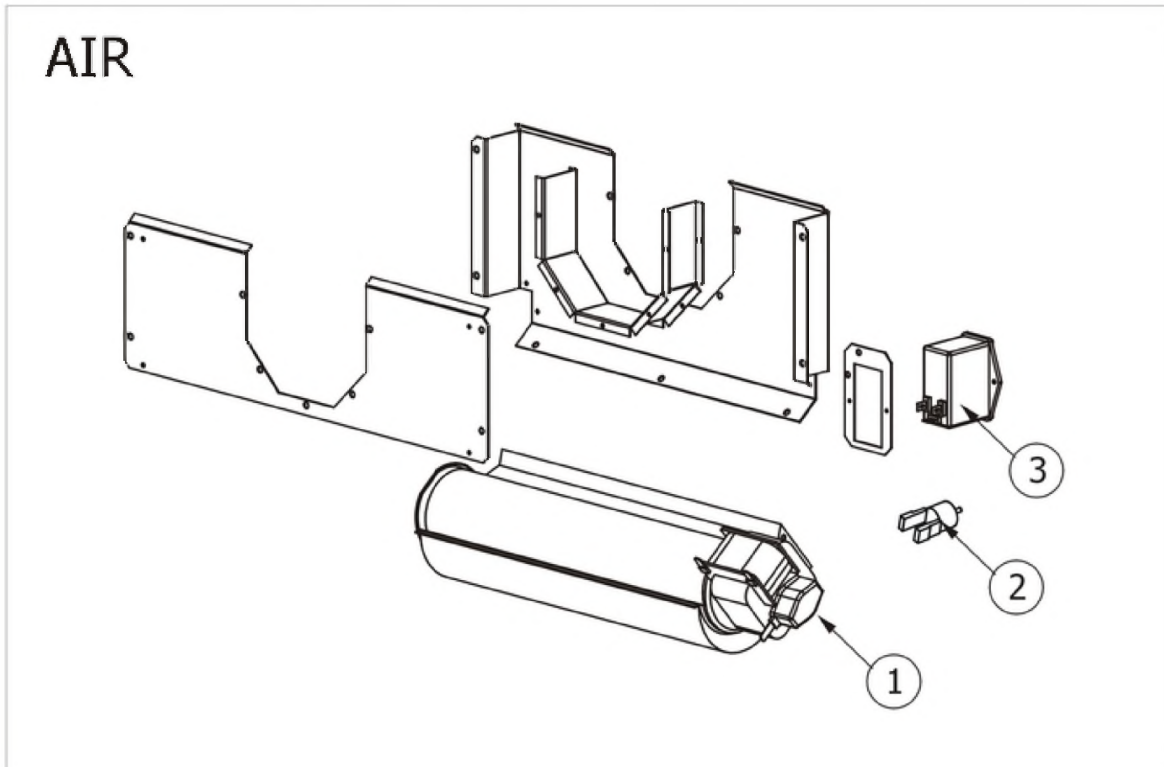

N°	Codice/Code	Descrizioni / Description / Beschreibung / Description / Descripcion	Prezzo (€)
1	41451002800	Ventilatore aria calda / Warm air fan / Warmluftgebläse / Ventilateur air chaud / Ventilador aire caliente	74.00
2	4180020	Sonda di temperatura per FC 700 / Temperature sensor for FC 700 / Temperaturfühler für FC 700 / Sonde température pour FC 700 / Sonda de temperatura para FC 700	30.00
3	4160459	Pulsante accensione / On/Off button / Zündungstaste / Touche d'allumage / Botón encendido	37.00
4	4160459	Pulsante accensione / On/Off button / Zündungstaste / Touche d'allumage / Botón encendido	37.00
5	41451106600	Regolatore di potenza del ventilatore / Power-Controller Fan / Warmluftventilatorsleistungsregler / Regoleateur de la puissance du ventilateur / Regulador de la potencia del ventilador	63.00
6	41451002903	Motore ventilatore portata 170 m3/h / Fan motor capacity 170 m3/h / Gebläsemotor Leistung 170 m3/h / Moteur ventilateur débit 170 m3/h / Motor ventilador caudal 170 m3/h	87.00
7	4180020	Sonda di temperatura per FC 700 / Temperature sensor for FC 700 / Temperaturfühler für FC 700 / Sonde température pour FC 700 / Sonda de temperatura para FC 700	30.00