

LINEA COMFORT AIR

Componenti Struttura Esterna / External structure components / Bauteile Aussenkorpus / Composants structure externe / Componentes estructura externa

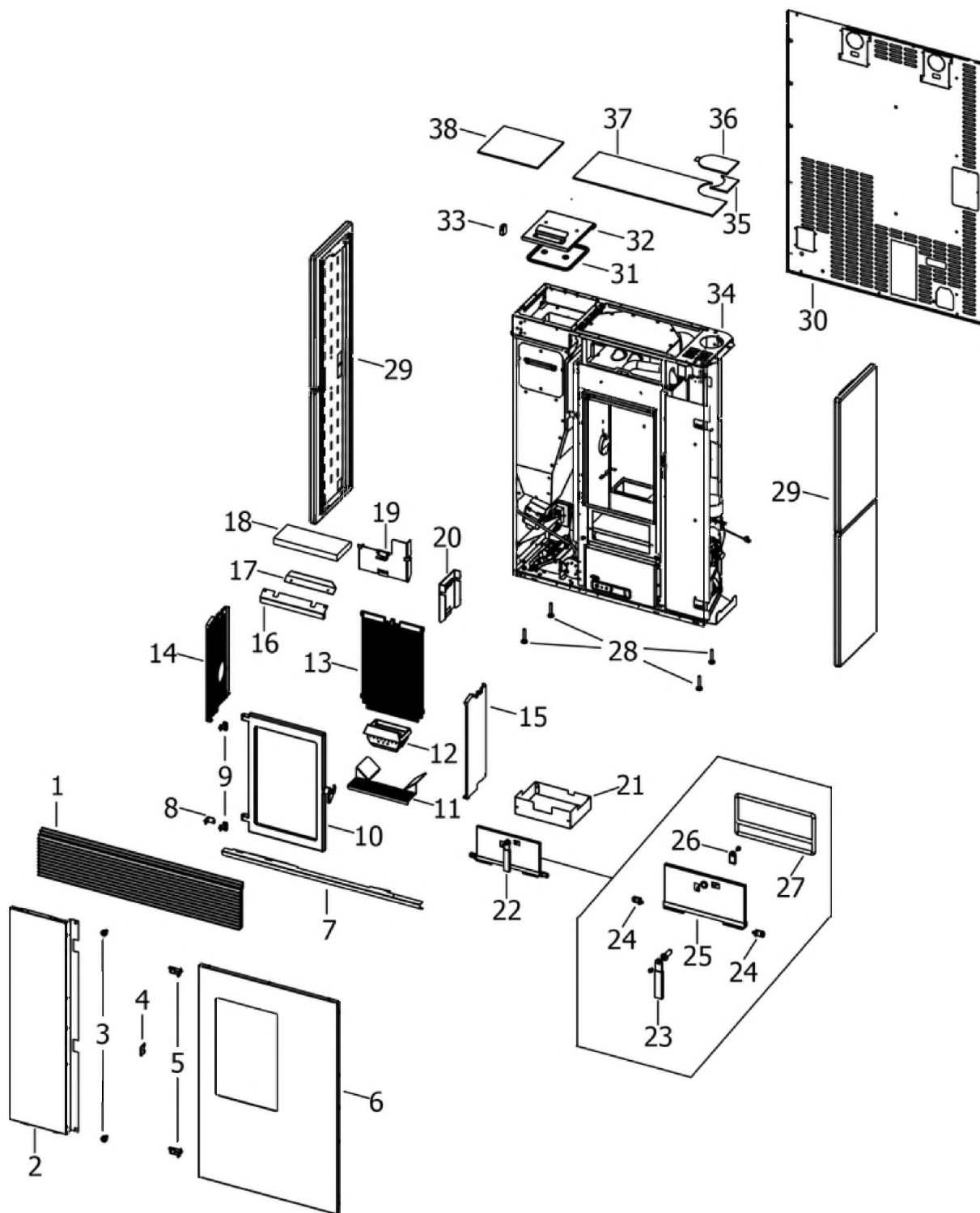

N°	Codice/Code	Descrizioni / Description / Beschreibung / Description / Description	Prezzo (€)
1	41311600220P	Griglia anteriore nera alluminio / Front black aluminum grille / Vordere Aluminium schwarze Gitter / Grille antérieur aluminium noire / Rejilla anterior aluminio negra	160.00
2	41411744650	Frontale sinistro completo / Complete left front panel / Komplettes linke vordere Paneel / Panneau frontal gauche complet / Panel frontal IZDO completo	318.00

MCZ GROUP

LINEA COMFORT AIR

Componenti Struttura Esterna / External structure components / Bauteile Aussenkorpus / Composants structure externe / Componentes estructura externa

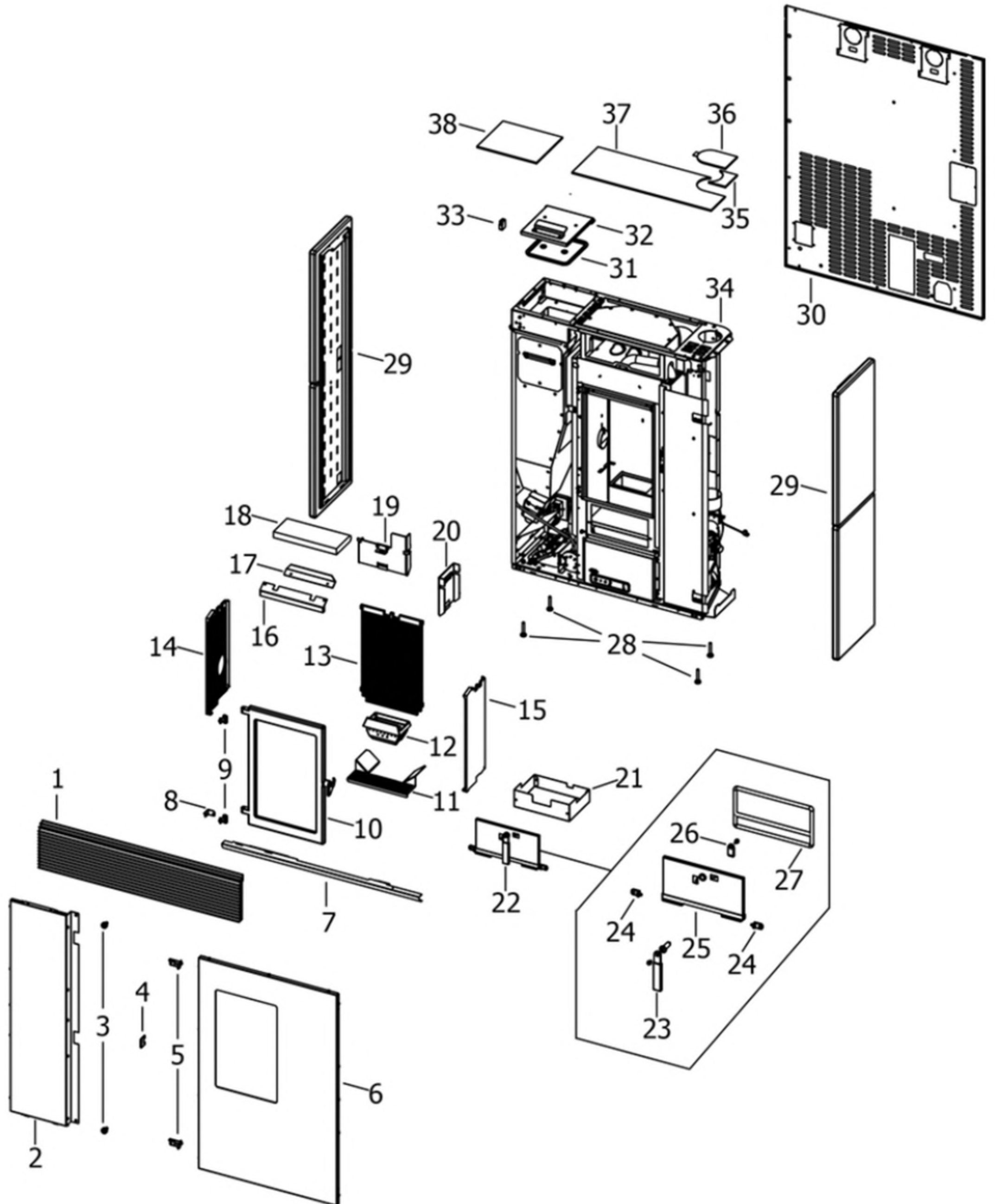

3	41801657900	Magneti (pz.2) / Magnet (pcs.2) / Magnet (stk. 2) / Aimant (pcs.2) / Imán (pz.2)	22.00
4	41411744460	Maniglia porta esterna / External door handle / Außentür Griff / Poignée porte extérieur / Tirador puerta exterior	19.00
5	41411744540V	Cerniera porta esterna / External door hinge / Außentür Scharnier / Charnière porte extérieur / Bisagra puerta exterior	31.00
6	41411743550	Porta completa esterna / Complete external door / Komplette Außentür / Porte externe complète / Puerta externa completa	637.00
7	41411743430P	Profilo inferiore nero / Black lower profile / Unteres schwarze Profil / Profil inférieur noir / Perfil inferior negro	50.00
8	41411742730V	Blocco porta focolare / Stop for Fireplace door / Stopper für Feuerstelle Tür / Stop pour porte foyer / Tope por puerta hogar	16.00
9	41201504460	Cerniera porta (2 pz.) / Door hinge (2 pc.) / Tür Scharnier (2 Stk.) / Charnière porte (2 pc.) / Bisagra puerta (2)	24.00
10	437017119	Porta focolare / Fireplace door / Feuerstelle Tür / Porte foyer / Puerta hogar	199.00
11	41411742230V	Griglia focolare / Fire box grille / Feuerstellenrost / Grille foyer / Rejilla hogar	35.00
12	4130170030100	Braciere ghisa / Cast iron brazier / Brennschale aus Guß / Brasero en fonte / Brasero de arrabio	51.00
13	41301700700V	Schiena in ghisa / Cast iron back / Rückwand aus Guß / Fond en fonte / Parte trasera de arrabio	52.00
14	41301700600V	Fianco sinistro in ghisa / Left cast iron side / Linke Seite aus Guß / Coté gauche en fonte / Placa lateral izquierda de arrabio	42.00
14	41411613530V	Deflettore pellet / Pellet deflector / Pellet Leitblech / Déflecteur pellet / Deflector pellet	23.00
15	41301700500V	Fianco destro in ghisa / Right cast iron side / Rechte Seite aus Guß / Coté droit en fonte / Placa lateral derecha de arrabio	41.00
16	4141174234100	Deflettore pulizia vetro / Deflector for glass cleaning / Leitblech für Glassreinigung / Déflecteur pour nettoyage du verre / Deflector por limpieza vidrio	38.00
17	41331702030	Protezione focolare inox / Inox fire protection / Feuerschutz aus Edelstahl / Protection foyer inox / Protección hogar inox	21.00
18	41151702000	Deflettore vermiculite / Vermiculite deflector / Leitblech aus Vermiculite / Déflecteur en vermiculite / Deflector en vermiculite	20.00
19	41411740131	Tappo post. pulizia struttura / Rear cap for structure cleaning / Hinterer Stöpsel für Korpus Reinigung / Bouchon postérieur pour nettoyage structure / Tapon posterior por limpieza estructura	44.00
20	41411740231	Tappo lat. pulizia struttura / Lateral cap for structure cleaning / Seitlicher Stöpsel für Korpus Reinigung / Bouchon lateral pour nettoyage structure / Tapon lateral por limpieza estructura	43.00
21	41401713930	Cassetto cenere / Ash drawer / Aschenkasten / Tiroir à cendres / Cajón ceniza	38.00
22	437017126	Porta cenere / Ash drawer door / Tür des Aschenkastens / Porte tiroir à cendres / Puerta cajón ceniza	90.00
23	41411621600	Maniglia con impugnatura porta cenere / Handle / Griff / Poignée / Tirador	20.00
24	41411623740V	Cerniera acciaio porta cenere / Ash compartment door steel hinge / Aschenklappe Stahlscharnier / Charnier en acier porte compartiment cendre / Bisagra en acero puerta compartimento cenizas	23.00
24	41411623740V	Cerniera acciaio porta cenere / Ash compartment door steel hinge / Aschenklappe Stahlscharnier / Charnier en acier porte compartiment cendre / Bisagra en acero puerta compartimento cenizas	23.00
25	41411742440V	Porta cenere / Ash drawer door / Tür des Aschenkastens / Porte tiroir à cendres / Puerta cajón ceniza	65.00
26	41201608400	Serratura porta cassetto cenere / Door lock for ash drawer / Türschloss für Aschenkasten / Serrure de porte du tiroir à cendres / Cerradura puerta cajón ceniza	20.00
27	412007003A	Cordino fibroceramico Ø 14 mm (5 mt.) / Ceramic fibre cord Ø 14 mm (5 m.) / Keramikfaserschnur Ø 14 mm (5 m) / Cordon en fibre céramique Ø 14 mm (5 m) / Junta a cuerda de fibra cerámica Ø 14 mm (5 m)	44.00
27	412007003B	Cordino fibroceramico Ø 14 mm (50 mt.) / Ceramic fibre cord Ø 14 mm (50 m.) / Keramikfaserschnur Ø 14 mm (50 m) / Cordon en fibre céramique Ø 14 mm (50 m) / Junta a cuerda de fibra cerámica Ø 14 mm (50 m)	300.00
27	412007003C	Kit sostituzione cordino (cordino+silicone) Ø 14 mm / Cord replacement kit (cord + silicon) Ø14 mm / Schnuraustauschsatz (Schnur +Silikon) Ø 14 mm / Kit remplacement cordon (cordon+silicon) Ø 14 / Kit sustitución junta a cuerda (junta a cuerda+silicón) Ø 14 mm	70.00
28	41200906660	Piedini di appoggio (4 pz.) / Support feet (4 pcs.) / Einstellfüße (4 Stck.) / Vérins d'appui (4 p.es) / Pies de apoyo (4 piezas)	19.00
29	41251700250	Ceramiche laterali Black / Black side ceramics / Seitliche Keramik Black / Carreaux latéraux en céramique Black / Cerámicas laterales Black	300.00
29	41251700350	Ceramiche laterali Bordeaux / Bordeaux side ceramics / Seitliche Keramik Bordeaux / Carreaux latéraux en céramique Bordeaux / Cerámicas laterales Bordeaux	309.00
29	41251700450	Ceramiche laterali White / White side ceramics / Seitliche Keramik White / Carreaux latéraux en céramique White / Cerámicas laterales White	299.00
29	41251700950	Laterale Serpentino / Lateral Serpentine / Seite aus Serpentino / Latérale Serpentine / Lateral Serpentino	393.00
29	41251700250	Ceramiche laterali Black / Black side ceramics / Seitliche Keramik Black / Carreaux latéraux en céramique Black / Cerámicas laterales Black	300.00
29	41251700350	Ceramiche laterali Bordeaux / Bordeaux side ceramics / Seitliche Keramik Bordeaux / Carreaux latéraux en céramique Bordeaux / Cerámicas laterales Bordeaux	309.00

29	41251700450	Ceramiche laterali White / White side ceramics / Seitliche Keramik White / Carreaux latéraux en céramique White / Cerámicas laterales White	299.00
29	41251700950	Laterale Serpentino / Lateral Serpentine / Seite aus Serpentino / Latérale Serpentine / Lateral Serpentino	393.00
30	41401715230	Schiena posteriore / Rear back / Hintere Rückwand / Dossieret posterieur / Parte trasera	72.00
31	41801604700	Guarnizione tenuta serbatoio / Pellet hopper gasket / Pelletbehälter Dichtung / Joint réservoir pellet / Junta depósito pellet	19.00
32	41401714650	Coperchio tecnico / Technical cover / Technicher Deckel / Couvercle technique / Tapadera técnica	114.00
33	41201305100	Chiusura a spinta / Push-pull pressure closing / Druckschließung / Fermeture par pression / Cierre a presión	20.00
34	4141174103100	Support Top / Top support / Deckelhalbbugel / Support dessus / Soporte del top	81.00
35	41411746150	Tappo top completo forato / Complete drilled top cover / Komplette gebohrte Abdeckung / Couvercle percé complet dessus / Tapon perforado completo del top	159.00
36	41411746050	Tappo top completo cieco / Complete blind top cover / Komplette blinde Abdeckung / Couvercle aveugle complet dessus / Tapon ciego completo del top	103.00
37	41411745550	Top vetro completo / Complete glass top / Komplette Glasdeckel / Dessus en verre complet / Top de cristal completo	420.00
38	41701701360	Vetro temperato tappo serbatoio c/serigrafia / Tempered glass hopper cover w/serigraph / Temperglas Deckel Behälter mit Siebdruck / Verre tempéré couvercle réservoir / Vidrio templado tapa depósito	98.00

MCZ GROUP

LINEA COMFORT AIR

Porta fuoco / Fire door / Feuertür / Porte foyer / Puerta hogar

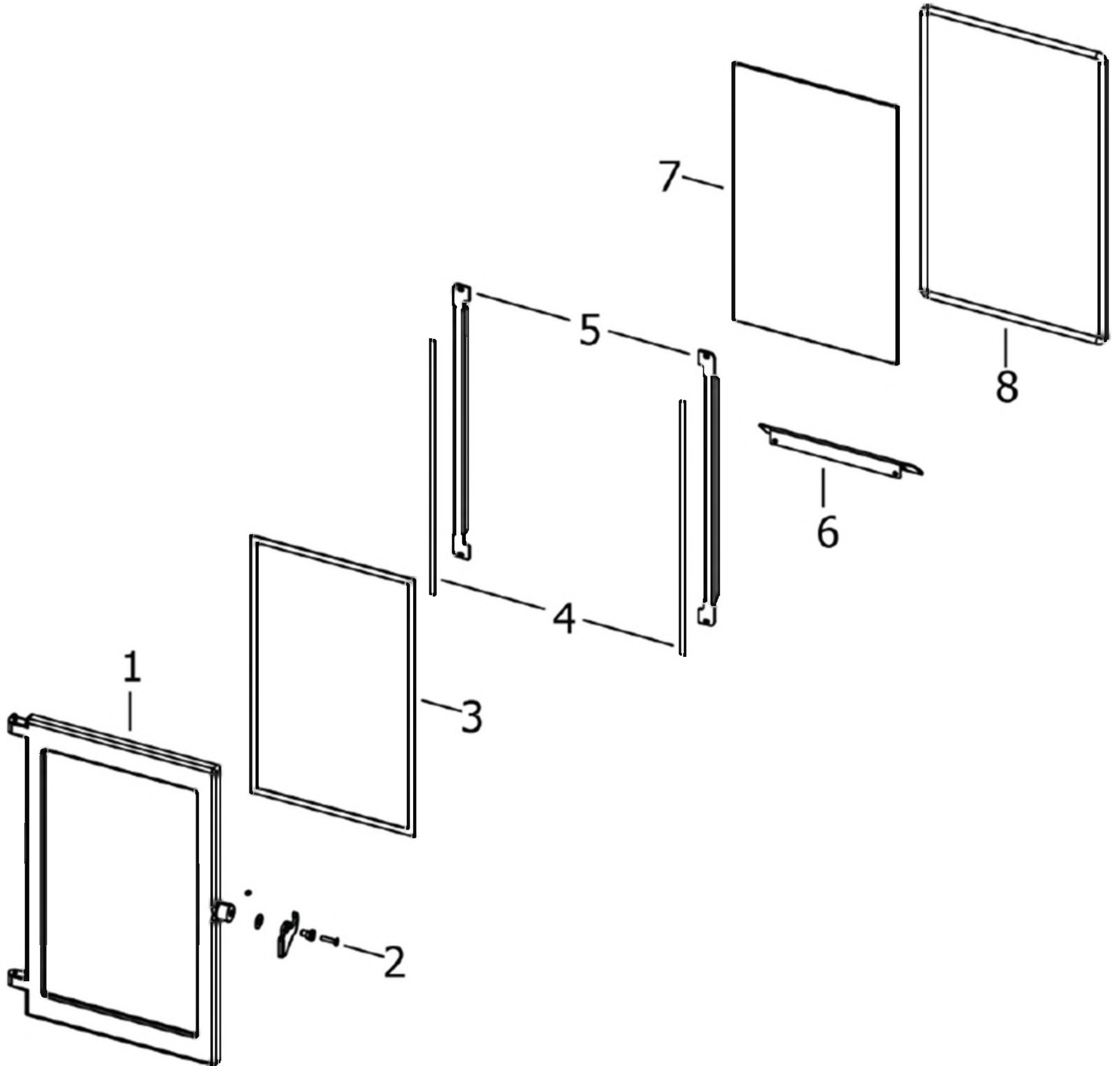

LINEA COMFORT AIR

Porta fuoco / Fire door / Feuertür / Porte foyer / Puerta hogar

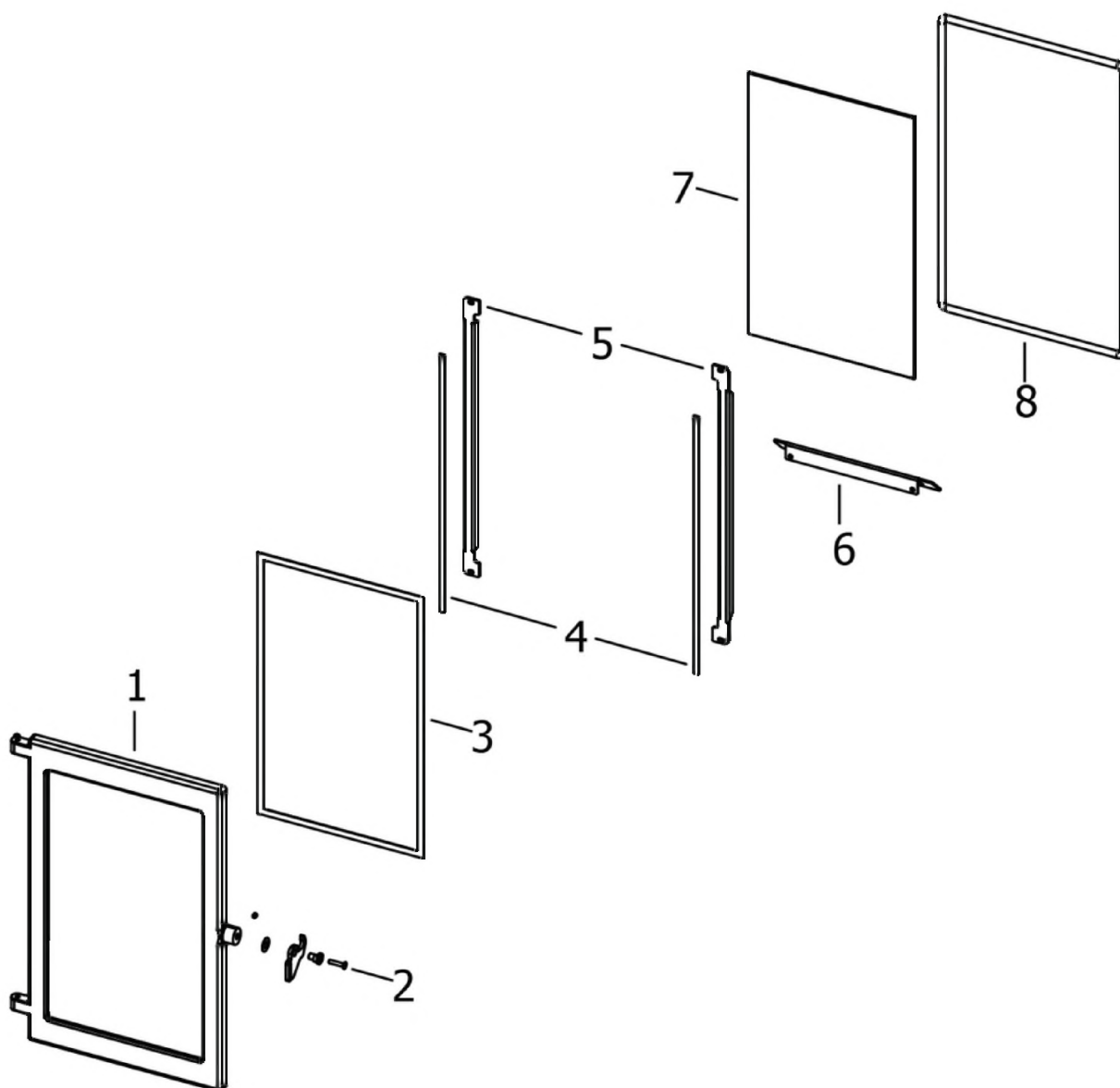

N°	Codice/Code	Descrizioni / Description / Beschreibung / Description / Descripción	Prezzo (€)
1	41301700400V	Porta focolare ghisa / Cast iron fire door / Feuertür aus Guß / Porte foyer en fonte / Puerta hogar de arrabio	80.00
2	41411742161	Maniglia porta focolare / Fire door handle / Feuertür Griff / Poignée porte foyer / Tirador puerta fuego	28.00
3	41801603300A	Guarnizione Ø5 5mt / Gasket Ø5 5mt / Dichtung Ø5 5mt / Joint Ø5 5mt / Junta Ø5 5mt	42.00
3	41801603300B	Guarnizione Ø5 50mt / Gasket Ø5 50mt / Dichtung Ø5 50mt / Joint Ø5 50mt / Junta Ø5 50mt	299.00
3	41801603300C	Guarnizione Ø5 5mt + silicone / Gasket Ø5 5mt + silic / Dichtung Ø5 5mt + Silikon / Joint Ø5 5mt + silic / Junta Ø5 5mt	63.00
4	4120573A	Guarnizione a nastro 8 mm (5 mt.) per porta / Door strip gasket 8 mm (5 m) / Türbanddichtung 8 mm (5 m) / Joint ruban 8 mm (5 m) pour porte / Guarnición de cinta para puerta 8 mm (5 m)	32.00
4	4120573B	Guarnizione a nastro 8 mm (50 mt.) per porta / Door strip gasket 8 mm (50 m) / Türbanddichtung 8 mm (50 m) / Joint ruban 8 mm (50 m) pour porte / Guarnición de cinta para puerta 8 mm (50 m)	162.00
5	4160170440000	Profilo fermavetro / Fastening bracket profile / Haltebügel für Scheibebefestigung Profil / Profil patte de fixation / Perfil fermacristal	42.00
6	4141174203100	Scivolo cenere / Ash ramp / Aschenrutsche / Glissèrie cendre / Tobogán ceniza	37.00
7	41701701800	Vetroceramico porta tecnica / Technical door glass / Glas für technische Tür / Vitrocéramique porte technique / Cristal cerámico puerta técnica	94.00
8	4120104A	Cordino fibroceramico Ø 12 mm (5 mt.) / Ceramic fibre cord Ø 12 mm (5 m.) / Keramikfaserschnur Ø 12 mm (5 m) /	36.00

		Cordon en fibre céramique Ø 12 mm (5 m) / Junta a cuerda de fibra cerámica Ø 12 mm (5 m)	
8	4120104B	Cordino fibroceramico Ø 12 mm (50 mt.) / Ceramic fibre cord Ø 12 mm (50 m.) / Keramikfaserschnur Ø 12 mm (50 m) / Cordon en fibre céramique Ø 12 mm (50 m) / Junta a cuerda de fibra cerámica Ø 10 mm (52 m)	210.00
8	41201041	Kit sostituzione cordino (cordino+silicone) Ø 12 mm / Cord replacement kit (cord + silicon) Ø 12 mm / Schnuraustauschsatz (Schnur+Silikon) Ø 12 mm / Kit remplacement cordon (cordon + silicone) Ø 12 mm / Kit sustitución junta a cuerda (junta a cuerda+silicon) Ø 12 mm	50.00

MCZ GROUP

LINEA COMFORT AIR

Gruppo frontale / Frontal group / Frontgruppe / Groupe frontale / Grupo frontal

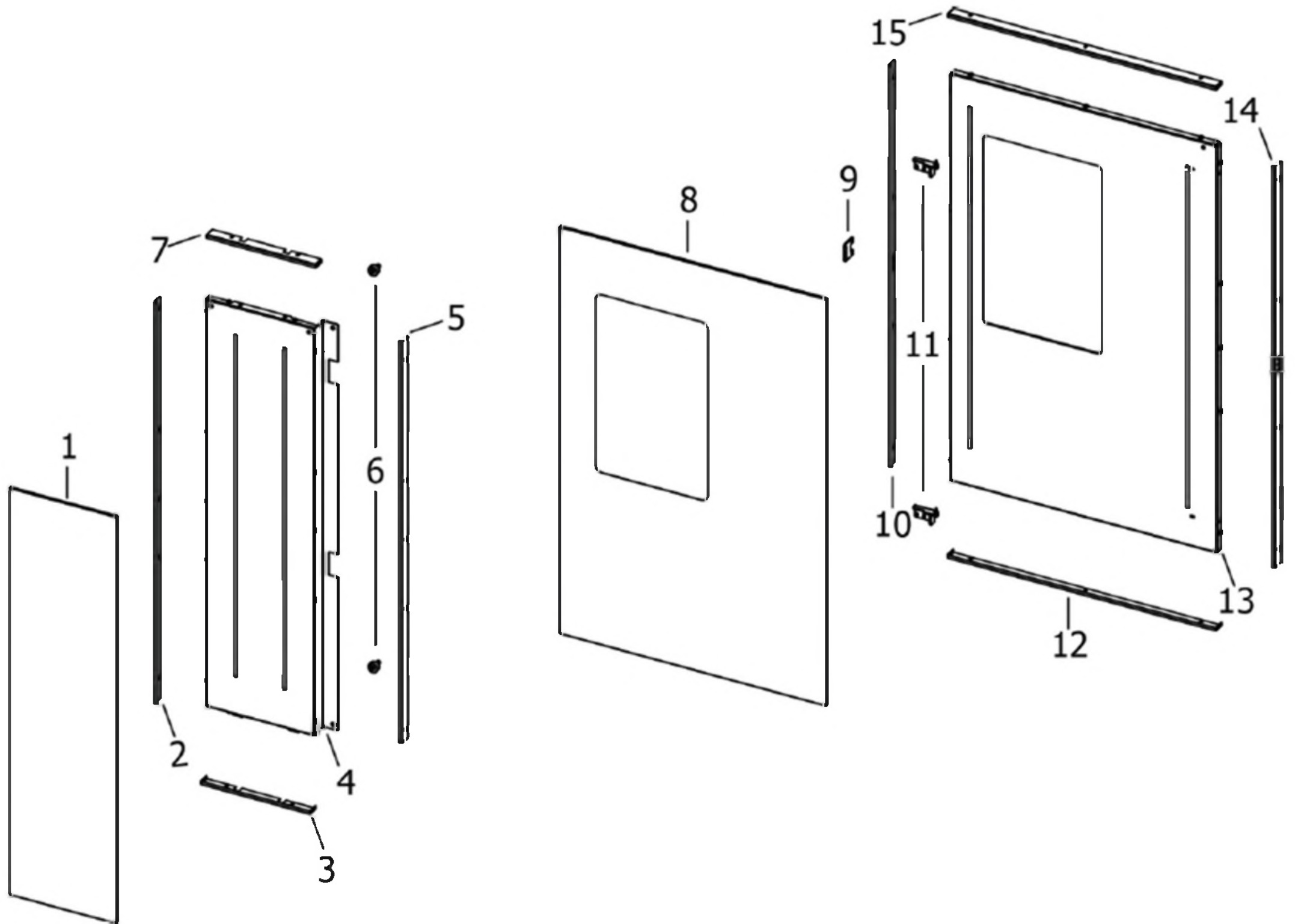

LINEA COMFORT AIR

Gruppo frontale / Frontal group / Frontgruppe / Groupe frontale / Grupo frontal

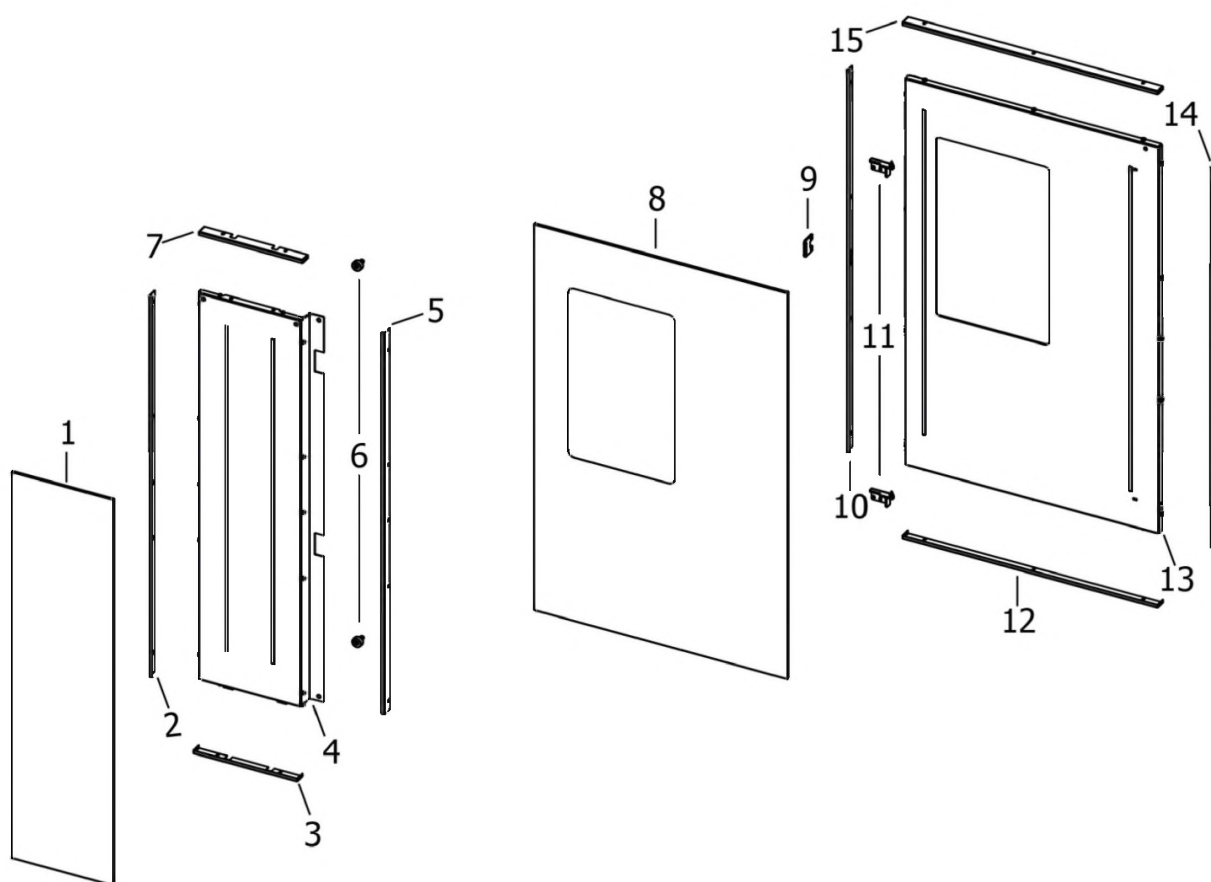

N°	Codice/Code	Descrizioni / Description / Beschreibung / Description / Descripción	Prezzo (€)
1	41701701260	Vetroceramico frontale sinistro con serigrafia / Front left glass / Vordere linke Glaskeramikscheibe / Vitroc�ramique frontal gauche / Cristal cer�mico frontal izquierdo	166.00
1	4120572A	Guarnizione a nastro 6 mm (5 mt.) per porta / Door strip gasket 6 mm (5 m) / T�rbanddichtung 6 mm (5 m) / Joint ruban 6 mm (5 m) pour porte / Guarnici�n de cinta para puerta 6 mm (5 m)	33.00
1	4120572B	Guarnizione a nastro 6 mm (50 mt.) per porta / Door strip gasket 6 mm (50 m) / T�rbanddichtung 6 mm (50 m) / Joint ruban 6 mm (50 m) pour porte / Guarnici�n de cinta para puerta 6 mm (50 m)	210.00
2	41411744930P	Fermavetro laterale frontale / Lateral front glass fastening bracket / Vordere Seitenhalteb�gel f�r Scheibebefestigung / Etrier de fixation lateral frontal vitroc�ramique / Retendor lateral frontal del cristal	45.00
3	41411744830P	Fermavetro sup./inf. telaio frontale / Sup./inf. glass fastening bracket - frontal frame / Ob./Unt. Halteb�gel f�r Scheibebefestigung - vordere Rahmen / Etrier de fixation sup./inf. vitroc�ramique - cadre frontal / Retendor sup./inf. del cristal - Armaz�n frontal	28.00
4	4141174474000	Telaio frontale sinistro / Left front frame / Linke vorderer Rahmen / Cadre frontal gauche / Armaz�n frontal IZDO	52.00
4	4120572A	Guarnizione a nastro 6 mm (5 mt.) per porta / Door strip gasket 6 mm (5 m) / T�rbanddichtung 6 mm (5 m) / Joint ruban 6 mm (5 m) pour porte / Guarnici�n de cinta para puerta 6 mm (5 m)	33.00
4	4120572B	Guarnizione a nastro 6 mm (50 mt.) per porta / Door strip gasket 6 mm (50 m) / T�rbanddichtung 6 mm (50 m) / Joint ruban 6 mm (50 m) pour porte / Guarnici�n de cinta para puerta 6 mm (50 m)	210.00
5	41411744930P	Fermavetro laterale frontale / Lateral front glass fastening bracket / Vordere Seitenhalteb�gel f�r Scheibebefestigung / Etrier de fixation lateral frontal vitroc�ramique / Retendor lateral frontal del cristal	45.00
6	41801657900	Magneti (pz.2) / Magnet (pcs.2) / Magnet (stk. 2) / Aimant (pcs.2) / Im�n (pz.2)	22.00
7	41411744830P	Fermavetro sup./inf. telaio frontale / Sup./inf. glass fastening bracket - frontal frame / Ob./Unt. Halteb�gel f�r Scheibebefestigung - vordere Rahmen / Etrier de fixation sup./inf. vitroc�ramique - cadre frontal / Retendor sup./inf. del cristal - Armaz�n frontal	28.00
8	41701701160	Vetroceramico con serigrafia / Glass / Glaskeramikscheibe / Vitroc�ramique / Cristal cer�mico	270.00
8	4120572A	Guarnizione a nastro 6 mm (5 mt.) per porta / Door strip gasket 6 mm (5 m) / T�rbanddichtung 6 mm (5 m) / Joint ruban 6 mm (5 m) pour porte / Guarnici�n de cinta para puerta 6 mm (5 m)	33.00
8	4120572B	Guarnizione a nastro 6 mm (50 mt.) per porta / Door strip gasket 6 mm (50 m) / T�rbanddichtung 6 mm (50 m) / Joint ruban 6 mm (50 m) pour porte / Guarnici�n de cinta para puerta 6 mm (50 m)	210.00

9	41411744460	Maniglia porta esterna / External door handle / Außentür Griff / Poignée porte extérieur / Tirador puerta exterior	19.00
10	41411744230P	Fermavetro laterale porta esterna / Lateral glass fastening bracket - External door / Seitenhaltebügel für Scheibebefestigung - Außentür / Etrier de fixation lateral vitrocéramique - porte extérieur / Retendor lateral del cristal - Puerta exterior	35.00
11	41411744540V	Cerniera porta esterna / External door hinge / Außentür Scharnier / Charnière porte extérieur / Bisagra puerta exterior	31.00
12	41411744330P	Fermavetro superiore/inferiore porta esterna / Upper/lower glass fastening bracket - External door / Obere/Untere Haltebügel für Scheibebefestigung - Außentür / Etrier de fixation supérieur/inférieur vitrocéramique - porte extérieur / Retendor superior/inferior del cristal - Puerta exterior	32.00
13	41411743640V	Telaio porta esterna / External door frame / Außentür Rahmen / Cadre porte externe / Armazón puerta externa	312.00
13	4120572A	Guarnizione a nastro 6 mm (5 mt.) per porta / Door strip gasket 6 mm (5 m) / Türbanddichtung 6 mm (5 m) / Joint ruban 6 mm (5 m) pour porte / Guarnición de cinta para puerta 6 mm (5 m)	33.00
13	4120572B	Guarnizione a nastro 6 mm (50 mt.) per porta / Door strip gasket 6 mm (50 m) / Türbanddichtung 6 mm (50 m) / Joint ruban 6 mm (50 m) pour porte / Guarnición de cinta para puerta 6 mm (50 m)	210.00
14	41411744230P	Fermavetro laterale porta esterna / Lateral glass fastening bracket - External door / Seitenhaltebügel für Scheibebefestigung - Außentür / Etrier de fixation lateral vitrocéramique - porte extérieur / Retendor lateral del cristal - Puerta exterior	35.00
15	41411744330P	Fermavetro superiore/inferiore porta esterna / Upper/lower glass fastening bracket - External door / Obere/Untere Haltebügel für Scheibebefestigung - Außentür / Etrier de fixation supérieur/inférieur vitrocéramique - porte extérieur / Retendor superior/inferior del cristal - Puerta exterior	32.00

MCZ GROUP

LINEA COMFORT AIR

Componenti interni meccanici ed elettronici / **Electronic and mechanic internal parts** / Interne mechanische und elektronische Bauteile / Composants internes mécaniques et électroniques / Componentes internos electrónicos y mecánicos

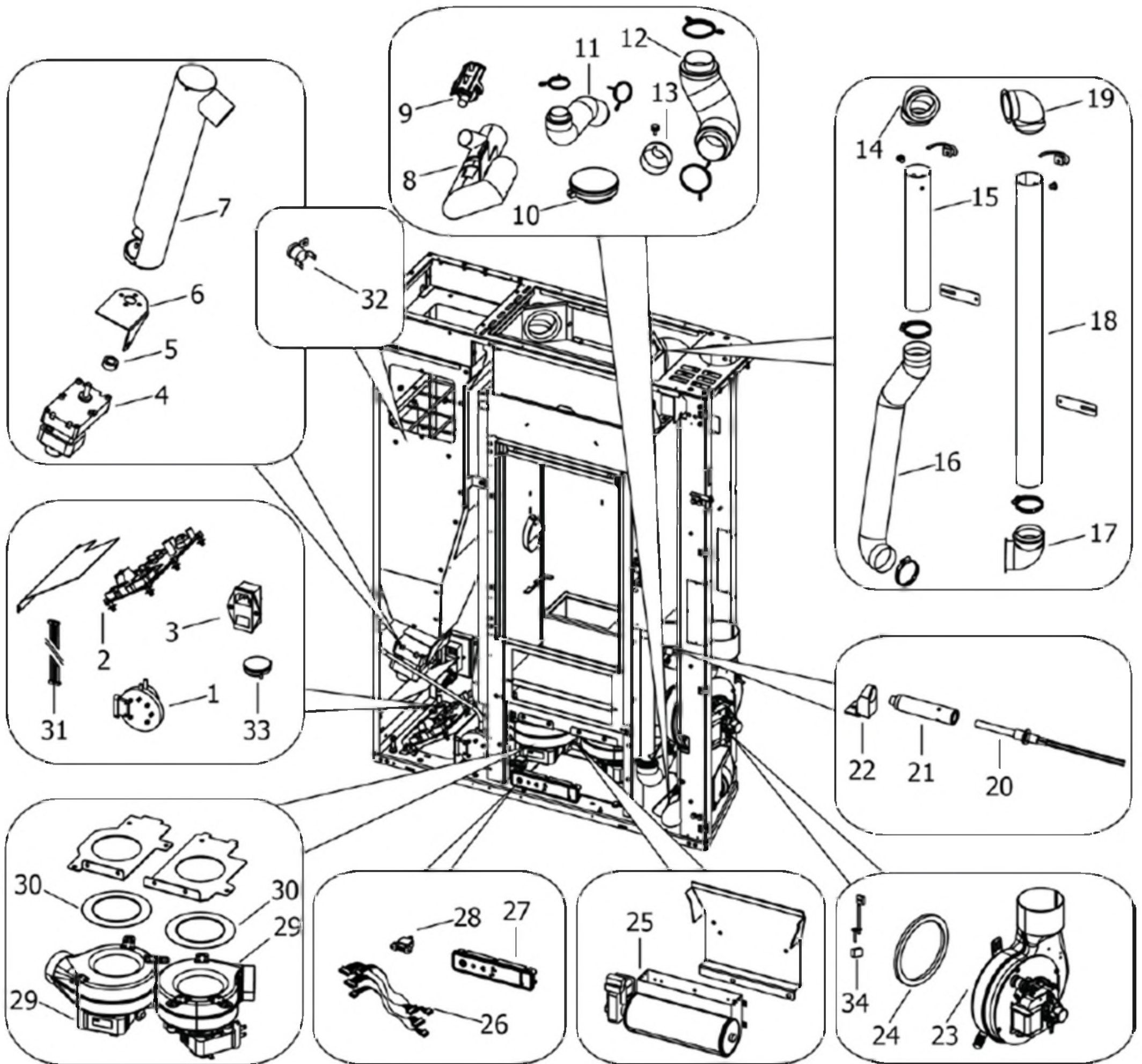

LINEA COMFORT AIR

Componenti interni meccanici ed elettronici / Electronic and mechanic internal parts / Interne mechanische und elektronische Bauteile / Composants internes mécaniques et électroniques / Componentes internos electrónicos y mecánicos

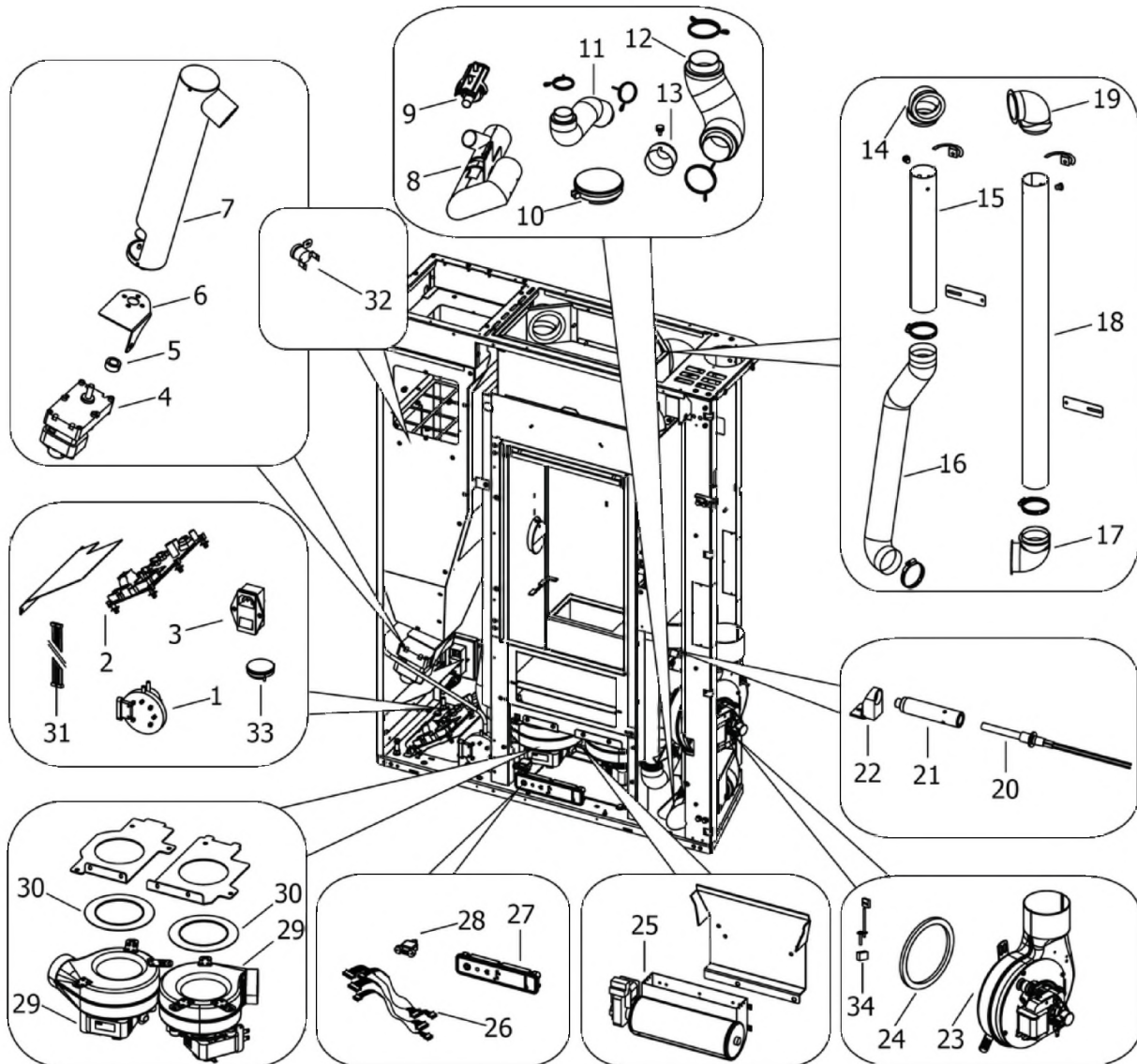

N°	Codice/Code	Descrizioni / Description / Beschreibung / Description / Descripción	Prezzo (€)
1	41451003700	Pressostato / Pressure switch / Druckschalter / Pressostat / Presostato	40.00
2	41451602602	Scheda elettronica plus / Electronix mother board plus / Elektronische Platine Plus / Carte mère électronique plus / Tarjeta madre electronica plus	191.00
3	4160193	Pulsante accensione / On/Off button / Zündungstaste / Touche d'allumage / Botón encendido	28.00
4	41451503100	Motoriduttore 2rpm / Gear motor 2rpm / Getriebemotor 2rpm / Motoréducteur 2rpm / Motorreductor 2rpm	102.00
5	4120398	Connettore motoriduttore-coclea / Reduction motor-feed screw connector / Verbindung Getriebemotor-Schnecke / Connecteur motoréducteur-vis sans fin / Conector motorreductor-cóclea	22.00
6	41401623830	base coclea pellet / Feed screw base for pellet / Untergestell der Förderschnecke für Pellet / Base de la vis sans fin granulés / Base de la coclea pellets	29.00
7	41411741151	Alimentazione completa / Complete power / Komplette Anspeisung / Alimentation complète / Alimentacion completa	139.00
7	41801600400	Guarnizione gruppo caricamento / Gasket / Dichtung / Joint / Junta	20.00
7	41801702600	Disaccoppiatore misc. Marrone / Brown disengaging device / Braun Verängungsrohr / Tuyau de découplage maron / Tubo de desvío marron	18.00
8	41601703360	Tubo aspirazione zincato / Zinc-coated air inlet pipe / Verzinkter Lufteingangsrohr / Tuyau entrée d'air galvanisé / Tubo entrada aire cincando	65.00

9	41601301850	Componente rilevamento portata aria / Air flow measure component / Bauteil für Messung der Luftmenge / Composent pour la mesuration de la quantité d'air / Componente por la medida de l'aire	34.00
10	41451303400	Trasduttore di pressione / Pressure transducer / Active-Wandler / Transducteur de pression / Transductor de pression	58.00
10	4120631A	Tubicino siliconico - 5m / Silicon tube - 5m / Silikonrohr - 5m / Petit tuyau en silicone - 5m / Tubo silicónico - 5m	22.00
11	41801601900	Tubo aspirazione pulizia vetro / Inlet pipe for cleaning glass air / Glassreinigungs Lufteingangsrohr / Tuyau entrée pour l'aire de nettoyage du vitre / Tubo entrada por l'aire de limpieza vidrio	62.00
12	41801601700	Tubo aspirazione camera combustione / Combustion chamber aspiration tube / Verbrennungskammer Förderrohr / Tuyau aspiration air chambre de combustion / Tubo aspiración aire cámara de combustión	28.00
13	41401036100	Filtro antipolvere / Anti-dust filter / Staubschutzfilter / Filtre antipoussière / Filtro de protección polvo	21.00
14	41601003600	Tubo 90° / Pipe 90° / Rohr 90° / Tuyau 90° / Tubo 90°	17.00
15	41601703260	Tubo aria Ø 60 corto zincato / Short zinc-coated air pipe Ø 60 / Kurz verzinkter Luftrohr Ø 60 / Tuyau air galvanisé court Ø 60 / Tubo aire cincado corto Ø 60	31.00
16	4009003	Tubo flessibile Ø 60 mm lunghezza 1,5 m / Flex pipe Ø 60 mm lenght 1,5 m / Schlauch Ø 60 mm Länge 1,5 m / Tuyau flexible Ø 60 mm longueur 1,5 m / Tubo flexible Ø 60 mm lungueza 1,5 m	25.00
16	4009017	Tubo flessibile Ø 60 mm lunghezza 8 m / Flex pipe Ø 60 mm lenght 8 m / Schlauch Ø 60 mm Länge 8 m / Tuyau flexible Ø 60 mm longueur 8 m / Tubo flexible Ø 60 mm lungueza 8 m	50.00
17	41601003600	Tubo 90° / Pipe 90° / Rohr 90° / Tuyau 90° / Tubo 90°	17.00
18	41601703160	Tubo aria Ø 60 lungo zincato / Long zinc-coated air pipe Ø 60 / Lang verzinkter Luftrohr Ø 60 / Tuyau air galvanisé long Ø 60 / Tubo aire cincado largo Ø 60	27.00
19	41601003600	Tubo 90° / Pipe 90° / Rohr 90° / Tuyau 90° / Tubo 90°	17.00
20	41451308101	Candeletta 315 Watt / Sparkplug 315 Watt / Zündkerze 315 Watt / Bougie 315 Watt / Bujia 315 Watt	77.00
20	41451308150	Kit 25 candelette 315 Watt / 25 Sparkplugs 315 Watt kit / Bausatz 25 Zündkerzen 315 Watt / Kit 25 Bougies 315 Watt / Kit 25 Bujias 315 Watt	1,637.00
21	41201705400	Condotto candeletta / Sparkplug conduit / Zündkerzenkanal / Conduit bougie / Conducto bujia	34.00
22	41411741740V	Blocchetto / Little stop / Kleiner Stopper / Petit stop / Tope pequeno	32.00
23	41451406501	Ventilatore fumi / Smoke exhausted fan / Rauchgasgebläse / Ventilateur fumées / Ventilador humos	109.00
23	41801102500	Guarnizione / Gasket / Dichtung / Joint / Junta	21.00
23	41451209300	Encoder per ventilatore fumi marchi LN2/SIT / Encoder for LN2/SIT smoke fan / Encoder für LN2/SIT Rauchgasgebläse / Encoder pour ventilateur des fumées marques LN2/SIT / Encoder para ventilador humos marcas LN2/SIT	21.00
23	41452009200	Encoder ventilatore / Fan encoder / Lüfter Encoder / Encodeur de ventilateur / Codificador de ventilador	17.00
24	41801002600	Guarnizione adesiva voluta fumi / Adhesive gasket smoke volute / Haftendichtung Rauchvolute / Joint adhesive volute fumées / Junta adhesiva voluta humos	20.00
24	41801599850	Kit 50 guarnizioni / Kit 50 gaskets / Bausatz 50 Dichtungen / Kit 50 joints / Kit 50 juntas	800.00
25	41451702300	Ventilatore tangenziale / Warm air fan / Luftgebläse / Ventilateur air / Ventilador aire	59.00
26	41451801600	Cavo flat 20 vie L.600 mm / Flat cable 20 pin L.600 mm / Flat-Kabel 20polig L.600 mm / Cable flat 20 voies L.600 mm / Flat cable 20 vias L.600 mm	24.00
27	41451602802	Pannello di emergenza Wireless / Wireless emergency display / Wireless Notfall-Blende / Panneau d'urgence wireless / Panel emergencia wireless	100.00
28	41451403200	Cavo USB da pannello L.500 / USB Cable from display L.500 / USB Kabel von Notfalldisplay L.500 / Câble USB de panneau L.500 / Cable USB del panel L.500	21.00
29	41451503300	Ventilatore centrifugo / Air fun / Lufgebläse / Vantilateur air / Ventilador aire	76.00
29	41451503300	Ventilatore centrifugo / Air fun / Lufgebläse / Vantilateur air / Ventilador aire	76.00
30	41801601600	Guarnizione ventilatore / Fan gasket / Dichtung des Gebläses / Joint du ventilateur / Junta ventilador	17.00
30	41801601600	Guarnizione ventilatore / Fan gasket / Dichtung des Gebläses / Joint du ventilateur / Junta ventilador	17.00
31	41451702400	Cablaggio elettrico / Electrical wiring / Elektrische Verkabelung / Câblage électrique / Cableado eléctrico	63.00
32	412007004	Clickson 110°C / Clickson 110°C / Clickson 110°C / Clickson 110°C / Clickson 110°C	20.00
33	4020006	Telecomando / Remote control / Fernbedienung / Télécommande / Mando a distancia	98.00
33	4017014	Sensore temperatura Wireless / temperature sensor Wireless / Temperaturfühler Wireless / Capteur de Temperatur Wiresless / Sensor de temperatura Wireless	-
34	41451703600	Sonda fumi con flangia con morsetti L.980 / Smoke sensor with flange with terminal board L.980 / Rauchsonde mit Flansche mit Klemmbrett L.980 / Sonde fumées avec bride avec serre-câble L.980 / Sonda humos con brida con borne L.980	23.00