

MCZ GROUP

KLIN - 2016

Componenti Struttura Esterna / External structure components / Bauteile Aussenkorpus / Composants structure externe / Componentes estructura externa

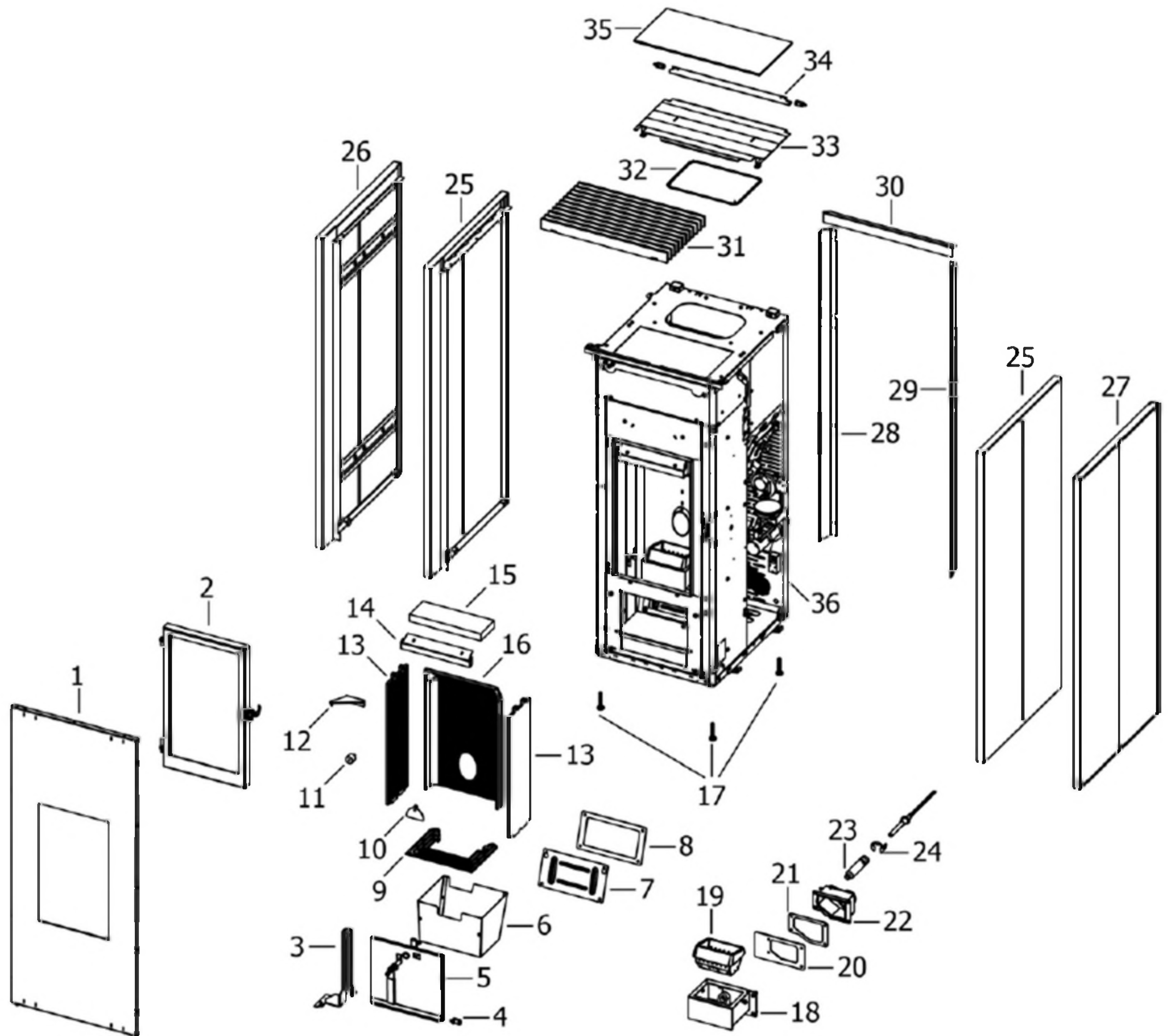

KLIN - 2016

Componenti Struttura Esterna / External structure components / Bauteile Aussenkorpus / Composants structure externe / Componentes estructura externa

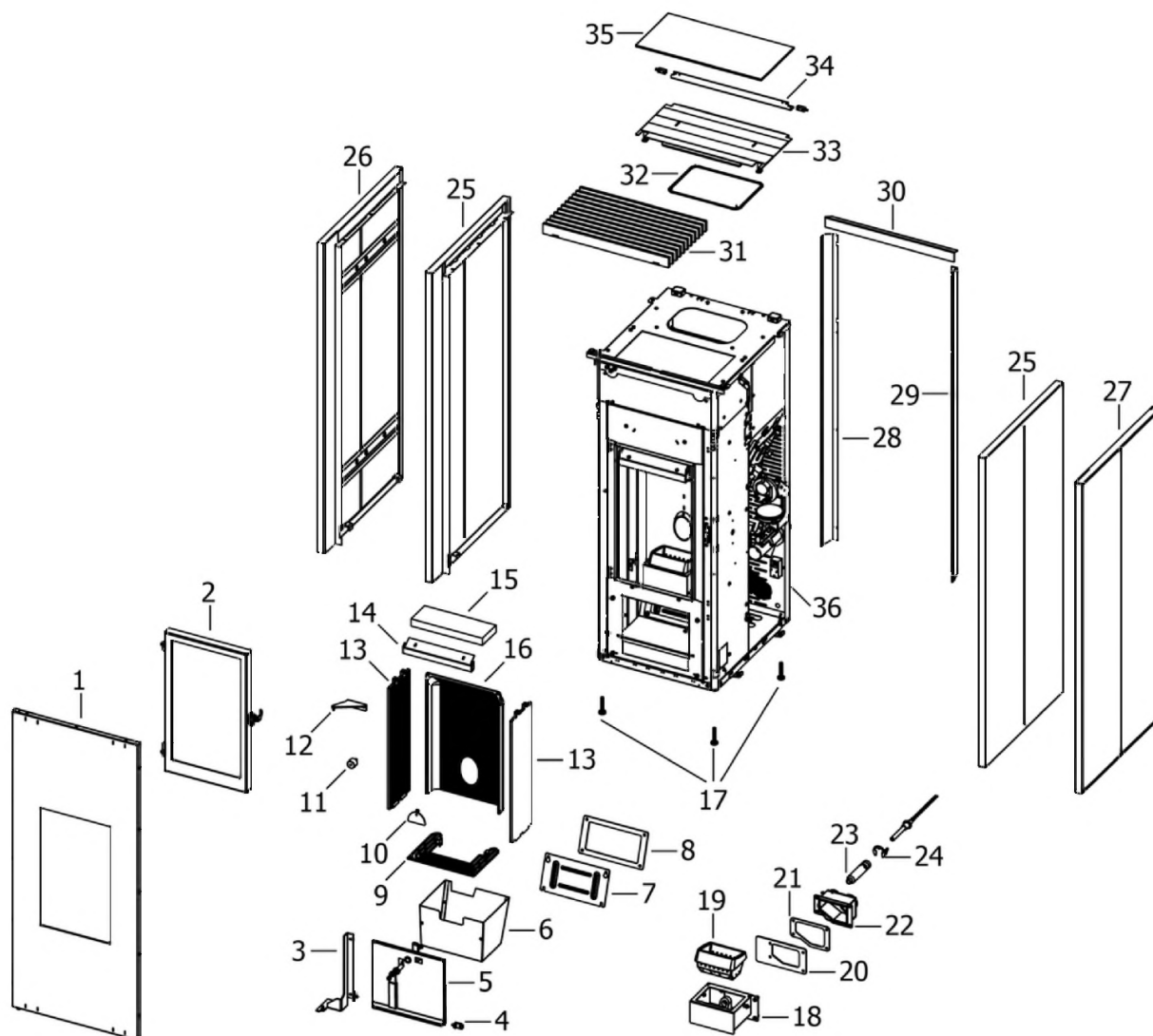

N°	Codice/Code	Descrizioni / Description / Beschreibung / Description / Description	Prezzo (€)
1	41421708350	Porta estetica / Aesthetic door / Außentür / Porte esthétique / Puerta estética	495.00
2	437016055	Porta focolare in lamiera / Metal sheet fire door / Feuerstelle Tür / Porte foyer / Puerta hogar	297.00
2	437017082	Porta fuoco in ghisa / Cast iron fireplace door / Feuertür aus Gusseisen / Porte foyer en fonte / Puerta hogar de arrabio	208.00
3	41411670440V	Cerniera tappo inferiore / Hinge for lower cap / Scharnier für unteren Stöpsel / Charnière pour bouchon inférieur / Bisagra por tapa inferior	34.00
4	41411623740V	Cerniera acciaio porta cenere / Ash compartment door steel hinge / Aschenklappe Stahlscharnier / Charnier en acier porte compartiment cendre / Bisagra en acero puerta compartimento cenizas	23.00
5	437016130	Porta cenere con maniglia / Ash drawer door with handle / Tür des Aschenkastens mit Griff / Porte tiroir à cendres avec poignée / Puerta cajón ceniza con tirador	83.00
5	41421602141V	Porta cenere / Ash drawer door / Tür des Aschenkastens / Porte tiroir à cendres / Puerta cajón ceniza	57.00
5	4120104A	Cordino fibroceramico Ø 12 mm (5 mt.) / Ceramic fibre cord Ø 12 mm (5 m.) / Keramikfaserschnur Ø 12 mm (5 m) / Cordon en fibre céramique Ø 12 mm (5 m) / Junta a cuerda de fibra cerámica Ø 12 mm (5 m)	36.00
5	4120104B	Cordino fibroceramico Ø 12 mm (50 mt.) / Ceramic fibre cord Ø 12 mm (50 m.) / Keramikfaserschnur Ø 12 mm (50 m) / Cordon en fibre céramique Ø 12 mm (50 m) / Junta a cuerda de fibra cerámica Ø 10 mm (52 m)	210.00
5	41201041	Kit sostituzione cordino (cordino+silicone) Ø 12 mm / Cord replacement kit (cord + silicone) Ø 12 mm / Schnuraustauschsatz (Schnur+Silikon) Ø 12 mm / Kit remplacement cordon (cordon + silicone) Ø 12 mm / Kit sustitución junta a cuerda (junta a cuerda+silicón) Ø 12 mm	50.00

5	41411621600	Maniglia con impugnatura porta cenere / Handle / Griff / Poignée / Tirador	20.00
6	437016041	Cassetto cenere / Ash drawer / Aschenkasten / Tiroir à cendres / Cajón ceniza	56.00
7	41401339610	Tappo ispezione vano fumi / Smoke compartment inspection plug / Inspektionsdeckel Rauchabzug / Clapet inspection compartiment fumées / Tapón inspección compartimento humos	21.00
8	41800900600	Guarnizione / Gasket / Dichtung / Joint / Junta	21.00
8	41801599750	Kit 50 guarnizioni / Kit 50 gaskets / Bausatz 50 Dichtungen / Kit 50 joints / Kit 50 juntas	840.00
9	41411634830V	Griglia focolare / Fire Box Grille / Feuerstellenrost / Grille Foyer / Rejilla Hogar	29.00
10	41411613530V	Deflettore pellet / Pellet deflector / Pellet Leitblech / Deflecteur pellet / Deflector pellet	23.00
11	41801657900	Magneti (pz.2) / Magnet (pcs.2) / Magnet (stk. 2) / Aimant (pcs.2) / Imán (pz.2)	22.00
12	41411670740V	Cerniera superiore / Higher hinge / Oberes Scharnier / Charnière supérieur / Bisagra superior	21.00
13	41301502500V	Fianco ghisa / Cast iron side / Seite aus Guß / Côté en fonte / Placa lateral de arrabio	49.00
13	41301502500V	Fianco ghisa / Cast iron side / Seite aus Guß / Côté en fonte / Placa lateral de arrabio	49.00
14	41411615430V	Deflettore aria / Air deflector / Luftleitblech / Déflecteur aire / Deflector aire	26.00
15	41151600200	Deflettore focolare in vermiculite / Vermiculite deflector / Leitblech aus Vermiculite / Déflecteur en vermiculite / Deflector en vermiculite	22.00
16	41301502600V	Schiena ghisa / Cast iron back / Rückwand aus Gusseisen / Dosseret en fonte / Parte trasera en arrabio	71.00
17	41200906660	Piedini di appoggio (4 pz.) / Support feet (4 pcs.) / Einstellfüße (4 Stck.) / Vérins d'appui (4 p.es) / Pies de apoyo (4 piezas)	19.00
18	41411613140V	Tasca braciere / Combustion pot container / Brenntopfkasten / Récipient brasero / Contenedor brasero	79.00
18	41501701599	Manicotto potenziamento accensione / Combustion air extension pipe / Zusatzrohr für Nachrüstung / Tuyau amélioration allumage / Tubo impulso de encendido	26.00
19	41301502400V	Braciere ghisa / Cast iron grate / Brenntopf aus Gusseisen / Brasero en fonte / Brasero en arrabio	51.00
20	41801601500	Guarnizione tasca braciere / Combustion pot container gasket / Brenntopfkasten Dichtung / Joint récipient brasero / Junta contenedor brasero	18.00
21	41801602300	Guarnizione codolo / Gasket / Dichtung / Joint / Junta	19.00
22	41311600100	Codolo / Tool chuck / Einspannschaft / Outil d'emmanchement / Mango	29.00
23	41601601000	Condotto candeletta / Sparkplug Conduit / Zündkerzenkanal / Conduit Bougie / Conducto Bujia	27.00
23	41501701599	Manicotto potenziamento accensione / Combustion air extension pipe / Zusatzrohr für Nachrüstung / Tuyau amélioration allumage / Tubo impulso de encendido	26.00
24	41201601500	Anello arresto candeletta / Sparkplug stop / Zündkerzestopper / Butée bougie / Tope bujia	24.00
25	6915010	Rivestimento completo Metal Black / Metal Black complete cladding / Metal Black komplette Verkleidung / Habillage complet Metal Black / Revestimiento completo Metal Black	245.00
25	6915011	Rivestimento Serpentino / Serpentine cladding / Serpentin Verkleidung / Habillage Serpentino / Revestimiento de Serpentino	1,095.00
25	6915010	Rivestimento completo Metal Black / Metal Black complete cladding / Metal Black komplette Verkleidung / Habillage complet Metal Black / Revestimiento completo Metal Black	245.00
25	6915011	Rivestimento Serpentino / Serpentine cladding / Serpentin Verkleidung / Habillage Serpentino / Revestimiento de Serpentino	1,095.00
26	6915010	Rivestimento completo Metal Black / Metal Black complete cladding / Metal Black komplette Verkleidung / Habillage complet Metal Black / Revestimiento completo Metal Black	245.00
26	6915011	Rivestimento Serpentino / Serpentine cladding / Serpentin Verkleidung / Habillage Serpentino / Revestimiento de Serpentino	1,095.00
27	6915010	Rivestimento completo Metal Black / Metal Black complete cladding / Metal Black komplette Verkleidung / Habillage complet Metal Black / Revestimiento completo Metal Black	245.00
27	6915011	Rivestimento Serpentino / Serpentine cladding / Serpentin Verkleidung / Habillage Serpentino / Revestimiento de Serpentino	1,095.00
28	41411671631P	Cornice posteriore sinistra nera / Black left rear frame / Schwarze linke Unterblende / Encadrement noir posterieur gauche / Marco posterior negro izquierdo	33.00
29	41411671531P	Cornice posteriore destra nera / Black right rear frame / Schwarze rechte Unterblende / Encadrement noir posterieur droite / Marco posterior negro derecho	33.00
30	41411671730P	Cornice superiore nera / Black upper frame / Schwarze Oberblende / Panneau antérieur supérieur noir / Frontal superior negro	23.00
31	41411671041P	Griglia aria nera / Black air grille / Schwarze Luftgitter / Grille air noire / Rejilla aire negra	348.00
32	41801504700	Guarnizione tenuta serbatoio / Pellet hopper gasket / Pelletbehälter Dichtung / Joint réservoir pellet / Junta deposito pellet	21.00
33	41411503230P	Coperchio serbatoio pellet con vetro / Pellet hopper cover with glass / Deckel Pelletbehälter mit Glass / Couvercle réservoir pellet avec vitre / Tapadera deposito con cristal	143.00

34	41411671430V	Supporto coperchio serbatoio / Pellet hopper support / Halterung für Deckel Pelletbehälter / Support pour couvercle réservoir / Soporte por tapadera depósito	36.00
35	41701500260	Vetro temprato serigr. coperchio serbatoio / Tempered glass hopper cover / Vorgespanntes Glass Deckel Pelletbehälter / Verre trempé couvercle reservoir / Vidrio templado tapa depósito	71.00
36	41401702332	Kit schiena con supporto scheda / Kit for rear back with supports for board / Rückwand Kit mit Halterungen für Platine / Kit dos avec supports pour carte / Kit espalda con soporte por tarjeta	80.00

MCZ GROUP

KLIN - 2016

Porta fuoco / Fire door / Feuertür / Porte foyer / Puerta hogar

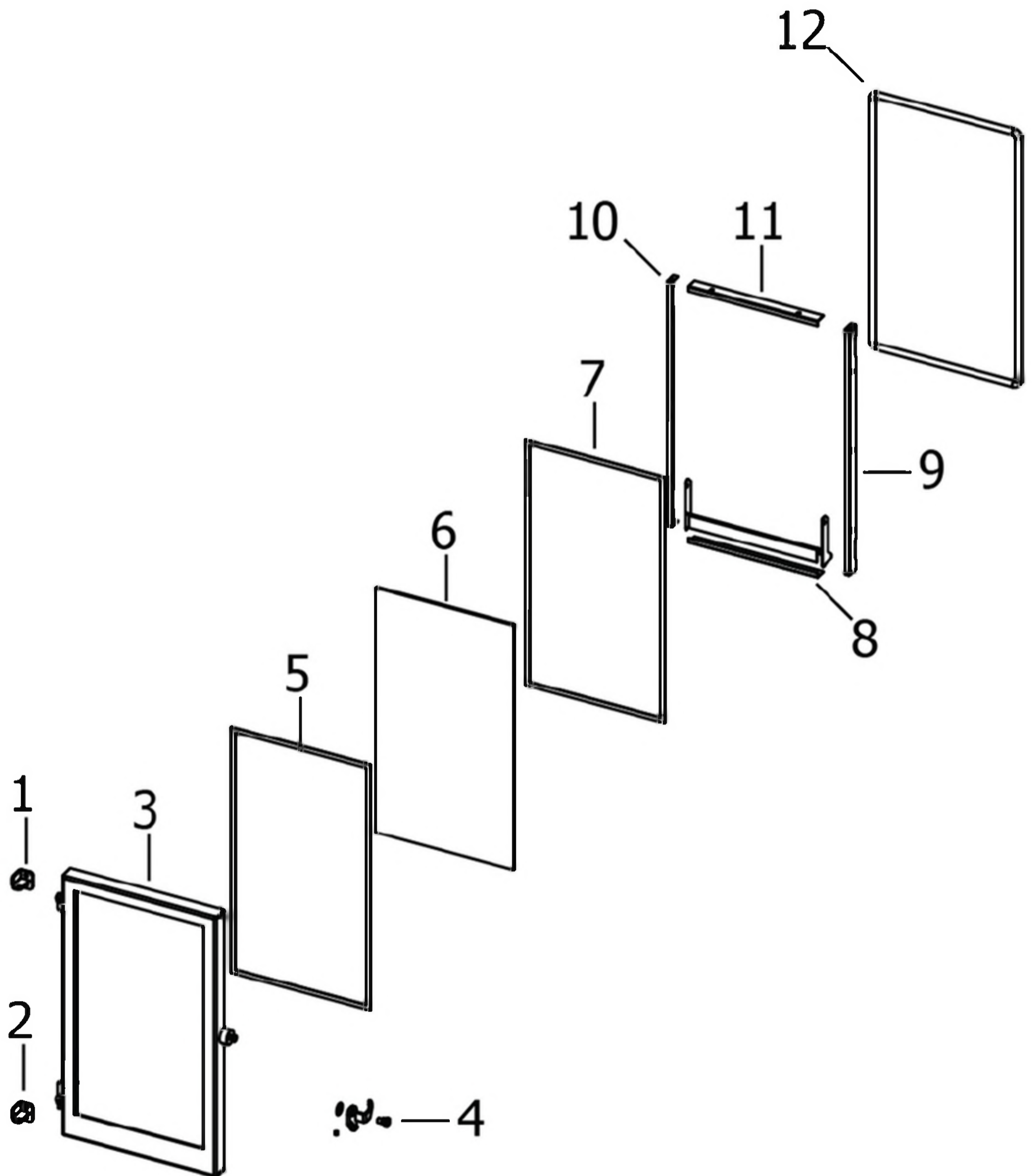

KLIN - 2016

Porta fuoco / Fire door / Feuertür / Porte foyer / Puerta hogar

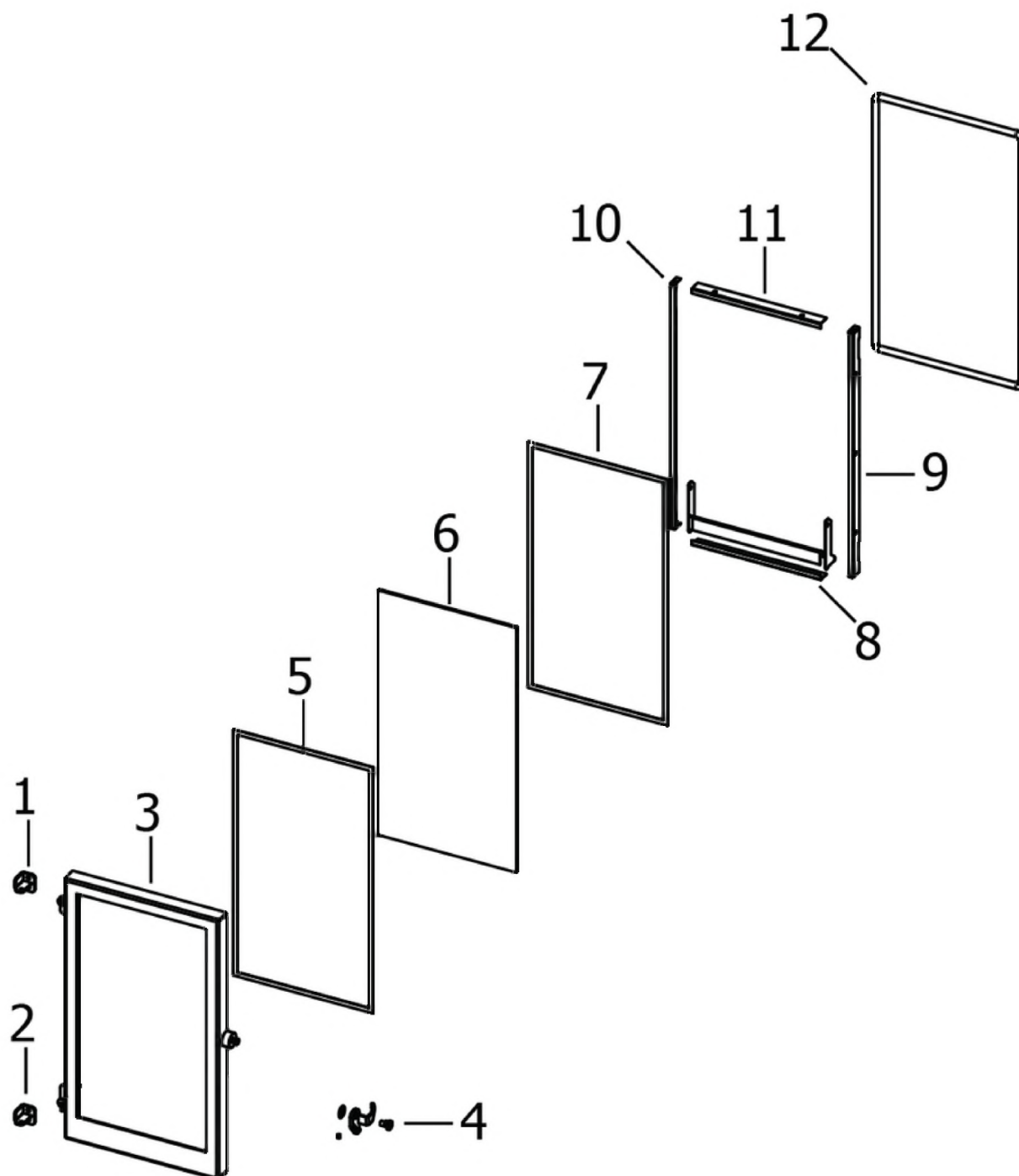

N°	Codice/Code	Descrizioni / Description / Beschreibung / Description / Descripción	Prezzo (€)
1	41411664730V	Cerniera porta / Door hinge / Türgriff / Charnière porte / Bisagra puerta	21.00
1	41411738140V	Cerniera sup.porta ghisa / Upper hinge for cast iron door / Obere Scharnier für Tür aus Guß / Charnière supérieur pour porte en fonte / Bisagra superior por porta en arrabio	23.00
2	41411738040V	Cerniera inf.porta ghisa / Lower hinge for cast iron door / Unterer Scharnier für Tür aus Guß / Charnière inférieur pour porte en fonte / Bisagra inferior por porta en arrabio	23.00
2	41411664730V	Cerniera porta / Door hinge / Türgriff / Charnière porte / Bisagra puerta	21.00
3	41421600941V	Telaio porta fuoco / Fire door frame / Feuertürrahmen / Cadre porte foyer / Armazón puerta de arrabio	86.00
3	41301602500V	Telaio porta fuoco / Fire door frame / Feuertürrahmen / Cadre porte foyer / Armazón puerta de arrabio	78.00

4	41411616560	Maniglia porta nera / Door Handle / Türgriff / Poignée porte / Tirador	27.00
5	4120573A	Guarnizione a nastro 8 mm (5 mt.) per porta / Door strip gasket 8 mm (5 m) / Türbanddichtung 8 mm (5 m) / Joint ruban 8 mm (5 m) pour porte / Guarnición de cinta para puerta 8 mm (5 m)	32.00
5	4120573B	Guarnizione a nastro 8 mm (50 mt.) per porta / Door strip gasket 8 mm (50 m) / Türbanddichtung 8 mm (50 m) / Joint ruban 8 mm (50 m) pour porte / Guarnición de cinta para puerta 8 mm (50 m)	162.00
5	41801603300A	Guarnizione Ø5 5mt / Gasket Ø5 5mt / Dichtung Ø5 5mt / Joint Ø5 5mt / Junta Ø5 5mt	42.00
5	41801603300B	Guarnizione Ø5 50mt / Gasket Ø5 50mt / Dichtung Ø5 50mt / Joint Ø5 50mt / Junta Ø5 50mt	299.00
5	41801603300C	Guarnizione Ø5 5mt + silicone / Gasket Ø5 5mt + silic / Dichtung Ø5 5mt + Silikon / Joint Ø5 5mt + silic / Junta Ø5 5mt	63.00
6	41701600200	Vetroceramico / Glass / Glaskeramikscheibe / Vitrocéramique / Cristal cerámico	90.00
6	41701600300	Vetroceramico porta ghisa / Cast iron door glass / Glaskeramikscheibe Tür aus Gusseise / Vitrocéramique porte en fonte / Cristal cerámico puerta en arrabio	79.00
7	4120573A	Guarnizione a nastro 8 mm (5 mt.) per porta / Door strip gasket 8 mm (5 m) / Türbanddichtung 8 mm (5 m) / Joint ruban 8 mm (5 m) pour porte / Guarnición de cinta para puerta 8 mm (5 m)	32.00
7	4120573B	Guarnizione a nastro 8 mm (50 mt.) per porta / Door strip gasket 8 mm (50 m) / Türbanddichtung 8 mm (50 m) / Joint ruban 8 mm (50 m) pour porte / Guarnición de cinta para puerta 8 mm (50 m)	162.00
8	41411616430V	Deflettore inferiore porta nero / Lower black door deflector / Unterer schwarze Leitblech der Tür / Deflecteur inférieur noir de la porte / Deflector negro inferior de la puerta	27.00
8	41411622130V	Scivolo cenere / Ash ramp / Aschenrutsche / Glissèrie cendre / Tobogán ceniza	37.00
9	41401610630	Fermavetro destro/sinistro Porta / Right/Left glass fastening bracket door / Rechte/Linke Haltebügel für Tür / Droit/Gauche etrier de fixation vitrocéramique - porte / Retendor derecho/izquierdo del cristal - puerta	27.00
9	41411622030V	Profilo fermavetro / Fastening bracket profile / Haltebügel für Scheibebefestigung Profil / Profil patte de fixation / Perfil fermacristal	37.00
10	41401610630	Fermavetro destro/sinistro Porta / Right/Left glass fastening bracket door / Rechte/Linke Haltebügel für Tür / Droit/Gauche etrier de fixation vitrocéramique - porte / Retendor derecho/izquierdo del cristal - puerta	27.00
10	41411622030V	Profilo fermavetro / Fastening bracket profile / Haltebügel für Scheibebefestigung Profil / Profil patte de fixation / Perfil fermacristal	37.00
11	41411615430V	Deflettore aria / Air deflector / Luftleitblech / Défecteur aire / Deflector aire	26.00
12	4120104A	Cordino fibroceramico Ø 12 mm (5 mt.) / Ceramic fibre cord Ø 12 mm (5 m.) / Keramikfaserschnur Ø 12 mm (5 m) / Cordon en fibre céramique Ø 12 mm (5 m) / Junta a cuerda de fibra cerámica Ø 12 mm (5 m)	36.00
12	4120104B	Cordino fibroceramico Ø 12 mm (50 mt.) / Ceramic fibre cord Ø 12 mm (50 m.) / Keramikfaserschnur Ø 12 mm (50 m) / Cordon en fibre céramique Ø 12 mm (50 m) / Junta a cuerda de fibra cerámica Ø 10 mm (52 m)	210.00
12	41201041	Kit sostituzione cordino (cordino+silicone) Ø 12 mm / Cord replacement kit (cord + silicon) Ø 12 mm / Schnuraustauschsatz (Schnur+Silikon) Ø 12 mm / Kit remplacement cordon (cordon + silicone) Ø 12 mm / Kit sustitución junta a cuerda (junta a cuerda+silicón) Ø 12 mm	50.00

KLIN - 2016

Porta estetica / Aesthetic door / Aesthetische Tür / Porte esthétique / Puerta estética

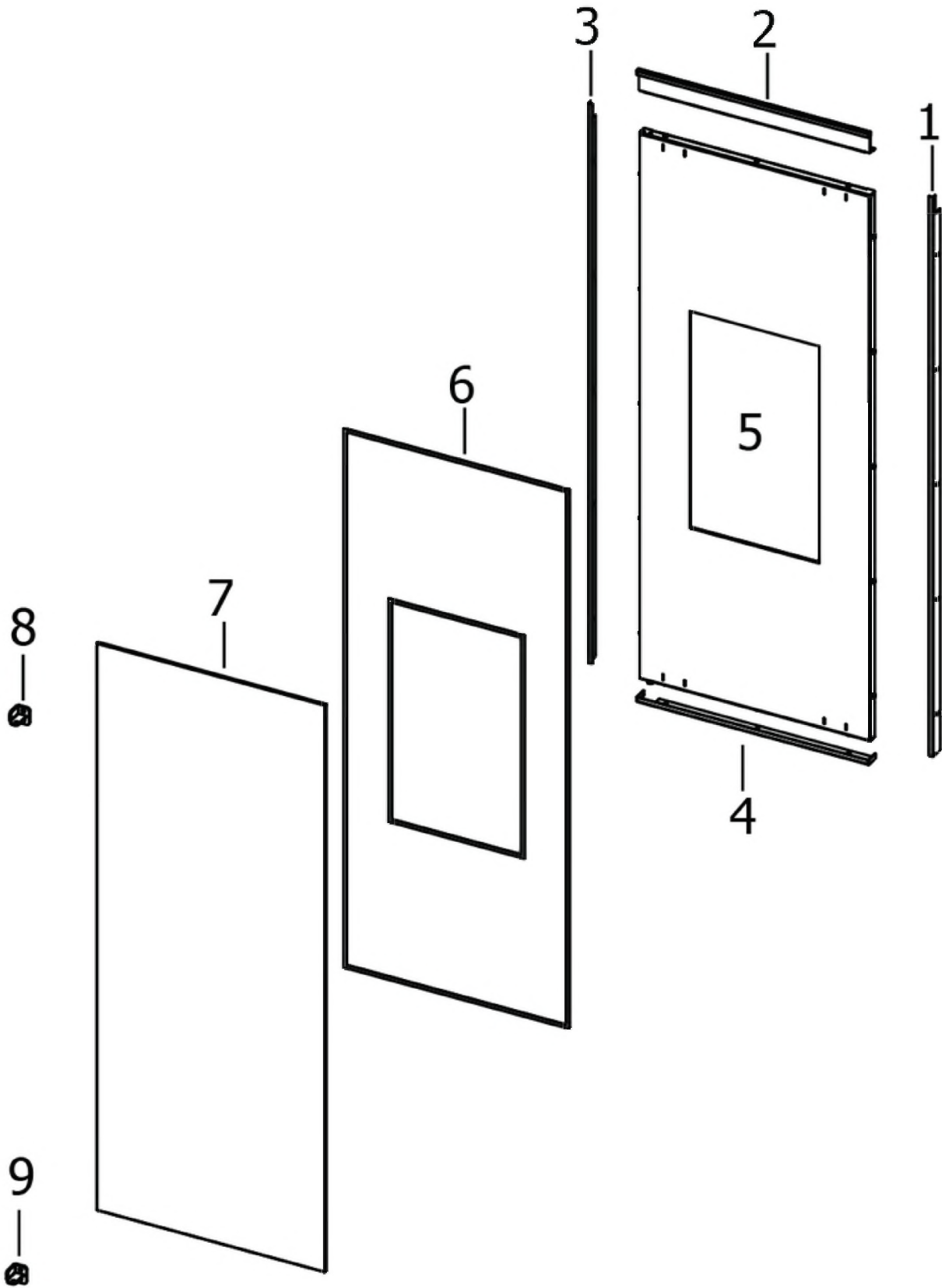

N°

Codice/Code

Descrizioni / Description / Beschreibung / Description / Descripción

Prezzo (€)

1	41411502530P	Fermavetro DX - porta esterna / R. glass fastening bracket - External door / R. Haltebügel für Scheibebefestigung - Außentür / Etrier D. de fixation vitrocéramique - porte extérieure / Retendor DCHO del cristal - Puerta exterior	46.00
2	41411502730P	Fermavetro superiore - porta esterna / Upper glass fastening bracket - External door / Oberes Haltebügel für Scheibebefestigung - Außentür / Etrier de fixation supérieur vitrocéramique - porte extérieur / Retendor superior del cristal - Puerta exterior	25.00
3	41411502630P	Fermavetro SX - porta esterna / L. glass fastening bracket - External door / L. Haltebügel für Scheibebefestigung - Außentür / Etrier G. de fixation vitrocéramique - porte extérieure / Retendor IZDO del cristal - Puerta exterior	45.00
4	41411502430P	Fermavetro inferiore - porta esterna / Lower glass fastening bracket - External door / Unteres Haltebügel für Scheibebefestigung - Außentür / Etrier de fixation inférieur vitrocéramique - porte extérieur / Retendor inferior del cristal - Puerta exterior	37.00
5	41421606540V	Porta estetica / Aesthetic door / Außentür / Porte esthétique / Puerta estética	285.00
6	4120572A	Guarnizione a nastro 6 mm (5 mt.) per porta / Door strip gasket 6 mm (5 m) / Türbanddichtung 6 mm (5 m) / Joint ruban 6 mm (5 m) pour porte / Guarnición de cinta para puerta 6 mm (5 m)	33.00
6	4120572B	Guarnizione a nastro 6 mm (50 mt.) per porta / Door strip gasket 6 mm (50 m) / Türbanddichtung 6 mm (50 m) / Joint ruban 6 mm (50 m) pour porte / Guarnición de cinta para puerta 6 mm (50 m)	210.00
7	41701600460	Vetroceramico con serigrafia / Glass / Glaskeramikscheibe / Vitrocéramique / Cristal cerámico	281.00
8	41411670740V	Cerniera superiore / Higher hinge / Oberes Scharnier / Charnière supérieur / Bisagra superior	21.00
9	41411670440V	Cerniera tappo inferiore / Hinge for lower cap / Scharnier für unteren Stöpsel / Charnière pour bouchon inférieur / Bisagra por tapa inferior	34.00

MCZ GROUP

KLIN - 2016

Componenti interni meccanici ed elettronici / Electronic and mechanic internal parts / Interne mechanische und elektronische Bauteile / Composants internes mécaniques et électroniques / Componentes internos electrónicos y mecánicos

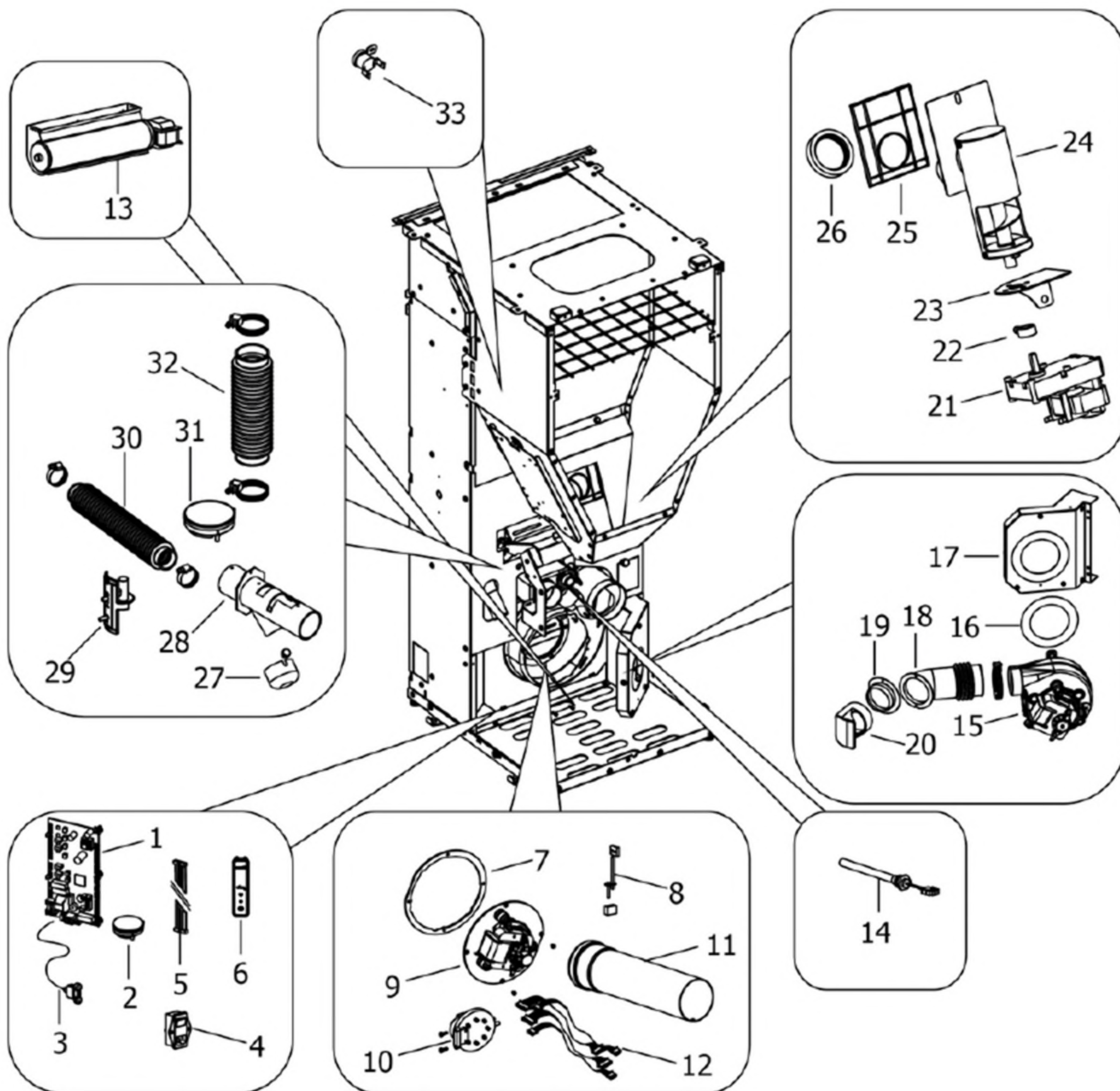

KLIN - 2016

Componenti interni meccanici ed elettronici / Electronic and mechanic internal parts / Interne mechanische und elektronische Bauteile / Composants internes mécaniques et électroniques / Componentes internos electrónicos y mecánicos

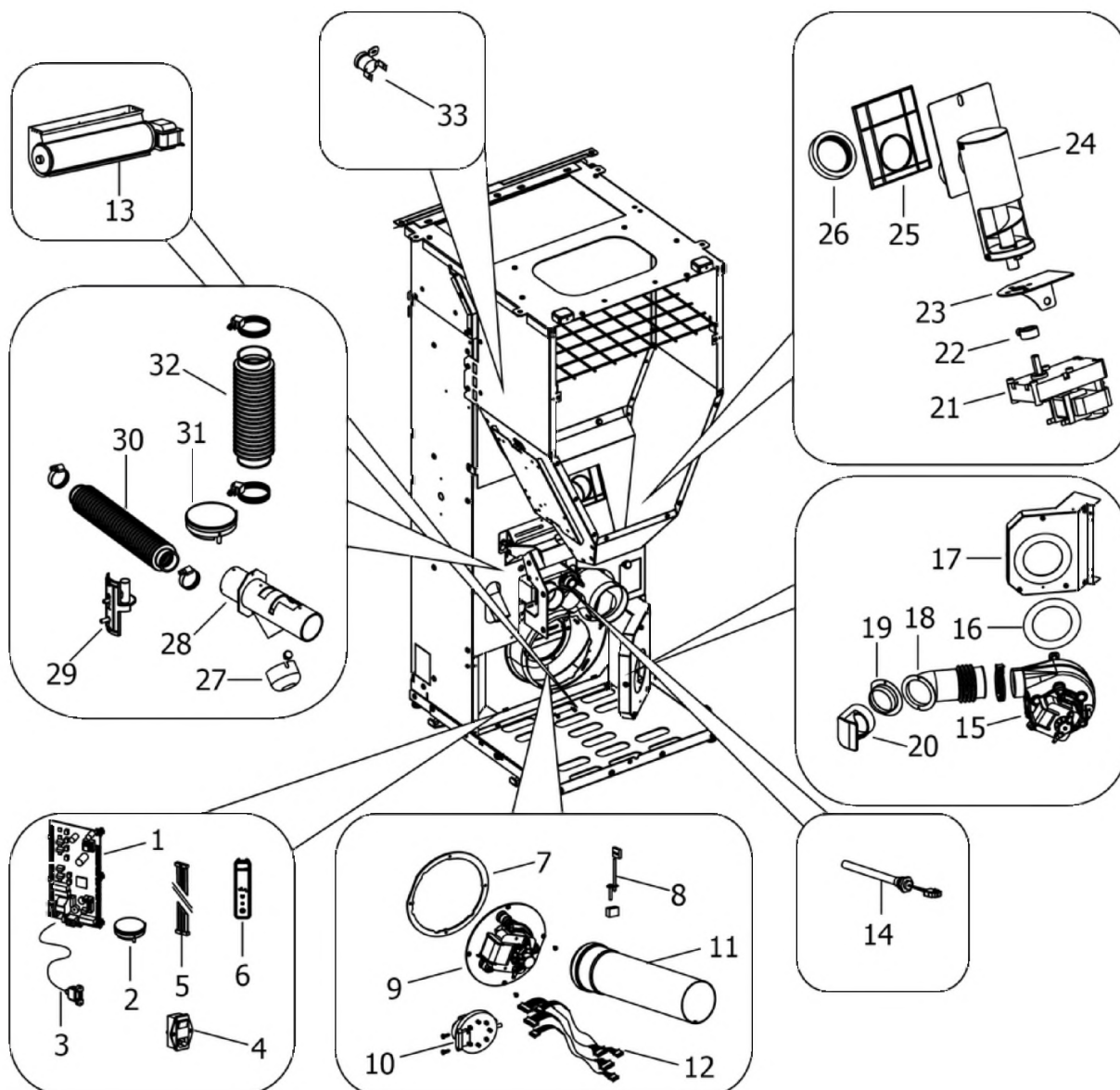

N°	Codice/Code	Descrizioni / Description / Beschreibung / Description / Descripción	Prezzo (€)
1	41451602602	Scheda elettronica plus / Electronix mother board plus / Elektronische Platine Plus / Carte mère électronique plus / Tarjeta madre electronica plus	191.00
2	4020006	Telecomando / Remote control / Fernbedienung / Télécommande / Mando a distancia	98.00
2	4017014	Sensore temperatura Wireless / temperature sensor Wireless / Temperaturfühler Wireless / Capteur de Temperatur Wireles / Sensor de temperatura Wireless	-
3	41451403200	Cavo USB da pannello L.500 / USB Cable from display L.500 / USB Kabel von Notfalldisplay L.500 / Câble USB de panneau L.500 / Cable USB del panel L.500	21.00
4	4160193	Pulsante accensione / On/Off button / Zündungstaste / Touche d'allumage / Botón encendido	28.00
5	41451801600	Cavo flat 20 vie L.600 mm / Flat cable 20 pin L.600 mm / Flat-Kabel 20polig L.600 mm / Cable flat 20 voies L.600 mm / Flat cable 20 vias L.600 mm	24.00
6	41451602802	Pannello di emergenza Wireless / Wireless emergency display / Wireless Notfall-Blende / Panneau d'urgence wireless / Panel emergencia wireless	100.00
7	41801600800	Guarnizione ventilatore fumi / Smoke exhaust fan gasket / Dichtung Rauchabsauggebläse / Joint Ventilateur aspiration fumées / Junta ventilador aspiración humos	22.00

8	41451703600	Sonda fumi con flangia con morsettiera L.980 / Smoke sensor with flange with terminal board L.980 / Rauchsonde mit Flansche mit Klemmenbrett L.980 / Sonde fumées avec bride avec serre-câble L.980 / Sonda humos con brida con borne L.980	23.00
9	41451503200	Ventilatore fumi stagno / Air-tight smoke exhausted fan / Luftdichtes Rauchgasgebläse / Ventilateur fumées étanche / Ventilador humos hermético	82.00
9	41451703000	Encoder per ventilatore fumi marchio EBM / Encoder for EMB smoke fan / Encoder für EBM Rauchgasgebläse / Encoder pour ventilateur des fumées marque EBM / Encoder para ventilador humos marca EBM	22.00
9	41451209300	Encoder per ventilatore fumi marchi LN2/SIT / Encoder for LN2/SIT smoke fan / Encoder für LN2/SIT Rauchgasgebläse / Encoder pour ventilateur des fumées marques LN2/SIT / Encoder para ventilador humos marcas LN2/SIT	21.00
9	41452009200	Encoder ventilatore / Fan encoder / Lüfter Encoder / Encodeur de ventilateur / Codificador de ventilador	17.00
10	41451003700	Pressostato / Pressure switch / Druckschalter / Pressostat / Presostato	40.00
11	41601604560	Tubo fumi Ø 80 con guarnizione / Smoke pipe Ø 80 with gasket / Rauchrohr Ø 80 mit Dichtung / Tuyau fumées Ø 80 avec joint / Tubo humos Ø 80 con junta	30.00
12	41451603701	Cablaggio elettrico base maestro / Basic electrical wiring maestro / Elektrische Verkabelung Maestro / Câblage électrique Maestro / Cableado eléctrico Maestro	62.00
13	41451600800	Ventilatore aria / Air fan / Luftgebläse / Ventilateur air / Ventilador aire	76.00
14	41451308101	Candeletta 315 Watt / Sparkplug 315 Watt / Zündkerze 315 Watt / Bougie 315 Watt / Bujia 315 Watt	77.00
14	41451308150	Kit 25 candelette 315 Watt / 25 Sparkplugs 315 Watt kit / Bausatz 25 Zündkerzen 315 Watt / Kit 25 Bougies 315 Watt / Kit 25 Bujias 315 Watt	1,637.00
15	41451503300	Ventilatore centrifugo / Air fan / Lufgebläse / Ventilateur air / Ventilador aire	76.00
16	41801601600	Guarnizione ventilatore / Fan gasket / Dichtung des Gebläses / Joint du ventilateur / Junta ventilador	17.00
17	41401624731	Convogliatore C/Air / Conveyor C/Air / Blech C/Air / Convoyeur C/Air / Conductor C/Air	46.00
18	41801601100	Tubo uscita aria silicone / Outlet air tube in silicone / Luftausgangrohr aus Silikon / Tuyau de sortie air en silicone / Tubo de salida aire en silicona	23.00
19	41600900460	Flangia Ø 60 / Flange Ø 60 / Flansch Ø 60 / Bride Ø 60 / Brida Ø 60	21.00
20	41801605300	Bocchetta posteriore in silicone / Silicone rear air outlet / Luftauslass aus Silikon / Diffuseur air en silicone / Boquilla aire en silicona	24.00
21	41451503100	Motoriduttore 2rpm / Gear motor 2rpm / Getriebemotor 2rpm / Motorréducteur 2rpm / Motorreductor 2rpm	102.00
22	4120398	Connettore motoriduttore-coclea / Reduction motor-feed screw connector / Verbindung Getriebemotor-Schnecke / Connecteur motorréducteur-vis sans fin / Conector motorreductor-cóclea	22.00
23	41401623830	base coclea pellet / Feed screw base for pellet / Untergestell der Förderschnecke für Pellet / Base de la vis sans fin granulés / Base de la cóclea pellets	29.00
24	41411800151	Gruppo alimentazione completo / Complete feed screw / Komplette Förderschnecke / Vis sans fin complète / Coclea de carga completa	113.00
25	41801600400	Guarnizione gruppo caricamento / Gasket / Dichtung / Joint / Junta	20.00
26	41801702600	Disaccoppiatore mesc. Marrone / Brown disengaging device / Braun Verängungrohr / Tuyau de découplage maron / Tubo de desvío marron	18.00
27	41401036100	Filtro antipolvere / Anti-dust filter / Staubschutzfilter / Filtre antipoussière / Filtro de protección polvo	21.00
28	41601604461	Tubo aspirazione / Air inlet pipe / Lufteingangrohr / Tuyau entrée d'air / Tubo entrada aire	42.00
29	41601301850	Componente rilevamento portata aria / Air flow measure component / Bauteil für Messung der Luftmenge / Composent pour la mesuration de la quantité d'air / Componente por la medida de l'aire	34.00
30	41801601900	Tubo aspirazione pulizia vetro / Inlet pipe for cleaning glass air / Glassreinigung Lufteingangrohr / Tuyau entrée pour l'aire de nettoyage du vitre / Tubo entrada por l'aire de limpieza vidrio	62.00
31	41451303400	Trasduttore di pressione / Pressure transducer / Active-Wandler / Transducteur de pression / Transductor de pression	58.00
31	4120631A	Tubicino silicónico - 5m / Silicon tube - 5m / Silikonrohr - 5m / Petit tuyau en silicone - 5m / Tubo silicónico - 5m	22.00
32	41801601700	Tubo aspirazione camera combustione / Combustion chamber aspiration tube / Verbrennungskammer Förderrohr / Tuyay aspiration air chambre de combustion / Tubo aspiración aire cámara de combustión	28.00
33	412007004	Clickson 110°C / Clickson 110°C / Clickson 110°C / Clickson 110°C / Clickson 110°C	20.00