

SELECTA 25 S1

Gruppo estetico / Aesthetic group / Aesthetische Gruppe / Groupe esthétique / Grupo estético

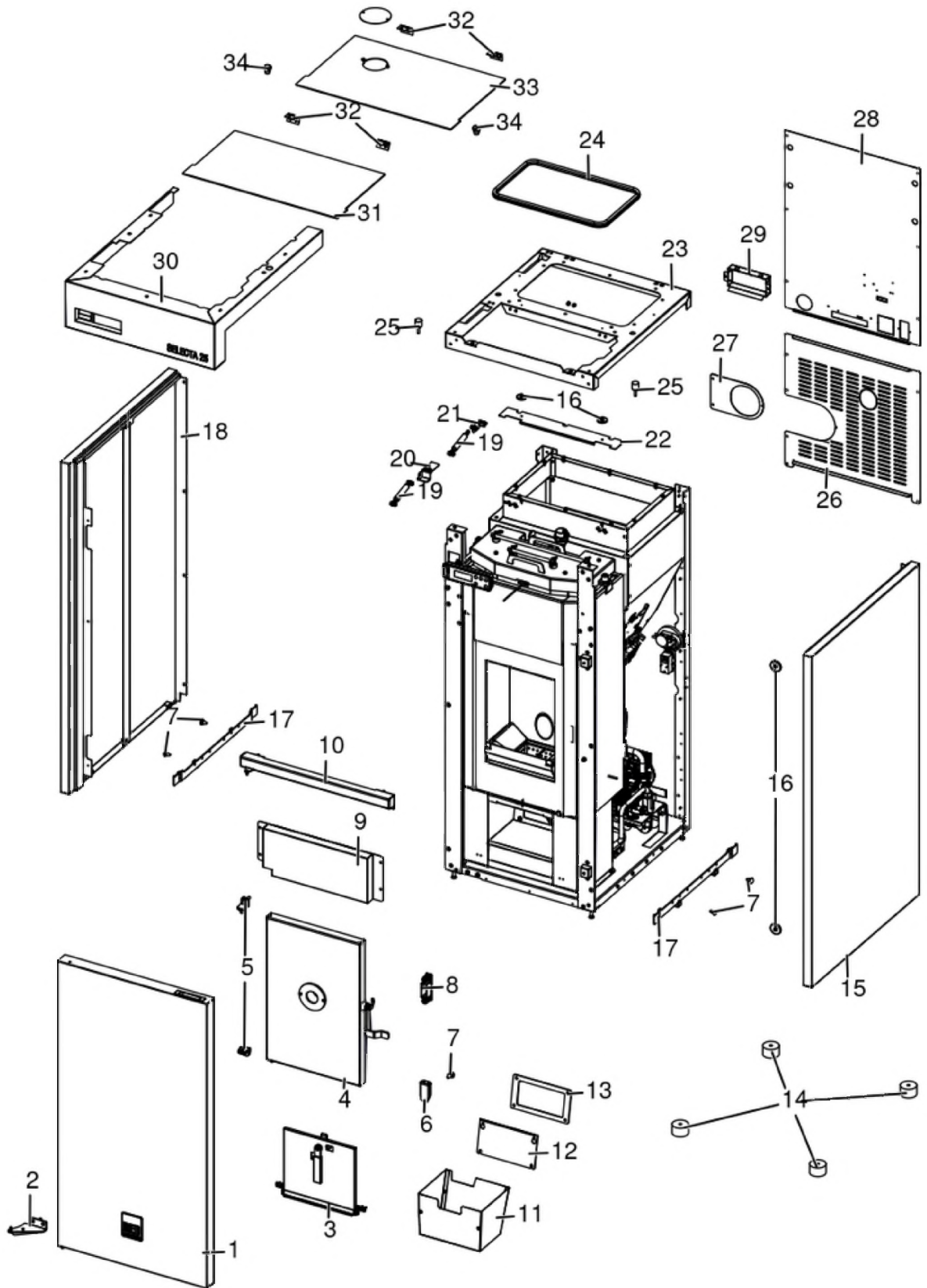

N°	Codice/Code	Descrizioni / Description / Beschreibung / Description / Descripcion	Prezzo (€)
1	41411754850	Porta estetica / Aesthetic door / ästhetische Tür / Porte esthétique / Puerta estética	209.00
2	4141175184000	Cerniera inferiore nera / Black lower hinge / Schwarzes unteres Scharnier / Charnière inférieure noir / Bisagra inferior negra	43.00
3	437016077	Porta cassetto cenere / Ash drawer door / Tür des Aschenkastens / Porte tiroir à cendres / Puerta cajón ceniza	124.00
4	41411753150	Porta focolare completa / Fireplace door / Feuerstelle Tür / Porte foyer / Puerta hogar	530.00
5	412008063	Cerniere porta fuoco (2 pz) / Fire door hinge (2pcs) / Scharnier Feuertür (2 Stck) / Charnière porte foyer (2 pcs) / bisagra puerta del hogar (2 pz)	27.00
6	41401831030	Staffa sicurezza porta cenere / Ash holder safety bracket / Aschentür Sicherheitsbügel / Support de sécurité pour porte-cendres / Soporte de seguridad porta cenizas	11.00
7	41801002300	Paracolpi in silicone Ø 8/5 (2pz) / Silicone bumpers Ø 8/5 (2pcs) / Schlagschutzgummi Ø 8/5 (2 Stck) / Pièces silicone antichoc Ø 8/5 (2pcs) / Anti-golpes en silicona Ø 8/5 (2pzs)	18.00
8	437016033	Gruppo chiusura porta focolare / Fire door closing group / Feuerraumtürschließgruppe / Groupe de fermeture de la porte du foyer / Grupo de cierre de la puerta del hogar	53.00
9	41401716950	Scudo frontale / Fireplace door cover / Feuerstelle Tür Abdeckung / Couverture porte foyer / Tapa puerta hogar	69.00
10	41411755040P	Cornice con cerniera / Frame with hinge / Rahmen mit Scharnier / Cadre avec charnière / Marco con bisagra	61.00
11	437016041	Cassetto cenere / Ash drawer / Aschenkasten / Tiroir à cendres / Cajón ceniza	56.00
12	41401605530	Tappo camera fumi zincato / Smoke compartment galvanized plug / Verzinktes Rauchabzugklappe / Join zingué compartiment fumées / Tapón galvanizado compartimento humos	20.00
13	41801601300	Guarnizione tappo camera fumi / Smoke compartment plug gasket / Dichtung Rauchabzugklappe / Joint clapet compartiment fumées / Junta tapón compartimento humos	19.00
14	41801400200	Piedini di appoggio (4 pz.) / Support feet (4 pcs.) / Einstellfüße (4 Stck.) / Vérins d'appui (4 p.es) / Pies de apoyo (4 piezas)	35.00
15	41401719150	Fianco estetico destro completo / Complete right aesthetic side / Vollständige rechte ästhetische Seite / Côté esthétique droit complet / Completo lado estético derecho	163.00
16	41801657900	Magneti (pz.2) / Magnet (pcs.2) / Magnet (stk. 2) / Aimant (pcs.2) / Imán (pz.2)	22.00
17	4141175173000	Aggancio inferiore fianco / Lower bracket for side / Untere Halterung für Seite / étrier inférieur coté / Soporte inferior lado	22.00
18	41401719350	Fianco estetico sinistro completo / Complete left aesthetic side / Komplette linke ästhetische Seite / Côté esthétique gauche complet / Lado estético izquierdo completo	163.00
19	41801101400	Pistone a gas / Gas-piston / Gas-Kolben / Piston à gaz / Piston a gas	45.00
20	41401716831	Staffa pistone posteriore / Rear piston bracket / Kolbenhalterung hinten / Support de piston arrière / Soporte piston trasero	16.00
21	41401716831	Staffa pistone posteriore / Rear piston bracket / Kolbenhalterung hinten / Support de piston arrière / Soporte piston trasero	16.00
22	41411753830P	Compensazione cornice superiore / Upper frame compensation / Oberrahmen Kompensations / Compensation de cadre supérieur / Compensación de marco superior	24.00
23	41401716631	Supporto top / Top support / Deckelhaltebügel / Support du dessus / Soporte top	71.00
24	41801208000	Guarnizione - 5 m / Gasket - 5 m / Dichtung - 5 m / Joint - 5 m / Junta - 5 m	141.00
24	41801208001	Guarnizione - 50 m / Gasket - 50 m / Dichtung - 50 m / Joint - 50 m / Junta - 50 m	1,277.00
24	41801208002	Guarnizione - 2,5 m / Gasket - 2,5 m / Dichtung - 2,5 m / Joint - 2,5 m / Junta - 2,5 m	83.00
25	41201501900	Antivibranti (10 pz) / Anti-vibration mountings (10 pcs) / Schwingungsdämpfer (10 Stck.) / Eléments antivibrations (10 pcs) / Anti-vibraciones (10 pzs)	22.00
26	41401718730	Pannello posteriore inferiore / Bottom rear panel / Untere Rückwand / Panneau arrière inférieur / Panel trasero inferior	58.00
27	41401803010	Supporto tubo fumi / Smoke pipe support / Rauchrohr Halterung / Support tuyau fumées / Soporte tubo humos	10.00
28	41401718631	Pannello posteriore superiore / Upper rear panel / Obere Rückwand / Panneau arrière supérieur / Panel trasero superior	38.00
29	41401620130	Coperchio morsetti 12 poli / 12-pole terminal block cover / 12-polige Klemmenblockabdeckung / Couvercle du bornier 12 pôles / Tapa del bloque de terminales de 12 polos	16.00
30	41411753651	Cornice superiore completa / Upper frame / Oberblende / Panneau antérieur supérieur / Frontal superior	203.00
31	41411754450	Coperchio anteriore / Front cover / Vorderdeckel / Couvercle antérieur / Tapa anterior	118.00
32	41201104500	Cerniera pz.2 / Hinge Pcs.2 / Scharnier St.2 / Charnière Pcs.2 / Bisagra Pz.2	32.00
33	41411753950	Coperchio serbatoio / Hopper cover / Deckel Pelletbehälter / Couvercle réservoir / Tapa depósito	111.00
34	4120180	Gommini paracolpi (4 pz) / Rubber bumpers (4 pcs.) / Schlagschutzgummi (4 Stck) / Pièces caoutchouc antichoc (4 pcs) / Cauchitos anti-golpes (4 pz)	21.00

MCZ GROUP

SELECTA 25 S1

Porta fuoco / Fire door / Feuertür / Porte foyer / Puerta hogar

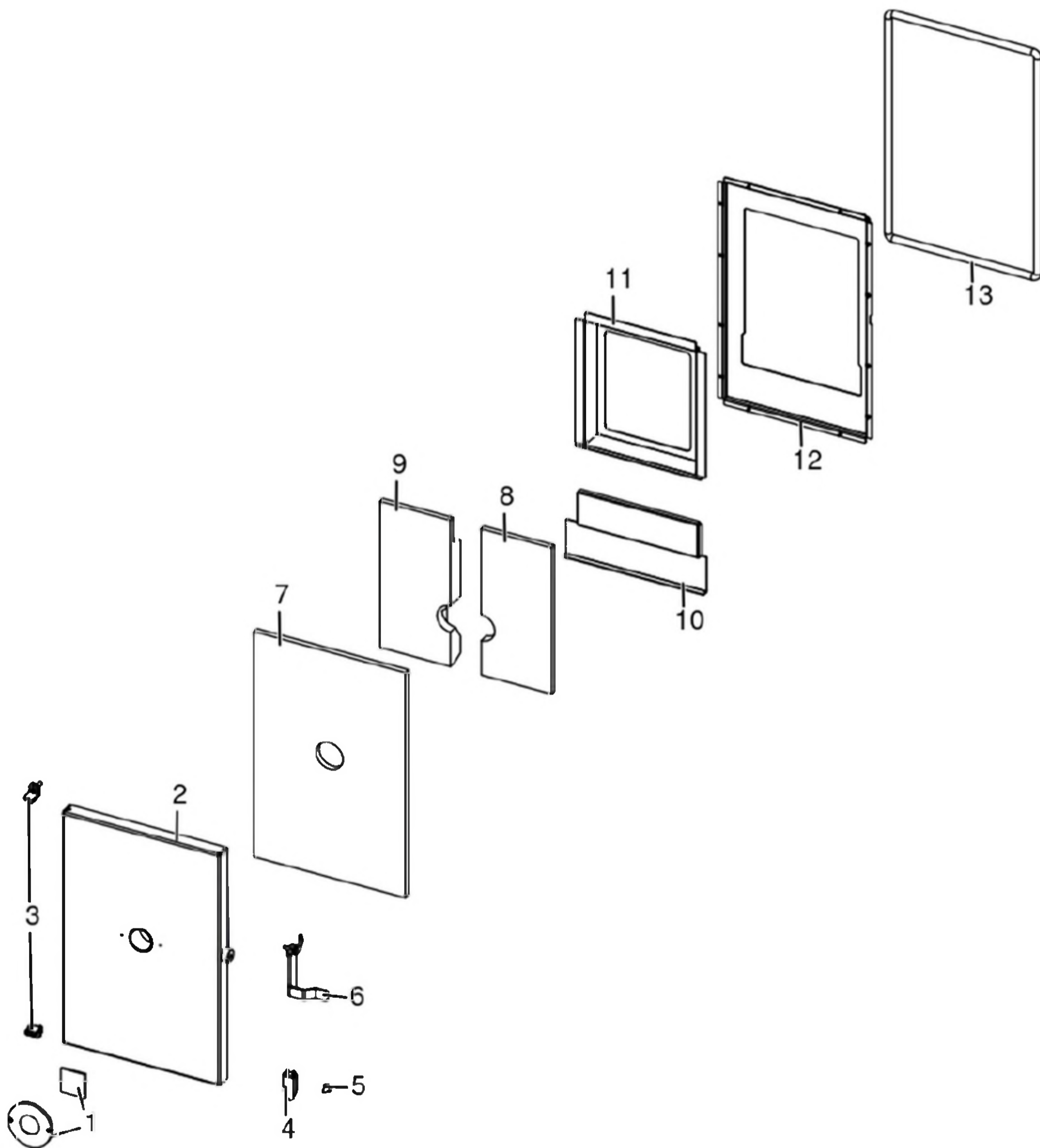

SELECTA 25 S1

Porta fuoco / Fire door / Feuertür / Porte foyer / Puerta hogar

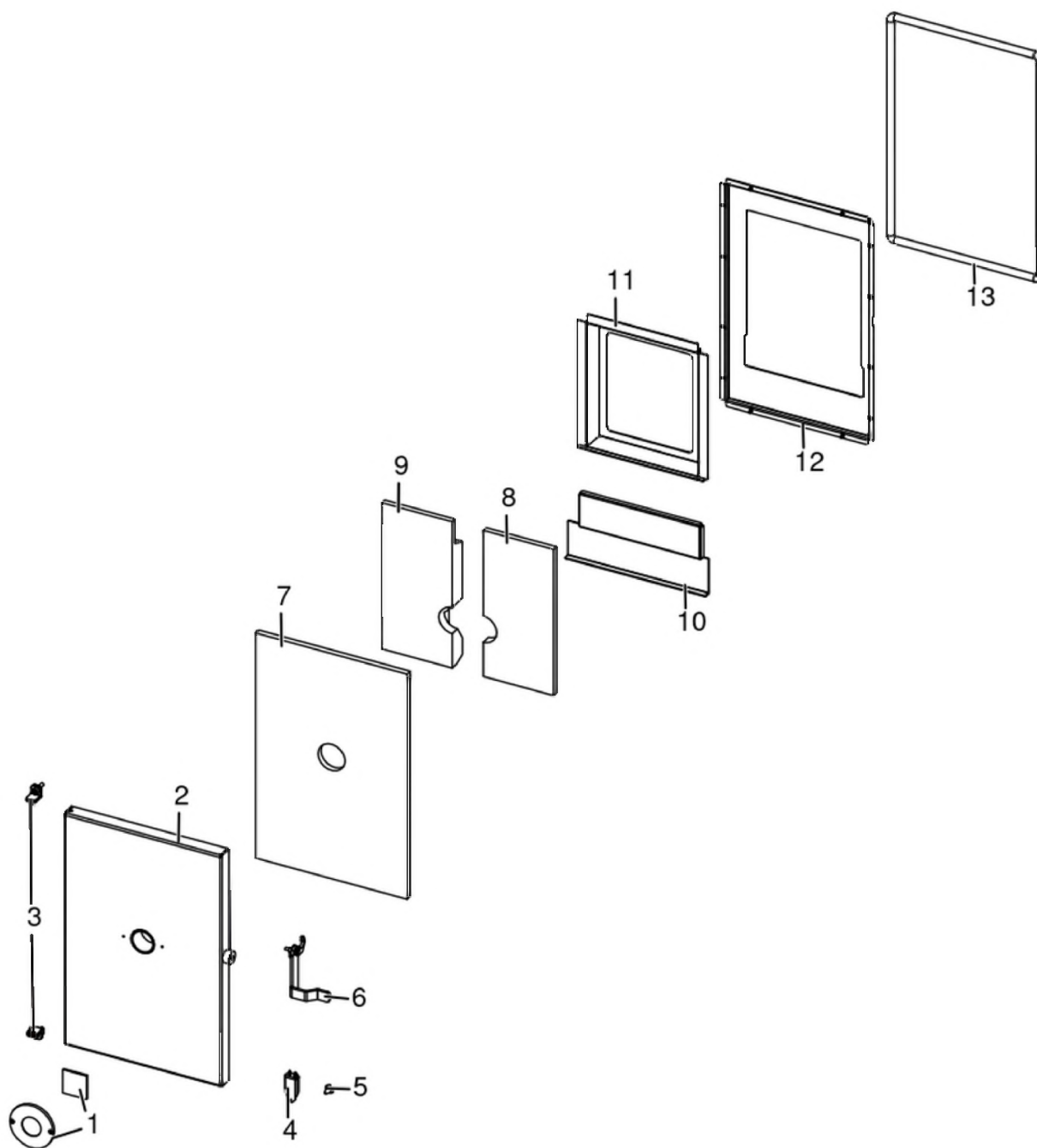

N°	Codice/Code	Descrizioni / Description / Beschreibung / Description / Descripción	Prezzo (€)
1	41201302800V	Spioncino con vetro - Spioncino Ø 40 / Peephole with glass - Peephole Ø 40 / Guckloch mit Scheibe - Guckloch Ø 40 / Judas avec vitre - Judas Ø 40 / Mirilla con cristal - Mirilla Ø 40	38.00
2	4141175324100	Porta focolare nera / Black fireplace door / Schwarze Feuerstelle Tür / Porte foyer noire / Puerta hogar negra	124.00
3	412008063	Cerniere porta fuoco (2 pz) / Fire door hinge (2pcs) / Scharnier Feuertür (2 Stck) / Charnière porte foyer (2 pcs) / bisagra puerta del hogar (2 pz)	27.00
4	41401831030	Staffa sicurezza porta cenere / Ash holder safety bracket / Aschentür Sicherheitsbügel / Support de sécurité pour porte-cendres / Soporte de seguridad porta cenizas	11.00
5	41801002300	Paracolpi in silicone Ø 8/5 (2pz) / Silicone bumpers Ø 8/5 (2pcs) / Schlagschutzgummi Ø 8/5 (2 Stck) / Pièces silicone antichoc Ø 8/5 (2pcs) / Anti-golpes en silicona Ø 8/5 (2pzs)	18.00
6	4141187733000	Maniglia porta focolare / Fire door handle / Feuertür Griff / Poignée porte foyer / Tirador puerta fuego	26.00
7	41151702900	Isolante porta focolare / Firebox door insulating material / Feuerraumtürisolierung / Isolation de la porte du foyer /	51.00

		Aislamiento de la puerta de la cámara de combustión	
8	41151703000	Vermiculite sinistra porta focolare / Left vermiculite door hearth / Linker Vermiculit-Türherd / Foyer de porte gauche en vermiculite / Hogar puerta de vermiculita izquierda	57.00
9	41151703100	Vermiculite destra porta focolare / Right vermiculite door hearth / Rechter Vermiculit-Türherd / Foyer de porte droit en vermiculite / Hogar de puerta de vermiculita derecha	55.00
10	41401717430	Sostegno scudo porta focolare / Fireplace door cover support / Feuerraumtür Abdeckung Halterung / Support couverture porte foyer / Soporte protector puerta hogar	40.00
11	41401717530	Scudo porta focolare / Fireplace door cover / Feuerstelle Tür Abdeckung / Coverture porte foyer / Tapa puerta hogar	49.00
12	41401717631	Tamponazione porta focolare / Fireplace door infilling / Füllung Feuerraumtür / Remplissage de porte de foyer / Relleno de la puerta hogar	52.00
13	412007003A	Cordino fibroceramico Ø 14 mm (5 mt.) / Ceramic fibre cord Ø 14 mm (5 m.) / Keramikfaserschnur Ø 14 mm (5 m) / Cordon en fibre céramique Ø 14 mm (5 m) / Junta a cuerda de fibra cerámica Ø 14 mm (5 m)	44.00
13	412007003B	Cordino fibroceramico Ø 14 mm (50 mt.) / Ceramic fibre cord Ø 14 mm (50 m.) / Keramikfaserschnur Ø 14 mm (50 m) / Cordon en fibre céramique Ø 14 mm (50 m) / Junta a cuerda de fibra cerámica Ø 14 mm (50 m)	300.00

MCZ GROUP

SELECTA 25 S1

Gruppo caricamento pellet acciaio / Pellet feed group in steel / Pellet Fördergruppe aus Stahl / Groupe de chargement pellet en acier / Grupo de carga pellet acero

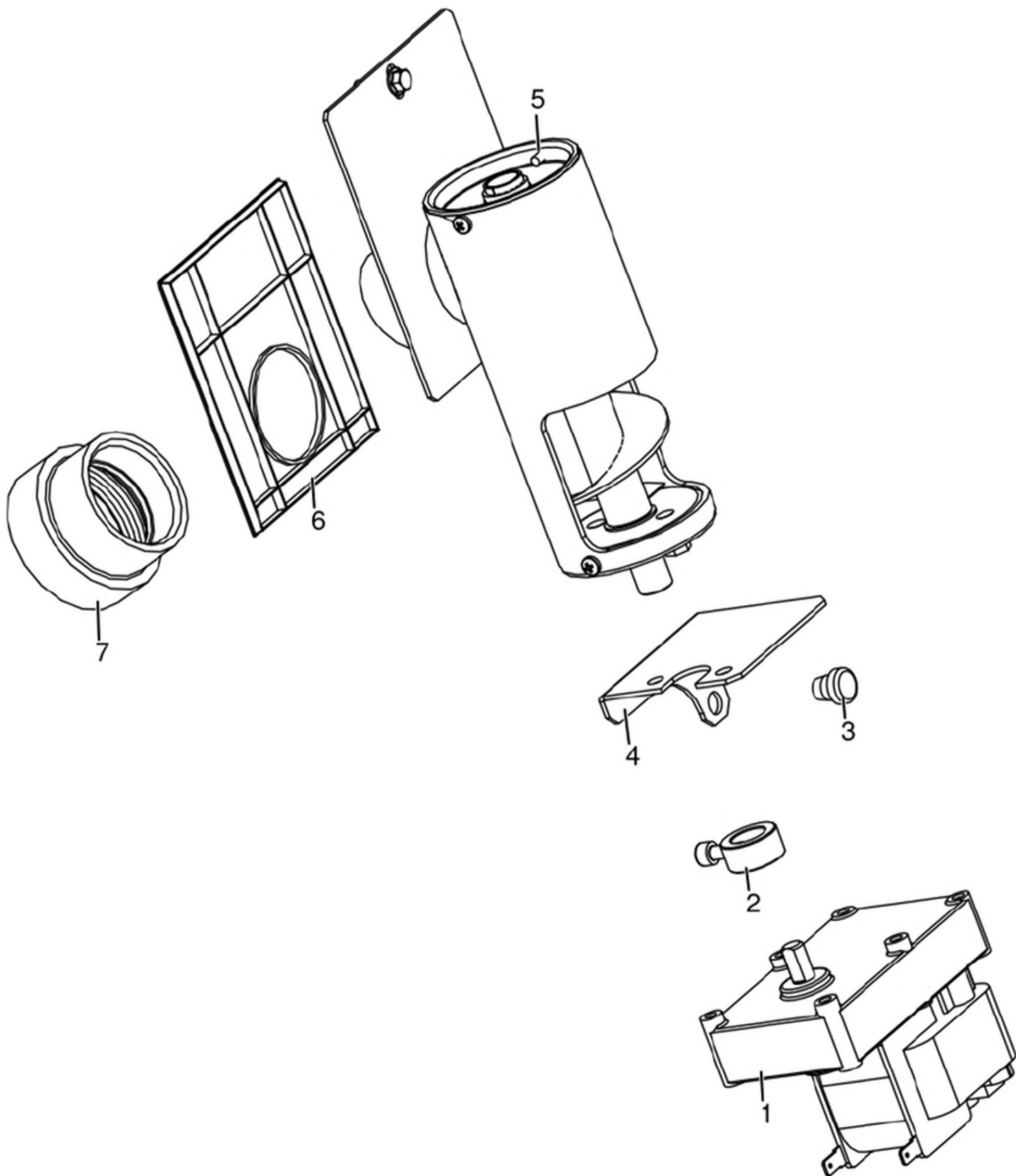

SELECTA 25 S1

Gruppo caricamento pellet acciaio / Pellet feed group in steel / Pellet Fördergruppe aus Stahl / Groupe de chargement pellet en acier / Grupo de carga pellet acero

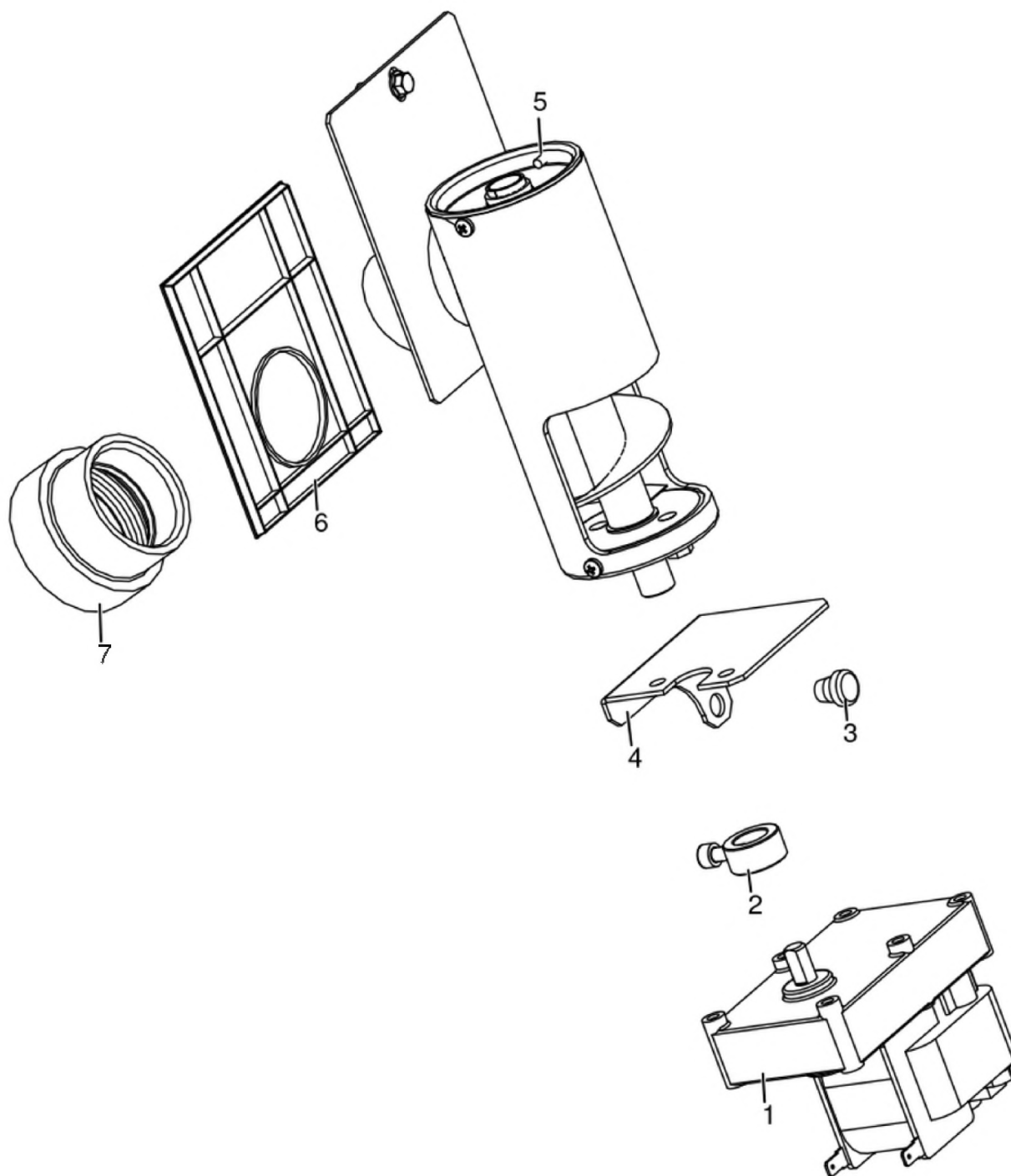

N°	Codice/Code	Descrizioni / Description / Beschreibung / Description / Descripcion	Prezzo (€)
1	41450901600	Motoriduttore 3,3 rpm Merkle Korff / Reduction motor 3,3 rpm Merkle Korff / Getriebemotor 3,3 RPM MERKLE KORFF / Motoréducteur 3,3 RPM MERKLE KORFF / Motorreductor 3,3 rpm Merkle Korff	95.00
2	4120398	Connettore motoriduttore-coclea / Reduction motor-feed screw connector / Verbindung Getriebemotor-Schnecke / Connecteur motoréducteur-vis sans fin / Conector motorreductor-cóclea	22.00
3	4120180	Gommini paracolpi (4 pz) / Rubber bumpers (4 pcs.) / Schlagschutzgummi (4 Stck) / Pièces caoutchouc antichoc (4 pcs) / Cauchitos anti-golpes (4 pz)	21.00
4	41401606430	Staffa fermo motoriduttore / Reduction motor bracket stop / Getriebemotor Bügelstopper / Butée étrier motoréducteur / Tope zuncho motorreductor	21.00

5	41411800151	Gruppo alimentazione completo / Complete feed screw / Komplette Förderschnecke / Vis sans fin complète / Coclea de carga completa	113.00
6	41801600400	Guarnizione gruppo caricamento / Gasket / Dichtung / Joint / Junta	20.00
7	41801702600	Disaccoppiatore mesc. Marrone / Brown disengaging device / Braun Verängungsrohr / Tuyau de découplage maron / Tubo de desvío marron	18.00

MCZ GROUP

SELECTA 25 S1

Gruppo caricamento pellet alluminio / Pellet feed group aluminium / Pellet Fördergruppe Aluminium /
Groupe de chargement pellet aluminium / Grupo de carga pellet aluminio

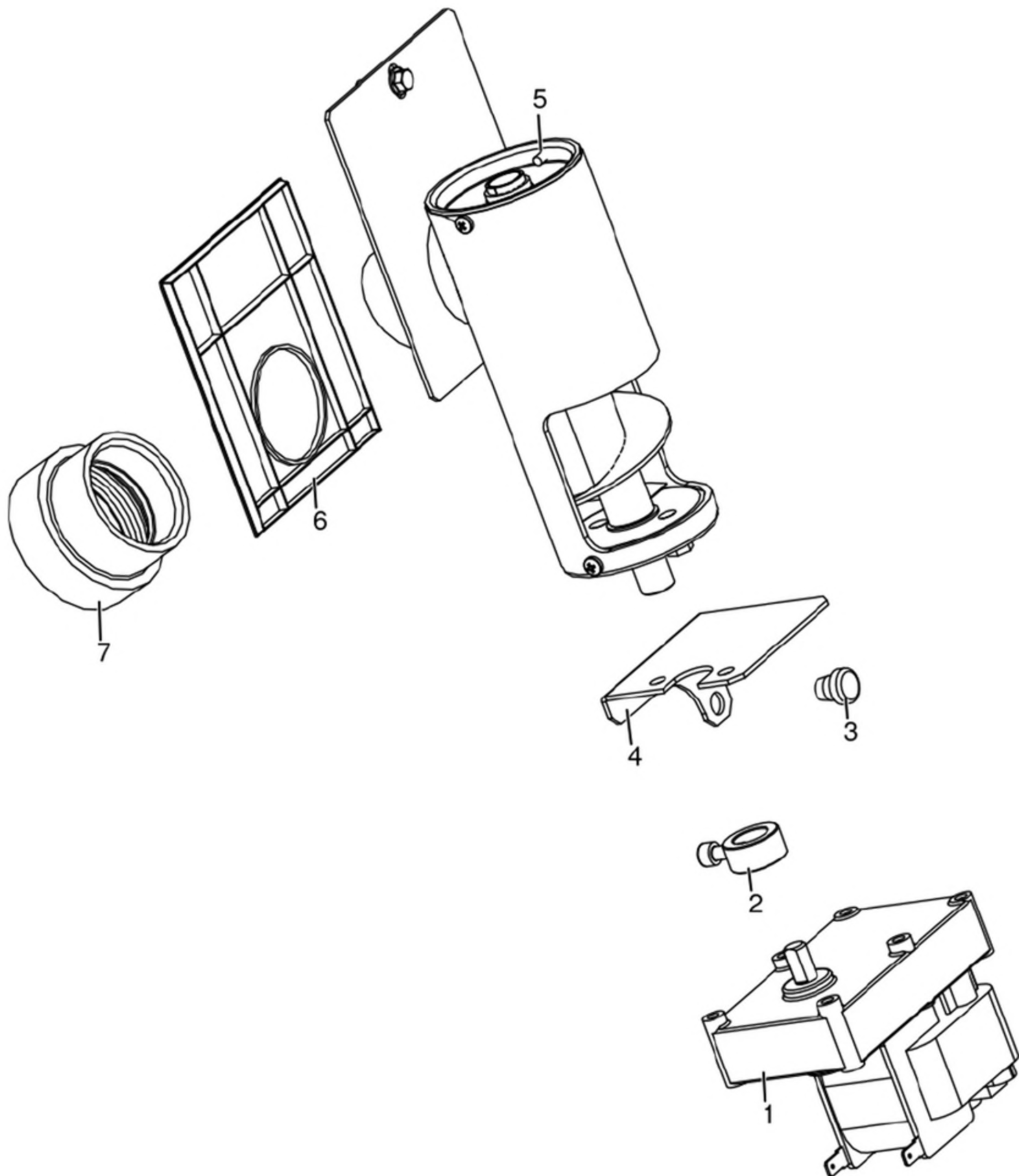

SELECTA 25 S1

Gruppo caricamento pellet alluminio / Pellet feed group aluminium / Pellet Fördergruppe Aluminium / Groupe de chargement pellet aluminium / Grupo de carga pellet aluminio

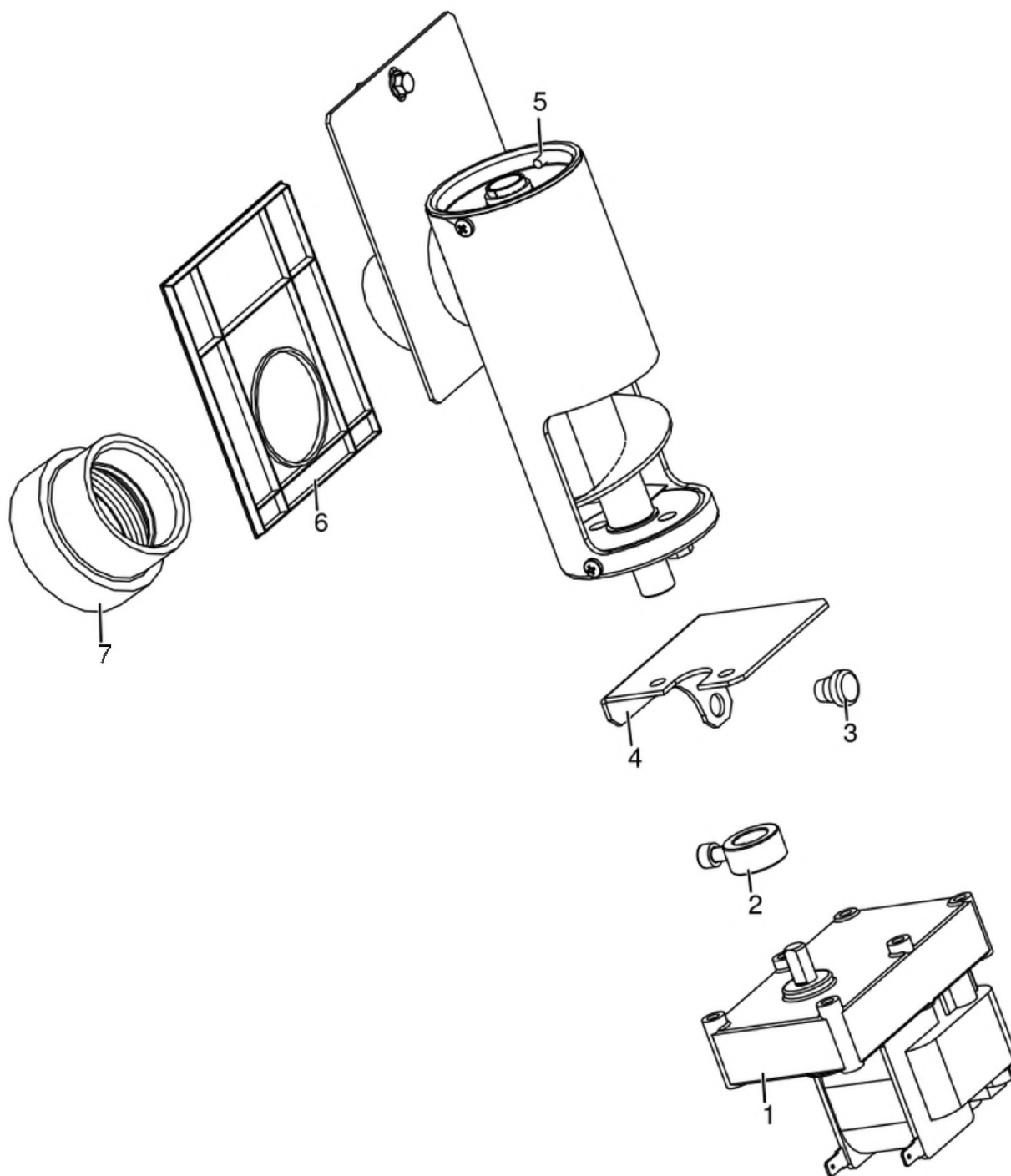

N°	Codice/Code	Descrizioni / Description / Beschreibung / Description / Descripcion	Prezzo (€)
1	41450901600	Motoriduttore 3,3 rpm Merkle Korff / Reduction motor 3,3 rpm Merkle Korff / Getriebemotor 3,3 RPM MERKLE KORFF / Motoréducteur 3,3 RPM MERKLE KORFF / Motorreductor 3,3 rpm Merkle Korff	95.00
2	4120398	Connettore motoriduttore-coclea / Reduction motor-feed screw connector / Verbindung Getriebemotor-Schnecke / Connecteur motoréducteur-vis sans fin / Conector motorreductor-cóclea	22.00
3	4120180	Gommini paracolpi (4 pz) / Rubber bumpers (4 pcs.) / Schlagschutzgummi (4 Stck) / Pièces caoutchouc antichoc (4 pcs) / Cauchitos anti-golpes (4 pz)	21.00
4	41401606430	Staffa fermo motoriduttore / Reduction motor bracket stop / Getriebemotor Bügelstopper / Butée étrier motoréducteur / Tope zuncho motorreductor	21.00

5	41402002050	Gruppo alimentazione / Complete feed screw / Komplette Förderschnecke / Vis sans fin complète / Coclea de carga completa	98.00
6	41802000300	Guarnizione / Gasket / Dichtung / Joint / Junta	11.00
7	41801702600	Disaccoppiatore mesc. Marrone / Brown disengaging device / Braun Verängungsrohr / Tuyau de découplage maron / Tubo de desvío marron	18.00

MCZ GROUP

SELECTA 25 S1

Gruppo accensione / Ignition group / Entzündung Gruppe / Groupe d'allumage / Grupo ignición

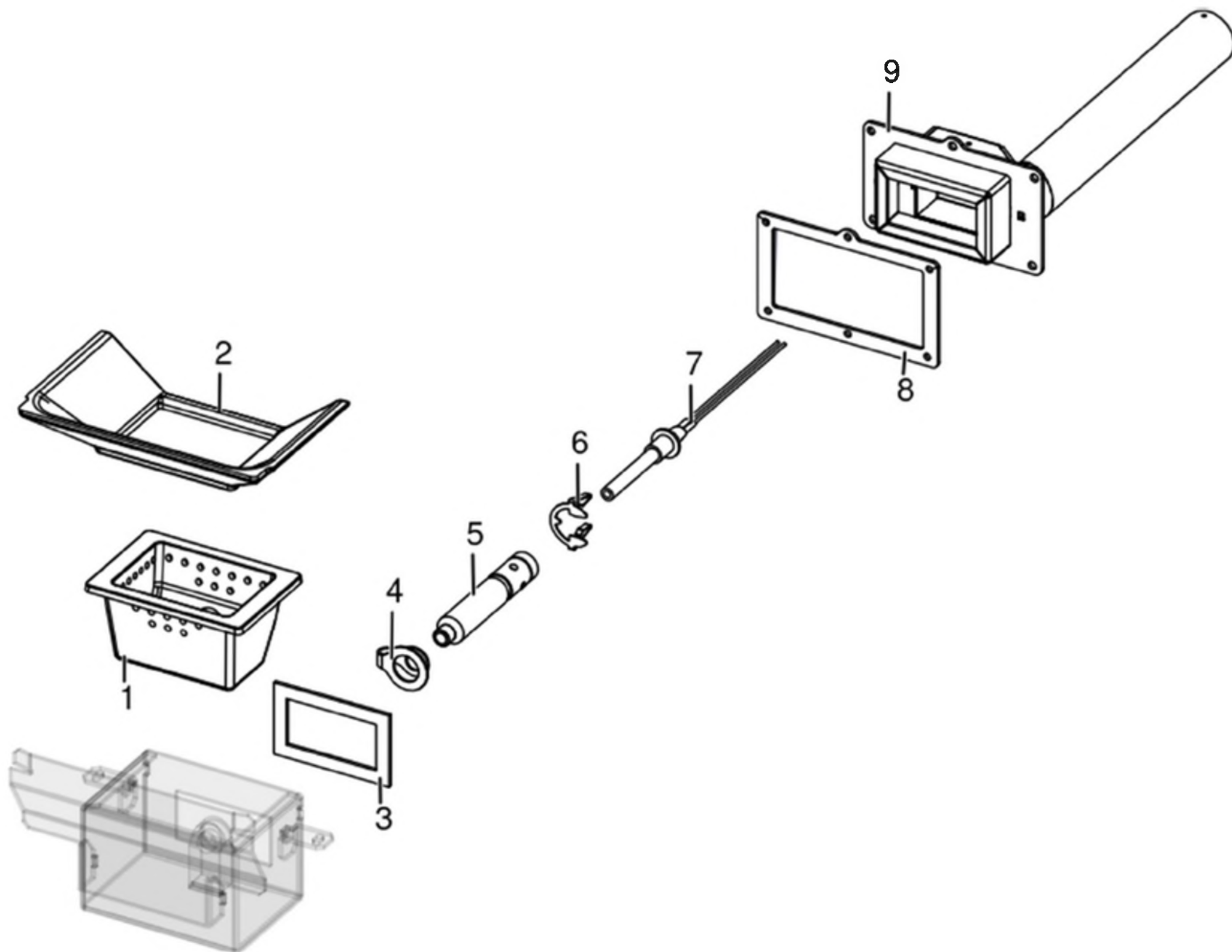

SELECTA 25 S1

Gruppo accensione / Ignition group / Entzündung Gruppe / Groupe d'allumage / Grupo ignición

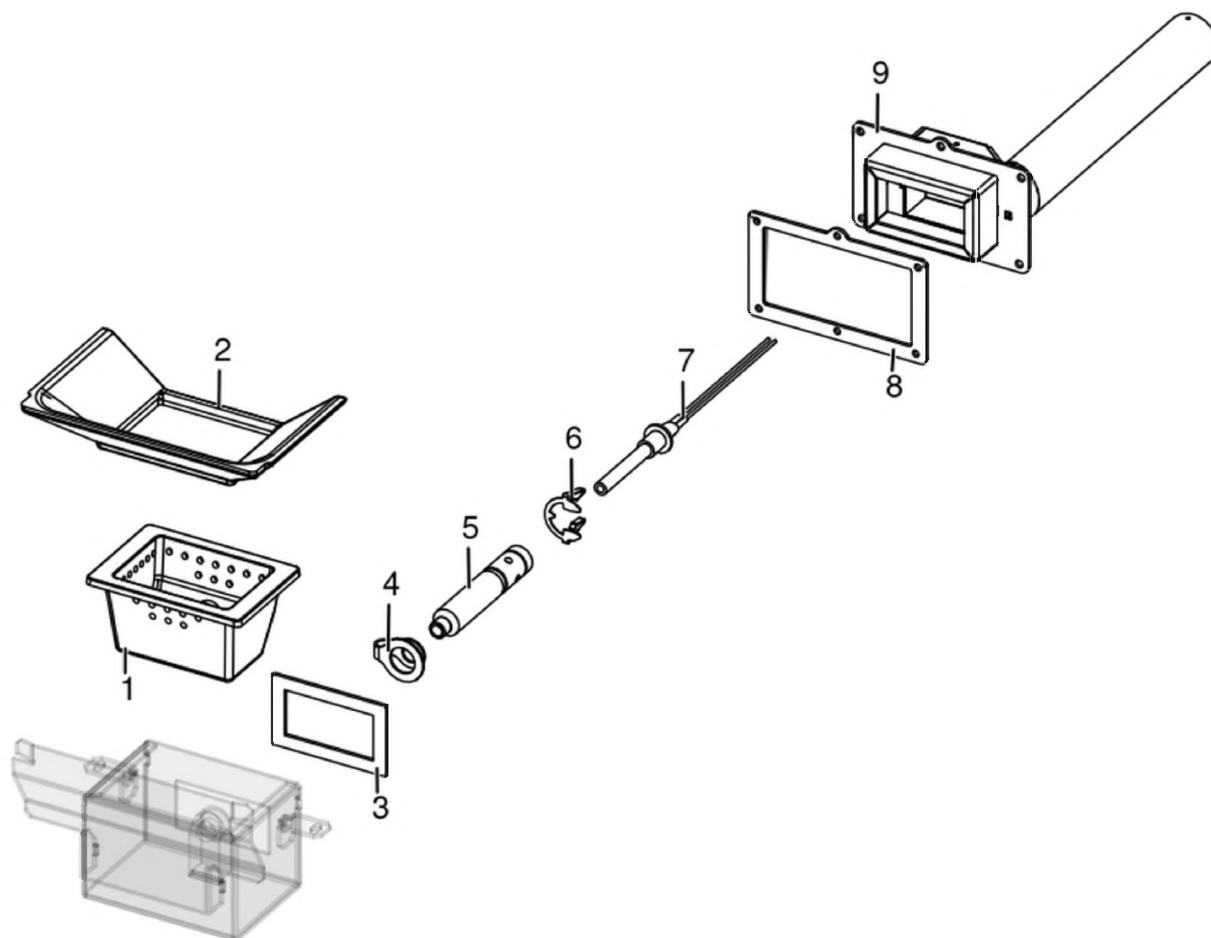

N°	Codice/Code	Descrizioni / Description / Beschreibung / Description / Descripción	Prezzo (€)
1	41301602601V	Braciere ghisa / Cast iron brazier / Bernnschale aus Guß / Brasero en fonte / Brasero de arrabio	58.00
2	41301601200V	Scivolo braciere ghisa autopulente / Self-cleaning grate amp / Selbstreinigend Brennerkopf Rutsche / Glissèrie brasero autonettoyant / Tobogán brasero autolimpiador	64.00
3	41801605800	Guarnizione tasca braciere / Combustion pot container gasket / Brenntopfkasten Dichtung / Joint récipient brasero / Burlate contenidor brasero	25.00
4	41801604300	Guarnizione condotto candelella / Sparkplug conduit gasket / Dichtung Zündkerzenkanal / Joint conduit bougie / Junta conducto bujía	19.00
5	41601802700	Condotto candelella / Sparkplug Conduit / Zündkerzenkanal / Conduit Bougie / Conducto Bujía	36.00
6	41201601500	Anello arresto candelella / Sparkplug stop / Zündkerzestopper / Butée bougie / Tope bujía	24.00
7	41451308101	Candelella 315 Watt / Sparkplug 315 Watt / Zündkerze 315 Watt / Bougie 315 Watt / Bujía 315 Watt	77.00
8	418008027	Guarnizione / Gasket / Dichtung / Joint / Junta	22.00
9	41421608341V	Scatola aria comburente / Combustion air box / Verbrennungsluft Kasten / Boîte air de combustion / Caja aire de combustión	79.00

SELECTA 25 S1

Gruppo elettrico ed elettronico / Electrical and electronic group / Elektrische und elektronische Gruppe /
Groupe électrique et électronique / Grupo eléctrico y electrónico

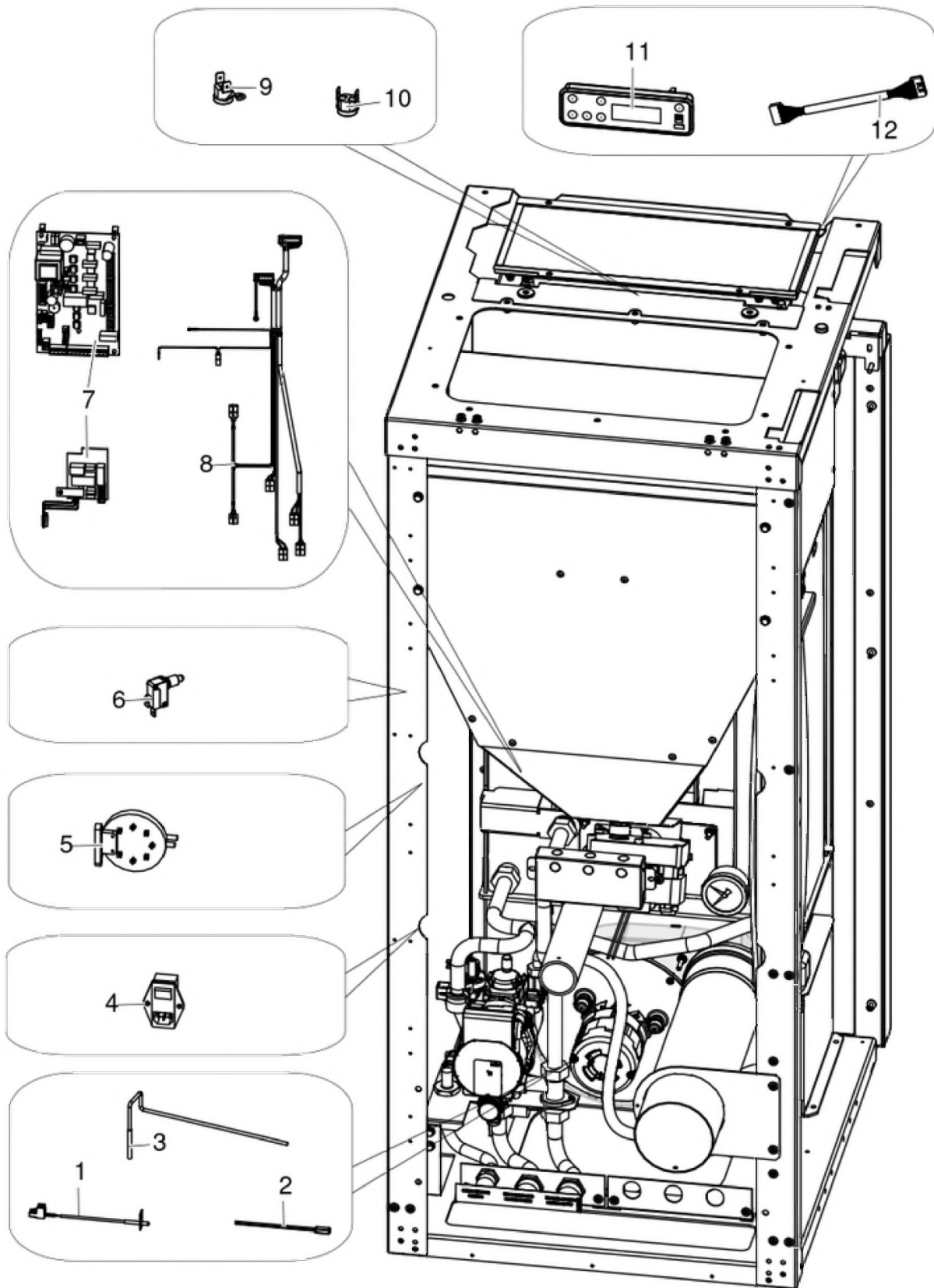

N°	Codice/Code	Descrizioni / Description / Beschreibung / Description / Descripcion	Prezzo (€)
1	41452008700	Sonda fumi con flangia L.880 mm / Smoke sensor with flange L.880 mm / Rauchsonde mit Flansche L.880mm / Sonde fumées avec bride L.880mm / Sonda humos con brida L.880mm	26.00
2	4160386	Sonda temperatura ambiente/acqua / Room/Water temperature sensor / Raum- Wassertemperaturfühler / Sonde température ambiance/eau / Sonda temperatura ambiente/agua	21.00
3	4012062	Sonda NTC a filo per acqua / Water temperature sensor / Wassertemperaturfühler / Sonde température eau / Sonda temperatura agua	21.00
4	4160193	Pulsante accensione / On/Off button / Zündungstaste / Touche d'allumage / Botón encendido	28.00
5	4160482	Pressostato 0,4 mbar / Pressure gauge 0,4 mbar / Druckschalter 0,4 mbar / Pressostat 0,4 mbar / Presostato 0,4 mbar	38.00
6	4160457	Pulsante per l'interruzione dell'alimentazione elettrica / power supply on-off button / Taste zur Unterbrechung der Stromversorgung / Bouton d'arrêt de l'alimentation électrique / Botón de corte de la alimentación eléctrica	20.00
7	41451200500C	Scheda madre / Motherboard / Hauptplatine / Carte mère / Tarjeta madre	173.00
7	41451200500	Scheda madre completa / Complete mother board / Komplette Hauptplatine / Carte mère complete / Tarjeta madre completa	171.00
7	41451200500B	Scheda madre non programmata / Unprogrammed motherboard / Unprogrammierte Hauptplatine / Carte mère non programmée / Tarjeta madre sin programa	169.00
8	41451702601	Cablaggio elettrico / Electrical wiring / Elektrische Verkabelung / Câblage électrique / Cableado eléctrico	88.00
8	41451702600	Cablaggio elettrico / Electrical wiring / Elektrische Verkabelung / Câblage électrique / Cableado eléctrico	79.00
9	412007004	Clickson 110°C / Clickson 110°C / Clickson 110°C / Clickson 110°C / Clickson 110°C	20.00
10	41451601900	Termostato a contatto 85°C / Thermostat 85°C / Thermostat 85°C / Thermostat 85°C / Termóstato 85°C	22.00
11	41451200600	Pannello comandi / Control panel / Bedienblende / Panneau de commande / Panel de mandos	102.00
12	41451201900	Cavo Flat L 1,4 M / Flat cable L 1,4 M / Flat Kable L 1,4 M / Câble Flat L 1,4 M / Cable Flat L 1,4 M	21.00

MCZ GROUP

SELECTA 25 S1

Gruppo fumi / Smoke group / Rauchgruppe / Groupe fumées / Grupo de humos

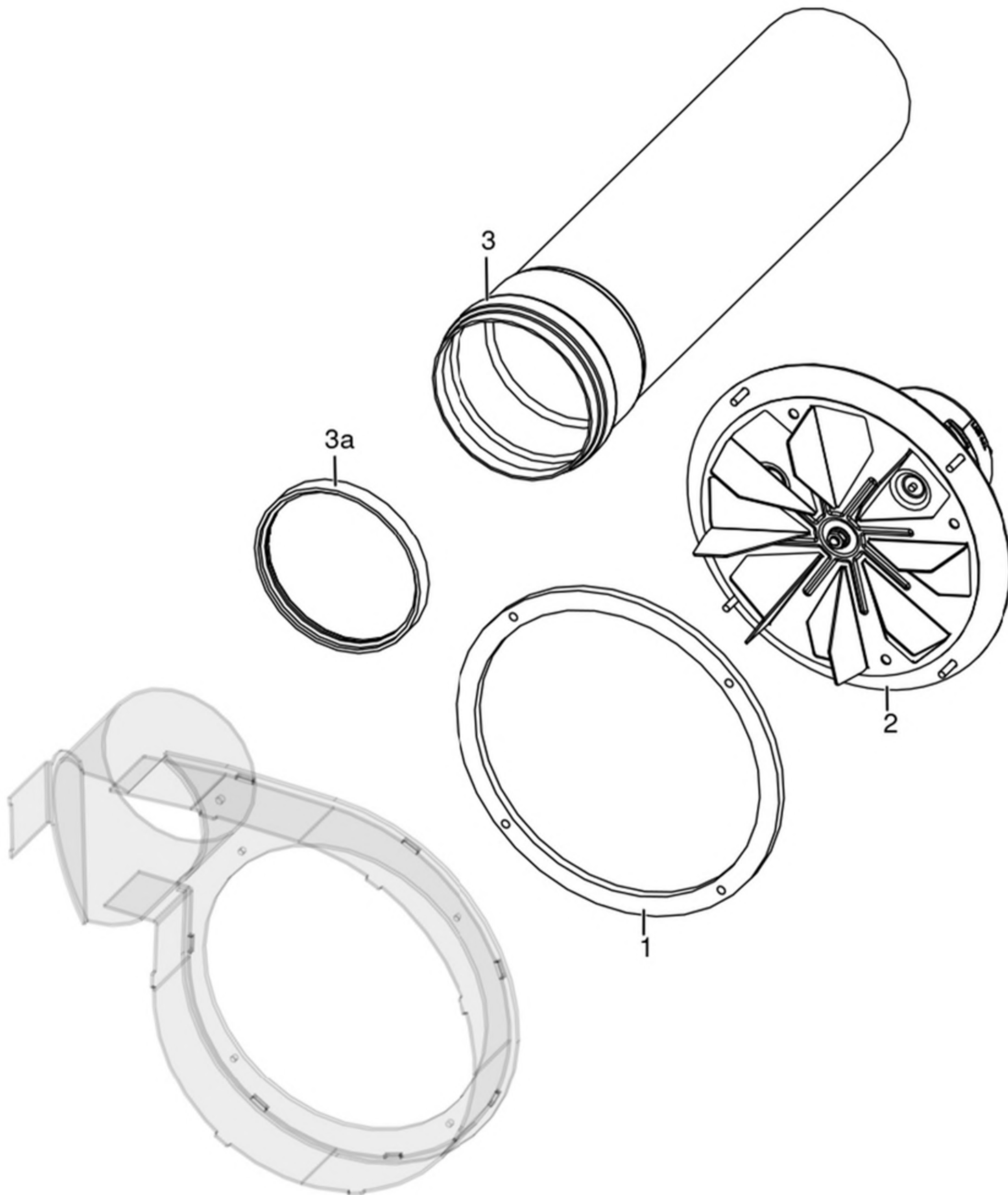

SELECTA 25 S1

Gruppo fumi / Smoke group / Rauchgruppe / Groupe fumées / Grupo de humos

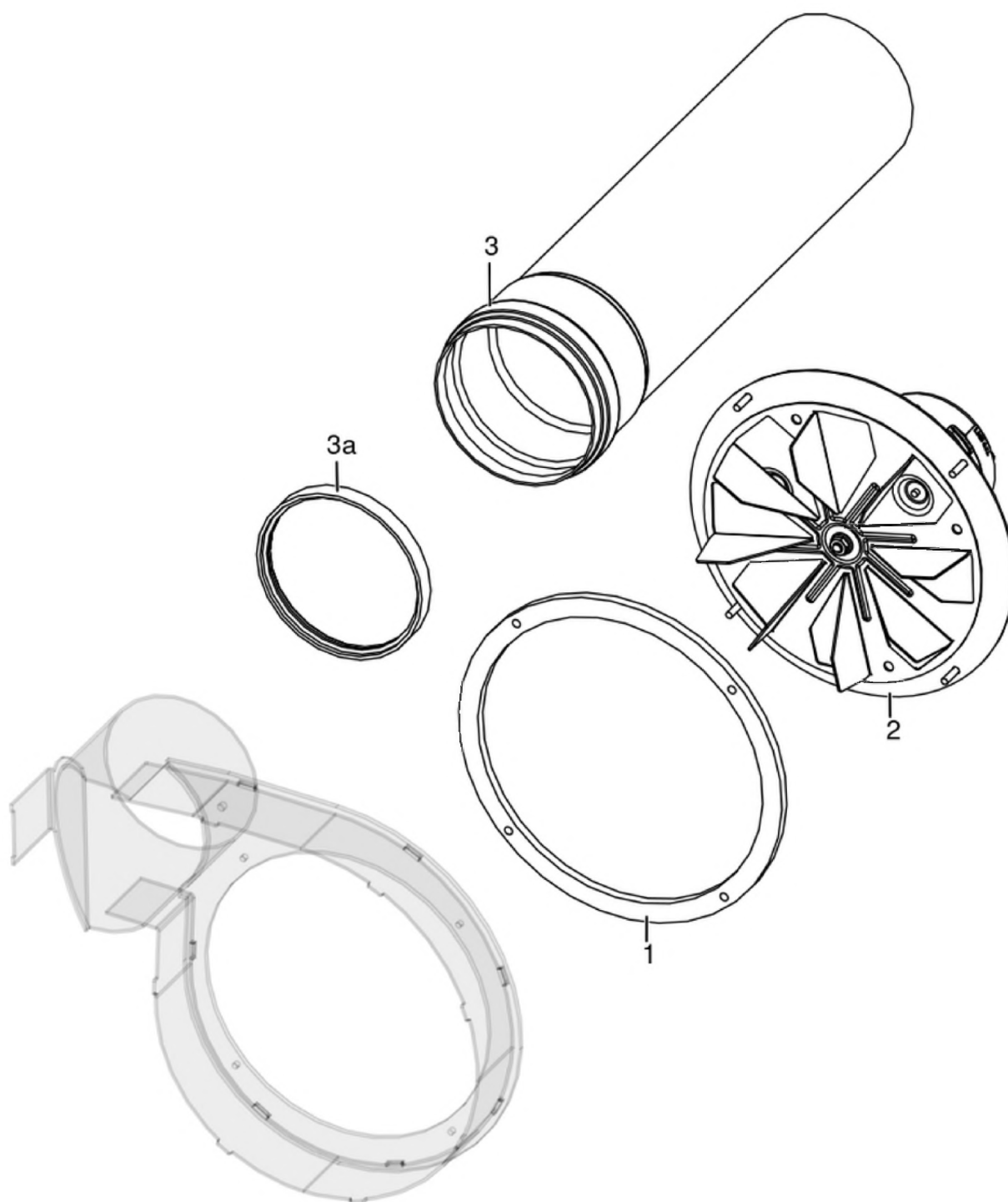

N°	Codice/Code	Descrizioni / Description / Beschreibung / Description / Descripcion	Prezzo (€)
1	41801301500	Guarnizione ventilatore fumi / Smoke exhaust fan gasket / Dichtung Rauchabsauggebläse / Joint Ventilateur aspiration fumées / Junta ventilador aspiración humos	20.00
2	41451600100	Ventilatore fumi senza chiocciola stagno / Air-tight smoke exhausted fan / Luftdicht Rauchgasgebläse / Ventilateur fumées étanche / Ventilador humos hermético	210.00
3	41601703850	Tubo fumi a innesto con Ø 100 con guarnizione / Plug-in smoke pipe with Ø 100 with gasket / Rauchrohr mit Ø 100 und Dichtung einstecken / Tuyau de fumée enfichable Ø 100 avec joint / Tubo de humos enchufable con Ø 100 con junta	33.00
3a	40A12022	Guarnizione Ø 100 - 5 Pz / Gasket Ø 100 - 5 Pcs / Dichtung Ø 100 - 5 Stck / Joint Ø 100 - 5 Pcs / Junta Ø 100 - 5	16.00

Pzs

SELECTA 25 S1

Gruppo componenti idraulici / Hydraulic components group / Hydraulische Komponenten / Groupe de composants hydrauliques / Grupo de componentes hidráulicos

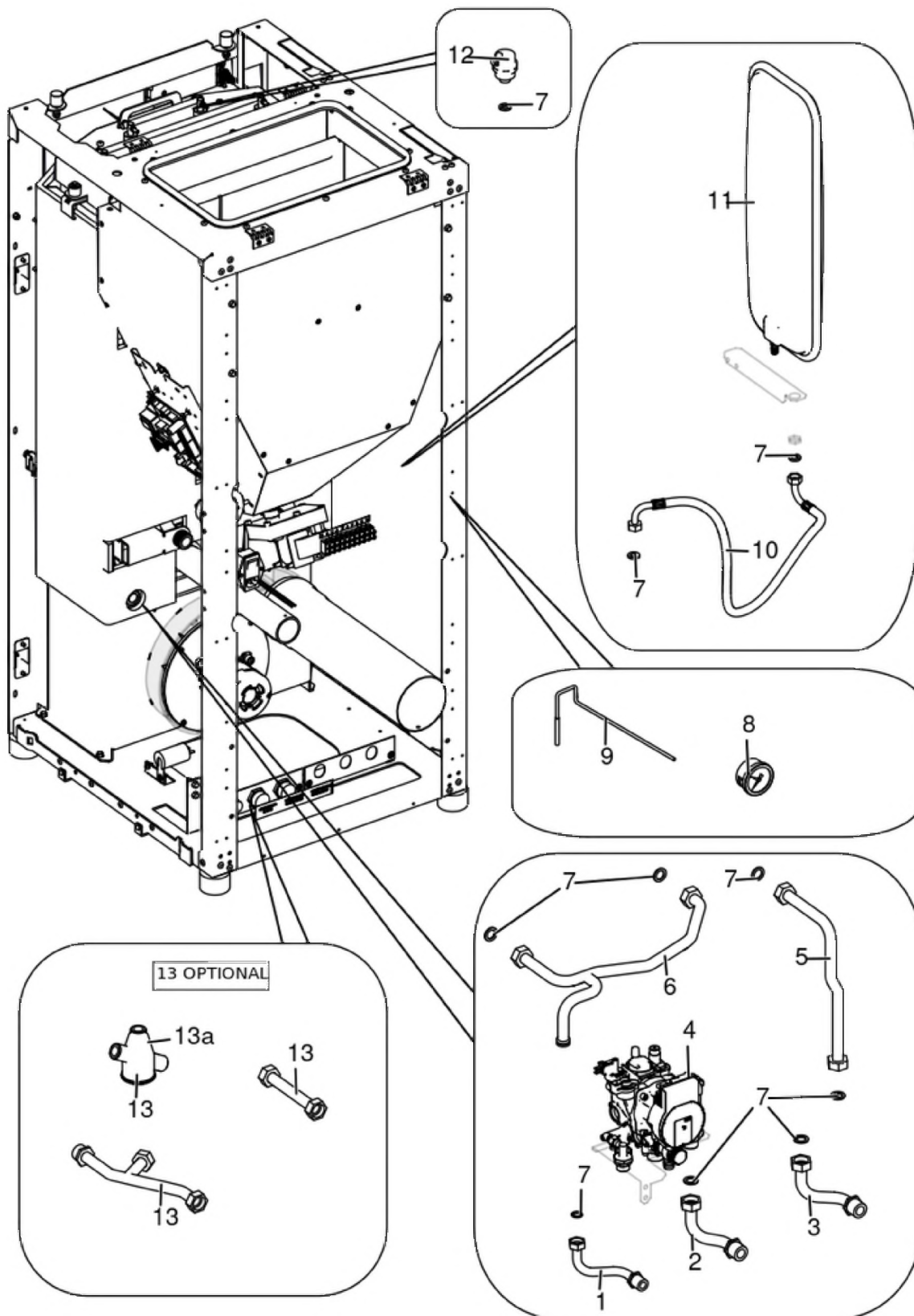

N°	Codice/Code	Descrizioni / Description / Beschreibung / Description / Descripcion	Prezzo (€)
1	41501600400	Tubo di carico caldaia / Boiler loading tube / Rohr für Kesseleinfüllung / Tuyau de chargement chaudière / Tubo de carga caldera	35.00
2	41501600700	Raccordo mandata impianto / Delivery tube connection / Vorlaufrohr Verbindung / Raccord tuyau refoulement / Raccor tubo de envío	38.00
3	41501600500	Tubo ritorno impianto / Return tube / Rücklaufrohr / Tuyau retour / Tubo de regreso	38.00
4	41501600251	Kit idraulico pompa Wilo Para alta efficienza / Hydraulic kit high efficiency pump Wilo Para / Hydraulische Baugruppe hoch Effizienz Pumpe Wilo Para / Kit hydraulique pompe de circulation Wilo Para haut rendement / Kit fontanero bomba circulación Wilo Para alto rendimiento	302.00
4	41502002100	Circolatore Wilo Para 7 IPWM / Water circulation pump Wilo Para 7 IPWM / Umwälzpumpe Wilo Para 7 IPWM / Pompe de circulation Wilo Para 7 IPWM / Bomba de circulación agua Wilo Para 7 IPWM	314.00
4	41502000200	Valvola by pass / By pass valva / Ventile By Pass / Soupape By Pass / Válvula by pass	16.00
4	41501103300	Valvola di sicurezza 3 Bar / Maximum pressure valve 3 Bar / Sicherheitsventil 3 Bar / Soupape de pression maximale 3 Bar / Válvula máxima presión 3 Bar	32.00
4	41451108000	Pressostato di minima H2O / Pressur switch H2O / Druckwächter H2O / Pressostat H2O / Presostato H2O	31.00
5	41501600600	Tubo mandata impianto / Delivery tube / Vorlaufrohr / Tuyau refoulement / Tubo de envío	44.00
6	41501600300	Tubo circolazione caldaia / Boiler circulation tube / Rohr für Kesselumwälzung / Tuyau de circulation chaudière / Tubo de circulación caldera	58.00
7	41207910	Kit guarnizioni impianto idraulico / Hydraulic system gasket kit / Dichtungsbausatz für Hydraulikanlage / Kit de joints pour l'installation hydraulique / Kit de juntas de la instalación de fontanería	26.00
8	41501100901	Manometro / Manometer / Manometer / Manomètre / Manómetro	42.00
9	4012062	Sonda NTC a filo per acqua / Water temperature sensor / Wassertemperaturfühler / Sonde température eau / Sonda temperatura agua	21.00
10	41501601000	Tubo flessibile L.600 / Flexible tube L.600 / Flexibles Rohr L.600 / Tuyau flexible L.600 / Tubo flexible L.600	29.00
11	4120775	Vaso espansione (6 l) / Expansion vessel (6 l) / Expansionsgefäß (6 l) / Vase d'expansion (6 l) / Vaso de expansión (6 l)	75.00
12	4120779	Valvola di sfiato / Vent valve / Entlüftungsventil / Soupape de dégagement / Válvula respiradero	26.00
13	40A18011	Valvola termostatica / thermostatic valve / Thermostatventil / vanne thermostatique / Válvula termostática	216.00
13a	41501806000	Valvola anticondensa 3/4" ACV/4 / 3/4 "ACV/4 anti-condensation valve / 3/4 "ACV/4 Antikondensationsventil / Vanne anti-condensation 3/4 "ACV/4 / Válvula anticondensación 3/4 "ACV/4	224.00

SELECTA 25 S1

Gruppo scambiatore / Exchanger group / Austausch Baugruppe / Groupe échangeur / Grupo intercambiador

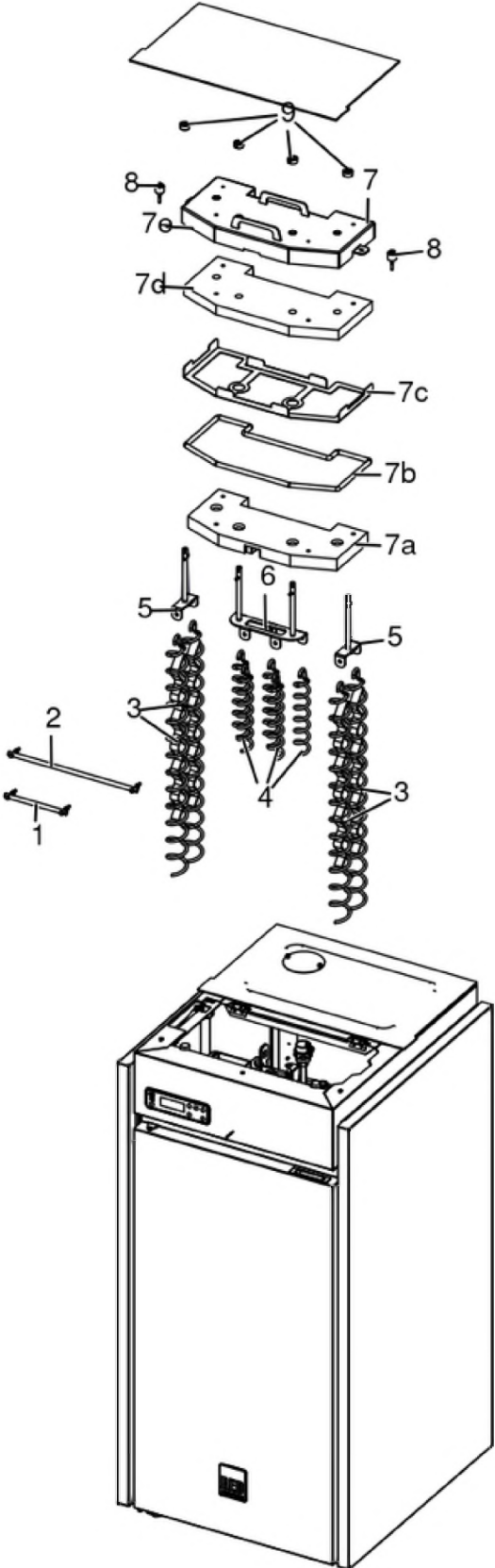

N°	Codice/Code	Descrizioni / Description / Beschreibung / Description / Descripcion	Prezzo (€)
1	41201801260	Leva movimento turbolatori interni / Internal turbulator movement lever / Innere Turbulatorbewegungshebel / Levier de mouvement interne du turbulateur / Palanca de movimiento del turbulador interno	31.00
2	41201801360	Leva movimento turbolatori esterni / External turbulator movement lever / Aussere Turbulatorbewegungshebel / Levier de mouvement du turbulateur externe / Palanca de movimiento del turbulador externo	33.00
3	41400914540	Eliche raschiatore (1 pz.) / Turbulator props (1 pc.) / Propeller des Schabers (1 Teil) / Hélices turbulateur (1 pz.) / Hélice rascador (1 pz.)	41.00
4	41331702600	Turbolatore corto inox / Short stainless steel turbulator / Kürzer Edeltahl-turbulator / Turbulateur court en acier inoxydable / Turbulador corto de acero inoxidable	36.00
5	41331702140	Asta laterale turbolatore inox / Stainless steel turbulator side rod / Seitenstange des Turbulators aus Edelstahl / Tige latérale du turbulateur en acier inoxydable / Varilla lateral del turbulador de acero inoxidable	39.00
6	41331702340	Asta centrale turbolatore inox / Central stainless steel turbulator rod / Zentrale Turbulatorstange aus Edelstahl / Tige de turbulateur centrale en acier inoxydable / Varilla del turbulador central de acero inoxidable	52.00
7	41411752150	Coperchio completo / Complete cover / Kompletter Deckel / Couvercle complet / Tapadera completa	258.00
7a	41151702700	Vermiculite coperchio / Vermiculite lid / Vermiculite Deckel / Couvercle en vermiculite / Tapa de vermiculita	63.00
7b	4120103A	Cordino fibroceramico Ø 10 mm (5 mt.) / Ceramic fibre cord Ø 10 mm (5 m) / Keramikfaserschnur Ø 10 mm (5 m) / Cordon en fibre céramique Ø 10 mm (5 m) / Junta a cuerda de fibra cerámica Ø 10 mm (5 m)	29.00
7b	4120103B	Cordino fibroceramico Ø 10 mm (50 mt.) / Ceramic fibre cord Ø 10 mm (50 m) / Keramikfaserschnur Ø 10 mm (50 m) / Cordon en fibre céramique Ø 10 mm (50 m) / Junta a cuerda de fibra cerámica Ø 10 mm (50 m)	167.00
7c	41401717130	Tamponazione coperchio / Cover filling / Füllung abdecken / Remplissage de la couverture / Relleno de la cubierta	33.00
7d	41151702600	Isolante coperchio caldaia / Boiler cover insulating material / Isolierung der Kesselabdeckung / Isolation du couvercle de la chaudière / Aislamiento de la tapa de la caldera	52.00
7e	4141175224000	Coperchio struttura nero / Black structure cover / Schwarze Struktur-Abdeckung / Couvercle de structure noir / Tapa de estructura negra	97.00
8	41801499550	Kit scarico sovrappressione camera di combustione (pz.2) / Pressure relief kit (Pcs.2) / Bausatz überdruckablauf brennkammer (Stck.2) / Kit decompression chambre combustion (Pcs.2) / Kit descompresion camara combustion (Pcs.2)	25.00
9	41200903300	Trascinatore turbolatori (2 pz.) / Turbulator props puller (2 PC.) / Reinigungsspiralenmitnehmer (2 STCK). / Meneur de turbulateur (2 Pc.) / Arrebatador hélice rascador (2 pz.)	25.00