

AIKE AIR OYSTER

Componenti Struttura Esterna / External structure components / Bauteile Aussenkorpus / Composants structure externe / Componentes estructura externa

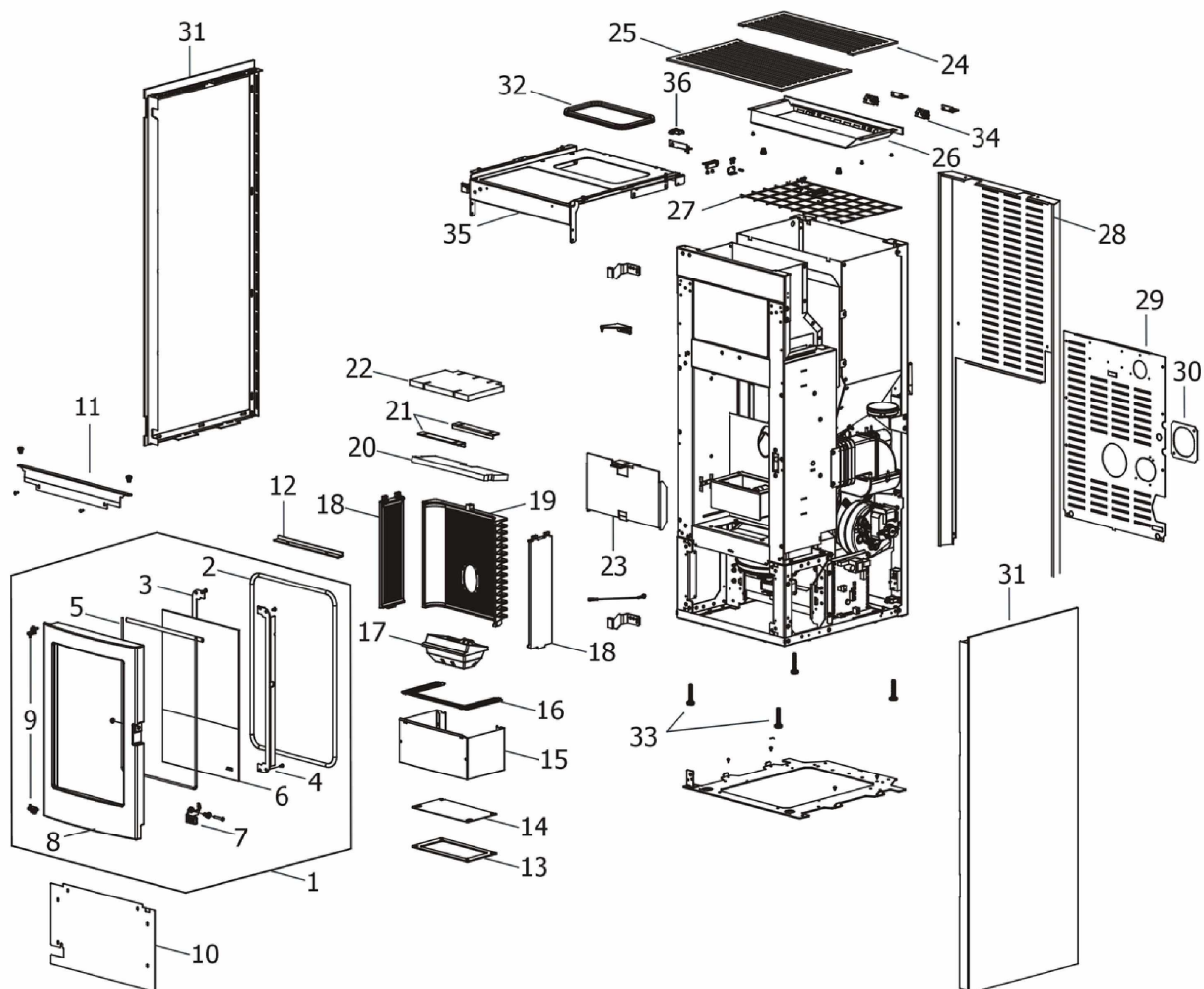

N°	Codice/Code	Descrizioni / Description / Beschreibung / Description / Descripción	Prezzo (€)
1	41301500750	Porta fuoco completa in ghisa / Cast iron complete fire door / Komplette Feuertür aus Guß / Porte foyer complète en fonte / Puerta hogar completa de arrabio	262.00
2	41201031	Kit sostituzione cordino (cordino+silicone) Ø 10 mm / Cord replacement kit (cord + silicon) Ø 10 mm / Schnuraustauschsatz (Schnur+Silikon) Ø 10 mm / Kit remplacement cordon (cordon + silicone) Ø 10 mm / Kit sustitución junta a cuerda (junta a cuerda+silicón) Ø 10 mm	43.00
2	4120103A	Cordino fibroceramico Ø 10 mm (5 mt.) / Ceramic fibre cord Ø 10 mm (5 m) / Keramikfaserschnur Ø 10 mm (5 m) / Cordon en fibre céramique Ø 10 mm (5 m) / Junta a cuerda de fibra cerámica Ø 10 mm (5 m)	29.00
2	4120103B	Cordino fibroceramico Ø 10 mm (50 mt.) / Ceramic fibre cord Ø 10 mm (50 m) / Keramikfaserschnur Ø 10 mm (50 m) / Cordon en fibre céramique Ø 10 mm (50 m) / Junta a cuerda de fibra cerámica Ø 10 mm (50 m)	167.00
3	41411413430V	Deflettore / Deflector / Leitblech / Déflecteur / Deflector	26.00
4	41411413430V	Deflettore / Deflector / Leitblech / Déflecteur / Deflector	26.00
5	41201031	Kit sostituzione cordino (cordino+silicone) Ø 10 mm / Cord replacement kit (cord + silicon) Ø 10 mm / Schnuraustauschsatz (Schnur+Silikon) Ø 10 mm / Kit remplacement cordon (cordon + silicone) Ø 10 mm / Kit sustitución junta a cuerda (junta a cuerda+silicón) Ø 10 mm	43.00
5	4120103A	Cordino fibroceramico Ø 10 mm (5 mt.) / Ceramic fibre cord Ø 10 mm (5 m) / Keramikfaserschnur Ø 10 mm (5 m) / Cordon en fibre céramique Ø 10 mm (5 m) / Junta a cuerda de fibra cerámica Ø 10 mm (5 m)	29.00
5	4120103B	Cordino fibroceramico Ø 10 mm (50 mt.) / Ceramic fibre cord Ø 10 mm (50 m) / Keramikfaserschnur Ø 10 mm (50 m) / Cordon en fibre céramique Ø 10 mm (50 m) / Junta a cuerda de fibra cerámica Ø 10 mm (50 m)	167.00
5	4120106	Guarnizione a nastro fireglass / Fireglass tape gasket / Banddichtung Fireglass / Joint ruban Fireglass / Guarnición a cinta Fireglass	28.00
6	41701400160	Vetroceramico 427x292x4 mm con guarnizione / Glass 427x292x4 mm with gasket / Glasskeramikscheibe 427x292x4 mm mit Dichtung / Vitrocéramique 427x292x4 mm avec joint / Cristal cerámico 427x292x4 mm con junta	138.00

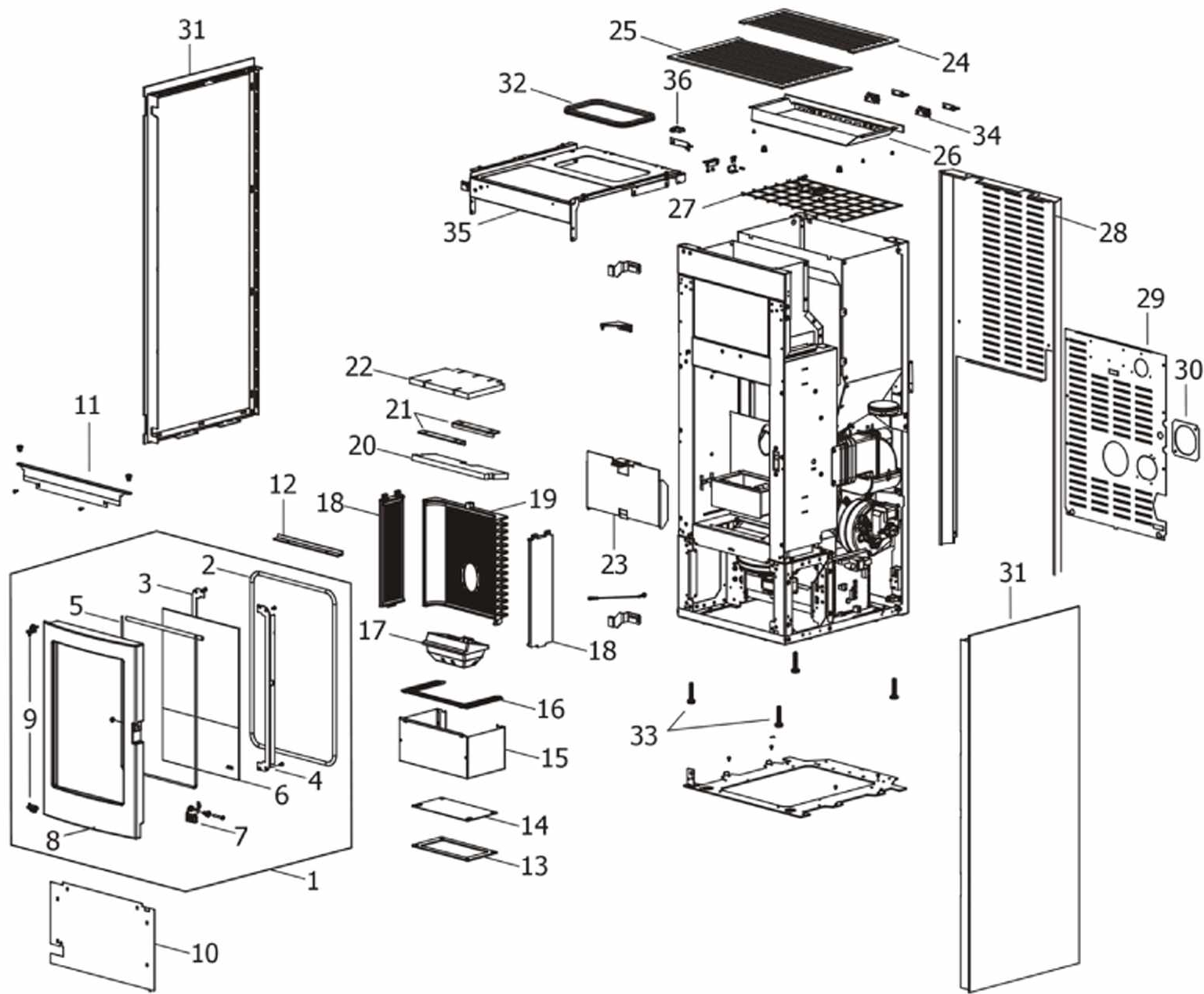

7	41411501860	Maniglia completa / Complete handle / Kompletter Griff / Poignée complète / Tirador completo	23.00
8	41301302200V	Telaio porta fuoco in ghisa / Cast iron fire door frame / Feuertürrahment aus Guß / Cadre porte foyer en fonte / Armazón puerta hogar de arrabio	146.00
9	412008063	Cerniere porta fuoco (2 pz) / Fire door hinge (2pcs) / Scharnier Feuertür (2 Stck) / Charnière porte foyer (2 pcs) / bisagra puerta del hogar (2 pz)	27.00
10	41411508010V	Componente sottoporta / Part under the door / Stück unter der Tür / Composant sous porte / Componente abajo puerta	34.00
11	41411522630V	Staffa superiore fissaggio griglia aria / Upper fastening bracket for air grille / Obere Befestigungsbügel für Lüftgitter / Etrier supérieure de fixation grille aire / Estribo superior de fijación rejilla aire	23.00
12	41401382130	Deflettore / Deflector / Leitblech / Déflecteur / Deflector	24.00
13	41800900600	Guarnizione / Gasket / Dichtung / Joint / Junta	21.00
13	41801599750	Kit 50 guarnizioni / Kit 50 gaskets / Bausatz 50 Dichtungen / Kit 50 joints / Kit 50 juntas	840.00
14	41401339610	Tappo ispezione vano fumi / Smoke compartment inspection plug / Inspektionsdeckel Rauchabzug / Clapet inspection compartiment fumées / Tapón inspección compartimento humos	21.00
15	41401421930	Cassetto cenere / Ash drawer / Aschenkasten / Tiroir à cendres / Cajón ceniza	56.00
16	41401422010V	Griglia cassetto cenere / Ash drawer grille / Aschenkastengitter / Grille tiroir à cendres / Rejilla cajón ceniza	29.00
17	41301402101V	Braciere / Brazier / Brennschale / Brasero / Brasero	59.00
18	41301302400V	Laterale in ghisa / Cast iron side / Seite aus Guß / Côté en fonte / Placa lateral de arrabio	33.00
18	41301302400V	Laterale in ghisa / Cast iron side / Seite aus Guß / Côté en fonte / Placa lateral de arrabio	33.00
19	41301302300V	Schiena in ghisa / Cast iron back / Rückwand aus Guß / Fond en fonte / Parte trasera de arrabio	54.00
20	41151403200	Deflettore in vermiculite / Vermiculite deflector / Leitblech aus Vermiculite / Déflecteur en vermiculite / Deflector en vermiculite	29.00
20	41331504730	Rinforzo per vermiculite / Vermiculite support / Vermiculite Stutze / Renfort pour vermiculite / Refuerzo para vermiculite	28.00
21	41401421630	Staffa supporto protezione in vermiculite (2 pz) / Vermiculite protection bracket (2 pcs) / Haltebügel für Schutzpaneel aus Vermiculite (2 Stck) / Patte support protection en vermiculite (2 pcs) / Estribo soporte protección en vermiculite (2 pzs)	25.00
22	41151403100	Protezione in vermiculite / Vermiculite protection / Schutzpaneel aus Vermiculite / Protection en vermiculite / Protección en vermiculite	29.00
23	41411500140	Schiena asportabile / Amovable wall / Abnehmbares Wand / Fond démontable / Pared extirpable	59.00
24	41421500650	Coperchio serbatoio pellet / Pellet hopper cover / Deckel Pelletbehälter / Couvercle réservoir pellet / Tapadera depósito	336.00
25	41421500750	Griglia aria / Air outlet grille / Warmluftgitter / Grille air chaud / Rejilla salida aire	162.00
26	41411522040P	Tamponazione superiore / Upper filler / Obere Stopfung / Plaque supérieure / Tapa superior	58.00
27	41401468060	Griglia antintrusione / Hopper protection grille / Schutzgitter Pelletbehälter / Grille de protection réservoir / Rejilla de protección depósito	30.00
28	41411522731P	Schiena posteriore / Rear back / Hintere Rückwand / Dossieret postérieur / Parte trasera	70.00
29	41401424961	Schiena posteriore inferiore / Lower rear back / Untere hintere Rückwand / Dossieret postérieur inférieur / Parte trasera inferior	39.00
30	41400904810	Flangia tubo ingresso aria / Flange for combustion air aspiration tube / Flansch Verbrennungsluft Förderrohr / Bride tuyau aspiration air comburant / Brida tubo aspiración aire de combustión	20.00
31	41411523340P	Fianco DX nero / R. Black side / R. Seite Schwarz / Côté D. noir / Lado DCHO negro	235.00
31	41411523940P	Fianco SX nero / L. Black side / L. Seite Schwarz / Côté G. noir / Lado IZDO negro	235.00
31	41411523340P	Fianco DX nero / R. Black side / R. Seite Schwarz / Côté D. noir / Lado DCHO negro	235.00
31	41411523940P	Fianco SX nero / L. Black side / L. Seite Schwarz / Côté G. noir / Lado IZDO negro	235.00
32	41801208002	Guarnizione - 2,5 m / Gasket - 2,5 m / Dichtung - 2,5 m / Joint - 2,5 m / Junta - 2,5 m	83.00
32	41801208000	Guarnizione - 5 m / Gasket - 5 m / Dichtung - 5 m / Joint - 5 m / Junta - 5 m	141.00
32	41801208001	Guarnizione - 50 m / Gasket - 50 m / Dichtung - 50 m / Joint - 50 m / Junta - 50 m	1,277.00
33	41200906660	Piedini di appoggio (4 pz.) / Support feet (4 pcs.) / Einstellfüße (4 Stck.) / Vérins d'appui (4 p.es) / Pies de apoyo (4 piezas)	19.00
34	41201307260	Cerniera (1 pz) / Hinge (1 pc) / Scharnier (1 Stk) / Charnière (1 pc) / Bisagra (1 pz)	36.00
34	41411522430V	Cerniera coperchio serbatoio / Pellet hopper hinge / Scharnier Pelletbehälter / Charnière couvercle réservoir / Bisagra tapadera depósito	18.00
35	41411521140V	Top / Top / Top / Dessus / Top	77.00
36	41411522230V	Cerniera griglia aria / Air grille hinge / Lüftgittersscharnier / Charnière grille aire / Bisagra rejilla aire	17.00
36	41411522530V	Supporto cerniera griglia aria / Stand for Air grille hinge / Fassung für Lüftgittersscharnier / Support charnière grille aire / Soporte bisagra rejilla aire	16.00

AIKE AIR OYSTER

Porta fuoco / Fire door / Feuertür / Porte foyer / Puerta hogar

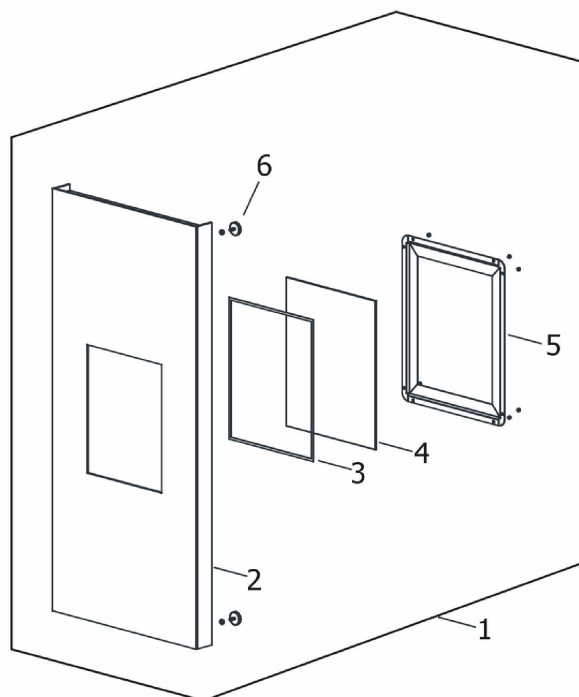

N°	Codice/Code	Descrizioni / Description / Beschreibung / Description / Descripción	Prezzo (€)
1	41421500850	Porta esterna completa / Complete external door / Komplette Außentür / Porte extérieure complète / Puerta exterior completa	466.00
2	41411521640V	Cerniera porta esterna / Hinge for external door / Scharnier für Außentür / Charnière porte extérieure / Bisagra puerta exterior	42.00
2	41411522841P	Telaio porta esterna / External door frame / Außentürrahmen / Cadre porte extérieure / Armazón puerta exterior	305.00
3	4120572A	Guarnizione a nastro 6 mm (5 mt.) per porta / Door strip gasket 6 mm (5 m) / Türbanddichtung 6 mm (5 m) / Joint ruban 6 mm (5 m) pour porte / Guarnición de cinta para puerta 6 mm (5 m)	33.00
3	4120572B	Guarnizione a nastro 6 mm (50 mt.) per porta / Door strip gasket 6 mm (50 m) / Türbanddichtung 6 mm (50 m) / Joint ruban 6 mm (50 m) pour porte / Guarnición de cinta para puerta 6 mm (50 m)	210.00
4	41701200100	Vetroceramico / Glass / Glaskeramikscheibe / Vitrocéramique / Cristal cerámico	205.00
5	41401249130V	Kit fermavetri - porta esterna / Glass fastening bracket kit - External door / Bausatz Haltebügel für Scheibebefestigung - Außentür / Kit etriers - porte extérieure / Equipo retendores del cristal - Puerta exterior	46.00
6	41801001500	Magnete / Magnet / Magnet / Aimant / Imán	39.00

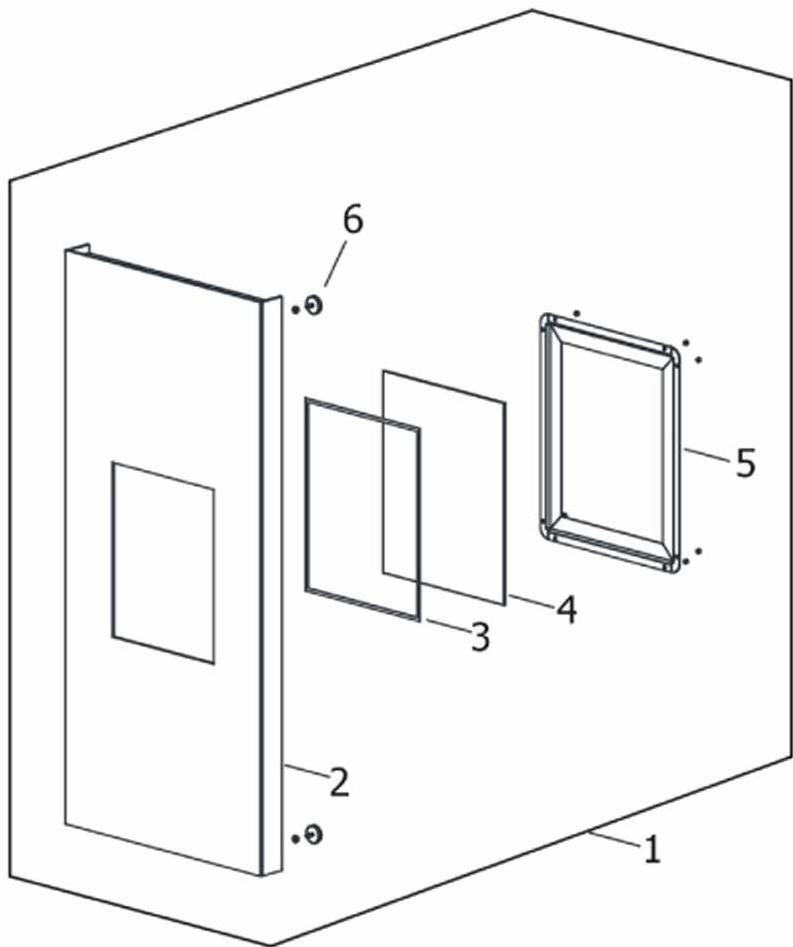

AIKE AIR OYSTER

Componenti interni meccanici ed elettronici / Electronic and mechanic internal parts / Interne mechanische und elektronische Bauteile / Composants internes mécaniques et électroniques / Componentes internos electrónicos y mecánicos

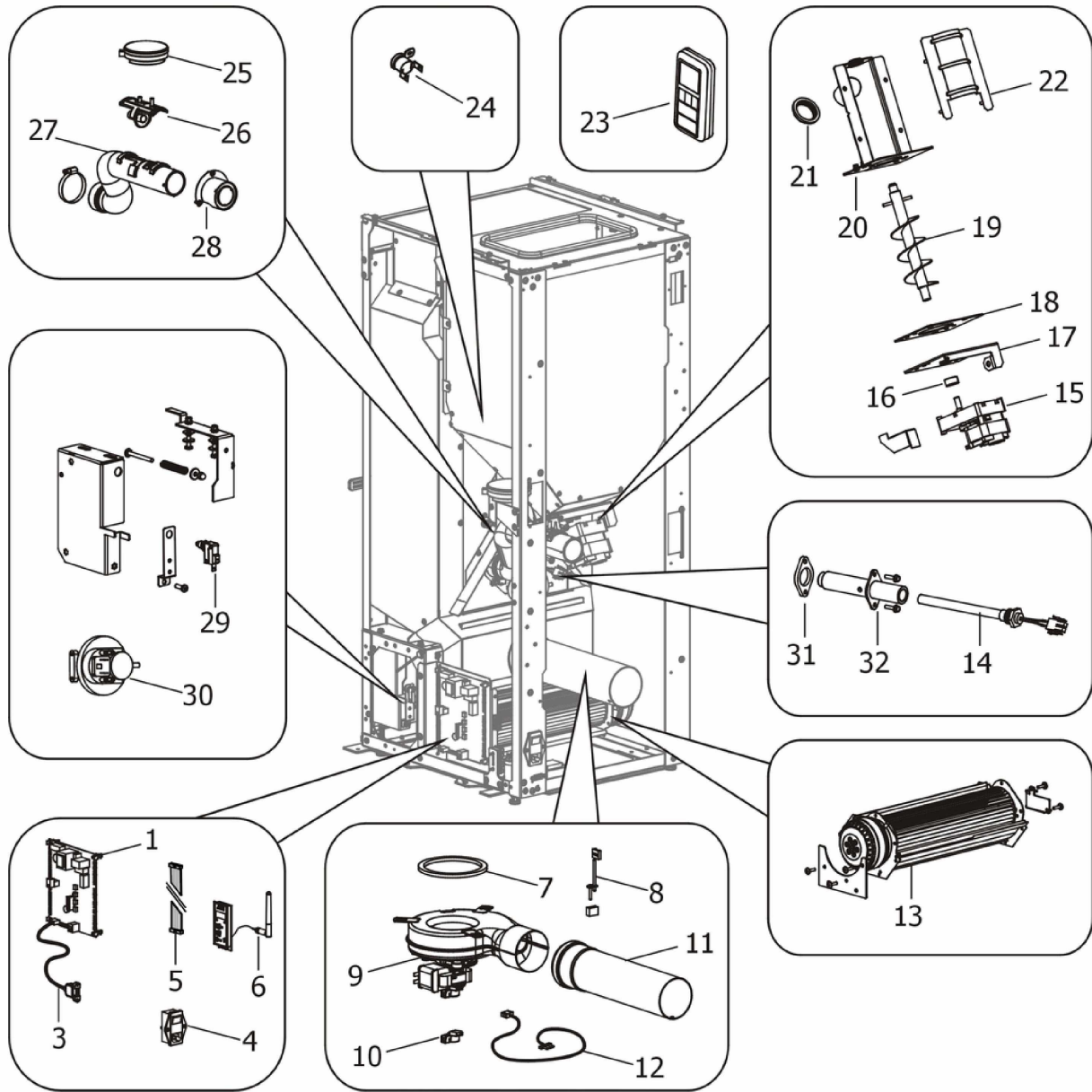

N°	Codice/Code	Descrizioni / Description / Beschreibung / Description / Descripción	Prezzo (€)
1	41451303805	Scheda madre Hottoh 148 / Hottoh motherboard 148 / Hauptplatine Hottoh 148 / Carte mère Hottoh 148 / Tarjeta madre Hottoh 148	170.00
1	41451303807	Scheda madre Hottoh 148 / Hottoh motherboard 148 / Hauptplatine Hottoh 148 / Carte mère Hottoh 148 / Tarjeta madre Hottoh 148	210.00
1	41801499750	Kit 868 / Kit 868 / Kit 868 / Kit 868 / Kit 868	192.00
3	41451403200	Cavo USB da pannello L.500 / USB Cable from display L.500 / USB Kabel von Notfalldisplay L.500 / Câble USB de panneau L.500 / Cable USB del panel L.500	21.00
4	4160193	Pulsante accensione / On/Off button / Zündungstaste / Touche d'allumage / Botón encendido	28.00
5	41450902500	Cavo flat / Flat cable / Flat-Kabel / Cable flat / Cable flat	20.00
6	41451404100	Pannello emergenza completo di antenna / Emergency display / Notfalldisplay mit Antenne / Panneau d'urgence avec antenne / Panel emergencia con antena	89.00
6	41451404700	Antenna 434 Mhz / Antenna 434 Mhz / Antenne 434 Mhz / Antenne 434 Mhz / Antena 434 Mhz	19.00

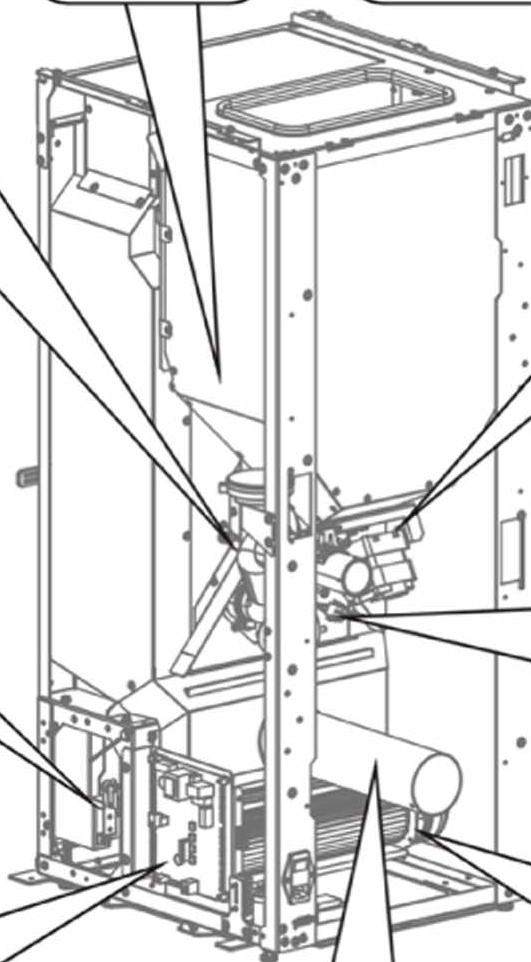
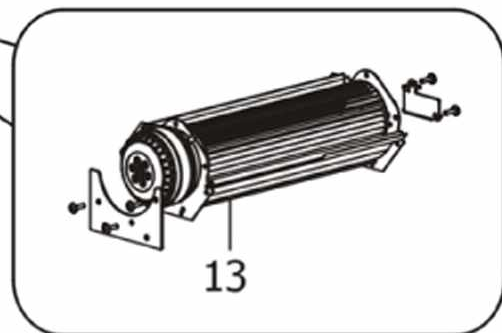
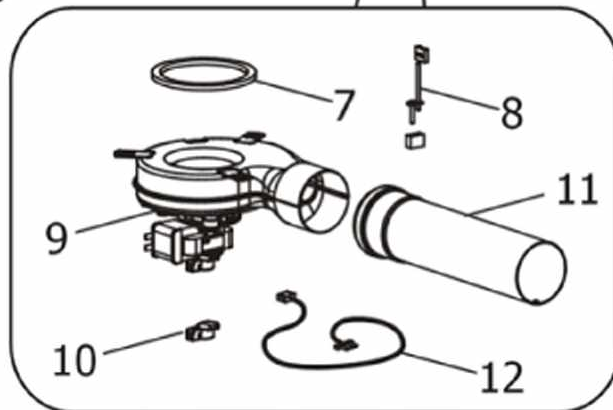
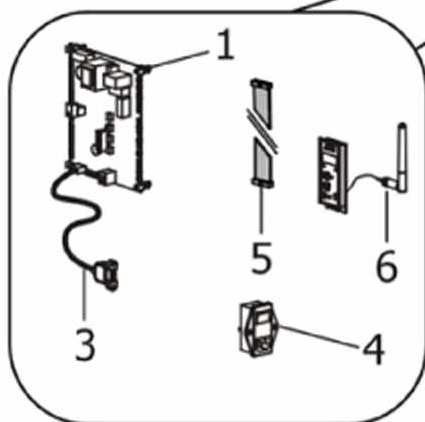
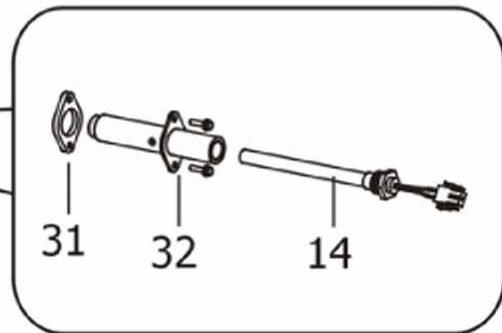
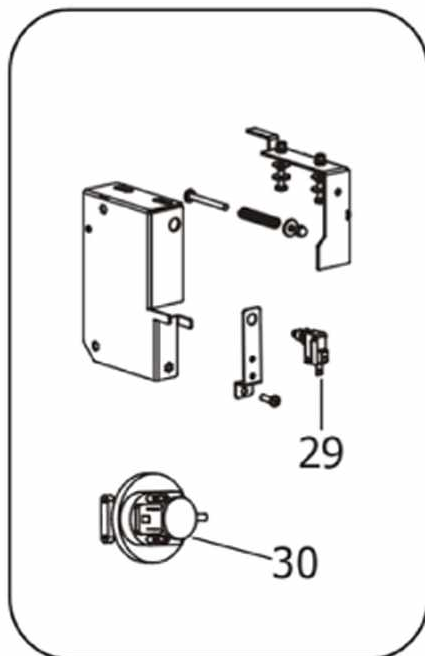
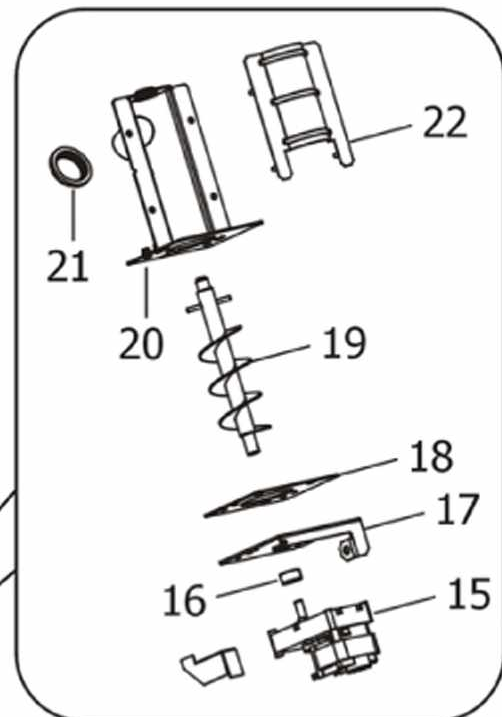
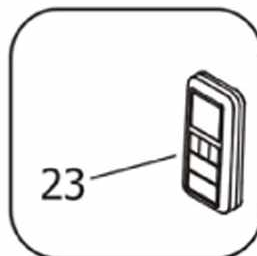
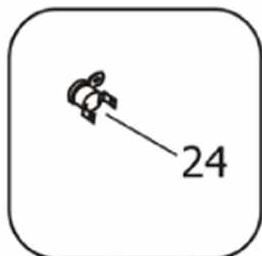
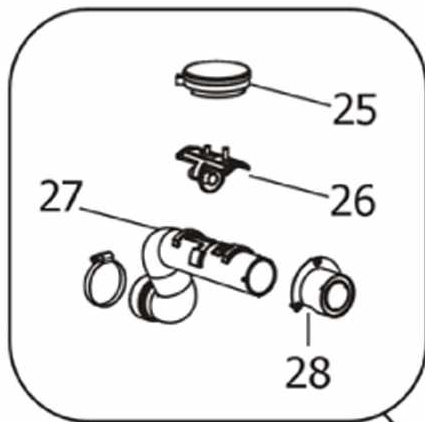

6	41801499750	Kit 868 / Kit 868 / Kit 868 / Kit 868 / Kit 868	192.00
7	41801002600	Guarnizione adesiva voluta fumi / Adhesive gasket smoke volute / Haftendichtung Rauchvolute / Joint adhesive volute fumées / Junta adhesiva voluta humos	20.00
8	41451404500	Sonda fumi con flangia / Smoke sensor with flange / Rauchsonde mit Flansche / Sonde fumées avec bride / Sonda humos con brida	25.00
9	41451406501	Ventilatore fumi / Smoke exhausted fan / Rauchgasgebläse / Ventilateur fumées / Ventilador humos	109.00
9	41801102500	Guarnizione / Gasket / Dichtung / Joint / Junta	21.00
9	41452009200	Encoder ventilatore / Fan encoder / Lüfter Encoder / Encodeur de ventilateur / Codificador de ventilador	17.00
10	41451209300	Encoder per ventilatore fumi marchi LN2/SIT / Encoder for LN2/SIT smoke fan / Encoder für LN2/SIT Rauchgasgebläse / Encoder pour ventilateur des fumées marques LN2/SIT / Encoder para ventilador humos marcas LN2/SIT	21.00
11	41601402860	Tubo fumi Ø 80 con guarnizione / Smoke pipe Ø 80 with gasket / Rauchrohr Ø 80 mit Dichtung / Tuyau fumées Ø 80 avec joint / Tubo humos Ø 80 con junta	37.00
12	41451501100	Cablaggio completo / Complete wiring / Komplette Verkabelung / Câblage complet / Cableado completo	84.00
12	41451700800	Cavo encoder / Encoder cable / Drehzahlmesser kabel / Câble encoder / Cable codificador	29.00
13	41451501200	Ventilatore aria / Air fan / Luftgebläse / Ventilateur air / Ventilador aire	148.00
14	41451401800	Candeletta 350 Watt / Sparkplug 350 Watt / Zündkerze 350 Watt / Bougie 350 Watt / Bujía 350 Watt	48.00
14	41801599250	Kit 50 candeletta 350 Watt / 50 Sparkplugs 350 Watt kit / Bausatz 50 Zündkerzen 350 Watt / Kit 50 Bougies 350 Watt / Kit 50 Bujías 350 Watt	1,920.00
15	41451301300	Motoriduttore 1,5 RPM C/ENCODER / Reduction motor 1,5 RPM + ENCODER / Getriebemotor 1,5 RPM + ENCODER / Motoréducteur 1,5 RPM + ENCODER / Motorreductor 1,5 RPM + ENCODER	116.00
16	4120398	Connettore motoriduttore-coclea / Reduction motor-feed screw connector / Verbindung Getriebemotor-Schnecke / Connecteur motoréducteur-vis sans fin / Conector motorreductor-cóclea	22.00
17	41401421340	Base coclea con boccia / Feed screw base with bush / Untergestell der Förderschnecke mit Buchse / Base de la vis sans fin avec douille / Base de la cóclea con abrazadera	64.00
18	4120615	Guarnizione base della coclea / Feed screw base gasket / Dichtung Untergestell der Förderschnecke / Joint pour la base de la vis sans fin / Junta base de la cóclea	19.00
19	41201301040	Coclea di caricamento pellet / Pellet feed screw / Pellet Förderschnecke / Vis sans fin pour chargement du pellet / Cóclea de carga pellet	48.00
20	41401421140V	Condotto della coclea / Feed screw conduit / Rohrleitung der Förderschnecke / Conduit de la vis sans fin / Conducto de la cóclea	86.00
21	41801210100	Guarnizione / Gasket / Dichtung / Joint / Junta	20.00
22	41401202140	Coperchio coclea / Feed screw cover / Deckel der Rohrleitung / Couvercle de la vis sans fin / Tapa de la cóclea	35.00
23	41451301203	Telecomando nero 434,5MHZ - Funzione impostabile da 0 a 3 Ventilatori / Black remote control 434,5MHZ - From 0 to 3 fan function / Schwarze Fernbedienung 434,5MHZ - Von 0 bis 3-Gebläse-Steuerung / Télécommande noire 434,5MHZ - Fonctionne à partir de 0 à 3 Ventilateurs / Mando a distancia negro 434,5MHZ - Función de 0 a 3 ventiladores	123.00
23	41801499750	Kit 868 / Kit 868 / Kit 868 / Kit 868 / Kit 868	192.00
24	412007004	Clickson 110°C / Clickson 110°C / Clickson 110°C / Clickson 110°C / Clickson 110°C	20.00
25	41451303400	Trasduttore di pressione / Pressure transducer / Active-Wandler / Transducteur de pression / Transductor de pression	58.00
26	41601301850	Componente rilevamento portata aria / Air flow measure component / Bauteil für Messung der Luftmenge / Composent pour la mesuration de la quantité d'air / Componente por la medida de l'aire	34.00
27	41801400800	Tubo ingresso aria in gomma / Rubber air inlet pipe / Lufteingangsrohr aus Gummi / Tuyau entrée d'air en caoutchouc / Tubo entrada aire de goma	31.00
28	41601404100P	Adattatore Ø 48/60 / Adapter Ø 48/60 / Adapter Ø 48/60 / Adapteur Ø 48/60 / Adaptador Ø 48/60	51.00
29	41451407100	Cavo Microswitch / Microswitch Cable / Microswitch Kabel / Câble Microswitch / Cable Microswitch	25.00
29	4160457	Pulsante per l'interruzione dell'alimentazione elettrica / power supply on-off button / Taste zur Unterbrechung der Stromversorgung / Bouton d'arrêt de l'alimentation électrique / Botón de corte de la alimentación eléctrica	20.00
30	41451003700	Pressostato / Pressure switch / Druckschalter / Pressostat / Presostat	40.00
31	41801404200	Guarnizione condotto candeletta / Sparkplug conduit gasket / Dichtung Zündkerzenkanal / Joint conduit bougie / Junta conducto bujía	22.00
32	41201410640V	Condotto candeletta / Sparkplug conduit / Zündkerzenkanal / Conduit bougie / Conducto bujía	45.00