

BERG

Rivestimenti esterni / External cladding / Externe Verkleidung / Habillage externe / Revestimiento externo

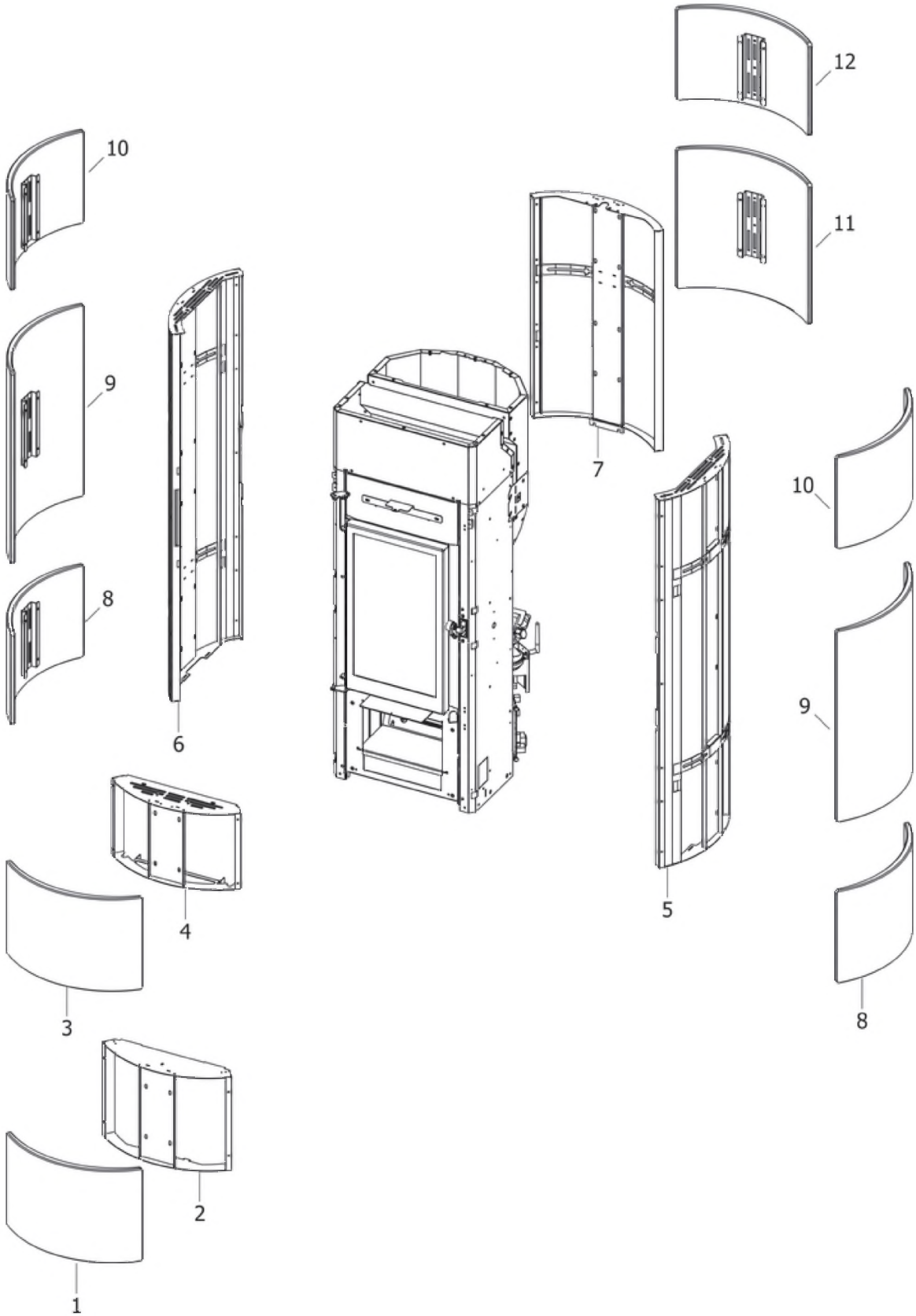

N°	Codice/Code	Descrizioni / Description / Beschreibung / Description / Descripcion	Prezzo (€)
1	41251603650	Pietra inferiore Serpentino / Lower Serpentine stone / Untere Stein aus Serpentino / Pierre inférieure Serpentine / Piedra inferior Serpentino	210.00
2	41411626840P	Telaio inferiore nero / Black lower frame / Schwarz untere Rahmen / Cadre inferieur noir / Armazón inferior negro	79.00
3	41251603750	Pietra superiore Serpentino / Upper Serpentine stone / Obere Stein aus Serpentino / Pierre supérieur Serpentine / Piedra superior Serpentino	212.00
4	41411627540P	Telaio superiore nero / Black upper frame / Schwarz obere Rahmen / Cadre supérieur noir / Armazón superior negro	87.00
5	41411625440P	Telaio laterale nero / Black lateral frame / Schwarz seitliche Rahmen / Cadre latéral noir / Armazón lateral negro	147.00
6	41411625440P	Telaio laterale nero / Black lateral frame / Schwarz seitliche Rahmen / Cadre latéral noir / Armazón lateral negro	147.00
7	41411626140P	Telaio supporto ceramica posteriore / Rear ceramic support frame / Hinterekeramik Rahmen / Cadre céramique postérieure / Armazón cerámica posterior	211.00
8	41251603650	Pietra inferiore Serpentino / Lower Serpentine stone / Untere Stein aus Serpentino / Pierre inférieure Serpentine / Piedra inferior Serpentino	210.00
8	41251603650	Pietra inferiore Serpentino / Lower Serpentine stone / Untere Stein aus Serpentino / Pierre inférieure Serpentine / Piedra inferior Serpentino	210.00
9	41251603850	Pietra laterale Serpentino / Lateral Serpentine stone / Seitliche Stein aus Serpentino / Pierre latérale Serpentine / Piedra lateral Serpentino	379.00
9	41251603850	Pietra laterale Serpentino / Lateral Serpentine stone / Seitliche Stein aus Serpentino / Pierre latérale Serpentine / Piedra lateral Serpentino	379.00
10	41251603750	Pietra superiore Serpentino / Upper Serpentine stone / Obere Stein aus Serpentino / Pierre supérieur Serpentine / Piedra superior Serpentino	212.00
10	41251603750	Pietra superiore Serpentino / Upper Serpentine stone / Obere Stein aus Serpentino / Pierre supérieur Serpentine / Piedra superior Serpentino	212.00
11	41251603950	Pietra posteriore Serpentino / Rear Serpentine stone / Hintere Stein aus Serpentino / Pierre postérieur Serpentine / Piedra posterior Serpentino	290.00
12	41251603750	Pietra superiore Serpentino / Upper Serpentine stone / Obere Stein aus Serpentino / Pierre supérieur Serpentine / Piedra superior Serpentino	212.00

BERG

Componenti Struttura Esterna / External structure components / Bauteile Aussenkorpus / Composants structure externe / Componentes estructura externa

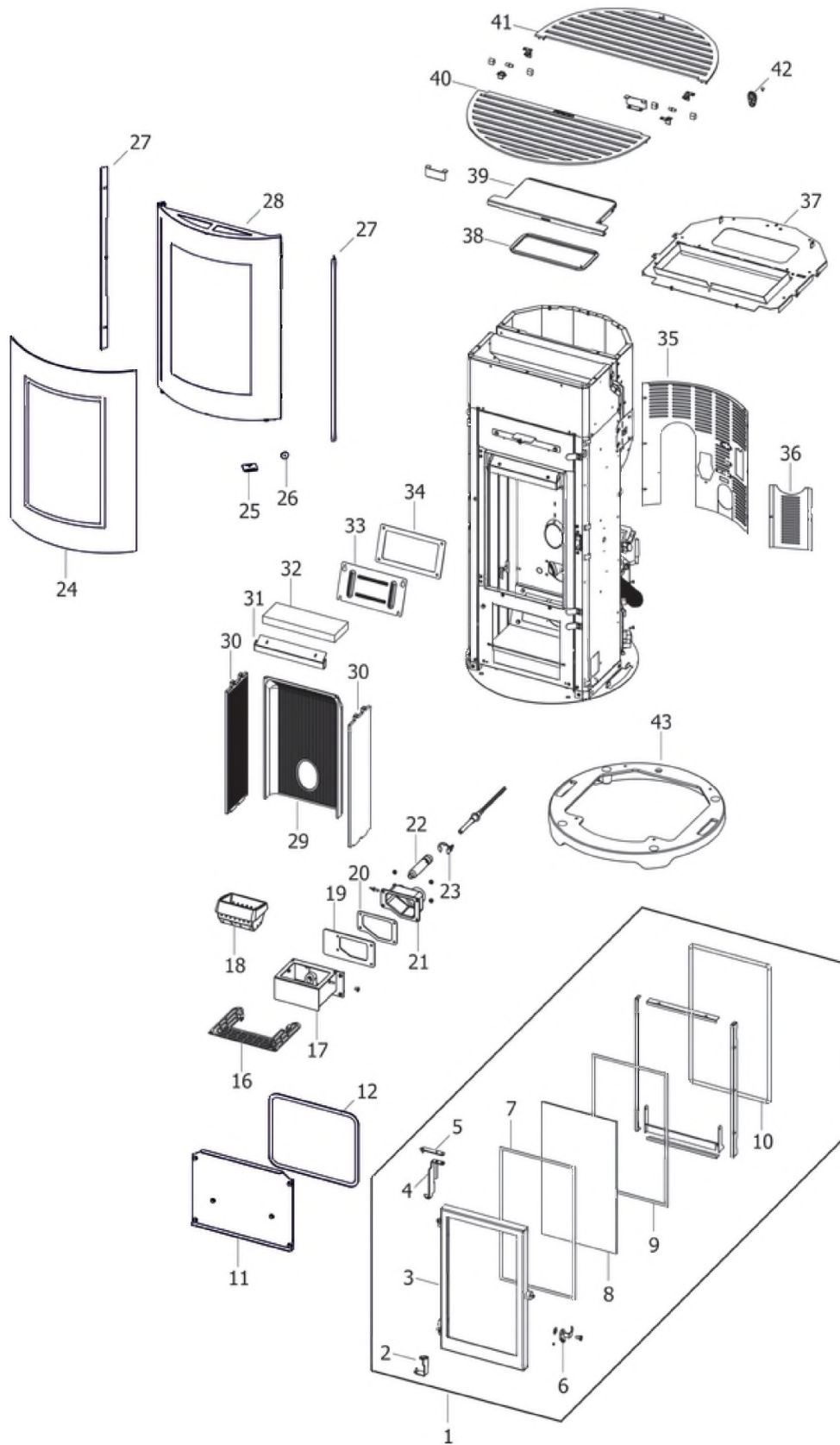

N°	Codice/Code	Descrizioni / Description / Beschreibung / Description / Descripcion	Prezzo (€)
1	437016055	Porta focolare in lamiera / Metal sheet fire door / Feuerstelle Tür / Porte foyer / Puerta hogar	297.00
1	437017082	Porta fuoco in ghisa / Cast iron fireplace door / Feuertür aus Gusseisen / Porte foyer en fonte / Puerta hogar de arrabio	208.00
2	41411614740V	Cerniera inferiore nera / Black lower hinge / Schwarzes unteres Scharnier / Charnière inférieure noire / Bisagra inferior negra	25.00
2	41411730740V	Cerniera inf.porta ghisa / Lower hinge for cast iron door / Unterer Scharnier für Tür aus Guß / Charnière inférieur pour porte en fonte / Bisagra inferior por porta en arrabio	27.00
3	41421600941V	Telaio porta fuoco / Fire door frame / Feuertürrahmen / Cadre porte foyer / Armazón puerta de arrabio	86.00
3	41301602500V	Telaio porta fuoco / Fire door frame / Feuertürrahmen / Cadre porte foyer / Armazón puerta de arrabio	78.00
4	41411614830V	Cerniera superiore sera / Black upper hinge / Schwarzes oberes Scharnier / Charnière supérieure noire / Bisagra superior negra	23.00
4	41411730840V	Cerniera superiore / Upper hinge / Oberes Scharnier / Charnière supérieure / Bisagra superior	30.00
5	41411614940V	Blocco cerniera superiore / Upper hinge stop / Obere Scharnierstopper / Stop charnière supérieure / Tope bisagra superior	27.00
6	41411616560	Maniglia porta nera / Door Handle / Türgriff / Poignée porte / Tirador	27.00
7	4120573A	Guarnizione a nastro 8 mm (5 mt.) per porta / Door strip gasket 8 mm (5 m) / Türbanddichtung 8 mm (5 m) / Joint ruban 8 mm (5 m) pour porte / Guarnición de cinta para puerta 8 mm (5 m)	32.00
7	4120573B	Guarnizione a nastro 8 mm (50 mt.) per porta / Door strip gasket 8 mm (50 m) / Türbanddichtung 8 mm (50 m) / Joint ruban 8 mm (50 m) pour porte / Guarnición de cinta para puerta 8 mm (50 m)	162.00
7	41801603300A	Guarnizione Ø5 5mt / Gasket Ø5 5mt / Dichtung Ø5 5mt / Joint Ø5 5mt / Junta Ø5 5mt	42.00
7	41801603300B	Guarnizione Ø5 50mt / Gasket Ø5 50mt / Dichtung Ø5 50mt / Joint Ø5 50mt / Junta Ø5 50mt	299.00
7	41801603300C	Guarnizione Ø5 5mt + silicone / Gasket Ø5 5mt + silic / Dichtung Ø5 5mt + Silikon / Joint Ø5 5mt + silic / Junta Ø5 5mt	63.00
8	41701600200	Vetroceramico / Glass / Glaskeramikscheibe / Vitrocéramique / Cristal cerámico	90.00
8	41701600300	Vetroceramico porta ghisa / Cast iron door glass / Glaskeramikscheibe Tür aus Gusseise / Vitrocéramique porte en fonte / Cristal cerámico puerta en arrabio	79.00
9	4120573A	Guarnizione a nastro 8 mm (5 mt.) per porta / Door strip gasket 8 mm (5 m) / Türbanddichtung 8 mm (5 m) / Joint ruban 8 mm (5 m) pour porte / Guarnición de cinta para puerta 8 mm (5 m)	32.00
9	4120573B	Guarnizione a nastro 8 mm (50 mt.) per porta / Door strip gasket 8 mm (50 m) / Türbanddichtung 8 mm (50 m) / Joint ruban 8 mm (50 m) pour porte / Guarnición de cinta para puerta 8 mm (50 m)	162.00
10	4120104A	Cordino fibrocaramico Ø 12 mm (5 mt.) / Ceramic fibre cord Ø 12 mm (5 m.) / Keramikfaserschnur Ø 12 mm (5 m) / Cordon en fibre céramique Ø 12 mm (5 m) / Junta a cuerda de fibra cerámica Ø 12 mm (5 m)	36.00
10	4120104B	Cordino fibrocaramico Ø 12 mm (50 mt.) / Ceramic fibre cord Ø 12 mm (50 m.) / Keramikfaserschnur Ø 12 mm (50 m) / Cordon en fibre céramique Ø 12 mm (50 m) / Junta a cuerda de fibra cerámica Ø 10 mm (52 m)	210.00
10	41201041	Kit sostituzione cordino (cordino+silicone) Ø 12 mm / Cord replacement kit (cord + silicone) Ø 12 mm / Schnuraustauschsatz (Schnur+Silikon) Ø 12 mm / Kit remplacement cordon (cordon + silicone) Ø 12 mm / Kit sustitución junta a cuerda (junta a cuerda+silicón) Ø 12 mm	50.00
11	437016050	Tappo inferiore / Lower cover / Untere Abdeckung / Couvercle inférieur / Tapón inferior	35.00
12	4120573A	Guarnizione a nastro 8 mm (5 mt.) per porta / Door strip gasket 8 mm (5 m) / Türbanddichtung 8 mm (5 m) / Joint ruban 8 mm (5 m) pour porte / Guarnición de cinta para puerta 8 mm (5 m)	32.00
12	4120573B	Guarnizione a nastro 8 mm (50 mt.) per porta / Door strip gasket 8 mm (50 m) / Türbanddichtung 8 mm (50 m) / Joint ruban 8 mm (50 m) pour porte / Guarnición de cinta para puerta 8 mm (50 m)	162.00
16	41411613630V	Griglia focolare / Fire box grille / Feuerstellenrost / Grille foyer / Rejilla hogar	31.00
17	41411613140V	Tasca braciere / Combustion pot container / Brenntopfkasten / Récipient brasero / Contenedor brasero	79.00
18	41301502400V	Braciere ghisa / Cast iron grate / Brenntopf aus Gusseisen / Brasero en fonte / Brasero en arrabio	51.00
19	41801601500	Guarnizione tasca braciere / Combustion pot container gasket / Brenntopfkasten Dichtung / Joint récipient brasero / Junta contenidor brasero	18.00
20	41801602300	Guarnizione codolo / Gasket / Dichtung / Joint / Junta	19.00
21	41311600100	Codolo / Tool chuck / Einspannschaft / Outil d'emmanchement / Mango	29.00
22	41601601000	Condotto candeletta / Sparkplug Conduit / Zündkerzenkanal / Conduit Bougie / Conducto Bujía	27.00
23	41201601500	Anello arresto candeletta / Sparkplug stop / Zündkerzestopper / Butée bougie / Tope bujía	24.00
24	41701500660	Vetroceramico / Ceramic glass / Glaskeramikscheibe / Vitre céramique / Cristal cerámico	424.00
24	41701802100	Vetro temperato / Tempered glass / Gehärtete Glasscheibe / Vitre trempé / Cristal templado	173.00
25	41411617360	Maniglia porta esterna nera / External door handle / Außentür Griff / Poignée porte extérieure / Tirador puerta exterior	18.00
26	41801657900	Magneti (pz.2) / Magnet (pcs.2) / Magnet (stk. 2) / Aimant (pcs.2) / Imán (pz.2)	22.00

27	41411617230P	Fermavetro per vetro ceramico / Glass fastening bracket for feramic glass / Haltebügel für Scheibebefestigung für Glaskeramikscheibe / Etrier de fixation vitre pour vitre céramique / Retendor del cristal para cristal cerámico	27.00
27	41411617230P	Fermavetro per vetro ceramico / Glass fastening bracket for feramic glass / Haltebügel für Scheibebefestigung für Glaskeramikscheibe / Etrier de fixation vitre pour vitre céramique / Retendor del cristal para cristal cerámico	27.00
27	4141161723100	Fermavetro per vetro temperato / Glass fastening bracket for tempered glass / Haltebügel für Scheibebefestigung für gehärtete Glasscheibe / Etrier de fixation vitre pour vitre trempé / Retendor del cristal para cristal templado	26.00
27	4141161723100	Fermavetro per vetro temperato / Glass fastening bracket for tempered glass / Haltebügel für Scheibebefestigung für gehärtete Glasscheibe / Etrier de fixation vitre pour vitre trempé / Retendor del cristal para cristal templado	26.00
28	41421601040V	Porta esterna / Complete External Door / Komplette Außentür / Porte Extérieure Complète / Puerta Exterior Completa	117.00
29	41301502600V	Schiena ghisa / Cast iron back / Rückwand aus Gusseisen / Dosseret en fonte / Parte trasera en arrabio	71.00
29	41411613530V	Deflettore pellet / Pellet deflector / Pellet Leitblech / Deflecteur pellet / Deflector pellet	23.00
30	41301502500V	Fianco ghisa / Cast iron side / Seite aus Guß / Côté en fonte / Placa lateral de arrabio	49.00
30	41301502500V	Fianco ghisa / Cast iron side / Seite aus Guß / Côté en fonte / Placa lateral de arrabio	49.00
31	41411615430V	Deflettore aria / Air deflector / Luftleitblech / Défecteur aire / Deflector aire	26.00
32	41151600200	Deflettore focolare in vermiculite / Vermiculite deflector / Leitblech aus Vermiculite / Défecteur en vermiculite / Deflector en vermiculite	22.00
33	41401339610	Tappo ispezione vano fumi / Smoke compartment inspection plug / Inspektionsdeckel Rauchabzug / Clapet inspection compartiment fumées / Tapón inspección compartimento humos	21.00
34	41800900600	Guarnizione / Gasket / Dichtung / Joint / Junta	21.00
34	41801599750	Kit 50 guarnizioni / Kit 50 gaskets / Bausatz 50 Dichtungen / Kit 50 joints / Kit 50 juntas	840.00
35	41411615140P	Pannello asportabile posteriore / Amovable rear panel / Abnehmbares hintere Paneel / Panneau postérieur démontable / Panel posterior desmontable	71.00
36	41411624230P	Flangia pannello ispezione nera / Inspection panel black flange / Inspektionklappe Schwarzflansch / Bride noir trappe inspection / Brida negra tapa inspección	25.00
37	41411614240V	Supporto top completo / Top support / Deckelhaltebügel / Support du dessus / Soporte top	75.00
38	41801601400	Guarnizione coperchio serbatoio / Pellet hopper cover gasket / Deckel Pelletbehälter Dichtung / Joint couvercle réservoir pellet / Junta tapa depósito pellet	21.00
39	437016053	Coperchio serbatoio / Hopper cover / Deckel Pelletbehälter / Couvercle réservoir / Tapa depósito	91.00
40	41411624340P	Top fisso nero / Top / Abdeckplatte / Dessous / Top	125.00
41	41411624640P	Top mobile nero / Black amovable top / Schwarze abnehmbares Deckel / TOP noir démontable / Top negroamovible	113.00
42	41801602200	Maniglia siliconica / silicone handle / Silikongriff / Poignée de silicone / Tirador de silicona	17.00
43	41301600900P	Basamento in ghisa / Cast iron base / Basis auf gusssein / Base en fonte / Base de arrabio	61.00

BERG

Rivestimenti esterni / External cladding / Externe Verkleidung / Habillage externe / Revestimiento externo

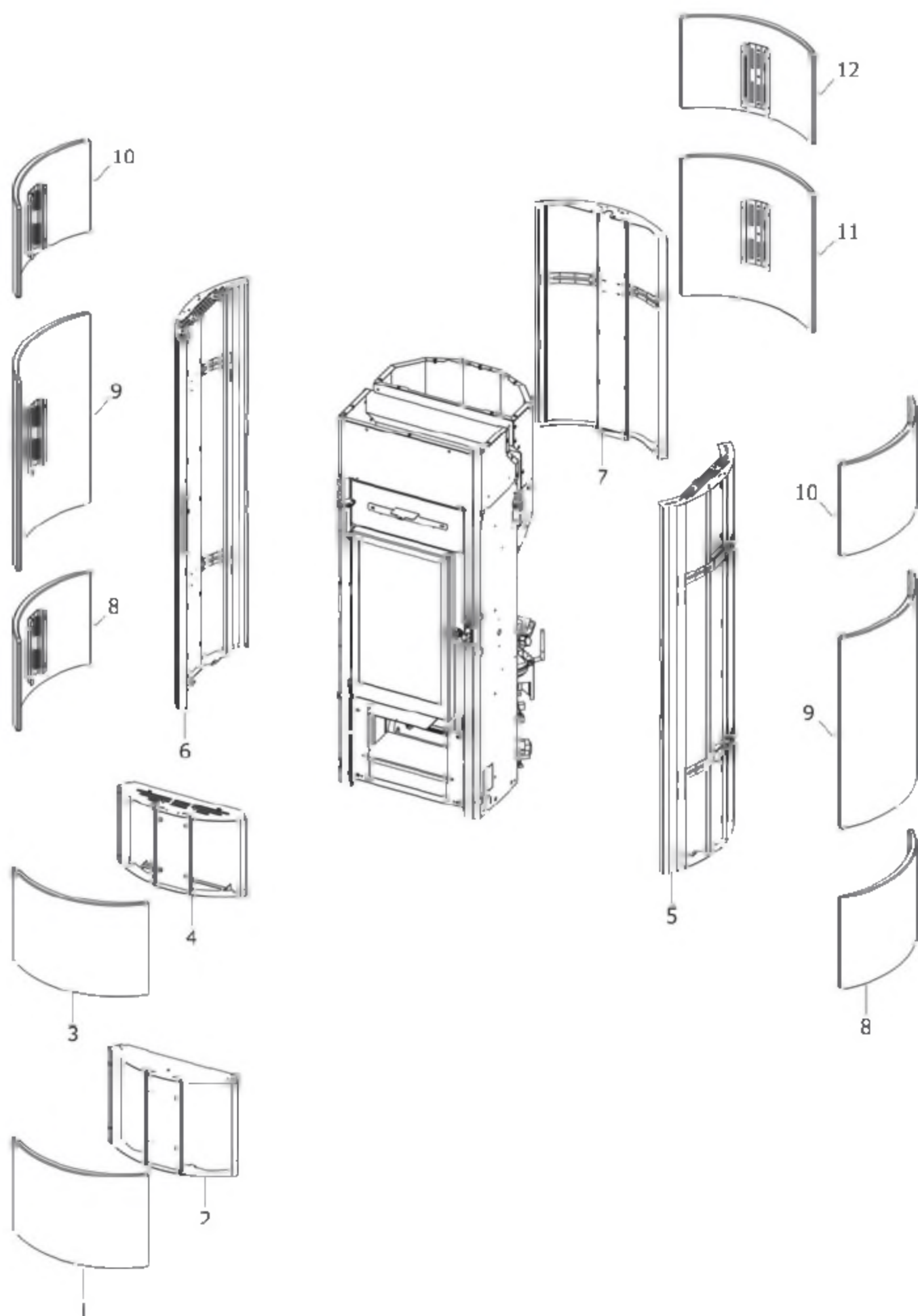

BERG

Componenti interni meccanici ed elettronici / Electronic and mechanic internal parts / Interne mechanische und elektronische Bauteile / Composants internes mécaniques et électroniques / Componentes internos electrónicos y mecánicos

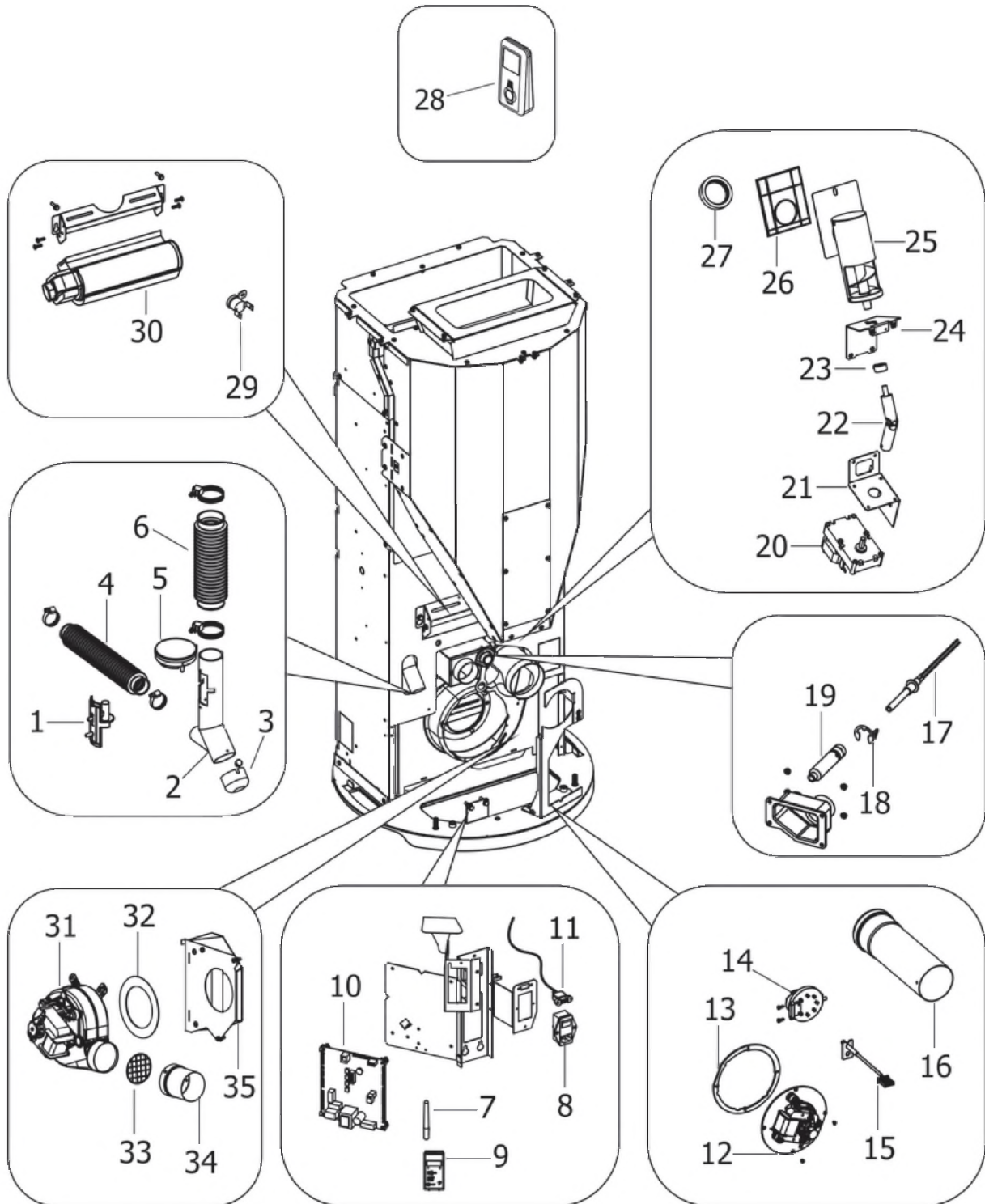

N°	Codice/Code	Descrizioni / Description / Beschreibung / Description / Description	Prezzo (€)
1	41601301850	Componente rilevamento portata aria / Air flow measure component / Bauteil für Messung der Luftmenge / Composent pour la mesuration de la quantité d'air / Componente por la medida de l'aire	34.00
2	41601601800V	Tubo aspirazione nero / Black air inlet pipe / Schwarz Lufteingangrohr / Tuyau entrée d'air noir / Tubo entrada aire negro	48.00

3	41401036100	Filtro antipolvere / Anti-dust filter / Staubschutzfilter / Filtre antipoussière / Filtro de protección polvo	21.00
4	41801601900	Tubo aspirazione pulizia vetro / Inlet pipe for cleaning glass air / Glassreinigungs Lufteingangrohr / Tuyau entrée pour l'aire de nettoyage du verre / Tubo entrada por l'aire de limpieza vidrio	62.00
5	41451303400	Trasduttore di pressione / Pressure transducer / Active-Wandler / Transducteur de pression / Transductor de pression	58.00
6	41801601700	Tubo aspirazione camera combustione / Combustion chamber aspiration tube / Verbrennungskammer Förderrohr / Tuyau aspiration air chambre de combustion / Tubo aspiración aire cámara de combustión	28.00
7	41451404700	Antenna 434 Mhz / Antenna 434 Mhz / Antenne 434 Mhz / Antenne 434 Mhz / Antena 434 Mhz	19.00
8	4160193	Pulsante accensione / On/Off button / Zündungstaste / Touche d'allumage / Boton encendido	28.00
9	41451404100	Pannello emergenza completo di antenna / Emergency display / Notfalldisplay mit Antenne / Panneau d'urgence avec antenne / Panel emergencia con antena	89.00
9	41801499750	Kit 868 / Kit 868 / Kit 868 / Kit 868 / Kit 868	192.00
10	41451303805	Scheda madre Hottoh 148 / Hottoh motherboard 148 / Hauptplatine Hottoh 148 / Carte mère Hottoh 148 / Tarjeta madre Hottoh 148	170.00
10	41451303807	Scheda madre Hottoh 148 / Hottoh motherboard 148 / Hauptplatine Hottoh 148 / Carte mère Hottoh 148 / Tarjeta madre Hottoh 148	210.00
10	41451600201	Cablaggio completo / Complete wiring / Komplette Verkabelung / Câblage complet / Cableado completo	82.00
10	41801499750	Kit 868 / Kit 868 / Kit 868 / Kit 868 / Kit 868	192.00
11	41451403200	Cavo USB da pannello L.500 / USB Cable from display L.500 / USB Kabel von Notfalldisplay L.500 / Câble USB de panneau L.500 / Cable USB del panel L.500	21.00
12	41451503200	Ventilatore fumi stagno / Air-tight smoke exhausted fan / Luftdichtes Rauchgasgebläse / Ventilateur fumées étanche / Ventilador humos hermético	82.00
12	41451703000	Encoder per ventilatore fumi marchio EBM / Encoder for EMB smoke fan / Encoder für EBM Rauchgasgebläse / Encoder pour ventilateur des fumées marque EBM / Encoder para ventilador humos marca EBM	22.00
12	41451209300	Encoder per ventilatore fumi marchi LN2/SIT / Encoder for LN2/SIT smoke fan / Encoder für LN2/SIT Rauchgasgebläse / Encoder pour ventilateur des fumées marques LN2/SIT / Encoder para ventilador humos marcas LN2/SIT	21.00
12	41452009200	Encoder ventilatore / Fan encoder / Lüfter Encoder / Encodeur de ventilateur / Codificador de ventilador	17.00
13	41801600800	Guarnizione ventilatore fumi / Smoke exhaust fan gasket / Dichtung Rauchabsauggebläse / Joint Ventilateur aspiration fumées / Junta ventilador aspiración humos	22.00
14	41451003700	Pressostato / Pressure switch / Druckschalter / Pressostat / Presostato	40.00
15	41451703600	Sonda fumi con flangia con morsetti L.980 / Smoke sensor with flange with terminal board L.980 / Rauchsonde mit Flansche mit Klemmbrett L.980 / Sonde fumées avec bride avec serre-câble L.980 / Sonda humos con brida con borne L.980	23.00
16	41601603000	Tubo Ø8 L.25 con guarnizione / Pipe Ø8 L.25 with gasket / Rohr Ø8 L.14 mit Dichtung / Tuyau Ø8 L.25 avec joint / Tubo Ø8 L.25 con guarnición	30.00
17	41451308101	Candeletta 315 Watt / Sparkplug 315 Watt / Zündkerze 315 Watt / Bougie 315 Watt / Bujía 315 Watt	77.00
17	41451308150	Kit 25 candeletta 315 Watt / 25 Sparkplugs 315 Watt kit / Bausatz 25 Zündkerzen 315 Watt / Kit 25 Bougies 315 Watt / Kit 25 Bujías 315 Watt	1,637.00
18	41201601500	Anello arresto candeletta / Sparkplug stop / Zündkerzestopper / Butée bougie / Tope bujía	24.00
19	41601601000	Condotto candeletta / Sparkplug Conduit / Zündkerzenkanal / Conduit Bougie / Conducto Bujía	27.00
20	41451503100	Motoriduttore 2rpm / Gear motor 2rpm / Getriebemotor 2rpm / Motoréducteur 2rpm / Motorreductor 2rpm	102.00
21	41401609830	Supporto motoriduttore / Reduction motor support / Schneckenmotor Gestell / Support motoréducteur / Soporte motoreductor	20.00
22	41801604200	Cardano / Cardan / Kardan / Cardan / Cardán	49.00
23	4120398	Connettore motoriduttore-coclea / Reduction motor-feed screw connector / Verbindung Getriebemotor-Schnecke / Connecteur motoréducteur-vis sans fin / Conector motorreductor-cóclea	22.00
24	41401609730	Supporto motoriduttore / Reduction motor support / Schneckenmotor Gestell / Support motoréducteur / Soporte motoreductor	20.00
25	41411800151	Gruppo alimentazione completo / Complete feed screw / Komplette Förderschnecke / Vis sans fin complète / Coclea de carga completa	113.00
26	41801600400	Guarnizione gruppo caricamento / Gasket / Dichtung / Joint / Junta	20.00
27	41801501900	Guarnizione silicone / Silicon gasket / Silikondichtung / Joint en silicone / Junta en silicóna	20.00
27	41801702600	Disaccoppiatore misc. Marrone / Brown disengaging device / Braun Verängungsrohr / Tuyau de découplage marron / Tubo de desvío marron	18.00
28	41451301203	Telecomando nero 434,5MHZ - Funzione impostabile da 0 a 3 Ventilatori / Black remote control 434,5MHZ - From 0 to 3 fan function / Schwarze Fernbedienung 434,5MHZ - Von 0 bis 3-Gebläse-Steuerung / Télécommande noire 434,5MHZ - Fonctionne à partir de 0 à 3 Ventilateurs / Mando a distancia negro 434,5MHZ - Función de 0 a 3 ventiladores	123.00

28	41801499750	Kit 868 / Kit 868 / Kit 868 / Kit 868 / Kit 868	192.00
29	412007004	Clickson 110°C / Clickson 110°C / Clickson 110°C / Clickson 110°C / Clickson 110°C	20.00
30	41451600800	Ventilatore aria / Air fan / Luftgebläse / Ventilateur air / Ventilador aire	76.00
31	41451503300	Ventilatore centrifugo / Air fun / Lufgebläse / Ventilateur air / Ventilador aire	76.00
32	41801601600	Guarnizione ventilatore / Fan gasket / Dichtung des Gebläses / Joint du ventilateur / Junta ventilador	17.00
33	41331600410	Griglia protezione prolunga ventilatore / Fan extension protection grille / Schutzgitter Gebläseverlängerung / Grille de protection prolongation ventilateur / Rejilla de protección prolongación ventilador	20.00
34	41601601700V	Prolunga ventilatore centrifugo / Fan extension / Gebläse Verlängerung / Rallonge ventilateur / Extensión ventilador	33.00
35	41401609230	Tamponazione completa / Complete filling / Komplett Stopfung / Tampon complét / Taponado completo	65.00