

COMPACT 14

Componenti Struttura Esterna / External structure components / Bauteile Aussenkorpus / Composants structure externe / Componentes estructura externa

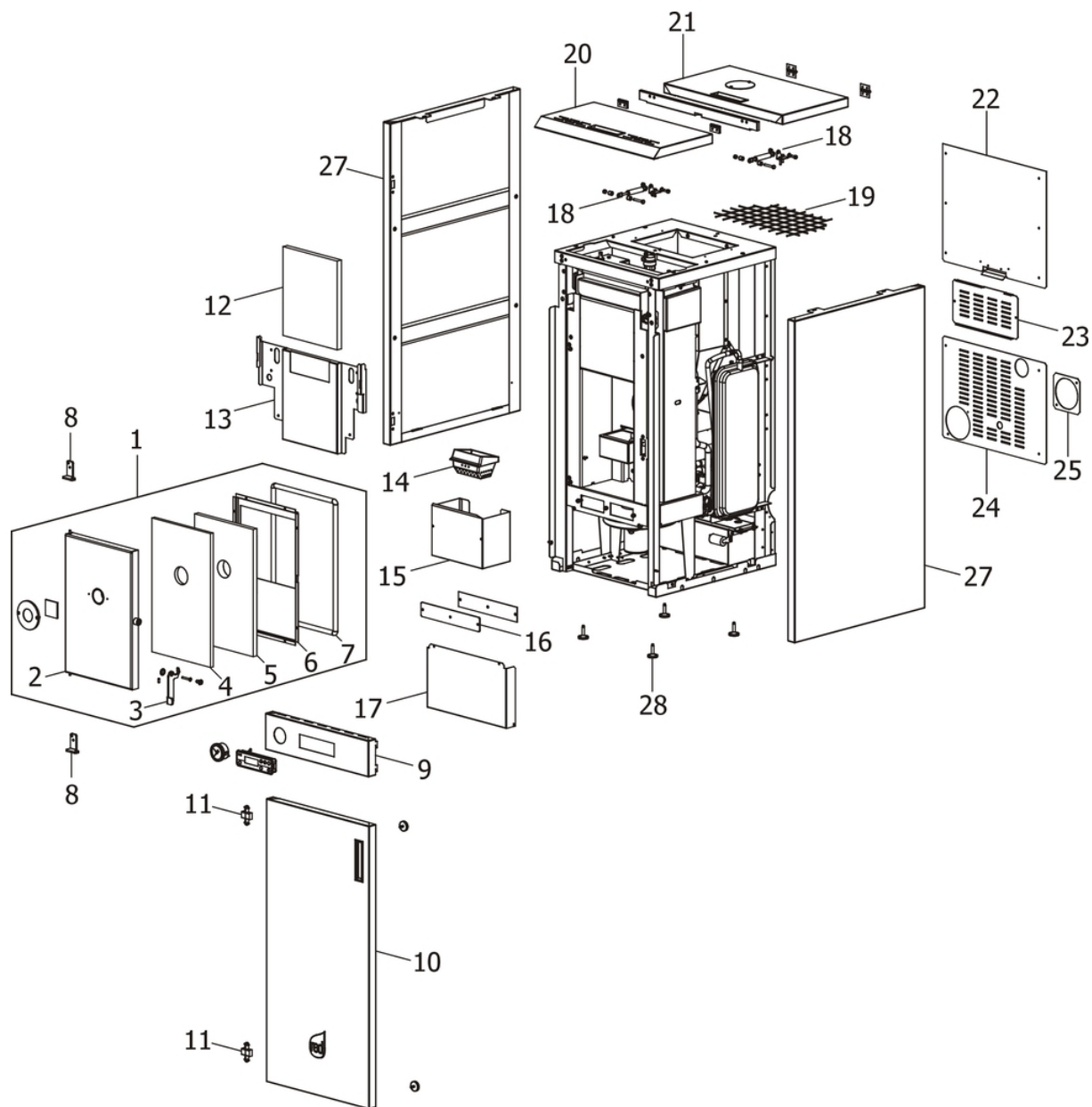

N°	Codice/Code	Descrizioni / Description / Beschreibung / Description / Descripción	Prezzo (€)
1	437013089	Porta finita completa / Complete finished door / Komplette Tür / Porte finie complète / Puerta completa	221.00
2	4140136640V	Telaio porta fuoco / Fire door frame / Feuertürrahmen / Cadre porte foyer / Armazón puerta de arrabio	96.00
3	41401133230V	Maniglia / Handle / Griff / Poignée / Tirador	21.00
4	41151301400	Isolante interno / Internal insulating material / Innerer Isolationsmaterial / Isolant intérieur / Aislante interno	36.00
5	41151301500	Vermiculite interna / Internal Vermiculite / Innere Vermiculite / Vermiculite intérieur / Vermiculite interna	48.00
6	41401366930	Tamponazione interna porta fuoco / Fire door inner filling / Interne Abdichtung Feuerraumtür / Tampon interne de la porte du foyer / Taponado interno de la puerta hogar	33.00
7	412007003A	Cordino fibroceramico Ø 14 mm (5 mt.) / Ceramic fibre cord Ø 14 mm (5 m.) / Keramikfaserschnur Ø 14 mm (5 m) / Cordon en fibre céramique Ø 14 mm (5 m) / Junta a cuerda de fibra cerámica Ø 14 mm (5 m)	43.00
7	412007003B	Cordino fibroceramico Ø 14 mm (50 mt.) / Ceramic fibre cord Ø 14 mm (50 m.) / Keramikfaserschnur Ø 14 mm (50 m) / Cordon en fibre céramique Ø 14 mm (50 m) / Junta a cuerda de fibra cerámica Ø 14 mm (50 m)	300.00
7	412007003C	Kit sostituzione cordino (cordino+silicone) Ø 14 mm / Cord replacement kit (cord + silicon) Ø14 mm / Schnuraustauschsatz (Schnur +Silikon) Ø 14 mm / Kit remplacement cordon (cordon+silicon) Ø 14 / Kit sustitución	69.00

		junta a cuerda (junta a cuerda+silicón) Ø 14 mm	
8	41401366230V	Cerniera superiore/inferiore / Upper/lower hinge / Oberes/unteres Scharnier / Charnière supérieure/inférieure / Bisagra superior/inferior	22.00
8	41401366230V	Cerniera superiore/inferiore / Upper/lower hinge / Oberes/unteres Scharnier / Charnière supérieure/inférieure / Bisagra superior/inferior	22.00
9	41401367560	Frontale in acciaio / Steel frontal panel / Fassade aus Stahl / Panneau frontal en acier / Frontal en acero	42.00
10	41401367950	Porta frontale / Frontal door / Vordere Tür / Porte frontal / Puerta frontal	169.00
11	41201501700	Cerniera Pz.2 / Hinge Pcs.2 / Scharnier Stk.2 / Charnière Pcs.2 / Bisagra Pz.2	37.00
12	41151301300	Pannello isolante caldaia / Insulating panel of the boiler / Dämmplatte des Kessels / Panneau isolant de la chaudière / Panel aislante de la caldera	27.00
13	41401366330	Supporto pannello isolante caldaia / Boiler insulating panel support / Dämmplatteunterstützung des Kessels / Support panneau isolant chaudière / Soporte panel aislante caldera	38.00
14	413008003	Braciere completo in ghisa / Cast iron complete grate / Kompletter Brennertopf aus Gusseisen / Brasero complet en fonte / Brasero completo de arrabio	47.00
15	41401365630	Cassetto cenere / Ash drawer / Aschenkasten / Tiroir à cendres / Cajón ceniza	39.00
16	41801301600	Guarnizione tappo ispezione vano fumi / Smoke compartment inspection plug gasket / Dichtung Inspektionskappe Rauchabzug / Joint clapet inspection compartiment fumées / Junta tapón inspección compartimento humos	21.00
17	41401367630	Tamponazione inferiore / Lower filling / Untere Abdichtung / Tampon interne inférieure / Taponado inferior	26.00
18	41801101400	Pistone a gas / Gas-piston / Gas-Kolben / Piston à gaz / Pistón a gas	44.00
18	41801101400	Pistone a gas / Gas-piston / Gas-Kolben / Piston à gaz / Pistón a gas	44.00
19	41400904100	Griglia protezione serbatoio / Hopper protection grille / Schutzgitter Pelletbehälter / Grille de protection réservoir / Rejilla de protección depósito	21.00
20	41401368350	Coperchio anteriore / Front Door / Fronttür / Couvercle antérieur / Puerta frontal	108.00
21	41401368850	Coperchio serbatoio pellet / Pellet hopper cover / Deckel Pelletbehälter / Couvercle réservoir pellet / Tapadera depósito pellet	74.00
22	41401366410	Schiena superiore in acciaio / Steel upper back / Obere Rückwand aus Stahl / Dosseret supérieur en acier / Panel trasero superior de acero	29.00
23	41401366030	Copertura scheda elettronica / Motherboard cover / Abdeckung für Hauptplatine / Panneau de couverture du carte mère / Cobertura de la placa base	27.00
24	41401366510	Schiena inferiore in acciaio / Steel lower back / Untere Rückwand aus Stahl / Dosseret inférieur en acier / Panel trasero inferior en acero	41.00
25	41401170010	Flangia / Flange / Flansch / Bride / Brida	18.00
27	41401367750	Fianco acciaio DX-SX / R.-L. steel side / RE.-LI. Stahlaussenseite / Côté D-G en acier / Lateral en acero DCHO-IZDO	150.00
27	41401367750	Fianco acciaio DX-SX / R.-L. steel side / RE.-LI. Stahlaussenseite / Côté D-G en acier / Lateral en acero DCHO-IZDO	150.00
28	4120618	Piedini di appoggio (4 pz) / Support feet (4 pcs) / Einstellfüße (4 Stck) / Vérins d'appui (4 pcs) / Pies de apoyo (4 pz)	19.00

COMPACT 14

Componenti interni meccanici ed elettronici / Electronic and mechanic internal parts / Interne mechanische und elektronische Bauteile / Composants internes mécaniques et électroniques / Componentes internos electrónicos y mecánicos

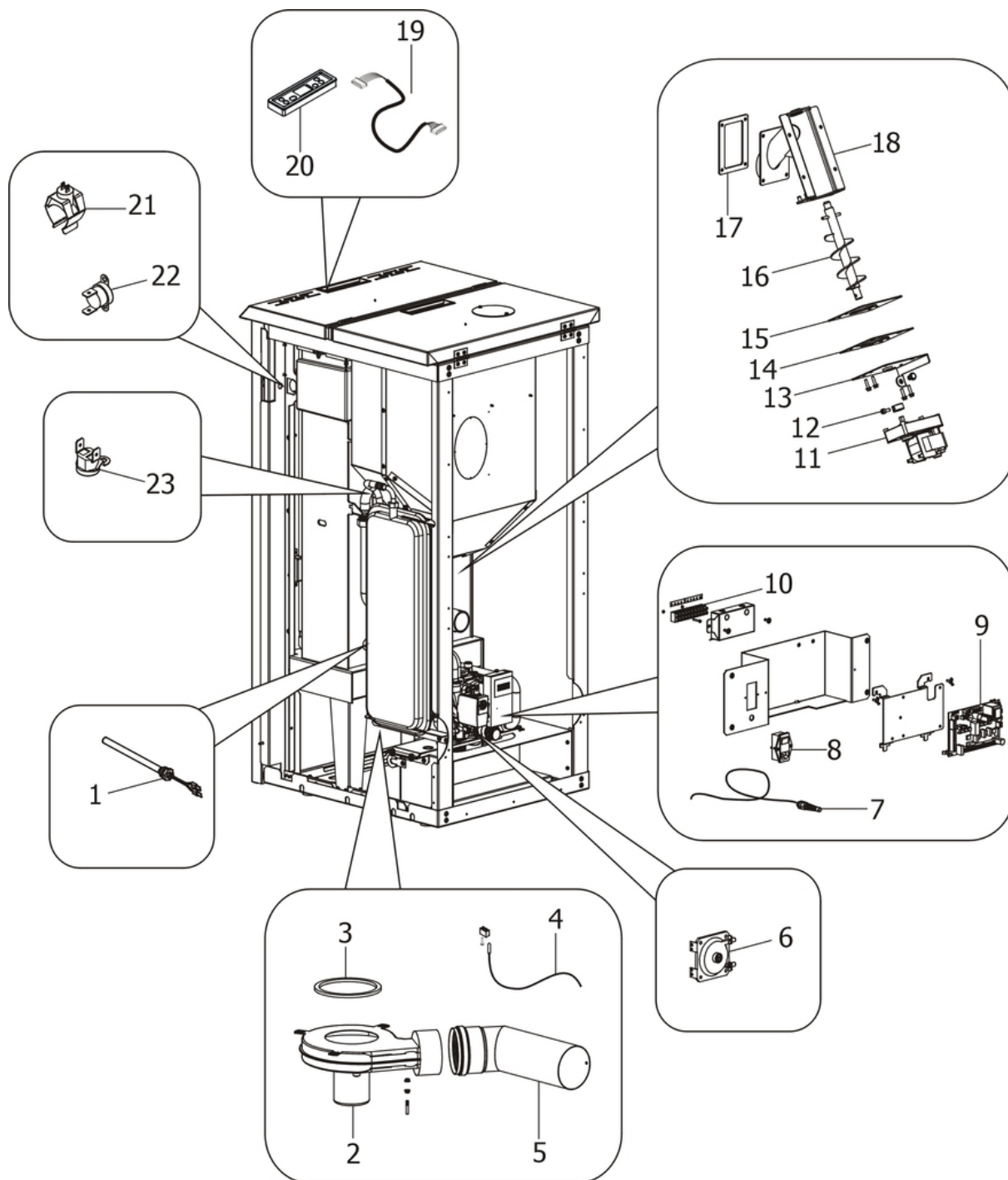

N°	Codice/Code	Descrizioni / Description / Beschreibung / Description / Descripción	Prezzo (€)
1	41450905000	Candeletta accensione pellet / Pellet ignition sparkplug / Zündkerze Pelletzündung / Bougie d'allumage pellet / Bujía encendido pellet	41.00
1	41801599550	Kit 50 candelette / 50 Sparkplugs kit / Bausatz 50 Zündkerzen / Kit 50 Bougies / Kit 50 Bujías	1,638.00
2	41451201750	Ventilatore fumi / Smoke exhaust fan / Rauchabsauggebläse / Ventilateur aspiration fumées / Ventilador aspiración de humos	224.00
3	41801100100	Guarnizione adesiva voluta fumi / Adhesive gasket smoke volute / Haftendichtung Rauchvolute / Joint adhesive volute fumées / Junta adhesiva voluta humos	20.00

4	41451002300	Sonda fumi con flangia / Smoke sensor with flange / Rauchgasfühler mit Flansche / Sonde fumées avec bride / Sonda humos con arandela	30.00
5	41601303400	Tubo uscita fumi / Smoke outlet pipe / Rohr Rauchabzug / Tuyau sortie fumées / Tubo salida humos	51.00
6	414508040	Pressostato 1.2 mbar / Pressure switch 1.2 mbar / Druckwächter 1.2 mbar / Pressostat 1.2 mbar / Presostato 1.2 mbar	38.00
7	4160386	Sonda temperatura ambiente/acqua / Room/Water temperature sensor / Raum- Wassertemperaturfühler / Sonde température ambiente/eau / Sonda temperatura ambiente/agua	20.00
8	41451107400	Pulsante accensione / On/Off button / Zündungstaste / Touche d'allumage / Botón encendido	43.00
9	41451200500	Scheda madre completa / Complete mother board / Komplette Hauptplatine / Carte mère complete / Tarjeta madre completa	170.00
9	41451200500B	Scheda madre non programmata / Unprogrammed motherboard / Unprogrammierte Hauptplatine / Carte mère non programmée / Tarjeta madre sin programa	168.00
10	41451202800	Morsettiera / Terminal board / Klemmenbret / Serre-câble / Borne	24.00
11	41450901600	Motoriduttore 3,3 rpm Merkle Korff / Reduction motor 3,3 rpm Merkle Korff / Getriebemotor 3,3 RPM MERKLE KORFF / Motorréducteur 3,3 RPM MERKLE KORFF / Motorreductor 3,3 rpm Merkle Korff	91.00
12	4120398	Connettore motoriduttore-coclea / Reduction motor-feed screw connector / Verbindung Getriebemotor-Schnecke / Connecteur motorréducteur-vis sans fin / Conector motorreductor-cóclea	21.00
13	41400944351	Base della coclea / Feed screw base / Untergestell der Förderschnecke / Base de la vis sans fin / Base de la cóclea	24.00
14	41400903310	Flangia condotto coclea / Base of feed screw conduit / Untergestell Rohrleitung der Förderschnecke / Base du conduit de la vis sans fin / Base de conducto de la cóclea	19.00
15	4120615	Guarnizione base della coclea / Feed screw base gasket / Dichtung Untergestell der Förderschnecke / Joint pour la base de la vis sans fin / Junta base de la cóclea	18.00
16	41200901040	Coclea di caricamento pellet / Pellet feed screw / Pelletsförderschnecke / Vis sans fin pour chargement du pellet / Cóclea de carga pellet	45.00
17	418008029	Guarnizione / Gasket / Dichtung / Joint / Junta	20.00
18	41401077540V	Condotto della coclea / Conduit of feed screw / Rohrleitung der Förderschnecke / Conduit de la vis sans fin / Conducto de la cóclea	80.00
19	41451201900	Cavo Flat L 1,4 M / Flat cable L 1,4 M / Flat Kable L 1,4 M / Câble Flat L 1,4 M / Cable Flat L 1,4 M	20.00
20	41451200600	Pannello comandi / Control panel / Bedienblende / Panneau de commande / Panel de mandos	102.00
21	41450901200	Sonda temperatura acqua / Water temperature sensor / Wassertemperaturfühler / Sonde température eau / Sonda temperatura agua	25.00
22	41451107300	Clickson 95°C / Clickson 95°C / Clickson 95°C / Clickson 95°C / Clickson 95°C	19.00
23	412007004	Clickson 110°C / Clickson 110°C / Clickson 110°C / Clickson 110°C / Clickson 110°C	19.00

COMPACT 14

Componenti interni idraulici SENZA kit acqua sanitaria / Internal plumbing components WITHOUT domestic water kit / Interne hydraulische Bauteile OHNE Brauchwassersatz / Composants hydrauliques internes SANS kit eau sanitaire / Componentes internos hidráulicos SIN kit de agua sanitaria

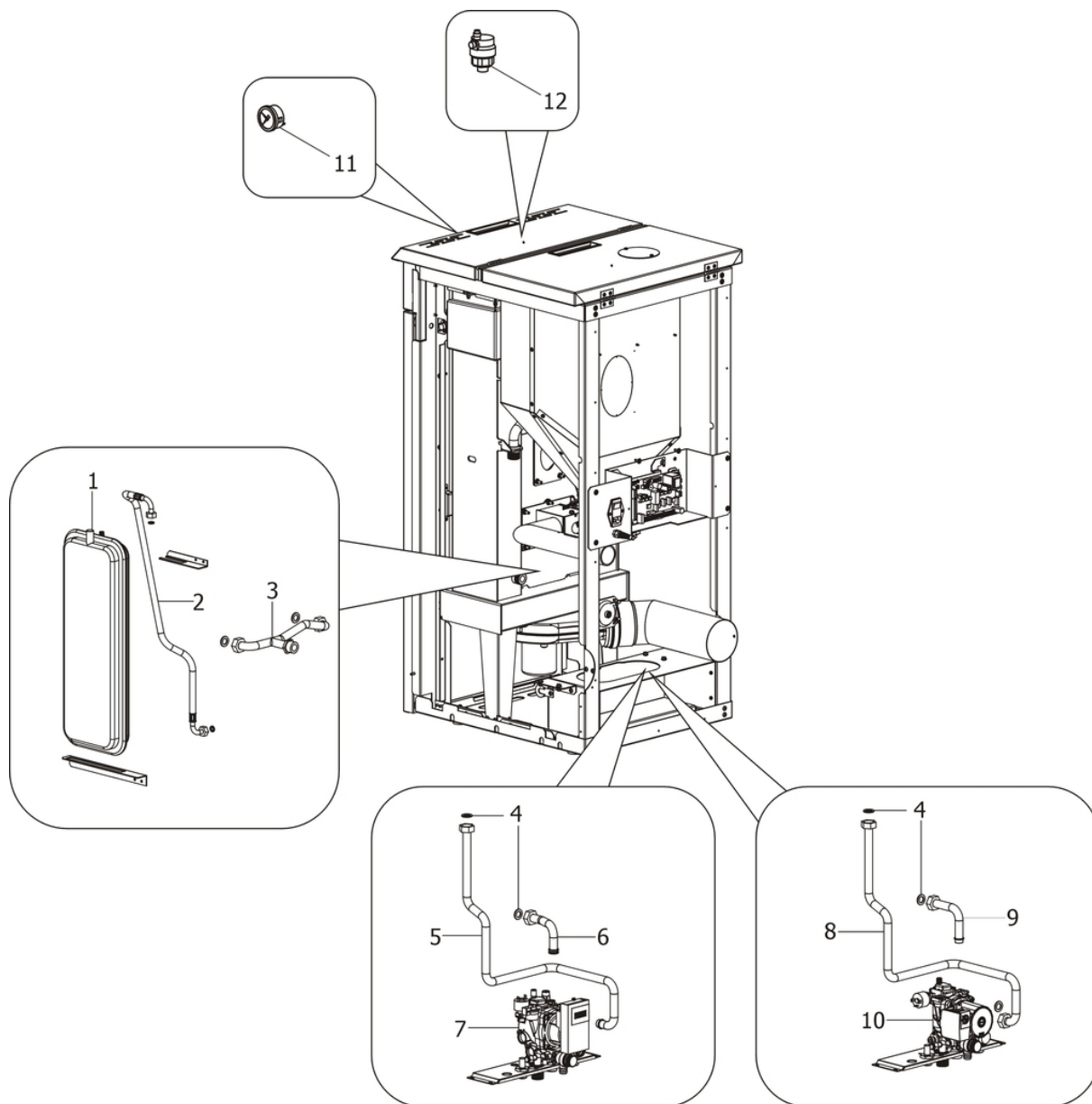

N°	Codice/Code	Descrizioni / Description / Beschreibung / Description / Descripción	Prezzo (€)
1	4120775	Vaso espansione (6 l) / Expansion vessel (6 l) / Expansionsgefäß (6 l) / Vase d'expansion (6 l) / Vaso de expansión (6 l)	72.00
2	41501100800	Tubo di mandata acqua da caldaia / Boiler water delivery tube / Vorlaufrohr Wasser vom Kessel / Tuyau de refoulement eau de la chaudière / Tubo de envío de agua de la caldera	29.00
3	41501302000	Tubo di ritorno acqua in caldaia / Boiler water return tube / Rücklaufrohr Wasser zum Kessel / Tuyau retour eau dans la chaudière / Tubo de regreso de agua a la caldera	47.00
4	41207910	Kit guarnizioni impianto idraulico / Hydraulic system gasket kit / Dichtungsbausatz für Hydraulikanlage / Kit de joints pour l'installation hydraulique / Kit de juntas de la instalación de fontanería	25.00
4	41207910	Kit guarnizioni impianto idraulico / Hydraulic system gasket kit / Dichtungsbausatz für Hydraulikanlage / Kit de joints pour l'installation hydraulique / Kit de juntas de la instalación de fontanería	25.00
5	41501302200	Tubo di mandata impianto / Water delivery tube / Wasser Vorlaufrohr / Tuyau de refoulement eau / Tubo de envío de agua	66.00
6	41501302100	Tubo di ritorno acqua / Water return tube / Wasserrücklaufrohr / Tuyau retour eau / Tubo de regreso agua	26.00

7	41501101701	Gruppo idraulico - solo riscaldamento / Hydraulic unit - heating only / Hydraulikeinheit - nur Heizung / Unité hydraulique - seul chauffage / Unidad hidráulica - solo calentamiento	-
8	41501302400	Tubo di mandata per circolatore AE / Water delivery tube for HE circulator / Vorlaufrohr Wasser für HE Pumpe / Tuyau de refoulement pour le pompe de circulation AE / Tubo de envío de agua por la bomba AE	63.00
9	41501302300	Tubo ritorno per circolatore AE / Water return tube for AE pump / Verbindungsrücklaufrohr für HE Pumpe / Tuyau de connection retour pour la pompe de circulation / Tubo de conexión regreso por la bomba	27.00
10	41501202701	Gruppo idraulico - solo riscaldamento - con circolatore alta efficienza / Hydraulic unit - heating only - with high efficiency circulation pump / Hydraulikeinheit - nur Heizung - mit Hochleistungs-Zirkulator / Unité hydraulique - seul chauffage - avec circulateur à haut rendement / Unidad hidráulica - solo calentamiento - con bomba alto rendimiento	369.00
11	41501100901	Manometro / Manometer / Manometer / Manomètre / Manómetro	40.00
12	4120779	Valvola di sfiato / Vent valve / Entlüftungsventil / Soupape de dégagement / Válvula respiradero	25.00

COMPACT 14

Gruppo scambiatore / Exchanger group / Austausch Baugruppe / Groupe échangeur / Grupo intercambiador

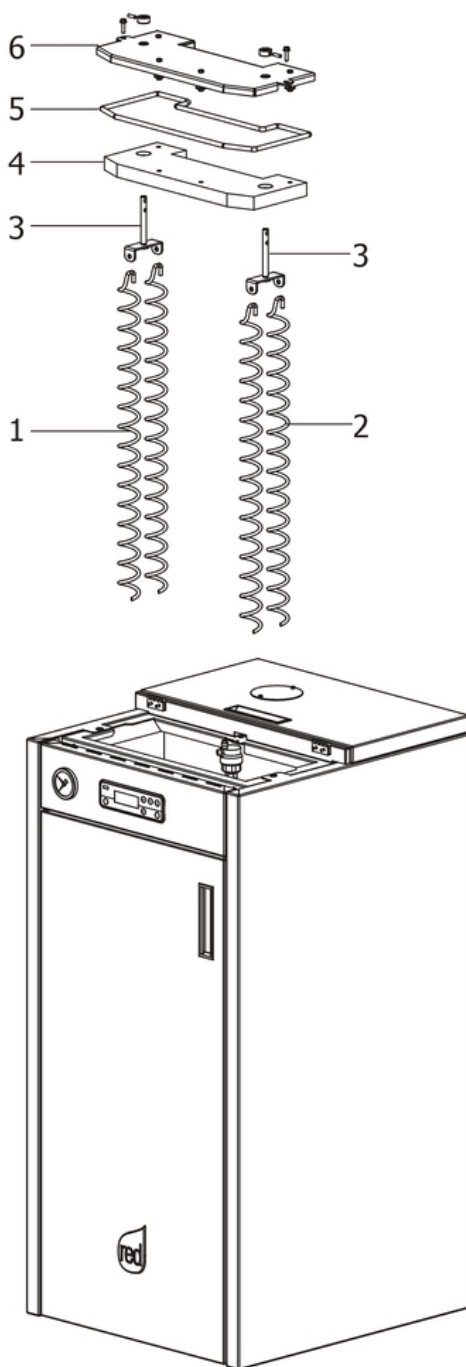

N°	Codice/Code	Descrizioni / Description / Beschreibung / Description / Descripción	Prezzo (€)
1	41201400800	Eliche raschiatore Inox (1 pz.) prive di barra ondulata interna / Inox turbulator props (1 pc.) without the wawed inner part / Propeller des Schabers Inox (1 Teil) ohne die innern gewellten Teile / Hélices turbulateur Inox (1 pz.) sans la partie ondulée interne / Héliche rascador Inox (1 pz.) sin la parte ondulada interna	41.00
2	41201400800	Eliche raschiatore Inox (1 pz.) prive di barra ondulata interna / Inox turbulator props (1 pc.) without the wawed inner part / Propeller des Schabers Inox (1 Teil) ohne die innern gewellten Teile / Hélices turbulateur Inox (1 pz.) sans la partie ondulée interne / Héliche rascador Inox (1 pz.) sin la parte ondulada interna	41.00

3	41400914740	Staffa sostegno raschiatore / Turbulator support bar / Haltebügel der Reinigungsspirale / étrier support turbulateur / Zuncho apoyo rascador	23.00
4	41150900100	Pannello calorite coperchio caldaia / Boiler cover calorite panel / Kesseldeckepaneel aus Calorite / Panneau en calorite couvercle chaudière / Panel en calorite tapa caldera	28.00
5	4120103A	Cordino fibroceramico Ø 10 mm (5 mt.) / Ceramic fibre cord Ø 10 mm (5 m) / Keramikfaserschnur Ø 10 mm (5 m) / Cordon en fibre céramique Ø 10 mm (5 m) / Junta a cuerda de fibra cerámica Ø 10 mm (5 m)	28.00
5	4120103B	Cordino fibroceramico Ø 10 mm (50 mt.) / Ceramic fibre cord Ø 10 mm (50 m) / Keramikfaserschnur Ø 10 mm (50 m) / Cordon en fibre céramique Ø 10 mm (50 m) / Junta a cuerda de fibra cerámica Ø 10 mm (50 m)	163.00
6	41400914840V	Coperchio scambiatore / Exchanger cover / Deckel des Austauschers / Couvercle Echangeur / Tapa intercambiador	52.00