

COMPACT 45 EASY CLEAN

Componenti Struttura Esterna / External structure components / Bauteile Aussenkorpus / Composants structure externe / Componentes estructura externa

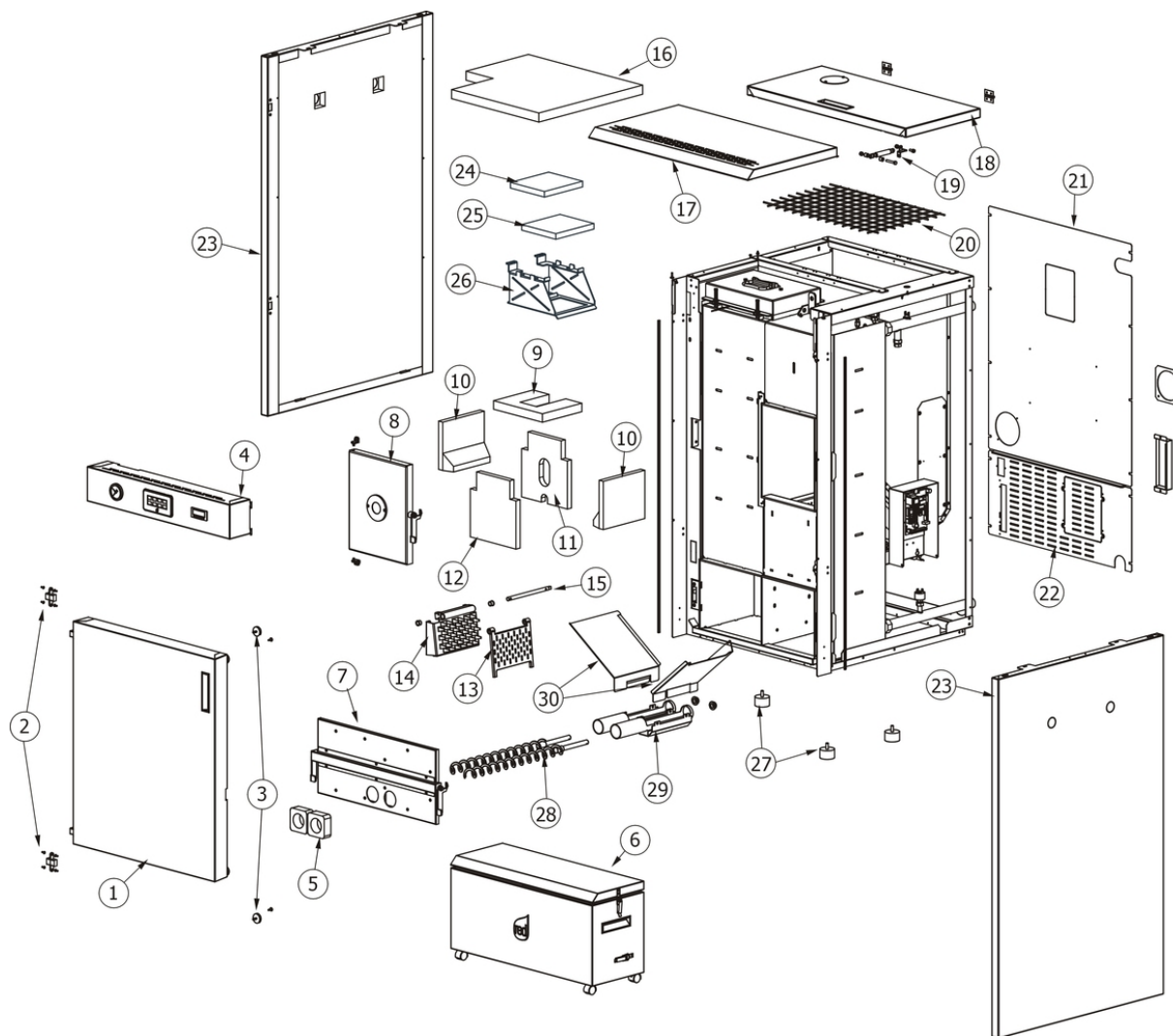

N°	Codice/Code	Descrizioni / Description / Beschreibung / Description / Descripcion	Prezzo (€)
1	41401435350	Porta esterna completa / Complete external door / Komplette Außentür / Porte extérieure complète / Puerta exterior completa	193.00
2	41201501700	Cerniera Pz.2 / Hinge Pcs.2 / Scharnier Stk.2 / Charnière Pcs.2 / Bisagra Pz.2	37.00
3	41801001500	Magnete / Magnet / Magnet / Aimant / Imán	38.00
4	41401435261	Supporto pannello comandi / Display stand / Fassung für Bedienblende / Support panneau des commandes / Soporte panel de mandos	47.00
5	41801401001	Guarnizione / Gasket / Dichtung / Joint / Junta	16.00
6	41401435650	Cassetto cenere / Ash drawer / Aschenkasten / Tiroir à cendres / Cajón ceniza	366.00
6	41801401100	Ruota ø30 trolley (pz.4) / Wheel ø30 trolley (Pcs.4) / Räder ø30 trolley (Stk.4) / Roue ø30 trolley (Pcs.4) / Rueda ø30 trolley (Pz.4)	25.00
7	41401433950	Cassetto cenere / Ash drawer / Aschenkasten / Tiroir à cendres / Cajón ceniza	190.00
8	41401415950	Porta fuoco completa in ghisa / Cast iron complete fire door / Komplette Feuertür aus Guß / Porte foyer complète en fonte / Puerta hogar completa de arrabio	163.00
9	41151400501	Deflettore in vermiculite / Vermiculite deflector / Leitblech aus Vermiculite / Déflecteur en vermiculite / Deflector en vermiculite	32.00
10	41151400200	Vermiculite laterale / Lateral Vermiculite / Seitliches Vermiculite / Vermiculite latéral / Vermiculite lateral	38.00
10	41151400200	Vermiculite laterale / Lateral Vermiculite / Seitliches Vermiculite / Vermiculite latéral / Vermiculite lateral	38.00
11	41151400301	Vermiculite posteriore / Rear Vermiculite / Hinteres Vermiculite / Vermiculite postérieur / Vermiculite posterior	55.00

12	41151400400	Vermiculite anteriore / Frontal Vermiculite / Vorderes Vermiculite / Vercimulite antérieur / Vermiculite frontal	32.00
13	41301200460	Griglia rotante / Rotating grille / Drehende Gitter / Grille tournate / Rejilla voltante	56.00
14	41401414040V	Pettine per griglia / Comb for grille / Kamm für Gitter / Peigne pour grille / Peine para rejilla	147.00
15	41201401000	Perno rotazione griglia / Pivot for grille revolution / Bolzen für Drehung der Gitter / Pivot rotation grille / Perno rotación rejilla	140.00
16	41151402200	Pannello isolante / Insulating panel / Isolierplatte / Panneau isolant / Panel aislante	123.00
17	41401417050	Coperchio anteriore / Frontal cover / Vorderes Deckel / Couvercle antérieur / Tapadera frontal	73.00
18	41401416750	Coperchio serbatoio pellet / Pellet hopper cover / Deckel Pelletbehälter / Couvercle réservoir pellet / Tapadera depósito	89.00
19	41801101400	Pistone a gas / Gas-piston / Gas-Kolben / Piston à gaz / Pistón a gas	44.00
20	41401437360	Griglia antintrusione / Hopper protection grille / Schutzgitter Pelletbehälter / Grille de protection réservoir / Rejilla de protección depósito	33.00
21	41401412330	Schiena posteriore superiore / Upper rear back / Hintere oberes Rückwand / Dosseret postérieur supérieur / Parte trasera superior	45.00
22	41401412430	Schiena posteriore inferiore / Lower rear back / Hintere unteres Rückwand / Dosseret postérieur inférieur / Parte trasera inferior	41.00
23	41401416550	Fianco DX/SX / R./L. Side / R./L. Seite / Côté D./G. / Lado DCHO/IZDO	127.00
23	41401416550	Fianco DX/SX / R./L. Side / R./L. Seite / Côté D./G. / Lado DCHO/IZDO	127.00
24	41151400600	Deflettore in vermiculite / Vermiculite deflector / Leitblech aus Vermiculite / Déflecteur en vermiculite / Deflector en vermiculite	20.00
25	41151400600	Deflettore in vermiculite / Vermiculite deflector / Leitblech aus Vermiculite / Déflecteur en vermiculite / Deflector en vermiculite	20.00
26	41401411430	Supporto deflettore / Deflector support / Blechhalterung / Support déflecteur / Soporte deflector	72.00
27	41801400200	Piedini di appoggio (4 pz.) / Support feet (4 pcs.) / Einstellfüße (4 Stck.) / Vérins d'appui (4 p.es) / Pies de apoyo (4 piezas)	35.00
28	41401434300	Coclea cenere / Ash screw / Aschenschnecke / Vis-sans-fin cendre / Cóclea ceniza	48.00
29	41601401840V	Tubo cenere / Ash tube / Aschenrohr / Tuyau cendre / Tubo ceniza	47.00
30	41401413830	Scivolo cenere SX / L. Ash ramp / L. Aschenrutsche / Glissèrie cendre G. / Tobogán ceniza IZDO	24.00
30	41401433831	Scivolo cenere DX / R. Ash ramp / R. Aschenrutsche / Glissèrie cendre D. / Tobogán ceniza DCHO	23.00

COMPACT 45 EASY CLEAN

Porta fuoco / Fire door / Feuertür / Porte foyer / Puerta hogar

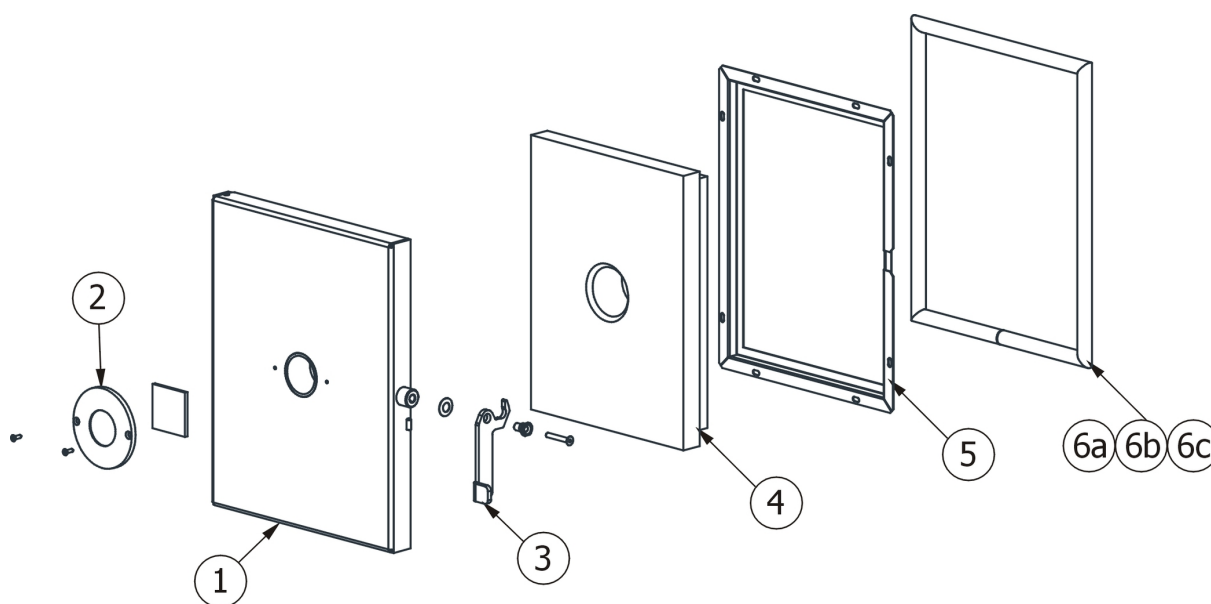

N°	Codice/Code	Descrizioni / Description / Beschreibung / Description / Descripción	Prezzo (€)
1	41401416040V	Telaio porta fuoco in ghisa / Cast iron fire door frame / Feuertürrahment aus Guß / Cadre porte foyer en fonte / Armazón puerta hogar de arrabio	74.00
2	41201302800V	Spioncino con vetro - Spioncino Ø 40 / Peephole with glass - Peephole Ø 40 / Guckloch mit Scheibe - Guckloch Ø 40 / Judas avec vitre - Judas Ø 40 / Mirilla con cristal - Mirilla Ø 40	36.00
3	41401133230V	Maniglia / Handle / Griff / Poignée / Tirador	21.00
4	41151400800	Vermiculite / Vermiculite / Vermiculite / Vermiculite / Vermiculite	82.00
5	41401416330	Telaio interno porta fuoco / Internal fire door frame / Innere Feuertürrahmen / Cadre interne porte foyer / Armazón interior puerta hogar	25.00
6a	41201406800	Kit guarnizione Ø 16 - 4 m + silicone / Kit gasket Ø 16 - 4 m + silicon / Bausatz Dichtung Ø 16 - 4 m + Silikon / Kit Joint Ø 16 - 4 m + silicon / Kit junta Ø 16 - 4 m + silicón	66.00
6b	41201406800A	Guarnizione Ø 16 - 5 m / Gasket Ø 16 - 5 m / Dichtung Ø 16 - 5 m / Joint Ø 16 - 5 m / Junta Ø 16 - 5 m	45.00
6c	41201406800B	Guarnizione Ø 16 - 50 m / Gasket Ø 16 - 50 m / Dichtung Ø 16 - 50 m / Joint Ø 16 - 50 m / Junta Ø 16 - 50 m	220.00

COMPACT 45 EASY CLEAN

Componenti interni meccanici ed elettronici / Electronic and mechanic internal parts / Interne mechanische und elektronische Bauteile / Composants internes mécaniques et électroniques / Componentes internos electrónicos y mecánicos

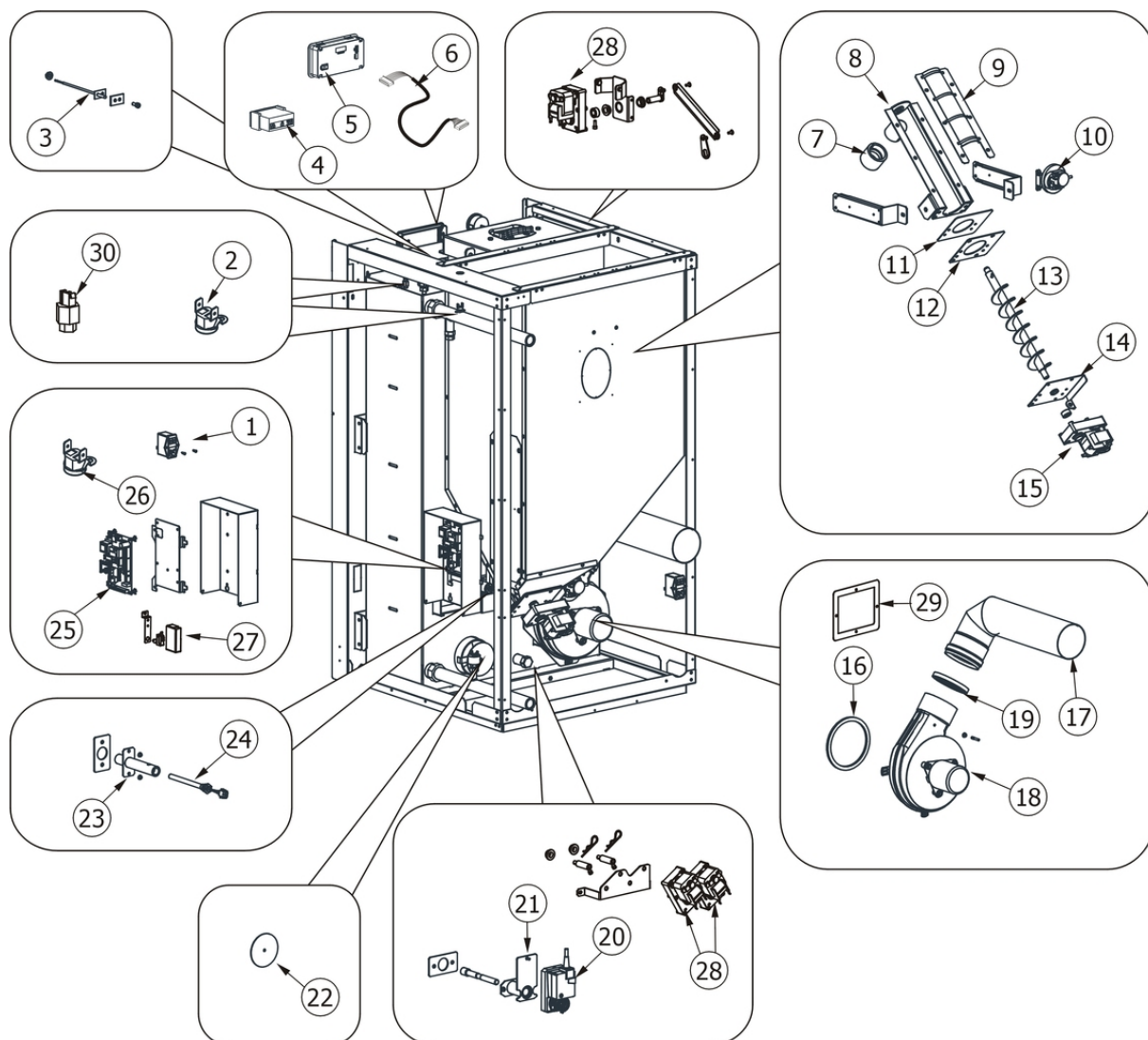

N°	Codice/Code	Descrizioni / Description / Beschreibung / Description / Descripción	Prezzo (€)
1	41451107400	Pulsante accensione / On/Off button / Zündungstaste / Touche d'allumage / Botón encendido	43.00
2	41451107300	Clickson 95°C / Clickson 95°C / Clickson 95°C / Clickson 95°C / Clickson 95°C	19.00
3	41451402000	Sonda fumi con flangia / Smoke sensor with flange / Rauchsonde mit Flansche / Sonde fumées avec bride / Sonda humos con brida	28.00
4	41451403100	Timer digitale / Digital timer / Digital timer / Minuteur digital / Temporizador digital	100.00
5	41451400670B	Pannello comandi / Control panel / Bedienblende / Panneau de commandes / Panel de mandos	167.00
6	41451403001	Cablaggio pannello comandi / Display wiring / Bedienblende Verkabelung / Câblage panneau de commandes / Cableado panel de mandos	26.00
7	41201200801	Raccordo in gomma / Silicon Joint / Muffe aus Gummi / Junction en silicone / Junta en silicona	21.00
8	41401414640V	Condotto della coclea / Feed screw conduit / Rohrleitung der Förderschnecke / Conduit de la vis sans fin / Conducto de la cóclea	57.00
9	41401307530	Coperchio coclea / Feed screw cover / Deckel der Rohrleitung / Couvercle de la vis sans fin / Tapa de la cóclea	23.00
10	414508040	Pressostato 1.2 mbar / Pressure switch 1.2 mbar / Druckwächter 1.2 mbar / Pressostat 1.2 mbar / Presostato 1.2 mbar	38.00
11	41400903310	Flangia condotto coclea / Base of feed screw conduit / Untergestell Rohrleitung der Förderschnecke / Base du conduit de la vis sans fin / Base de conducto de la cóclea	19.00

12	4120615	Guarnizione base della coclea / Feed screw base gasket / Dichtung Untergestell der Förderschnecke / Joint pour la base de la vis sans fin / Junta base de la cóclea	18.00
13	41201300240	Coclea di caricamento pellet / Pellet feed screw / Pelletsförderschnecke / Vis sans fin pour chargement du pellet / Cóclea de carga pellet	60.00
14	41400944351	Base della coclea / Feed screw base / Untergestell der Förderschnecke / Base de la vis sans fin / Base de la cóclea	24.00
15	41451205100	Motoriduttore 5,6 rpm Merkle Korff / Reduction motor 5,6 rpm Merkle Korff / Getriebemotor 5,6 rpm Merkle Korff / Motorréducteur 5,6 rpm Merkle Korff / Motorreductor 5,6 rpm Merkle Korff	127.00
16	41801100100	Guarnizione adesiva voluta fumi / Adhesive gasket smoke volute / Haftendichtung Rauchvolute / Joint adhesive volute fumées / Junta adhesiva voluta humos	20.00
17	41601103960	Tubo uscita fumi / Smoke outlet pipe / Rohr Rauchabzug / Tuyau sortie fumées / Tubo salida humos	66.00
18	41451201750	Ventilatore fumi / Smoke exhaust fan / Rauchabsauggebläse / Ventilateur aspiration fumées / Ventilador aspiración de humos	224.00
19	40A12022	Guarnizione Ø 100 - 5 Pz / Gasket Ø 100 - 5 Pcs / Dichtung Ø 100 - 5 Stck / Joint Ø 100 - 5 Pcs / Junta Ø 100 - 5 Pzs	20.00
20	41451203300	Attuatore / Actuator / Trieb / Actionneur / Actuador	321.00
21	41401414340V	Supporto attuatore / Actuator support / Triebhalterung / Support actionneur / Soporte actuador	45.00
22	41401392240	Piattello registro aria / Adjustment plate for combustion air / Einstellsteller Verbrennungsluft / Bobèche registre aire / Arandela regulación aire de combustión	21.00
23	41401412640V	Condotto candelella / Sparkplug conduit / Zündkerzenkanal / Conduit bougie / Conducto bujía	41.00
24	41451401800	Candelella 350 Watt / Sparkplug 350 Watt / Zündkerze 350 Watt / Bougie 350 Watt / Bujía 350 Watt	44.00
24	41801599250	Kit 50 candelella 350 Watt / 50 Sparkplugs 350 Watt kit / Bausatz 50 Zündkerzen 350 Watt / Kit 50 Bougies 350 Watt / Kit 50 Bujías 350 Watt	1,764.00
25	41451104900	Scheda aggiuntiva hydro / Supplementary mother board Hydro / Zusätzliche Platine Hydro / Carte mère additionnelle Hydro / Tarjeta adicional Hydro	47.00
25	41451400600	Scheda madre vergine, senza software / Motherboard with no software / Hauptplatine ohne Software / Carte mère vierge, sans software / Tarjeta madre virgen, sin software	168.00
25	41451400600B	Scheda madre / Motherboard / Hauptplatine / Carte mère / Tarjeta madre	167.00
26	412007004	Clickson 110°C / Clickson 110°C / Clickson 110°C / Clickson 110°C / Clickson 110°C	19.00
27	4160457	Pulsante per l'interruzione dell'alimentazione elettrica / power supply on-off button / Taste zur Unterbrechung der Stromversorgung / Bouton d'arrêt de l'alimentation électrique / Botón de corte de la alimentación eléctrica	19.00
28	41450901600	Motoriduttore 3,3 rpm Merkle Korff / Reduction motor 3,3 rpm Merkle Korff / Getriebemotor 3,3 RPM MERKLE KORFF / Motorréducteur 3,3 RPM MERKLE KORFF / Motorreductor 3,3 rpm Merkle Korff	91.00
28	41450901600	Motoriduttore 3,3 rpm Merkle Korff / Reduction motor 3,3 rpm Merkle Korff / Getriebemotor 3,3 RPM MERKLE KORFF / Motorréducteur 3,3 RPM MERKLE KORFF / Motorreductor 3,3 rpm Merkle Korff	91.00
29	41401413920	Flangia ventilatore fumi / Smoke fan flange / Befestigungsflansche für Rauchgebläse / Bride ventilateur fumées / Brida fijación ventilador humos	24.00
29	41801400300	Guarnizione 158x158x3 mm / Gasket 158x158x3 mm / Dichtung 158x158x3 mm / Joint 158x158x3 mm / Junta 158x158x3 mm	16.00
30	41451402100	Sonda acqua / Water sensor / Wassersonde / Sonde eau / Sonda agua	23.00

COMPACT 45 EASY CLEAN

Componenti interni idraulici / Internal plumbing components / Interne hydraulische Bauteile / Composants hydrauliques internes / Componentes internos hidráulicos

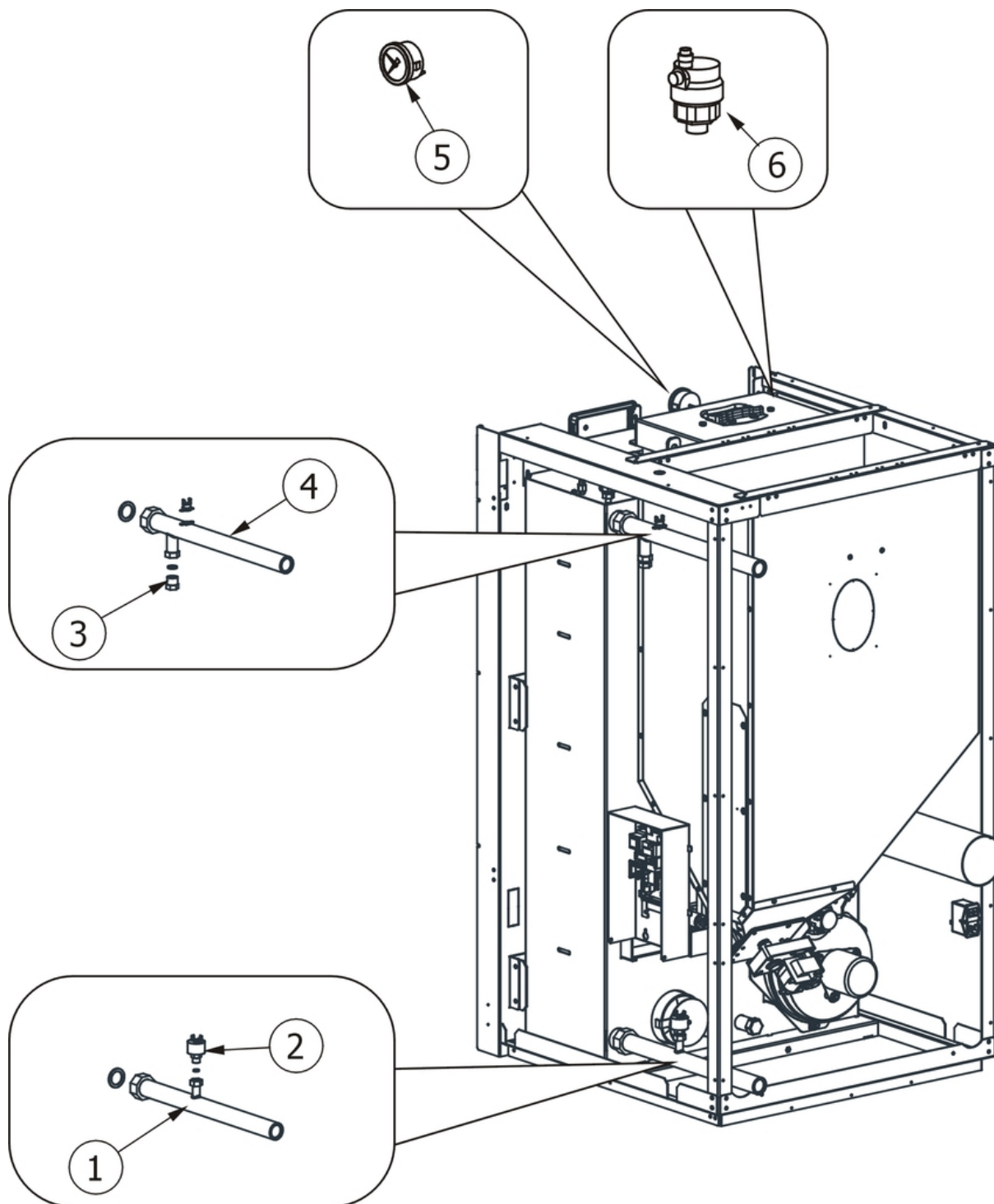

N°	Codice/Code	Descrizioni / Description / Beschreibung / Description / Descripción	Prezzo (€)
1	41501400560	Tubo ritorno / Return tube / Rücklaufrohr / Tuyau retour / Tubo de regreso	51.00
2	41451401700	Pressostato / Pressure switch / Druckwächter / Pressostat / Presostato	25.00
3	41501303700	Valvola di ritegno / Check valve / Kugelrückschlagventil / Vanne de retenue / Válvula de flujo simple	22.00
4	41501400660	Tubo mandata / Delivery tube / Vorlaufrohr / Tuyau refoulement / Tubo de envío	72.00
5	41501100901	Manometro / Manometer / Manometer / Manomètre / Manómetro	40.00

6	4120779	Valvola di sfiato / Vent valve / Entlüftungsventil / Soupape de dégagement / Válvula respiradero	25.00
---	---------	--	-------

COMPACT 45 EASY CLEAN

Gruppo scambiatore / Exchanger group / Austausch Baugruppe / Groupe échangeur / Grupo intercambiador

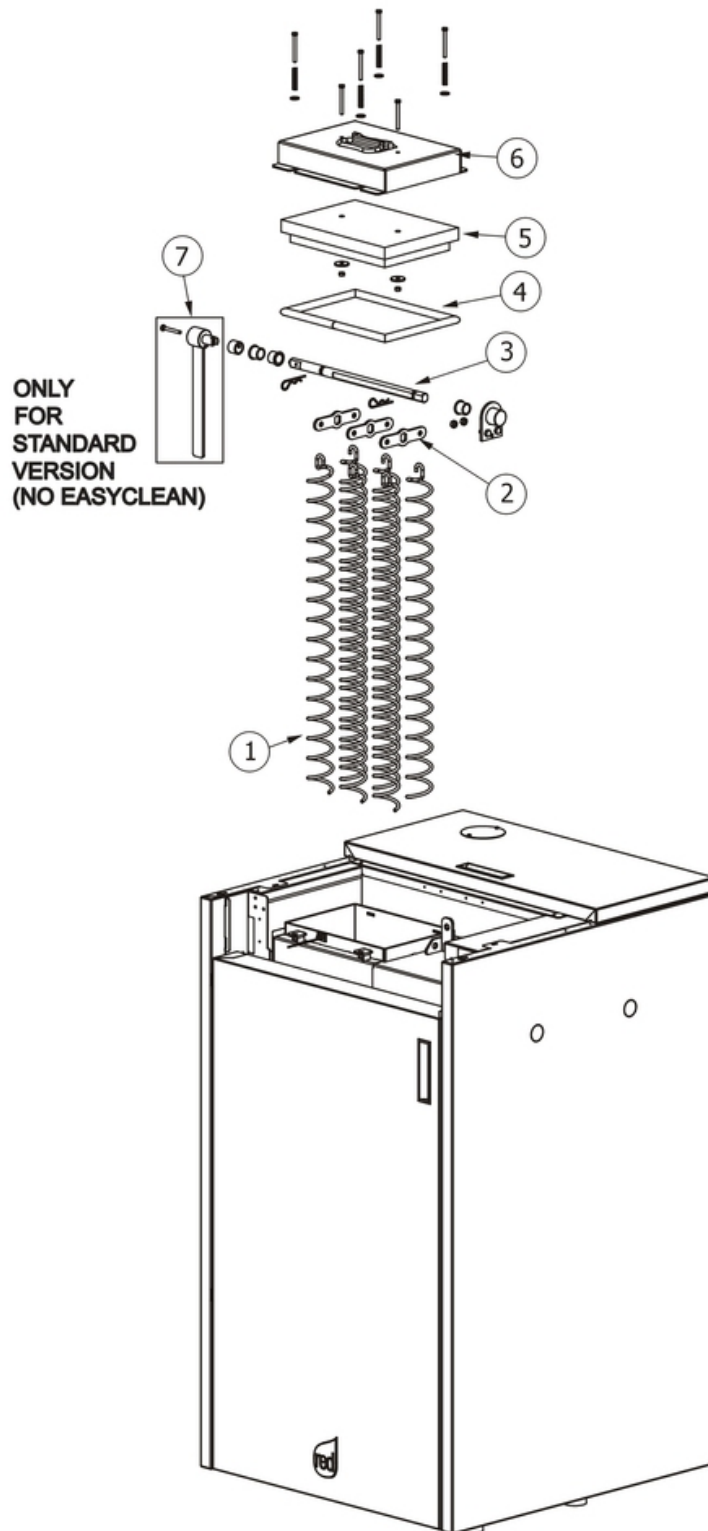

N°	Codice/Code	Descrizioni / Description / Beschreibung / Description / Descripción	Prezzo (€)
1	41201401400	Turbolatore Inox (1 pz.) / Inox turbolator (1 pc.) / Inox Turbolator (1 Teil) / Turboluteur Inox (1 pz.) / Rascador Inox (1 pz.)	53.00
2	41401415610	Biella turbolatori / Turbolator rod / Turbolator Pleuelstange / Bielle turbolateur / Biela rascador	18.00
3	41201401300	Asta turbolatori / Turbolator shaft / Turbolator Stange / Tige turbolateurs / Asta rascadores	48.00
4	41201406800	Kit guarnizione Ø 16 - 4 m + silicone / Kit gasket Ø 16 - 4 m + silicon / Bausatz Dichtung Ø 16 - 4 m + Silikon / Kit Joint Ø 16 - 4 m + silicon / Kit junta Ø 16 - 4 m + silicón	66.00
4	41201406800A	Guarnizione Ø 16 - 5 m / Gasket Ø 16 - 5 m / Dichtung Ø 16 - 5 m / Joint Ø 16 - 5 m / Junta Ø 16 - 5 m	45.00
4	41201406800B	Guarnizione Ø 16 - 50 m / Gasket Ø 16 - 50 m / Dichtung Ø 16 - 50 m / Joint Ø 16 - 50 m / Junta Ø 16 - 50 m	220.00
5	41151400700	Pannello in Vermiculite / Vermiculite panel / Platte aus Vermiculite / Panneau en Vermiculite / Panel de Vermiculite	58.00
6	41401415740V	Coperchio turbolatori / Turbolators cover / Turbolatorsdeckel / Couverture turbolateurs / Tapa de los rascadores	51.00
7	41401315550	Leva manuale / Hand lever / Handhebel / Levier à main / Palanca manual	101.00