

# MCZ GROUP

## MUSA AIR

Componenti Struttura Esterna / External structure components / Bauteile Aussenkorpus / Composants structure externe / Componentes estructura externa

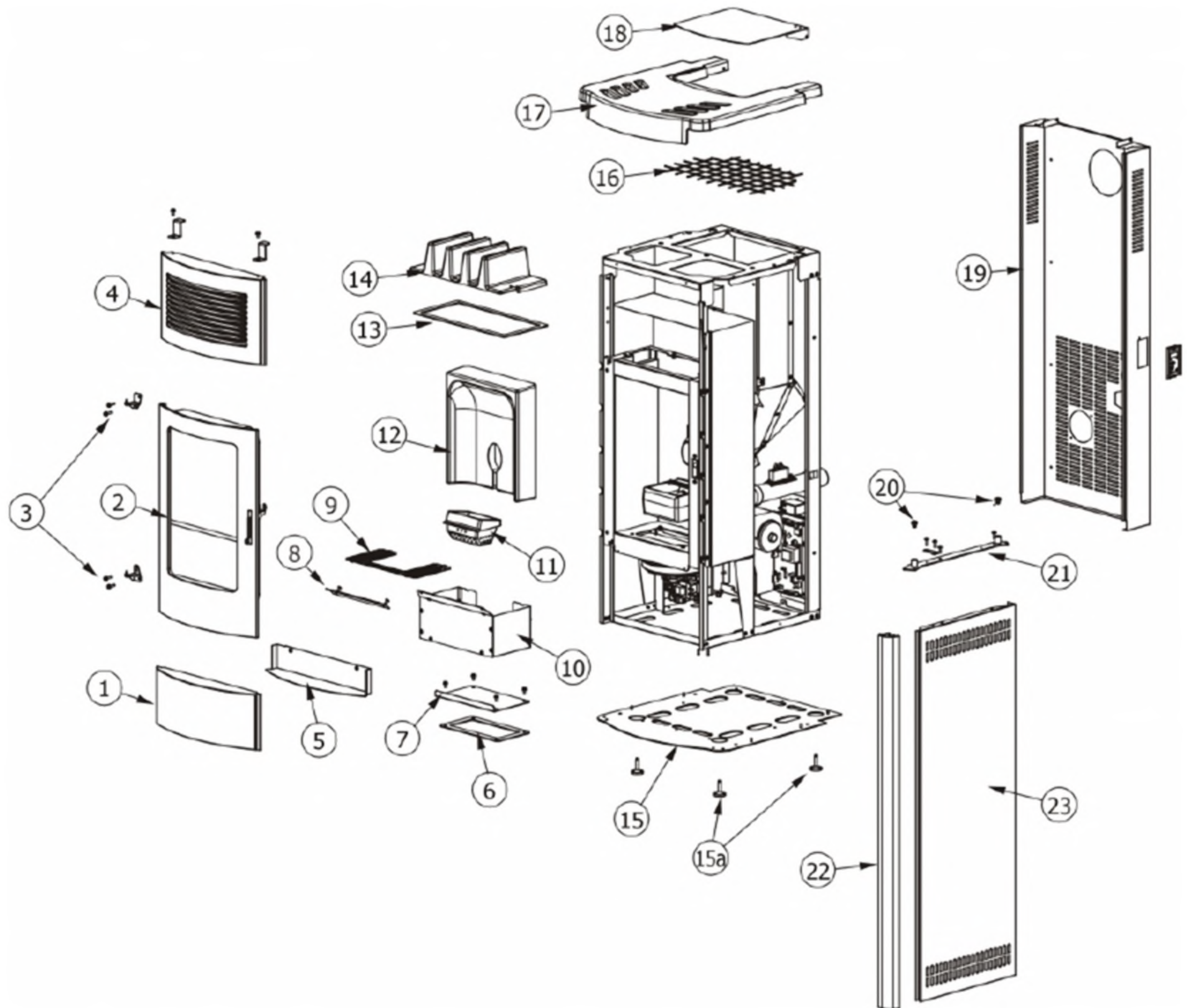

## MUSA AIR

Componenti Struttura Esterna / External structure components / Bauteile Aussenkorpus / Composants structure externe / Componentes estructura externa

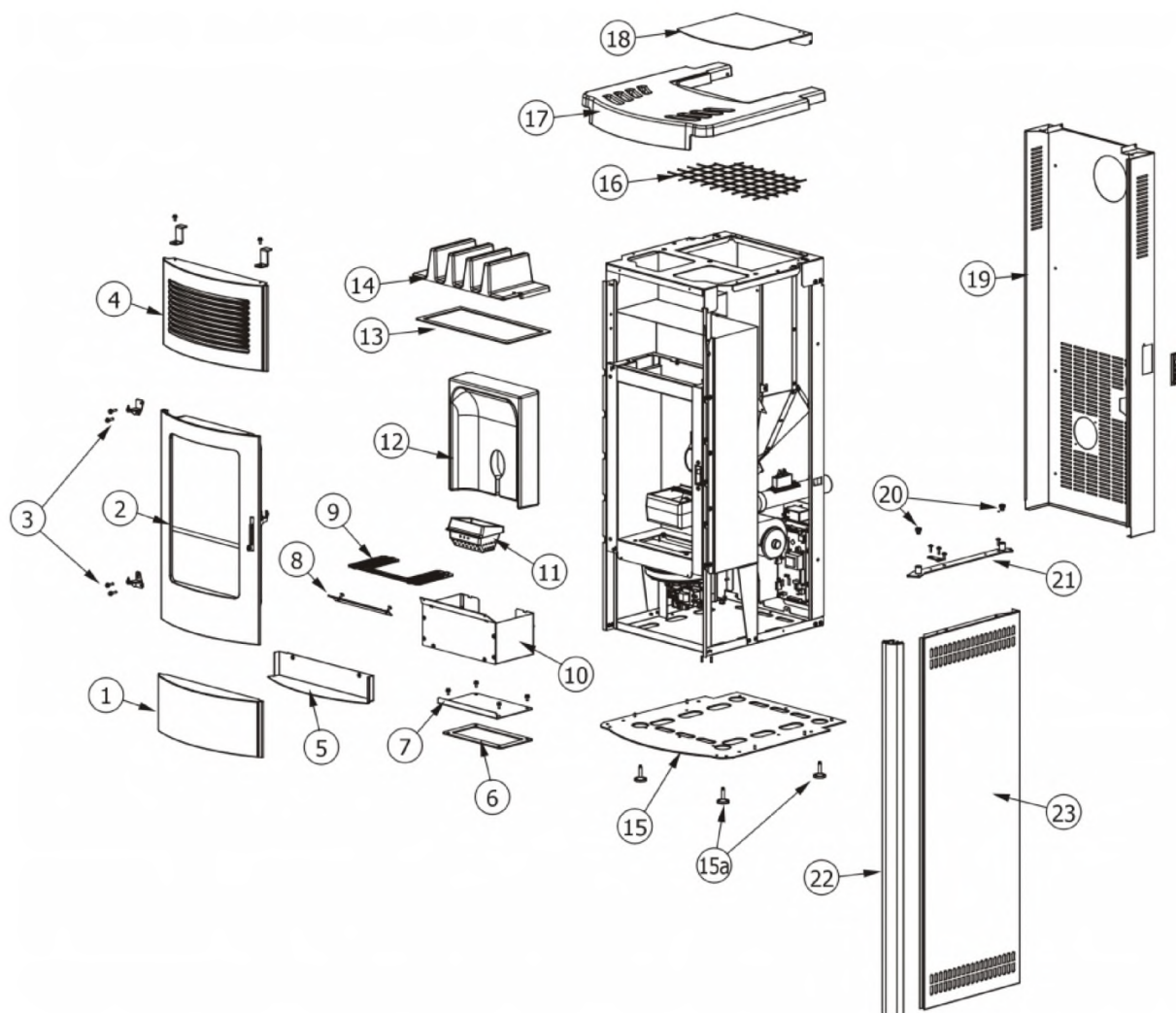

N°	Codice/Code	Descrizioni / Description / Beschreibung / Description / Descripción	Prezzo (€)
1	41300901000V	Tamponazione inferiore / Lower filler / Untere Stopfung / Plaque inférieure / Tapa inferior	72.00
2	41300801550	Porta finita completa / Complete finished door / Komplette Tür / Porte finie complète / Puerta completa	406.00
3	41200904061	Cerniera superiore e inferiore (2 pz) / Upper and lower hinge (2 pcs) / Oberes und unteres Scharnier (2 Stck) / Charnière supérieure et inférieure (2 pcs) / Bisagra superior e inferior (2 pz)	37.00
4	413008016V	Griglia uscita aria in ghisa / cast iron Air outlet grille / Gusseisernes Gitter Warmluftaustritt / Grille de sortie air chaud en fonte / Rejilla salida aire de arrabio	130.00
5	41400908230V	Riparo sotto la porta fuoco / Door protection / Schutz unter der Tür / Protection sous porte / Resguardo abajo puerta	30.00
6	418008025	Guarnizione / Gasket / Dichtung / Joint / Junta	22.00
6	4180080251	Kit 50 guarnizioni / Kit 50 gaskets / Bausatz 50 Dichtungen / Kit 50 joints / Kit 50 juntas	880.00
7	41400906330V	Tappo ispezione vano fumi / Smoke compartment inspection plug / Inspektionsdeckel Rauchabzug / Clapet inspection compartiment fumées / Tapón inspección compartimento humos	25.00
8	41400907830V	Deflettore cenere / Deflector / Aschenleitblech / Déflecteur / Deflector	25.00
9	41400906610V	Griglia focolare / Fire box grille / Feuerstellenrost / Grille foyer / Rejilla hogar	28.00
10	41400958130V	Cassetto cenere / Ash drawer / Aschenkasten / Tiroir à cendres / Cajón ceniza	80.00
11	413008003	Braciere completo in ghisa / Cast iron complete grate / Kompletter Brennertopf aus Gusseisen / Brasero complet en fonte / Brasero completo de arrabio	50.00
12	43650151	Schiena in Alutec® / Alutec® back / Rückwand aus Alutec® / Fond en Alutec® / Parte trasera en Alutec®	59.00
13	41800802600	Kit 50 guarnizioni / Kit 50 gaskets / Bausatz 50 Dichtungen / Kit 50 joints / Kit 50 juntas	760.00

<b>13</b>	<b>41800802601</b>	Guarnizione / Gasket / Dichtung / Joint / Junta	<b>19.00</b>
<b>14</b>	<b>413008001</b>	Scambiatore in ghisa / Cast iron exchanger / Gusseiserne Wärmetauscher / Echangeur en fonte / Intercambiador en arrabio	<b>111.00</b>
<b>15</b>	<b>41400909740V</b>	Basamento / Base / Basis / Base / Base	<b>86.00</b>
<b>15a</b>	<b>4120618</b>	Piedini di appoggio (4 pz) / Support feet (4 pcs) / Einstellfüße (4 Stck) / Vérins d'appui (4 pcs) / Pies de apoyo (4 pz)	<b>20.00</b>
<b>16</b>	<b>41400904100</b>	Griglia protezione serbatoio / Hopper protection grille / Schutzgitter Pelletbehälter / Grille de protection réservoir / Rejilla de protección depósito	<b>27.00</b>
<b>17</b>	<b>41300900900V</b>	Top grigio in ghisa / gray cast iron Top / Top Grauguss / Dessus fonte grise / Top gris de arrabio	<b>169.00</b>
<b>18</b>	<b>41400910160</b>	Coperchio serbatoio pellet / Pellet hopper cover / Deckel Pelletbehälter / Couvercle réservoir pellet / Tapadera depósito pellet	<b>53.00</b>
<b>19</b>	<b>41400910061</b>	Schiena esterna in acciaio / External back in steel / Aussenrückwand aus Stahl / Fond extérieur en acier / Panel trasero externo de acero	<b>83.00</b>
<b>20</b>	<b>4120180</b>	Gommini paracolpi (4 pz) / Rubber bumpers (4 pcs.) / Schlagschutzgummi (4 Stck) / Pièces caoutchouc antichoc (4 pcs) / Cauchitos anti-golpes (4 pz)	<b>21.00</b>
<b>21</b>	<b>41400910240V</b>	Staffa bloccaggio SX / L. Superior Bracket / Oberer LI. Bügel / Étrier supérieur G. / Abrazadera superior IZDO	<b>43.00</b>
<b>21</b>	<b>41400910340V</b>	Staffa bloccaggio DX / R. Superior Bracket / Oberer RE. Bügel / Étrier supérieur D. / Abrazadera superior DCHO	<b>44.00</b>
<b>22</b>	<b>41200804950</b>	Montante anteriore / Frontal vertical rod / Vordere Montageleiste / Montant antérieur / Montante anterior	<b>50.00</b>
<b>23</b>	<b>6909016</b>	Rivestimento completo White metal / Complete White metal cladding / Komplette Verkleidung White metal / Habillage complète White metal / Revestimiento completo White metal	<b>0.00</b>
<b>23</b>	<b>6909017</b>	Rivestimento completo Dark metal / Complete Dark metal cladding / Komplette Verkleidung Dark metal / Habillage complète Dark metal / Revestimiento completo Dark metal	<b>0.00</b>
<b>23</b>	<b>6909018</b>	Rivestimento completo Silver metal / Complete Silver metal cladding / Komplette Verkleidung Silver metal / Habillage complète Silver metal / Revestimiento completo Silver metal	<b>0.00</b>
<b>23</b>	<b>6909019</b>	Rivestimento completo Bordeaux metal / Complete Bordeaux metal cladding / Komplette Verkleidung Bordeaux metal / Habillage complète Bordeaux metal / Revestimiento completo Bordeaux metal	<b>0.00</b>

# MCZ GROUP

## MUSA AIR

Porta fuoco / Fire door / Feuertür / Porte foyer / Puerta hogar

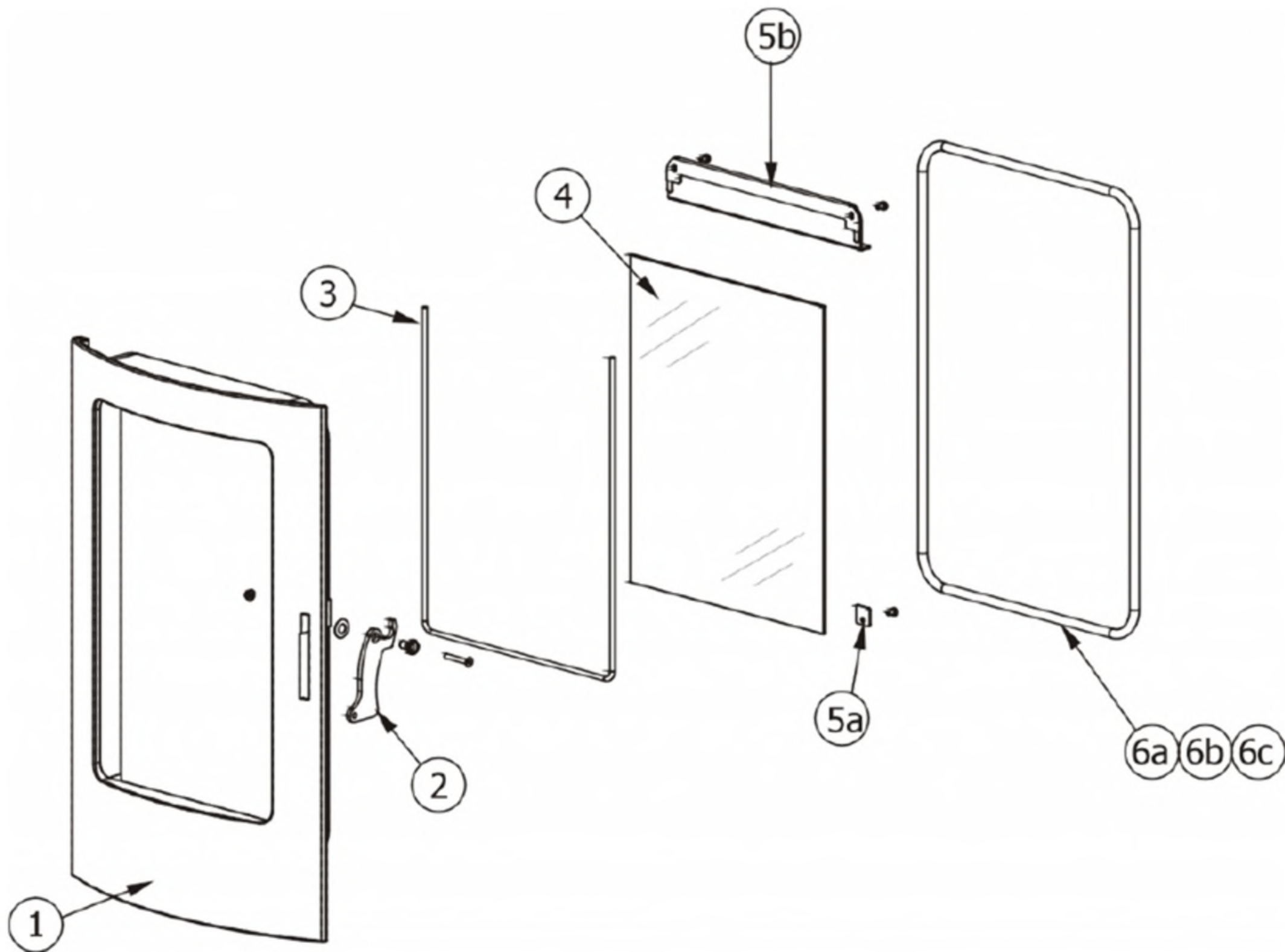

## MUSA AIR

Porta fuoco / Fire door / Feuertür / Porte foyer / Puerta hogar

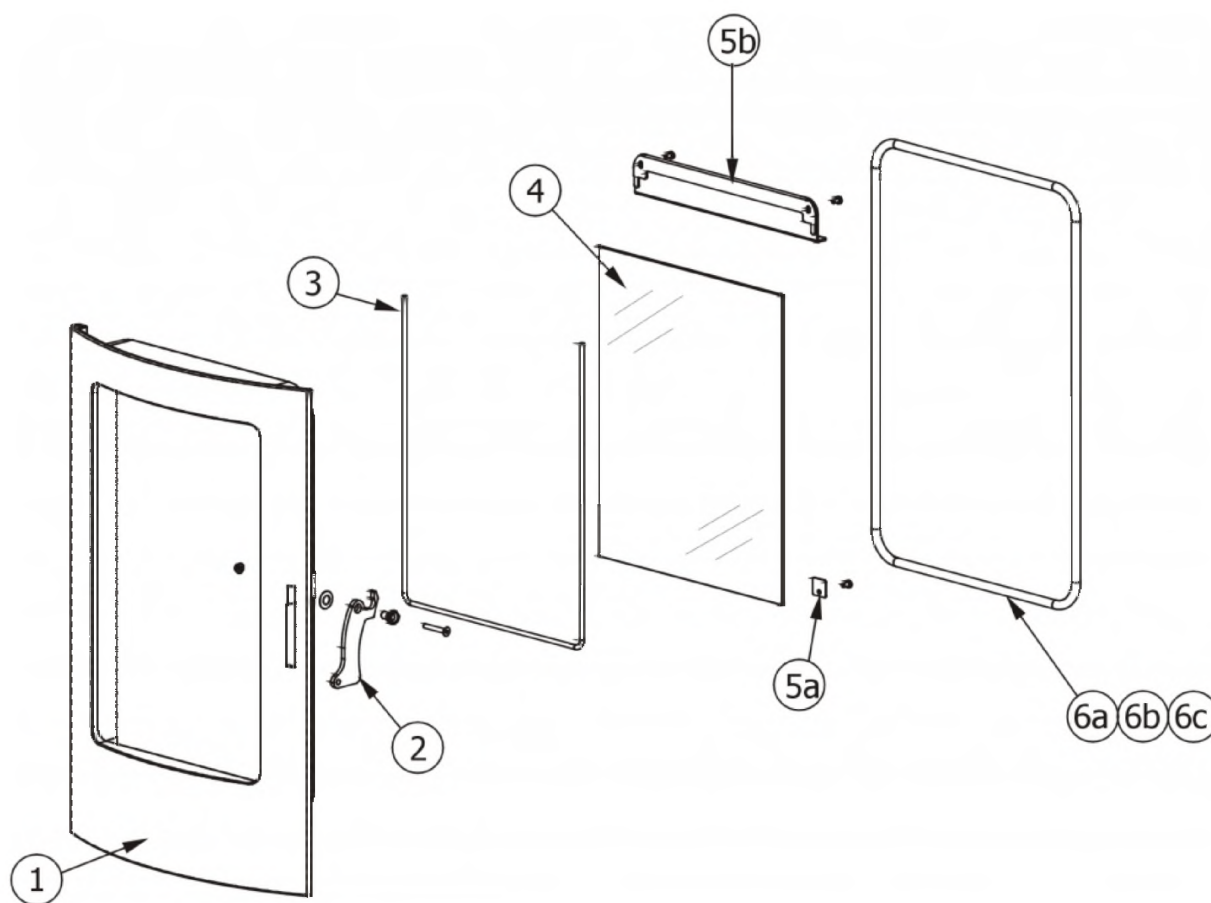

N°	Codice/Code	Descrizioni / Description / Beschreibung / Description / Descripción	Prezzo (€)
1	413008015V	Telaio porta fuoco / Fire door frame / Feuertürrahmen / Cadre porte foyer / Armazón puerta de arrabio	201.00
2	41400908660	Maniglia completa / Complete handle / Kompletter Griff / Poignée complète / Tirador completo	26.00
3	4120106	Guarnizione a nastro fireglass / Fireglass tape gasket / Banddichtung Fireglass / Joint ruban Fireglass / Guarnición a cinta Fireglass	28.00
4	41700900660	Vetroceramico con guarnizione / Glass with gasket / Glaskeramikscheibe mit Dichtung / Vitrocéramique avec joint / Cristal cerámico con guarnición	132.00
5a	41401077430	Staffe di fissaggio vetroceramico (4 pz.) / Pyroceram fastening brackets (4 pcs.) / Befestigungsbügel Glaskeramik (4 Stck.) / Étrier de fixation vitrocéramique (4 pz.) / Abrazaderas de fijación vidrio cerámico (4 piezas)	21.00
5b	41400908530V	Deflettore porta / Door deflector / Tür Leitblech / Déflecteur de la porte / Deflector de la puerta	26.00
6a	4120103A	Cordino fibrocaramico Ø 10 mm (5 mt.) / Ceramic fibre cord Ø 10 mm (5 m) / Keramikfaserschnur Ø 10 mm (5 m) / Cordon en fibre céramique Ø 10 mm (5 m) / Junta a cuerda de fibra cerámica Ø 10 mm (5 m)	29.00
6b	4120103B	Cordino fibrocaramico Ø 10 mm (50 mt.) / Ceramic fibre cord Ø 10 mm (50 m) / Keramikfaserschnur Ø 10 mm (50 m) / Cordon en fibre céramique Ø 10 mm (50 m) / Junta a cuerda de fibra cerámica Ø 10 mm (50 m)	167.00
6c	41201031	Kit sostituzione cordino (cordino+silicone) Ø 10 mm / Cord replacement kit (cord + silicone) Ø 10 mm / Schnuraustauschsatz (Schnur+Silikon) Ø 10 mm / Kit remplacement cordon (cordon + silicone) Ø 10 mm / Kit sustitución junta a cuerda (junta a cuerda+silicón) Ø 10 mm	43.00

# MCZ GROUP

## MUSA AIR

Componenti interni elettronici e meccanici / Electronic and mechanical internal components / Interne elektronische und mechanische Bauteile / Composants électroniques et mécaniques internes / Componentes internos electrónicos y mecánicos

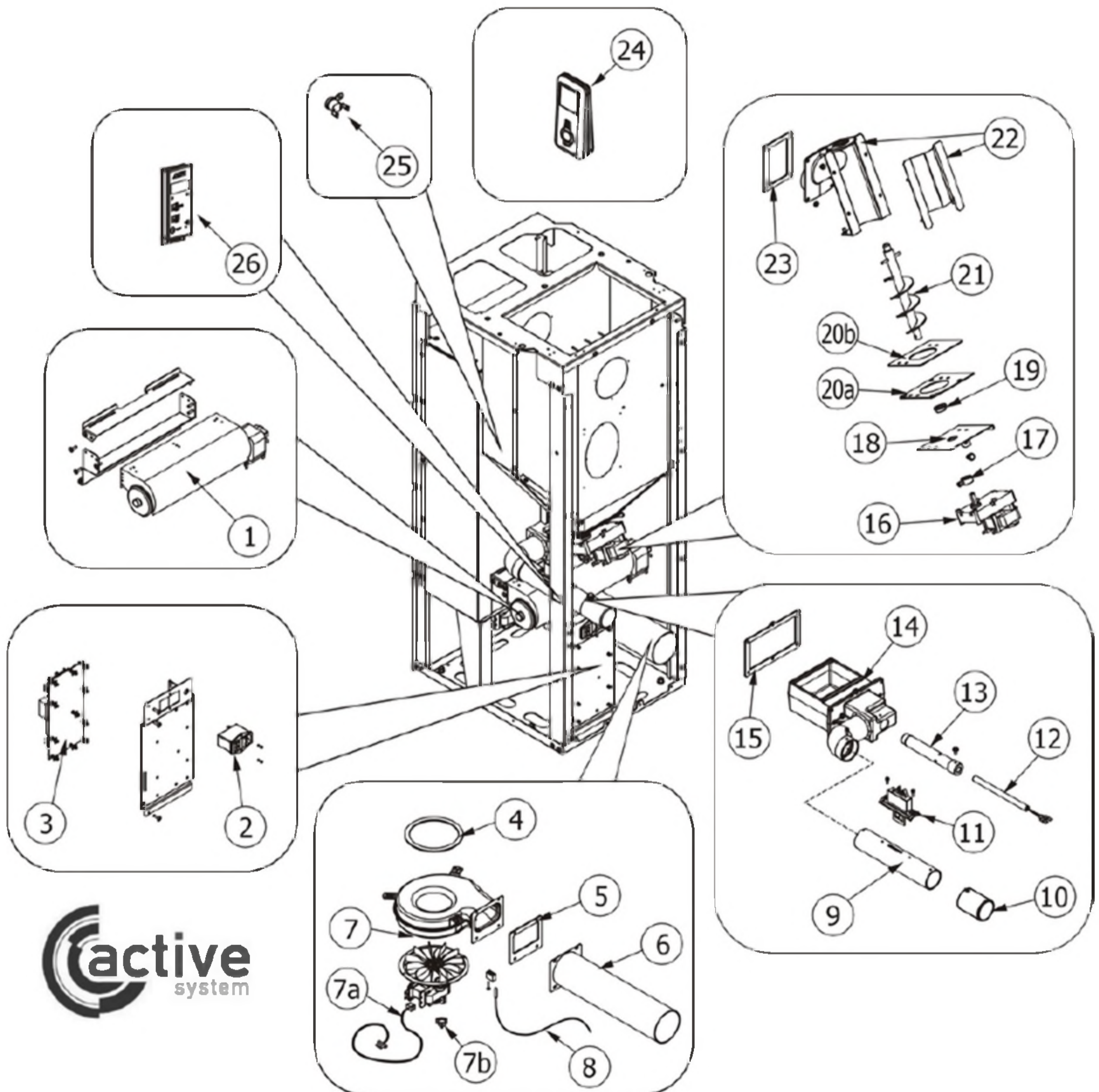

## MUSA AIR

Componenti interni elettronici e meccanici / Electronic and mechanical internal components / Interne elektronische und mechanische Bauteile / Composants électroniques et mécaniques internes / Componentes internos electrónicos y mecánicos

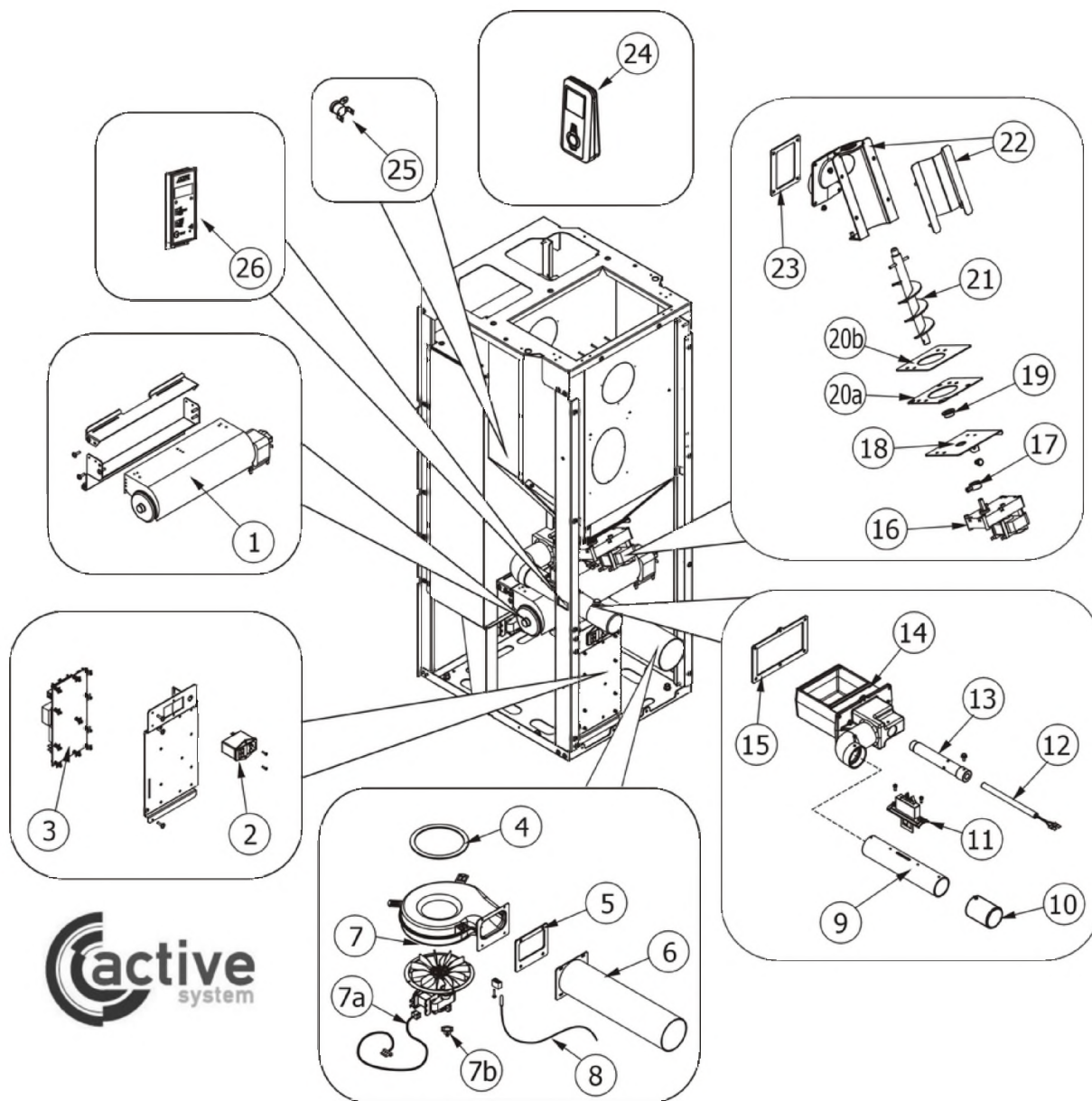

N°	Codice/Code	Descrizioni / Description / Beschreibung / Description / Descripción	Prezzo (€)
1	41451002800	Ventilatore aria calda / Warm air fan / Warmluftgebläse / Ventilateur air chaud / Ventilador aire caliente	74.00
2	4160459	Puisante accensione / On/Off button / Zündungstaste / Touche d'allumage / Botón encendido	37.00
3	41450907601	Scheda madre / Motherboard / Hauptplatine / Carte mère / Tarjeta madre	135.00
3	41801499750	Kit 868 / Kit 868 / Kit 868 / Kit 868 / Kit 868	192.00
4	41801002600	Guarnizione adesiva voluta fumi / Adhesive gasket smoke volute / Haftendichtung Rauchvolute / Joint adhesive volute fumées / Junta adhesiva voluta humos	20.00
4	41801599850	Kit 50 guarnizioni / Kit 50 gaskets / Bausatz 50 Dichtungen / Kit 50 joints / Kit 50 juntas	800.00
5	418008030	Guarnizione / Gasket / Dichtung / Joint / Junta	21.00
6	416008010	Tubo uscita fumi / Smoke outlet pipe / Rohr Rauchabzug / Tuyau sortie fumées / Tubo salida humos	33.00
7	41451003202	Ventilatore aspirazione fumi / Smoke exhausted fan / Rauchabsauggebläse / Ventilateur aspiration fumées / Ventilador aspiración humos	106.00
7	41801102500	Guarnizione / Gasket / Dichtung / Joint / Junta	21.00

<b>7a</b>	<b>4160477</b>	Cavo ENCODER / ENCODER cable / Drehzahlmesser-kabel / Câble ENCODER / Cable ENCODER	<b>36.00</b>
<b>7b</b>	<b>41451209300</b>	Encoder per ventilatore fumi marchi LN2/SIT / Encoder for LN2/SIT smoke fan / Encoder für LN2/SIT Rauchgasgebläse / Encoder pour ventilateur des fumées marques LN2/SIT / Encoder para ventilador humos marcas LN2/SIT	<b>21.00</b>
<b>8</b>	<b>41450901800</b>	Sonda fumi Active System / Smoke sensor Active System / Rauchgasfühler ACTIVE SYSTEM / Sonde fumées ACTIVE SYSTEM / Sonda humos Active System	<b>37.00</b>
<b>9</b>	<b>41200901200</b>	Tubo ingresso aria / Air inlet pipe / Luftergangsrohr / Tuyau entrée air / Tubo entrada aire	<b>25.00</b>
<b>10</b>	<b>41401036100</b>	Filtro antipolvere / Anti-dust filter / Staubschutzfilter / Filtre antipoussière / Filtro de protección polvo	<b>21.00</b>
<b>11</b>	<b>41451205000</b>	Sensore aria completo / Complete air sensor / Kompletter Luftfühler / Capteur air complet / Sensor aire completo	<b>71.00</b>
<b>11</b>	<b>41450902200</b>	Cavo Flat sensore di portata / Flat cable air flow sensor / Flat Kabel Luftmengesensor / Câble flat capteur de débit / Cable flat sensor de aire	<b>19.00</b>
<b>12</b>	<b>41450905000</b>	Candeletta accensione pellet / Pellet ignition sparkplug / Zündkerze Pelletzündung / Bougie d'allumage pellet / Bujia encendido pellet	<b>45.00</b>
<b>12</b>	<b>41801599550</b>	Kit 50 candelette / 50 Sparkplugs kit / Bausatz 50 Zündkerzen / Kit 50 Bougies / Kit 50 Bujias	<b>1,800.00</b>
<b>13</b>	<b>41200903900</b>	Condotto candeletta / Sparkplug conduit / Zündkerzenkanal / Conduit bougie / Conducto bujia	<b>36.00</b>
<b>14</b>	<b>414008043</b>	Tasca braciere in ghisa / Combustion pot container / Brenntopfkasten aus Gusseisen / Récipient braséro / Contenedor brasero	-
<b>14</b>	<b>41401069141V</b>	Tasca braciere / Combustion pot container / Brenntopfkasten / Récipient braséro / Contenedor brasero	<b>164.00</b>
<b>15</b>	<b>418008027</b>	Guarnizione / Gasket / Dichtung / Joint / Junta	<b>22.00</b>
<b>16</b>	<b>4160278</b>	Motoriduttore 1,5 RPM / Reduction motor 1,5 RPM / Getriebemotor 1,5 RPM / Motoréducteur 1,5 TPM / Motorreductor 1,5 RPM	<b>94.00</b>
<b>17</b>	<b>4120398</b>	Connettore motoriduttore-coclea / Reduction motor-feed screw connector / Verbindung Getriebemotor-Schnecke / Connecteur motoréducteur-vis sans fin / Conector motorreductor-cóclea	<b>22.00</b>
<b>18</b>	<b>41400944351</b>	Base della coclea / Feed screw base / Untergestell der Förderschnecke / Base de la vis sans fin / Base de la cóclea	<b>25.00</b>
<b>19</b>	<b>4120614</b>	Boccola grafitata (2 pz) / Etched bush (2 pcs) / Graphitbuchse (2 Stck) / Bride graphitée (2 pcs) / Brida grafitada (2 pz)	<b>20.00</b>
<b>20a</b>	<b>4120615</b>	Guarnizione base della coclea / Feed screw base gasket / Dichtung Untergestell der Förderschnecke / Joint pour la base de la vis sans fin / Junta base de la cóclea	<b>19.00</b>
<b>20b</b>	<b>41400903310</b>	Flangia condotto coclea / Base of feed screw conduit / Untergestell Rohrleitung der Förderschnecke / Base du conduit de la vis sans fin / Base de conducto de la cóclea	<b>20.00</b>
<b>21</b>	<b>41200901040</b>	Coclea di caricamento pellet / Pellet feed screw / Pelletsförderschnecke / Vis sans fin pour chargement du pellet / Cóclea de carga pellet	<b>46.00</b>
<b>22</b>	<b>41401077540V</b>	Condotto della coclea / Conduit of feed screw / Rohrleitung der Förderschnecke / Conduit de la vis sans fin / Conducto de la cóclea	<b>81.00</b>
<b>24</b>	<b>41450901500</b>	Telecomando / Remote control / Fernbedienung / Télécommande / Mando a distancia	-
<b>24</b>	<b>41451106000</b>	Telecomando / Remote control / Fernbedienung / Télécommande / Mando a distancia	<b>123.00</b>
<b>24</b>	<b>41801499750</b>	Kit 868 / Kit 868 / Kit 868 / Kit 868 / Kit 868	<b>192.00</b>
<b>23</b>	<b>418008029</b>	Guarnizione / Gasket / Dichtung / Joint / Junta	<b>21.00</b>
<b>25</b>	<b>412007004</b>	Clickson 110°C / Clickson 110°C / Clickson 110°C / Clickson 110°C / Clickson 110°C	<b>20.00</b>
<b>26</b>	<b>41450900700</b>	Pannello di emergenza / Emergency panel / Notfalldisplay / Tableau de secours / Panel d'emergencia	<b>79.00</b>
<b>26</b>	<b>41801499750</b>	Kit 868 / Kit 868 / Kit 868 / Kit 868 / Kit 868	<b>192.00</b>