

## ERICA

Componenti esterni / Internal components / Bauteile / Composants extérieurs / Componentes externos

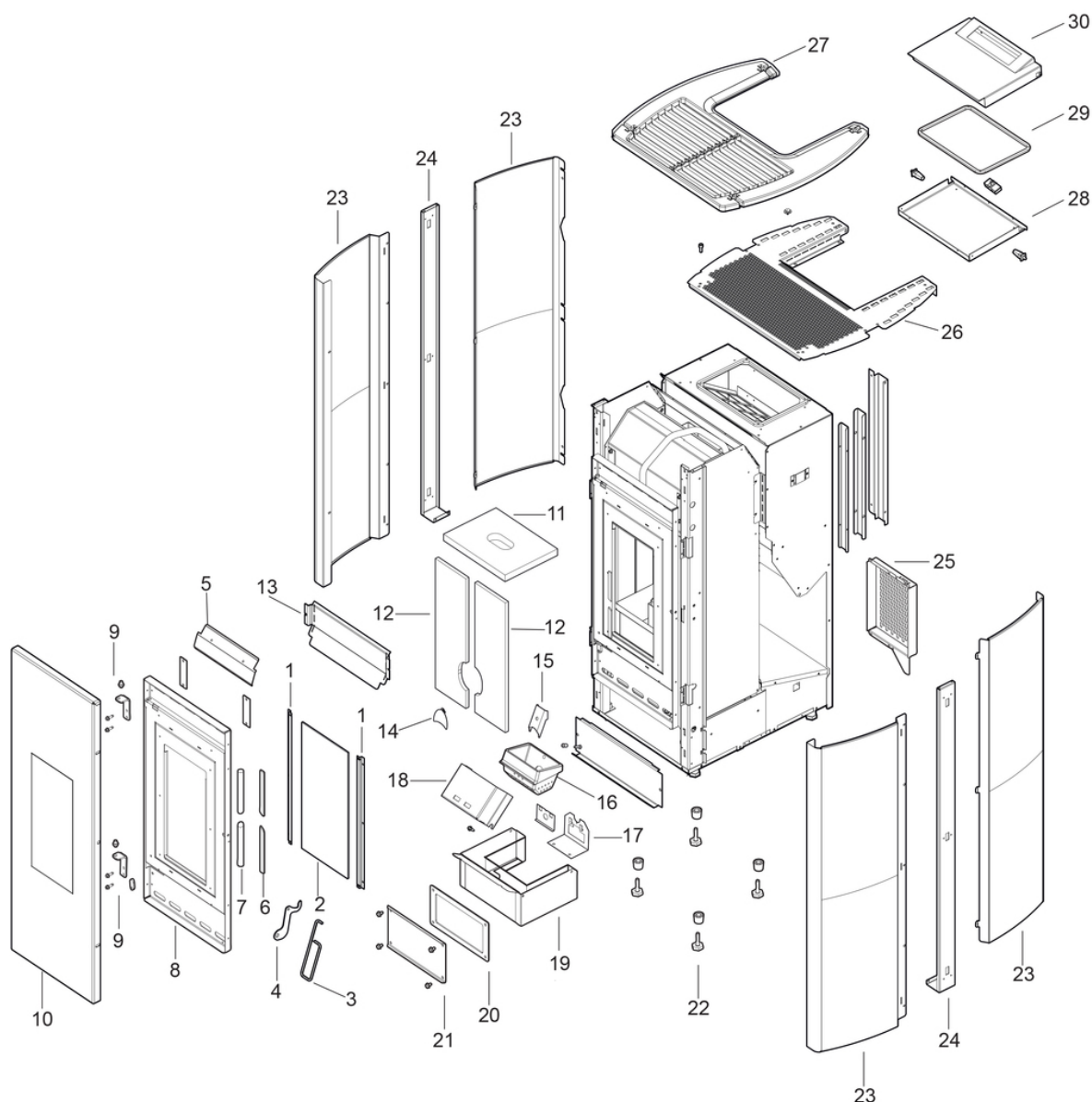

N°	Codice/Code	Descrizioni / Description / Beschreibung / Description / Descripción	Prezzo (€)
1	4D241140163	Profilo fermavetro / Fastening bracket profile / Haltebügel für Scheibenfest. Profil / Profil patte de fixation / Perfil fermacristal	23.00
1	4D241140163	Profilo fermavetro / Fastening bracket profile / Haltebügel für Scheibenfest. Profil / Profil patte de fixation / Perfil fermacristal	23.00
2	4D170140010	Vetro ceramico 385x175x4 mm / Ceramic glass 385x175x4 mm / Glasskeramikscheibe 385X175X4 mm / Vitreeceramique 385x175x4mm / Cristal cerámico 385x175x4 mm	48.00
2	4D170157040	Vetroceramico 379X193X4 / Ceramic glass 379X193X4 / Glaskeramikscheibe 379X193X4 / Vitreceramique 379x193x4 mm / Cristal cerámico 379x193x4 mm	67.50
3	4D12013060	Gancio "Mano fredda" / Hook "Cold hand" / Haken "Kalte Hand" / Crochet "Main froide" / Gancho "Mano fría"	16.00
4	4D24014066161	Maniglia nera / Handle / Griff / Poignée / Tirador	14.50
4	4D24015868161	Maniglia nera / Handle / Griff / Poignée / Tirador	23.50
5	4D242157093	Deflettore aria porta / Air deflector / Luftleitblech / Déflecteur aire / Deflector aire	23.00
6	4D18013008A	Guarnizione adesiva vetro 10x3 5 mt / Adhesive Gasket 10X3 (5Mt) / Haftenddichtung 10X3 (5Mt) / Joint Adhesive 10X3 (5Mt) / Junta Adhesiva 10X3 (5Mt)	20.50
6	4D18013008B	Guarnizione adesiva vetro 10x3 50 mt / Adhesive Gasket 10X3 (50Mt) / Haftenddichtung 10X3 (50Mt) / Joint	90.50

		Adhesive 10X3 (50Mt) / Junta Adhesiva 10X3 (50Mt)	
7	4D18013021A	Guarnizione Ø10 5mt / Gasket Ø10 5Mt / Dichtung Ø10 5Mt / Joint Ø10 5Mt / Junta Ø10 5Mt	20.50
7	4D18013021B	Guarnizioe Ø10 50mt / Gasket Ø10 50Mt / Dichtung Ø10 50Mt / Joint Ø10 50Mt / Junta Ø10 50Mt	90.00
8	4D24014064461	Telaio porta nero / Cadre porte noir / Schwarze Türrahmen / Cadre porte noir / Armazón puerta negro	80.00
9	4D24015703361	Cerniera porta (2 pz) / Door Hinge (2 Pcs) / Türgriff (2 Stck) / Charnière Porte (2 Pcs) / Bisagra Puerta (2 Pcs)	31.00
9	4D24015703361	Cerniera porta (2 pz) / Door Hinge (2 Pcs) / Türgriff (2 Stck) / Charnière Porte (2 Pcs) / Bisagra Puerta (2 Pcs)	31.00
10	4D24015734361	Porta esterna / Complete External Door / Komplette Außentür / Porte Extérieure Complète / Puerta Exterior Completa	53.00
10	4D245GP15012	Porta completa / Complete door / Komplette Tür / Porte complète / Puerta completa	182.50
10	4D24015841361	Kit decompressione camera di combustione / Pressure relief kit / Bausatz Überdruckablauf Brennkammer / Kit decompression chambre de combustion / Kit decompressión cámara de combustión	0.00
11	4D115157020	Tavella vermiculite superiore / Upper vermiculite panel / Obere Paneel aus Vermiculite / Panneau supérieur vermiculite / Panel superior vermiculite	28.00
12	4D115157040	Schiena vermiculite (pz.2) / Vermiculite back panel (2pcs) / Hintere Paneel aus Vermiculite (2 stk) / Panneau postérieur vermiculite (2 pcs) / Panel posterior vermiculite	27.50
12	4D115157040	Schiena vermiculite (pz.2) / Vermiculite back panel (2pcs) / Hintere Paneel aus Vermiculite (2 stk) / Panneau postérieur vermiculite (2 pcs) / Panel posterior vermiculite	27.50
13	4D24015769361	Frangicalore frontale / Frontal deflector / Vordere Leitblech / Déflecteur Frontal / Deflector Frontal	38.50
14	4D2401303101	Coperchio caduta pellet / Cover / Deckel / Couvercle / Tapa	16.50
15	4D242140053	Antiscoppio / Anti-explosion / Anti-explosion / Anti-explosion / Anti-explosión	22.50
16	4D13016602061	Braciere in ghisa 8-22kw / Cast iron grate / Brennertopf aus Gusseisen / Brasero en fonte / Brasero en arrabio	32.00
17	4D242157153	Farfalla automatica / Air Flux Regulator / Clapet Ventil - Luftflussregler / Clapet / Regolador Flujo Aire	27.50
18	4D24015747361	Deviatore fumi nero / Black Smoke Conveyor 500° / Schwarz Rauchluftblech 500° / Convoyeur De Fumées Noir 500° / Conductor De Humos Negro 500°	34.50
19	4D24015728461	Cassetto cenere nero / Ash Drawer / Ashenkasten / Tiroir A Cendres / Cajón Ceniza	48.00
20	41800900600	Guarnizione / Gasket / Dichtung / Joint / Junta	20.00
21	4D24015762361	Chiusura fumi / Smoke Compartment Inspection Plug / Inspektionskappe Rauchabzug / Clapet Inspection Compart.Fumé / Tapón Inspección Compartim.Humos	26.50
22	4D12013006	Piedino regolabile nero M8x35 (4 pz) / Adjustable Feet (4 Pcs.) / Einstellbare Füße (4 Stck.) / Vérins Réglables (4 P.Ces.) / Pies Regulables (4 Piezas)	15.00
23	6915016	Rivestimento metal grigio / Metal Grey cladding / Verkleidung Grey metal / Habillage metal Grey / Revestimiento metal Grey	120.00
23	6915018	Rivestimento metal nero / Metal Black cladding / Verkleidung Black metal / Habillage metal Black / Revestimiento metal Black	120.00
23	6915019	Rivestimento metal bordeaux / Metal Bordeaux cladding / Verkleidung Bordeaux metal / Habillage metal Bordeaux / Revestimiento metal Bordeaux	120.00
23	6915026	Rivestimento metal bianco / Metal white cladding / Verkleidung White metal / Habillage metal White / Revestimiento metal White	120.00
24	4D241157163	Montante laterale / Lateral Vertical Rod / Seitlich Montageleiste / Montant Latéral / Montante Lateral	34.00
24	4D241157163	Montante laterale / Lateral Vertical Rod / Seitlich Montageleiste / Montant Latéral / Montante Lateral	34.00
25	4D241157123	Carter ispezione posteriore / Rear Casing / Hinteres Gehäuse / Carter Postérieur / Cártter Trasero	32.50
26	4D24015733361	Sottocoperchio / Part under the cover / Stück unter die Deckel / Composent sous couvercle / Componente abajo tapa	51.50
27	4D18015701061	Top in ghisa / Cast iron top / Abdeckplatte aus Gusseisen / Dessus en fonte / Top de arrabio	105.00
28	4D241157093	Controcoperchio serbatoio / Lower Pellet Hopper Cover / Pelletbehälter untere Deckel / Couvercle Inferieur Réservoir / Tapa Inferior Depósito	32.50
29	4D18013016	Guarnizione 155x190 / Gasket 155x190 mm / Dichtung 155x190 mm / Joint 155x190 mm / Junta 155x190 mm	17.00
30	4D24015731463	Coperchio serbatoio pellet / Pellet Hopper Cover / Deckel Pelletbehälter / Couvercle Réservoir Pellet / Tapadera Depósito	45.00

## ERICA

Componenti interni / Internal components / Interne Bauteile / Composants internes / Componentes internos

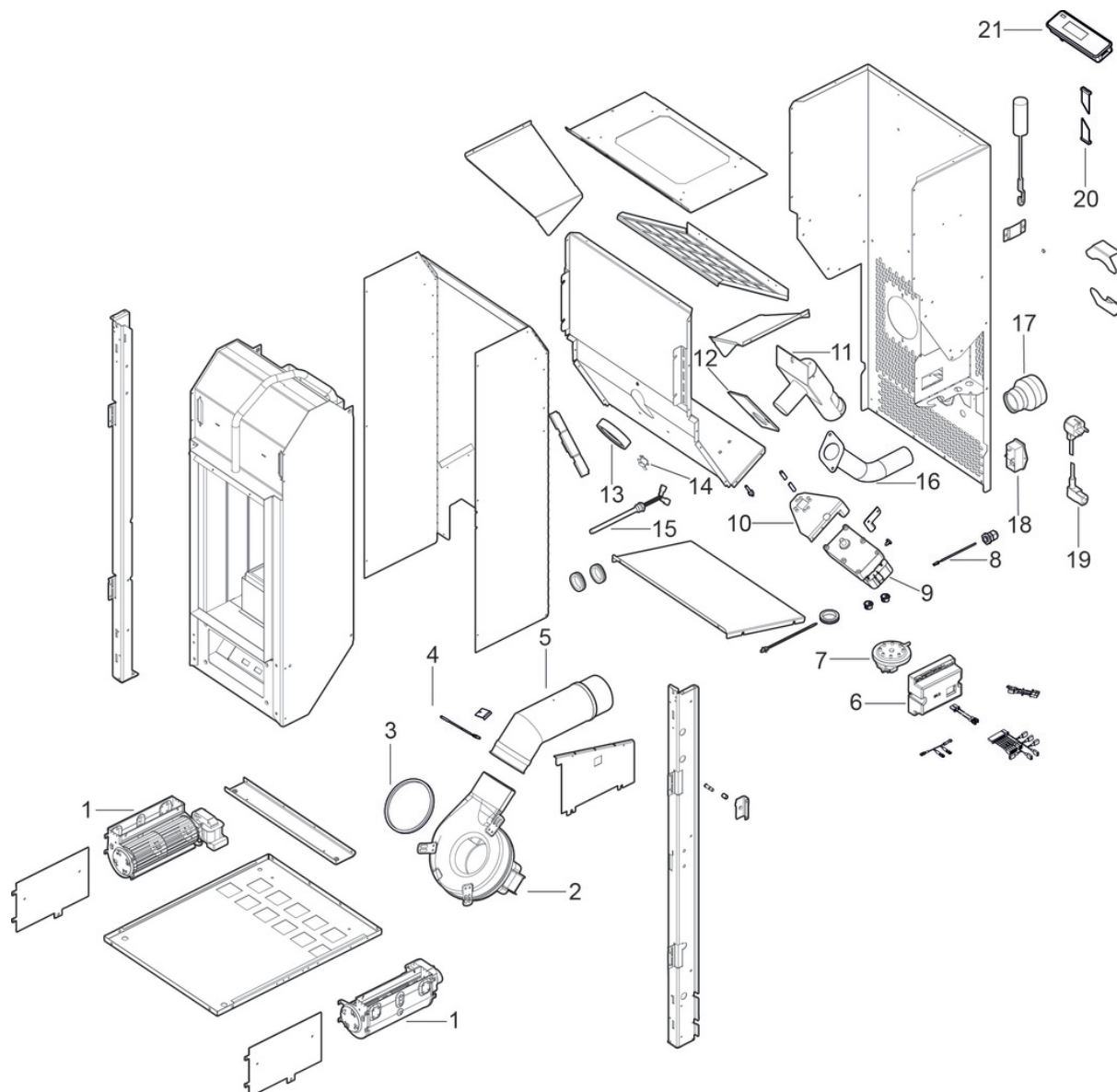

N°	Codice/Code	Descrizioni / Description / Beschreibung / Description / Descripción	Prezzo (€)
1	4D145157030	Ventilatore sinistro / Left air fan / Linke Luftgebläse / Ventilateur air gauche / Ventilador aire izquierdo	50.50
1	4D145157040	Ventilatore destro / Right air fan / Rechte Luftgebläse / Ventilateur air droit / Ventilador aire derecho	50.50
2	4D145140150	Ventilatore fumi stagno / Tin smoke fan / Hermetisch Dichtrauchgebläse / Ventilateur fumées étanche / Ventilador humos hermético	115.00
3	4D18013024	Guarnizione ventilatore fumi / Smoke exhaust fan gasket / Dichtung Rauchgebläse / Joint Ventilateur Fumées / Junta Ventilador Humos	18.50
4	4D145150060	Sonda fumi con cavo / Smoke sensor with cable / Rauchsonde mit Kabel / Sonde fumées avec câblr / Sonda humos con cable	24.50
5	4D160157030	Curva 45° / Bend 45° / Verlauf 45° / Coude 45° / Curva 45°	51.50
6	414513083001	Scheda madre N100 con software precaricato / Motherboard N100 with loaded software / Hauptplatine N100 mit eingegebenem Software / Carte mère N100 avec software préchargé / Tarjeta madre N100 con software precargado	101.00
7	4160482	Pressostato 0,4 mbar / Pressure gauge 0,4 mbar / Druckwächter 0,4 mbar / Pressostat 0,4 mbar / Presostato 0,4 mbar	35.00
8	4D145150100	Sonda ambiente / Temperature sensor / Raumtemperatursonde / Sonde ambiance / Sonda temperatura ambiente	20.00
9	41450901600	Motoriduttore 3,3 rpm Merkle Korff / Reduction motor 3,3 rpm Merkle Korff / Getriebemotor 3,3 RPM MERKLE	91.00

		KORFF / Motorréducteur 3,3 RPM MERKLE KORFF / Motorreductor 3,3 rpm Merkle Korff	
<b>9</b>	<b>4D145159010</b>	Motoriduttore / Reduction motor / Getriebemotor / Motoréducteur / Motorreductor	<b>111.00</b>
<b>10</b>	<b>4D2401302613</b>	Supporto coclea / Pellet feed screw bracket / Schenke Gestell / Support vis sans fin / Soporte coclea	<b>19.50</b>
<b>11</b>	<b>4D12013057</b>	Coclea per motoriduttore MK / Feed Screw Reduction Motor / Schnecke - Getriebemotor / Vis Sans Fin- Motoréducteur / Cóclea - Motorreductor	<b>79.50</b>
<b>12</b>	<b>4D18013004</b>	Guarnizione siliconica 100x108 / Silicon Gasket 100X108 / Silikondichtung 100X108 / Joint en silicone 100X108 / Junta en silicóna 100X108	<b>15.00</b>
<b>13</b>	<b>4D18013003</b>	Guarnizione Ø50 / Gasket Ø50 / Dichtung Ø50 / Joint Ø50 / Junta Ø50	<b>18.50</b>
<b>14</b>	<b>4D14513006</b>	Termostato / Thermostat / Thermostat / Thermostat / Termóstato	<b>20.00</b>
<b>15</b>	<b>4D14513002</b>	Candeletta / Sparkplug / Zündkerze / Bougie / Bujía	<b>32.00</b>
<b>16</b>	<b>4D160157050</b>	Tubo ingresso aria / Air inlet pipe / Air inlet pipe / Tuyau entrée air / Air inlet pipe	<b>36.50</b>
<b>17</b>	<b>4D180150030</b>	Raccordo tubo aria comburente / Combust.air aspiration connection / Verbrennungsluft Verbindung / Raccord aspiration air comburant / Raccor aspiración aire combustión	<b>23.50</b>
<b>18</b>	<b>4160193</b>	Pulsante accensione / On/Off button / Zündungstaste / Touche d'allumage / Botón encendido	<b>27.00</b>
<b>18</b>	<b>4D145181080</b>	* / * / * / * / *	<b>14.50</b>
<b>19</b>	<b>4D14513041</b>	Cavo + spina Schuko / Cable+Plug Schuko / Kabel+Stecker Schuko / Câble+Fiche Schuko / Cable+Espina Schuko	<b>16.00</b>
<b>20</b>	<b>4D14513031</b>	Cavo flat / Flat cable / Kabel flat / Câble flat / Cable flat	<b>32.50</b>
<b>21</b>	<b>41451200600</b>	Pannello comandi / Control panel / Bedienblende / Panneau de commande / Panel de mandos	<b>102.00</b>