

## MOOD

Componenti Struttura Esterna / External structure components / Bauteile Aussenkorpus / Composants structure externe / Componentes estructura externa

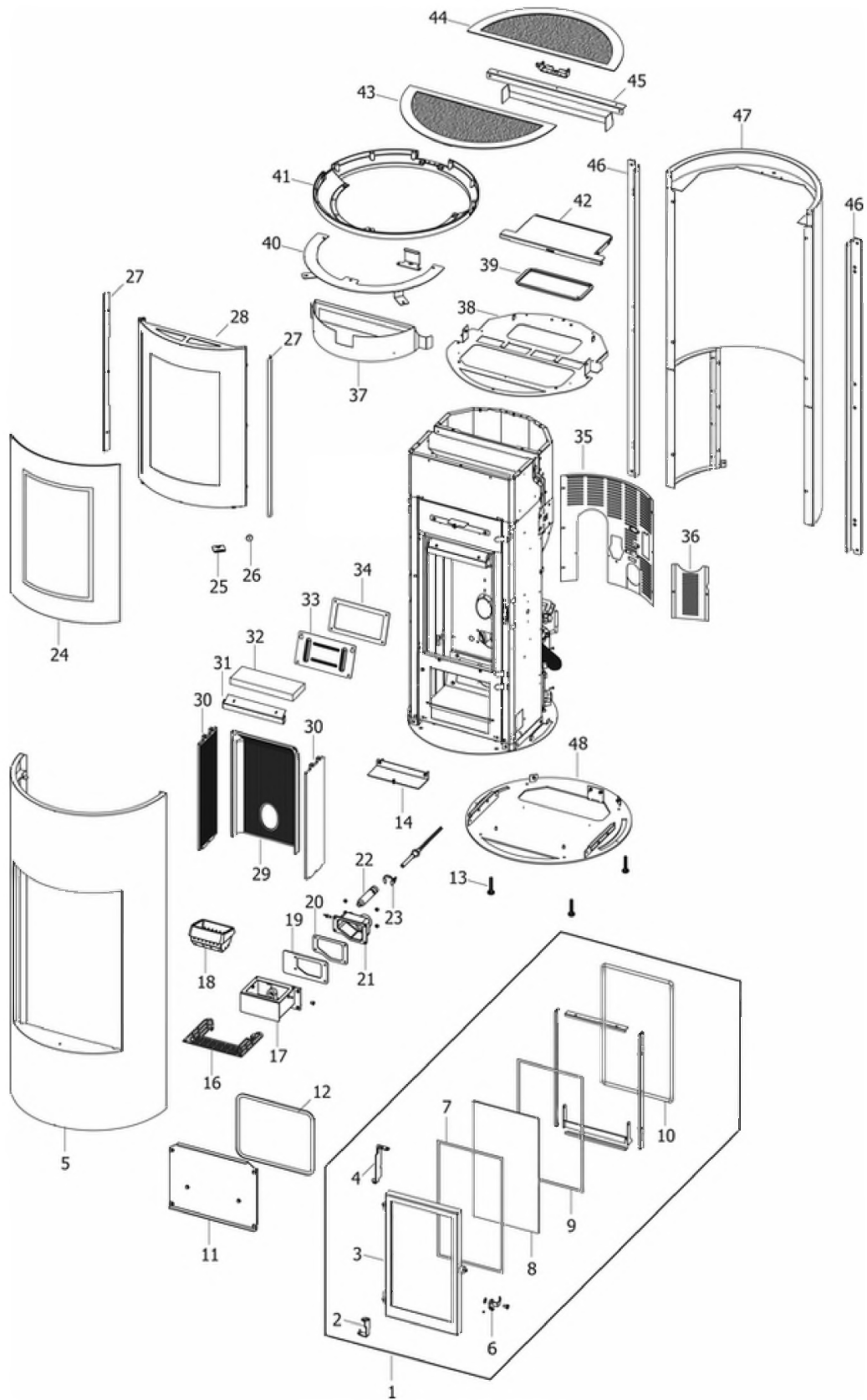

N°	Codice/Code	Descrizioni / Description / Beschreibung / Description / Descripcion	Prezzo (€)
1	437016084	Porta fuoco in lamiera / Metal sheet fireplace door / Blechfeuertür / Porte foyer en tôle / Puerta hogar de chapa	237.00
1	437017082	Porta fuoco in ghisa / Cast iron fireplace door / Feuertür aus Gusseisen / Porte foyer en fonte / Puerta hogar de arrabio	208.00
2	41411655340V	Cerniera inferiore / Lower hinge / Unteres Scharnier / Charnière inférieure / Bisagra inferior	24.00
2	41411731140V	Cerniera inf.porta ghisa / Lower hinge for cast iron door / Unterer Scharnier für Tür aus Guß / Charnière inférieure pour porte en fonte / Bisagra inferior por porta en arrabio	30.00
3	41421602241V	Telaio porta fuoco / Fire door frame / Feuertürrahmen / Cadre porte foyer / Armazón puerta de arrabio	200.00
3	41301602500V	Telaio porta fuoco / Fire door frame / Feuertürrahmen / Cadre porte foyer / Armazón puerta de arrabio	78.00
4	41411655431V	Cerniera superiore / Upper hinge / Oberes Scharnier / Charnière supérieure / Bisagra superior	19.00
4	41411731240V	Cerniera superiore / Upper hinge / Oberes Scharnier / Charnière supérieure / Bisagra superior	31.00
5	41411656040P	Pannello anteriore rivestimento Black / Front panel Black / Vordere Platte Black / Placque antérieure Black / Placa anterior Black	332.00
5	41411656140P	Pannello anteriore rivestimento Bronze / Front panel Bronze / Vordere Platte Bronze / Placque antérieure Bronze / Placa anterior Bronze	332.00
5	41411656240P	Pannello anteriore rivestimento Silver / Front panel Silver / Vordere Platte Silver / Placque antérieure Silver / Placa anterior Silver	379.00
6	41411616560	Maniglia porta nera / Door Handle / Türgriff / Poignée porte / Tirador	27.00
7	4120573A	Guarnizione a nastro 8 mm (5 mt.) per porta / Door strip gasket 8 mm (5 m) / Türbanddichtung 8 mm (5 m) / Joint ruban 8 mm (5 m) pour porte / Guarnición de cinta para puerta 8 mm (5 m)	32.00
7	4120573B	Guarnizione a nastro 8 mm (50 mt.) per porta / Door strip gasket 8 mm (50 m) / Türbanddichtung 8 mm (50 m) / Joint ruban 8 mm (50 m) pour porte / Guarnición de cinta para puerta 8 mm (50 m)	162.00
7	41801603300A	Guarnizione Ø5 5mt / Gasket Ø5 5mt / Dichtung Ø5 5mt / Joint Ø5 5mt / Junta Ø5 5mt	42.00
7	41801603300B	Guarnizione Ø5 50mt / Gasket Ø5 50mt / Dichtung Ø5 50mt / Joint Ø5 50mt / Junta Ø5 50mt	299.00
7	41801603300C	Guarnizione Ø5 5mt + silicone / Gasket Ø5 5mt + silic / Dichtung Ø5 5mt + Silikon / Joint Ø5 5mt + silic / Junta Ø5 5mt	63.00
8	41701600200	Vetroceramico / Glass / Glaskeramikscheibe / Vitrocéramique / Cristal cerámico	90.00
8	41701600300	Vetroceramico porta ghisa / Cast iron door glass / Glaskeramikscheibe Tür aus Gusseise / Vitrocéramique porte en fonte / Cristal cerámico puerta en arrabio	79.00
8	41411622030V	Profilo fermavetro / Fastening bracket profile / Haltebügel für Scheibebefestigung Profil / Profil patte de fixation / Perfil fermacristal	37.00
9	4120573A	Guarnizione a nastro 8 mm (5 mt.) per porta / Door strip gasket 8 mm (5 m) / Türbanddichtung 8 mm (5 m) / Joint ruban 8 mm (5 m) pour porte / Guarnición de cinta para puerta 8 mm (5 m)	32.00
9	4120573B	Guarnizione a nastro 8 mm (50 mt.) per porta / Door strip gasket 8 mm (50 m) / Türbanddichtung 8 mm (50 m) / Joint ruban 8 mm (50 m) pour porte / Guarnición de cinta para puerta 8 mm (50 m)	162.00
10	4120104A	Cordino fibroceramico Ø 12 mm (5 mt.) / Ceramic fibre cord Ø 12 mm (5 m.) / Keramikfaserschnur Ø 12 mm (5 m) / Cordon en fibre céramique Ø 12 mm (5 m) / Junta a cuerda de fibra cerámica Ø 12 mm (5 m)	36.00
10	4120104B	Cordino fibroceramico Ø 12 mm (50 mt.) / Ceramic fibre cord Ø 12 mm (50 m.) / Keramikfaserschnur Ø 12 mm (50 m) / Cordon en fibre céramique Ø 12 mm (50 m) / Junta a cuerda de fibra cerámica Ø 10 mm (52 m)	210.00
10	41201041	Kit sostituzione cordino (cordino+silicone) Ø 12 mm / Cord replacement kit (cord + silicon) Ø 12 mm / Schnur austauschset (Schnur+Silikon) Ø 12 mm / Kit remplacement cordon (cordon + silicone) Ø 12 mm / Kit sustitución junta a cuerda (junta a cuerda+silicón) Ø 12 mm	50.00
11	437016050	Tappo inferiore / Lower cover / Untere Abdeckung / Couvercle inférieur / Tapón inferior	35.00
12	4120573A	Guarnizione a nastro 8 mm (5 mt.) per porta / Door strip gasket 8 mm (5 m) / Türbanddichtung 8 mm (5 m) / Joint ruban 8 mm (5 m) pour porte / Guarnición de cinta para puerta 8 mm (5 m)	32.00
12	4120573B	Guarnizione a nastro 8 mm (50 mt.) per porta / Door strip gasket 8 mm (50 m) / Türbanddichtung 8 mm (50 m) / Joint ruban 8 mm (50 m) pour porte / Guarnición de cinta para puerta 8 mm (50 m)	162.00
13	41200906660	Piedini di appoggio (4 pz.) / Support feet (4 pcs.) / Einstellfüße (4 Stck.) / Vérins d'appui (4 p.es) / Pies de apoyo (4 piezas)	19.00
14	41411614630V	Supporto frontale inferiore / Lower panel support / Untere Vordere Gestell / Support panneau frontal inférieur / Soporte panel frontal inferior	18.00
16	41411613630V	Griglia focolare / Fire box grille / Feuerstellenrost / Grille foyer / Rejilla hogar	31.00
17	41411613140V	Tasca braciere / Combustion pot container / Brenntopfkasten / Récipient brasero / Contenedor brasero	79.00
18	41301502400V	Braciere ghisa / Cast iron grate / Brenntopf aus Gusseisen / Brasero en fonte / Brasero en arrabio	51.00
19	41801601500	Guarnizione tasca braciere / Combustion pot container gasket / Brenntopfkasten Dichtung / Joint récipient brasero / Junta contenedor brasero	18.00
20	41801602300	Guarnizione codolo / Gasket / Dichtung / Joint / Junta	19.00
21	41311600100	Codolo / Tool chuck / Einspannschaft / Outil d'emmanchement / Mango	29.00

22	41601601000	Condotto candeletta / Sparkplug Conduit / Zündkerzenkanal / Conduit Bougie / Conducto Bujía	27.00
23	41201601500	Anello arresto candeletta / Sparkplug stop / Zündkerzestopper / Butée bougie / Tope bujía	24.00
24	41701500760	Vetroceramico / Ceramic glass / Glaskeramikscheibe / Vitre céramique / Cristal cerámico	412.00
24	41701802000	Vetro temperato / Tempered glass / Gehärtete Glasscheibe / Vitre trempé / Cristal templado	165.00
25	41411617360	Maniglia porta esterna nera / External door handle / Außentür Griff / Poignée porte extérieure / Tirador puerta exterior	18.00
26	41801657900	Magneti (pz.2) / Magnet (pcs.2) / Magnet (stk. 2) / Aimant (pcs.2) / Imán (pz.2)	22.00
27	41411655030P	Fermavetro per vetro ceramico / Glass fastening bracket for feramic glass / Haltebügel für Scheibefestigung für Glaskeramikscheibe / Etrier de fixation vitre pour vitre céramique / Retendor del cristal para cristal cerámico	26.00
27	41411655030P	Fermavetro per vetro ceramico / Glass fastening bracket for feramic glass / Haltebügel für Scheibefestigung für Glaskeramikscheibe / Etrier de fixation vitre pour vitre céramique / Retendor del cristal para cristal cerámico	26.00
27	4141165503100	Fermavetro per vetro temperato / Glass fastening bracket for tempered glass / Haltebügel für Scheibefestigung für gehärtete Glasscheibe / Etrier de fixation vitre pour vitre trempé / Retendor del cristal para cristal templado	39.00
27	4141165503100	Fermavetro per vetro temperato / Glass fastening bracket for tempered glass / Haltebügel für Scheibefestigung für gehärtete Glasscheibe / Etrier de fixation vitre pour vitre trempé / Retendor del cristal para cristal templado	39.00
28	41421605240V	Porta estetica / Aesthetic door / Ästhetische Tür / Porte esthétique / Puerta estética	99.00
29	41301502600V	Schiena ghisa / Cast iron back / Rückwand aus Gusseisen / Dosseret en fonte / Parte trasera en arrabio	71.00
29	41411613530V	Deflettore pellet / Pellet deflector / Pellet Leitblech / Déflecteur pellet / Deflector pellet	23.00
30	41301502500V	Fianco ghisa / Cast iron side / Seite aus Guß / Côté en fonte / Placa lateral de arrabio	49.00
30	41301502500V	Fianco ghisa / Cast iron side / Seite aus Guß / Côté en fonte / Placa lateral de arrabio	49.00
31	41411615430V	Deflettore aria / Air deflector / Luftleitblech / Déflecteur aire / Deflector aire	26.00
32	41151600200	Deflettore focolare in vermiculite / Vermiculite deflector / Leitblech aus Vermiculite / Déflecteur en vermiculite / Deflector en vermiculite	22.00
33	41401339610	Tappo ispezione vano fumi / Smoke compartment inspection plug / Inspektionsdeckel Rauchabzug / Clapet inspection compartiment fumées / Tapón inspección compartimento humos	21.00
34	41800900600	Guarnizione / Gasket / Dichtung / Joint / Junta	21.00
34	41801599750	Kit 50 guarnizioni / Kit 50 gaskets / Bausatz 50 Dichtungen / Kit 50 joints / Kit 50 juntas	840.00
35	41411631940P	Pannello asportabile posteriore / Amovable rear panel / Abnehmbares hintere Paneel / Panneau postérieur démontable / Panel posterior desmontable	82.00
36	41411615530P	Flangia pannello ispezione tonda / Inspection panel round flange / Inspektionklappe Rundflansch / Bride ronde trappe inspection / Brida redonda tapa inspección	21.00
37	41411655640V	Convogliatore superiore aria / Upper air conveyor / Obere Luftblech / Convoyeur air superieur / Conductor del aire superior	40.00
38	41411655140V	Supporto inferiore top / Lower top support / Untere Deckelhaltebügel / Support inférieur du dessus / Soporte inferior top	63.00
39	41801601400	Guarnizione coperchio serbatoio / Pellet hopper cover gasket / Deckel Pelletbehälter Dichtung / Joint couvercle réservoir pellet / Junta tapa depósito pellet	21.00
40	41411655940V	Supporto superiore top / Upper top support / Obere Deckelhaltebügel / Support supérieur du dessus / Soporte superior top	38.00
41	41311101161	Base top in alluminio / Aluminium top base / Untergestell Aluminium Top / Base top aluminium / Base top aluminio	99.00
42	437016134	Coperchio serbatoio / Hopper cover / Deckel Pelletbehälter / Couvercle réservoir / Tapa depósito	89.00
43	41411658151	Top anteriore / Frontal top / Frontalabdeckplatte / Dessus antérieur / Top delantero	116.00
44	41411658640P	Top posteriore / Rear top / Hintereabdeckplatte / Dessus postérieur / Top posterior	89.00
45	41411658530P	SCIVOLO PELLETT / PELLET RAMP / PELLET RUTSCHE / GLISSÈRIE PELLETT / TOBOGÁN	64.00
46	41411657930V	Montante rivestimento / Vertical rod / Montageleiste / Montant / Montante	47.00
46	41411657930V	Montante rivestimento / Vertical rod / Montageleiste / Montant / Montante	47.00
47	41411657040P	Pannello posteriore rivestimento Black / Rear panel Black / Hintere Platte Black / Placque postérieure Black / Placa trasera Black	292.00
47	41411657140P	Pannello posteriore rivestimento Bronze / Rear panel Bronze / Hintere Platte Bronze / Placque postérieure Bronze / Placa trasera Bronze	304.00
47	41411657240P	Pannello posteriore rivestimento Silver / Rear panel Silver / Hintere Platte Silver / Placque postérieure Silver / Placa trasera Silver	353.00
48	41421605040V	Basamento / Base / Basis / Base / Base	137.00

# MCZ GROUP

## MOOD

Componenti Struttura Esterna / External structure components / Bauteile Aussenkorpus / Composants structure externe / Componentes estructura externa

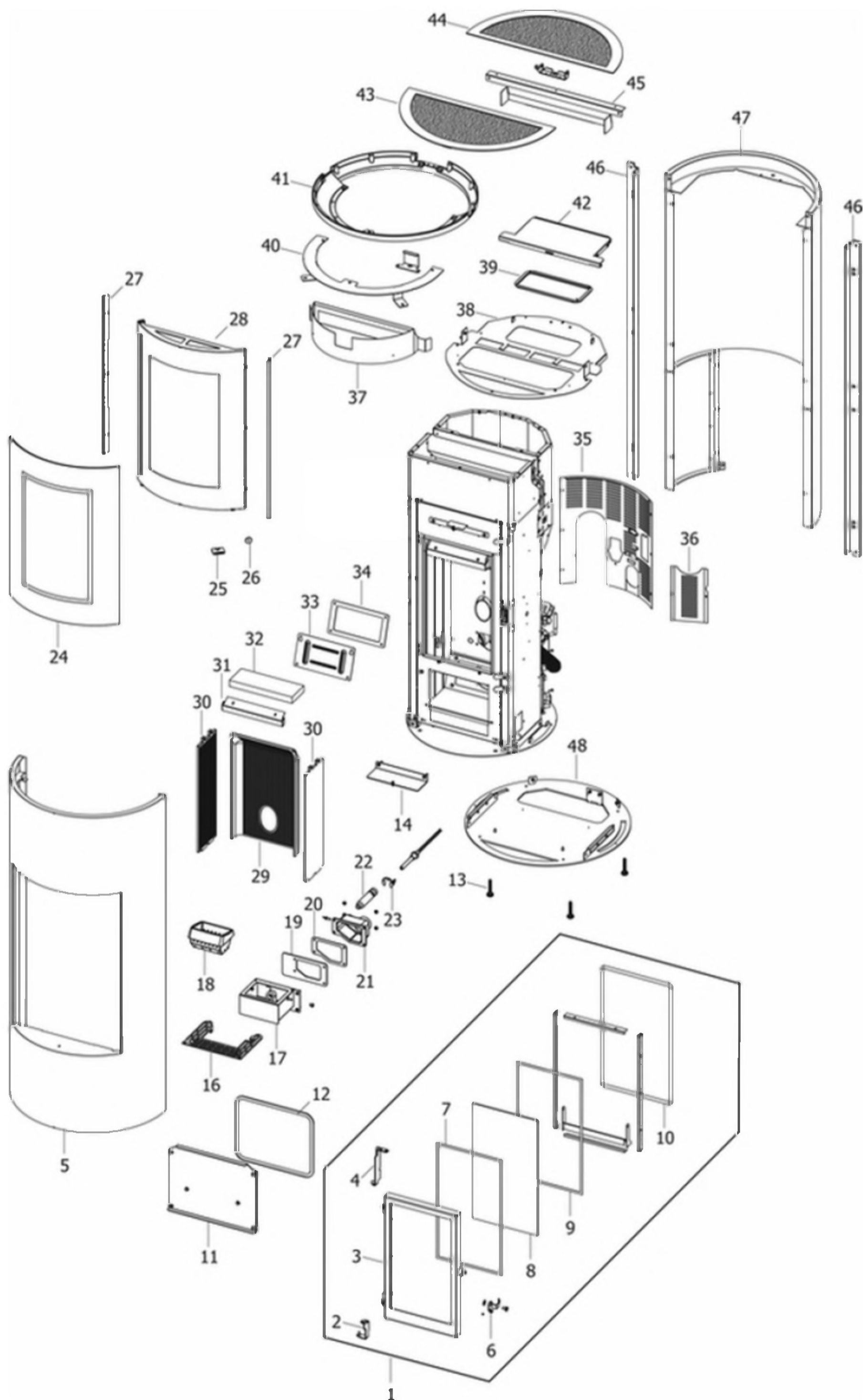

## MOOD

Componenti interni meccanici ed elettronici / Electronic and mechanic internal parts / Interne mechanische und elektronische Bauteile / Composants internes mécaniques et électroniques / Componentes internos electrónicos y mecánicos

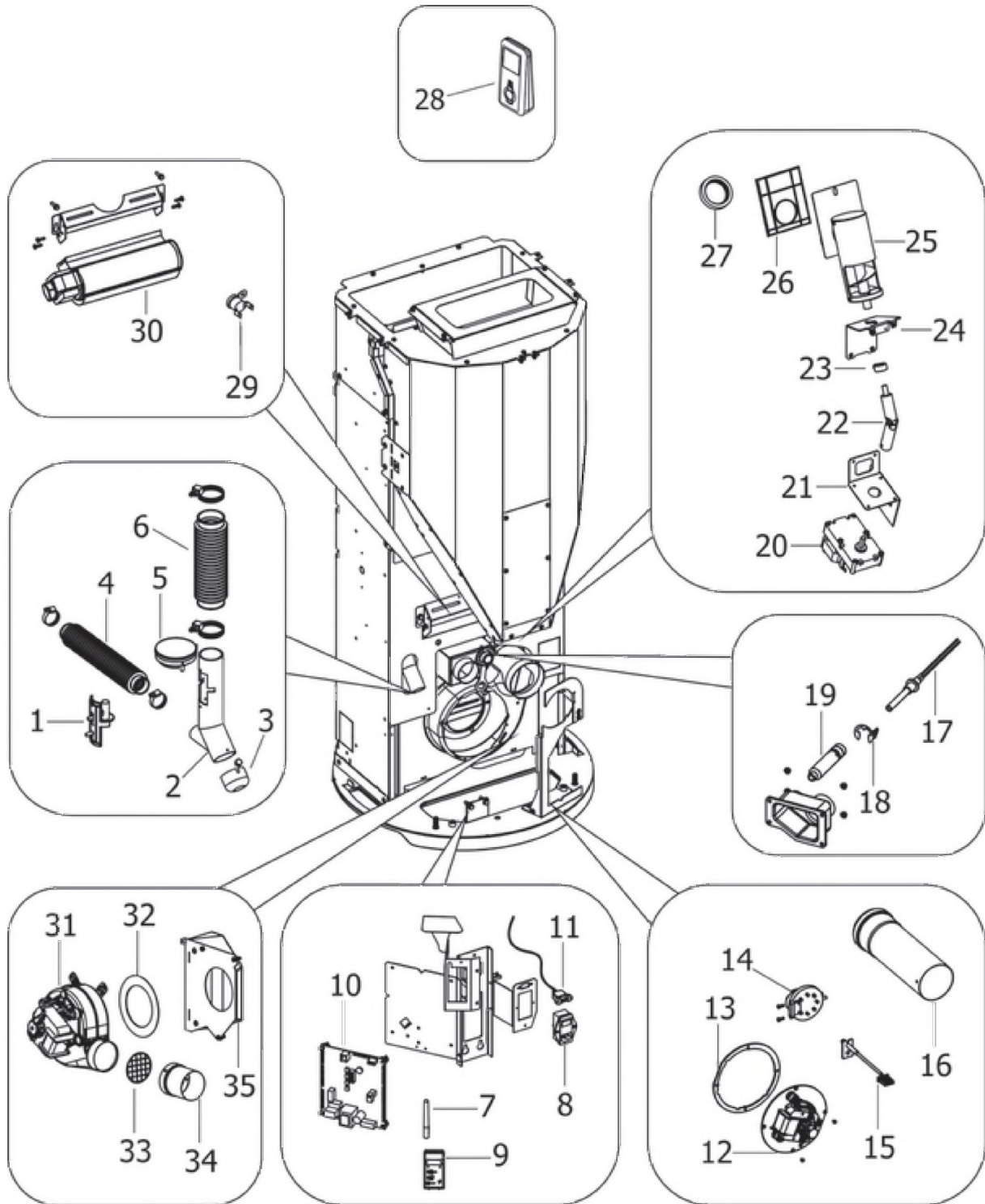

N°	Codice/Code	Descrizioni / Description / Beschreibung / Description / Description	Prezzo (€)
1	41601301850	Componente rilevamento portata aria / Air flow measure component / Bauteil für Messung der Luftmenge / Composent pour la mesuration de la quantité d'air / Componente por la medida de l'aire	34.00
2	41601601800V	Tubo aspirazione nero / Black air inlet pipe / Schwarz Lufteingangsrohr / Tuyau entrée d'air noir / Tubo entrada aire negro	48.00

3	41401036100	Filtro antipolvere / Anti-dust filter / Staubschutzfilter / Filtre antipoussière / Filtro de protección polvo	21.00
4	41801601900	Tubo aspirazione pulizia vetro / Inlet pipe for cleaning glass air / Glassreinigungs Lufteingangrohr / Tuyau entrée pour l'aire de nettoyage du vitre / Tubo entrada por l'aire de limpieza vidrio	62.00
5	41451303400	Trasduttore di pressione / Pressure transducer / Active-Wandler / Transducteur de pression / Transductor de pression	58.00
6	41801601700	Tubo aspirazione camera combustione / Combustion chamber aspiration tube / Verbrennungskammer Förderrohr / Tuyau aspiration air chambre de combustion / Tubo aspiración aire cámara de combustión	28.00
7	41451404700	Antenna 434 Mhz / Antenna 434 Mhz / Antenne 434 Mhz / Antenne 434 Mhz / Antena 434 Mhz	19.00
8	4160193	Pulsante accensione / On/Off button / Zündungstaste / Touche d'allumage / Boton encendido	28.00
9	41451404100	Pannello emergenza completo di antenna / Emergency display / Notfalldisplay mit Antenne / Panneau d'urgence avec antenne / Panel emergencia con antena	89.00
9	41801499750	Kit 868 / Kit 868 / Kit 868 / Kit 868 / Kit 868	192.00
10	41451303805	Scheda madre Hottoh 148 / Hottoh motherboard 148 / Hauptplatine Hottoh 148 / Carte mère Hottoh 148 / Tarjeta madre Hottoh 148	170.00
10	41451303807	Scheda madre Hottoh 148 / Hottoh motherboard 148 / Hauptplatine Hottoh 148 / Carte mère Hottoh 148 / Tarjeta madre Hottoh 148	210.00
10	41451600201	Cablaggio completo / Complete wiring / Komplette Verkabelung / Câblage complet / Cableado completo	82.00
10	41801499750	Kit 868 / Kit 868 / Kit 868 / Kit 868 / Kit 868	192.00
11	41451403200	Cavo USB da pannello L.500 / USB Cable from display L.500 / USB Kabel von Notfalldisplay L.500 / Câble USB de panneau L.500 / Cable USB del panel L.500	21.00
12	41451503200	Ventilatore fumi stagno / Air-tight smoke exhausted fan / Luftdichtes Rauchgasgebläse / Ventilateur fumées étanche / Ventilador humos hermético	82.00
12	41451703000	Encoder per ventilatore fumi marchio EBM / Encoder for EMB smoke fan / Encoder für EBM Rauchgasgebläse / Encoder pour ventilateur des fumées marque EBM / Encoder para ventilador humos marca EBM	22.00
12	41451209300	Encoder per ventilatore fumi marchi LN2/SIT / Encoder for LN2/SIT smoke fan / Encoder für LN2/SIT Rauchgasgebläse / Encoder pour ventilateur des fumées marques LN2/SIT / Encoder para ventilador humos marcas LN2/SIT	21.00
13	41801600800	Guarnizione ventilatore fumi / Smoke exhaust fan gasket / Dichtung Rauchabsauggebläse / Joint Ventilateur aspiration fumées / Junta ventilador aspiración humos	22.00
14	41451003700	Pressostato / Pressure switch / Druckschalter / Pressostat / Presostat	40.00
15	41451703600	Sonda fumi con flangia con morsettiera L.980 / Smoke sensor with flange with terminal board L.980 / Rauchsonde mit Flansche mit Klemmenbrett L.980 / Sonde fumées avec bride avec serre-câble L.980 / Sonda humos con brida con borne L.980	23.00
16	41601603000	Tubo Ø8 L.25 con guarnizione / Pipe Ø8 L.25 with gasket / Rohr Ø8 L.14 mit Dichtung / Tuyau Ø8 L.25 avec joint / Tubo Ø8 L.25 con guarnición	30.00
17	41451308101	Candeletta 315 Watt / Sparkplug 315 Watt / Zündkerze 315 Watt / Bougie 315 Watt / Bujia 315 Watt	77.00
17	41451308150	Kit 25 candelette 315 Watt / 25 Sparkplugs 315 Watt kit / Bausatz 25 Zündkerzen 315 Watt / Kit 25 Bougies 315 Watt / Kit 25 Bujias 315 Watt	1,637.00
18	41201601500	Anello arresto candeletta / Sparkplug stop / Zündkerzestopper / Butée bougie / Tope bujía	24.00
19	41601601000	Condotto candeletta / Sparkplug Conduit / Zündkerzenkanal / Conduit Bougie / Conducto Bujía	27.00
20	41451503100	Motoriduttore 2rpm / Gear motor 2rpm / Getriebemotor 2rpm / Motoréducteur 2rpm / Motorreductor 2rpm	102.00
21	41401609830	Supporto motoriduttore / Reduction motor support / Schneckenmotor Gestell / Support motoréducteur / Soporte motoreductor	20.00
22	41801604200	Cardano / Cardan / Kardan / Cardan / Cardán	49.00
23	4120398	Connettore motoriduttore-coclea / Reduction motor-feed screw connector / Verbindung Getriebemotor-Schnecke / Connecteur motoréducteur-vis sans fin / Conector motorreductor-cóclea	22.00
24	41401612630	Base coclea pellet / Feed screw base / Untergestell der Förderschnecke / Base de la vis sans fin / Base de la cóclea	26.00
25	41411800151	Gruppo alimentazione completo / Complete feed screw / Komplette Förderschnecke / Vis sans fin complète / Coclea de carga completa	113.00
26	41801600400	Guarnizione gruppo caricamento / Gasket / Dichtung / Joint / Junta	20.00
27	41801501900	Guarnizione silicone / Silicon gasket / Silikondichtung / Joint en silicone / Junta en silicóna	20.00
27	41801702600	Disaccoppiatore mesc. Marrone / Brown disengaging device / Braun Verängungrohr / Tuyau de découplage maron / Tubo de desvío marron	18.00
28	41451301203	Telecomando nero 434,5MHZ - Funzione impostabile da 0 a 3 Ventilatori / Black remote control 434,5MHZ - From 0 to 3 fan function / Schwarze Fernbedienung 434,5MHZ - Von 0 bis 3-Gebläse-Steuerung / Télécommande noire 434,5MHZ - Fonctionne à partir de 0 à 3 Ventilateurs / Mando a distancia negro 434,5MHZ - Función de 0 a 3 ventiladores	123.00
28	41801499750	Kit 868 / Kit 868 / Kit 868 / Kit 868 / Kit 868	192.00
29	412007004	Clickson 110°C / Clickson 110°C / Clickson 110°C / Clickson 110°C / Clickson 110°C	20.00

<b>30</b>	<b>41451600800</b>	Ventilatore aria / Air fan / Luftgebläse / Ventilateur air / Ventilador aire	<b>76.00</b>
<b>31</b>	<b>41451503300</b>	Ventilatore centrifugo / Air fun / Lufgebläse / Vantilateur air / Ventilador aire	<b>76.00</b>
<b>32</b>	<b>41801601600</b>	Guarnizione ventilatore / Fan gasket / Dichtung des Gebläses / Joint du ventilateur / Junta ventilador	<b>17.00</b>
<b>33</b>	<b>41331600410</b>	Griglia protezione prolunga ventilatore / Fan extension protection grille / Schutzgitter Gebläseverlängerung / Grille de protection prolongation ventilateur / Rejilla de protección prolongación ventilador	<b>20.00</b>
<b>34</b>	<b>41601601700V</b>	Prolunga ventilatore centrifugo / Fan extension / Gebläse Verlängerung / Rallonge ventilateur / Extensión ventilador	<b>33.00</b>
<b>35</b>	<b>41401609230</b>	Tamponazione completa / Complete filling / Komplett Stopfung / Tampon complèt / Taponado completo	<b>65.00</b>