

MCZ GROUP

POLAR HYDRO

Componenti Struttura Esterna / External structure components / Bauteile Aussenkorpus / Composants structure externe / Componentes estructura externa

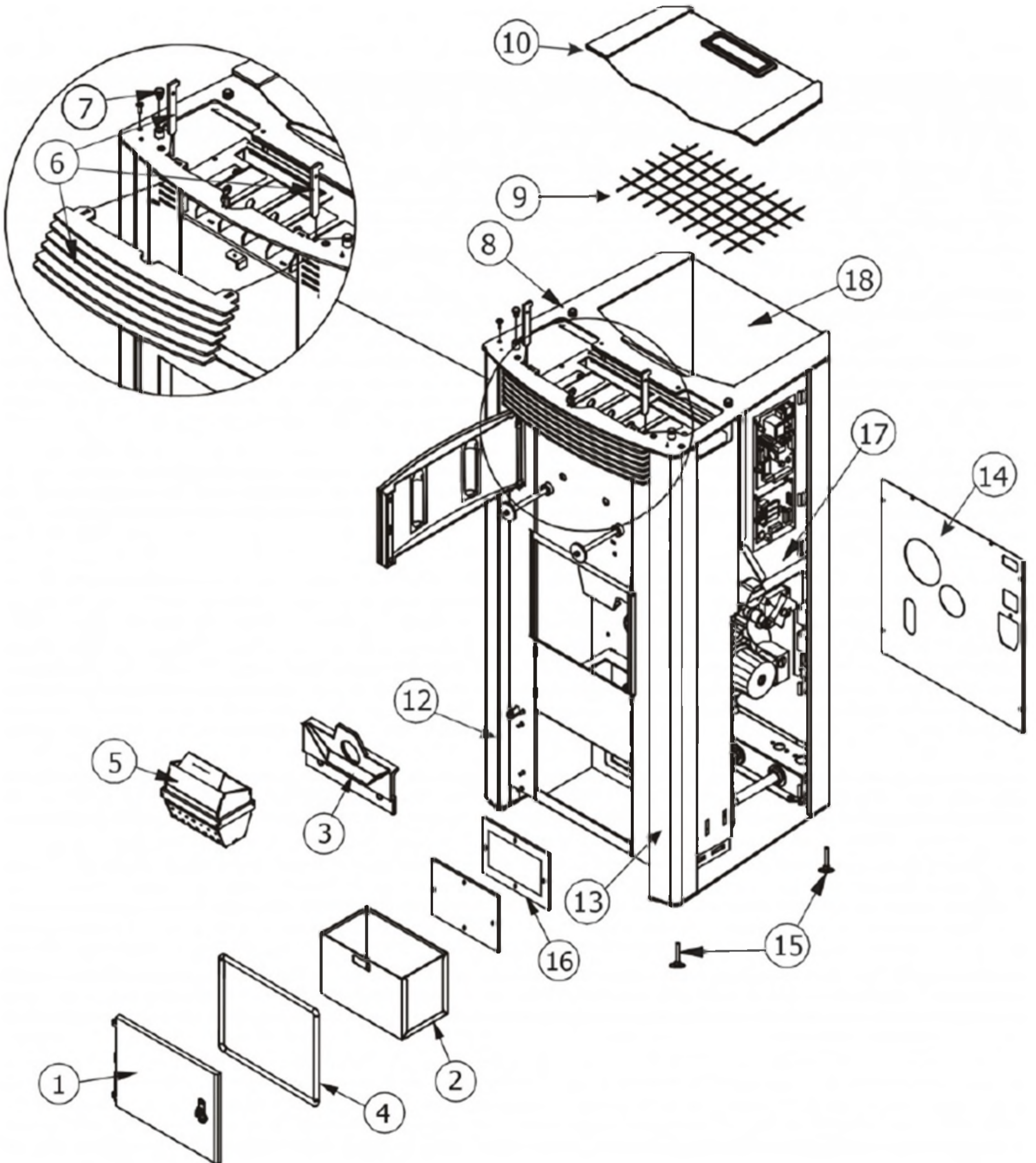

POLAR HYDRO

Componenti Struttura Esterna / External structure components / Bauteile Aussenkorpus / Composants structure externe / Componentes estructura externa

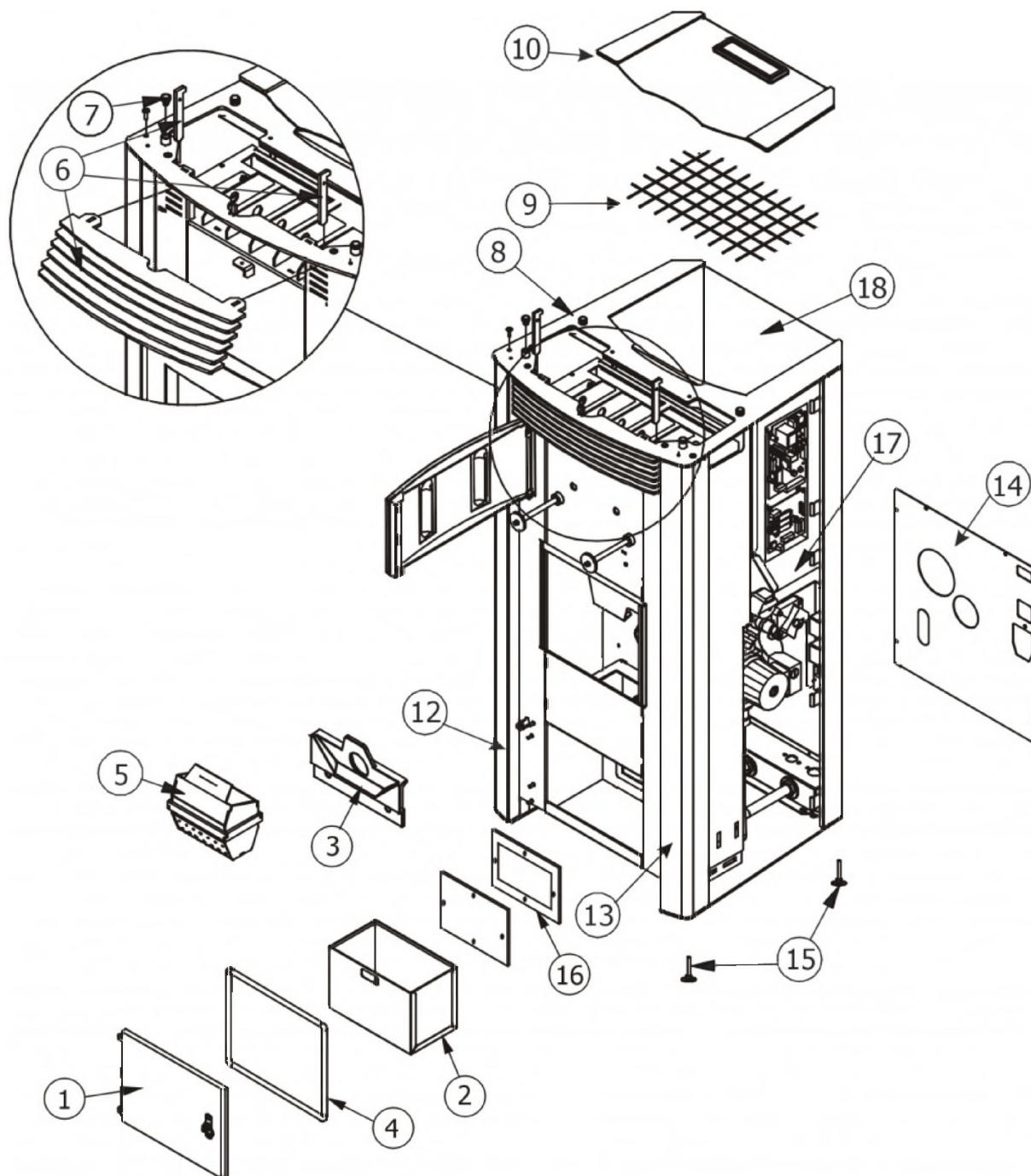

N°	Codice/Code	Descrizioni / Description / Beschreibung / Description / Descripción	Prezzo (€)
1	43660091	Porta cassetto cenere completa / Complete ash drawer door / Komplette Tür des Aschenkastens / Porte tiroir à cendres complète / Puerta completa cajón ceniza	109.00
1	41201214500	Chiusura Soutcho Brunita / Soutcho closure burnished / Soutcho-Verschluss brüniert / Fermeture Soutcho brunie / Cierre Soutcho bruñido	28.00
2	43640597	Cassetto cenere / Ash drawer / Aschenkasten / Tiroir à cendres / Cajón ceniza	55.00
3	43660090	Schiena interna in ghisa con viti di fissaggio / Cast iron internal back with fastening screws / Interne Rückwand aus Gusseisen mit Befestigungsschrauben / Dossieret en fonte avec vis de fixation / Parte trasera interna en arrabio con tornillos de fijación	67.00
4	4120102A	Cordino fibroceramico Ø 8 mm (5 mt.) / Ceramic fibre cord Ø 8 mm (5 m) / Keramikfaserschnur Ø 8 mm (5 m) /	29.00

		Cordon en fibre céramique Ø 8 mm (5 m) / Junta a cuerda de fibra cerámica Ø 8 mm (5 m)	
5	4130870	Braciere completo in ghisa / cast iron combustion pot / Kompletter Brennertopf aus Gusseisen / Brasero complet en fonte / Brasero completo de arrabio	166.00
6	43640492	Griglia frontale uscita aria / Front air outlet grille / Vorderes Gitter Luftaustritt / Grille antérieure sortie air / Rejilla frontal salida aire	169.00
7	4120180	Gommini paracolpi (4 pz) / Rubber bumpers (4 pcs.) / Schlagschutzgummi (4 Stck) / Pièces caoutchouc antichoc (4 pcs) / Cauchitos anti-golpes (4 pz)	21.00
8	43640657	Top in acciaio nero verniciato / Black painted steel top / Abdeckplatte aus Stahl Schwarz lackiert / Dessus en acier laqué noir / Top en acero negro barnizado	107.00
9	4120783	Griglia protezione / protection grille / Schutzgitter / Grille de protection / Rejilla de proteccion	25.00
10	43640593	Coperchio serbatoio (senza pannello) / Hopper cover (without display) / Deckel Pelletbehälter (ohne Display) / Couvercle réservoir (sans panneau) / Tapa depósito (sin panel)	79.00
12	43640604	Montante SX verniciato nero / L.black painted rod / LI.Montageleiste schwarz lackiert / Montant laqué noir G. / Montante IZDO negro barnizado	43.00
13	43640603	Montante DX verniciato nero / R.black painted rod / RE. Schwarz lackierte Montageleiste / Montant laqué noir D. / Montante DCHO negro barnizado	44.00
14	43640655	Schiena in acciaio / Steel back / Stahlrückwand / Dossieret en acier / Parte trasera en acero	40.00
15	4120618	Piedini di appoggio (4 pz) / Support feet (4 pcs) / Einstellfüße (4 Stck) / Vérins d'appui (4 pcs) / Pies de apoyo (4 pz)	20.00
16	41801209600	Guarnizione / Gasket / Dichtung / Joint / Junta	20.00
17	43640654	Serbatoio del pellet / Pellet hopper / Pelletbehälter / Réservoir pellet / Depósito pellet	66.00
18	436405901	Schiena esterna in acciaio / Steel external back / Aussenrückwand aus Stahl / Dossieret extérieur en acier / Panel trasero externo en acero	111.00

MCZ GROUP

POLAR HYDRO

Porta fuoco / Fire door / Feuertür / Porte foyer / Puerta hogar

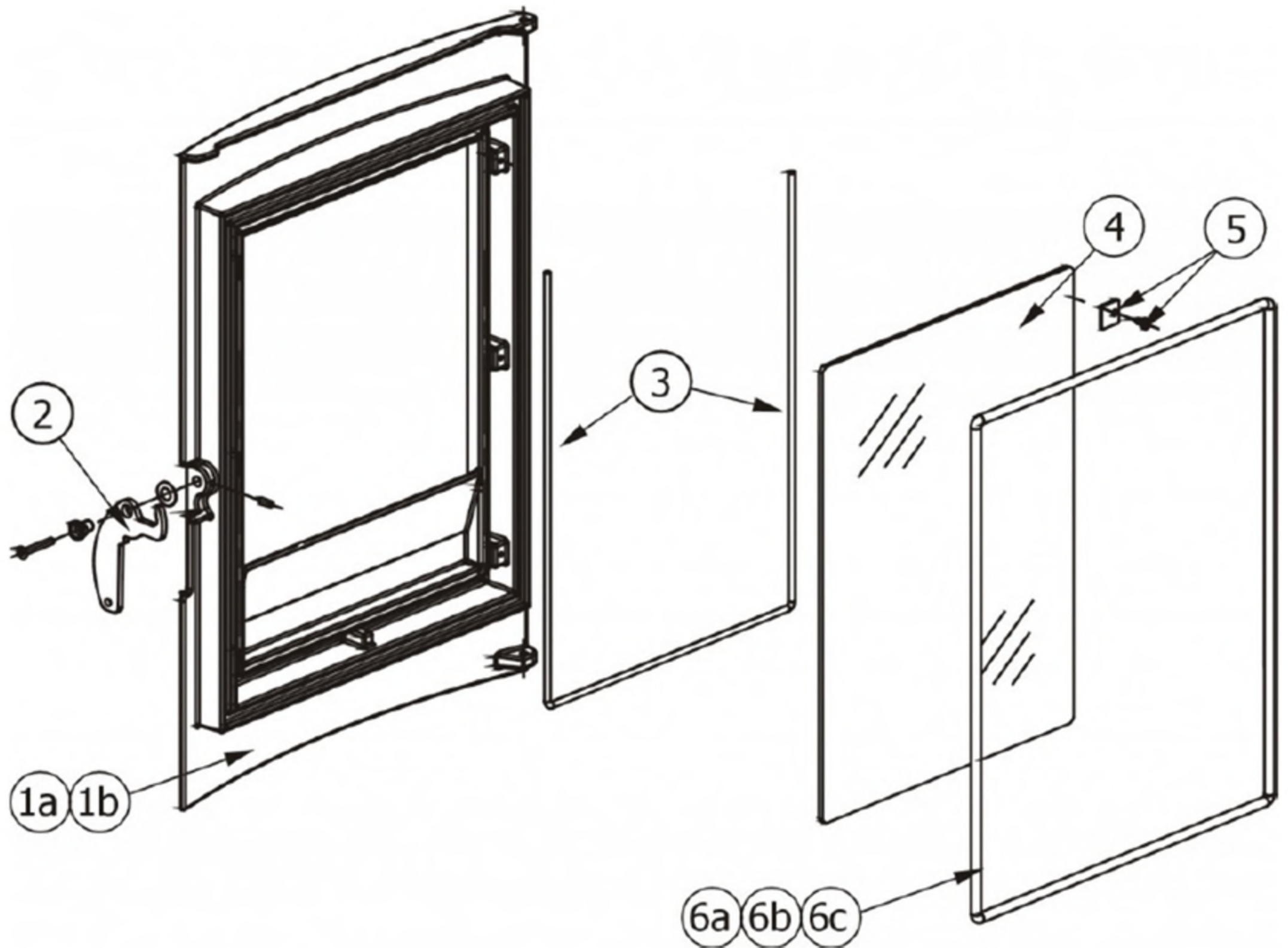

POLAR HYDRO

Porta fuoco / Fire door / Feuertür / Porte foyer / Puerta hogar

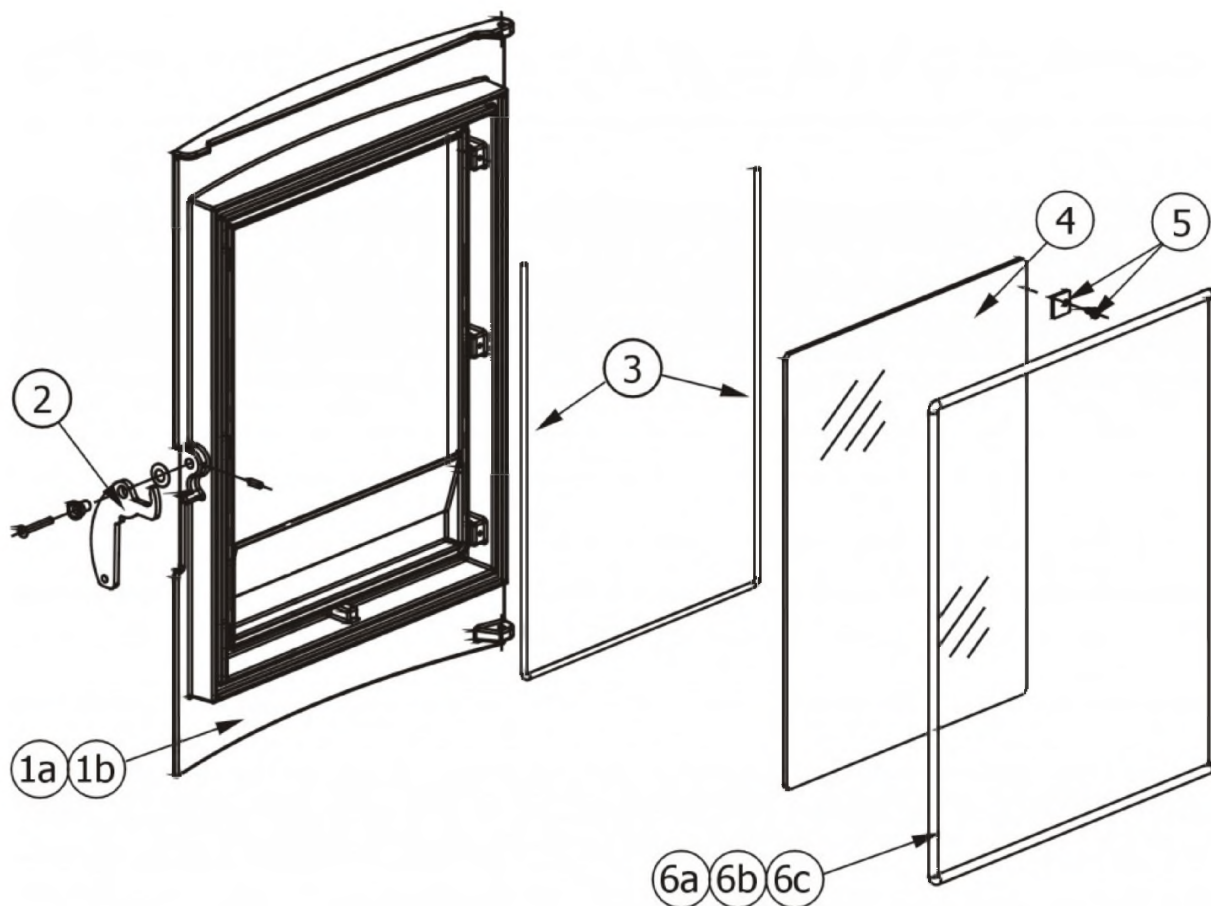

N°	Codice/Code	Descrizioni / Description / Beschreibung / Description / Descripción	Prezzo (€)
1a	4362024	Porta completa / Complete door / Komplette Tür / Porte complète / Puerta completa	358.00
1b	43620240	Telaio porta in ghisa / Cast iron door frame / Türrahmen aus Gusseisen / Cadre porte en fonte / Armazón puerta en arrabio	138.00
2	43620212	Maniglia completa / Complete handle / Kompletter Griff / Poignée complète / Tirador completo	27.00
3	4120106	Guarnizione a nastro fireglass / Fireglass tape gasket / Banddichtung Fireglass / Joint ruban Fireglass / Guarnición a cinta Fireglass	28.00
4	4170169	Vetroceramico completo di guarnizione / Glass with gasket / Glaskeramikscheibe mit Dichtung / Vitrocéramique avec joint / Cristal cerámico con guarnición	127.00
5	43620241A	Staffe di fissaggio vetroceramico / Glass fastening brackets / Befestigungsbügel Glaskeramikscheibe / Étrier de fixation vitrocéramique / Abrazaderas de fijación cristal cerámico	20.00
6a	4120103A	Cordino fibrocaramico Ø 10 mm (5 mt.) / Ceramic fibre cord Ø 10 mm (5 m) / Keramikfaserschnur Ø 10 mm (5 m) / Cordon en fibre céramique Ø 10 mm (5 m) / Junta a cuerda de fibra cerámica Ø 10 mm (5 m)	29.00
6b	4120103B	Cordino fibrocaramico Ø 10 mm (50 mt.) / Ceramic fibre cord Ø 10 mm (50 m) / Keramikfaserschnur Ø 10 mm (50 m) / Cordon en fibre céramique Ø 10 mm (50 m) / Junta a cuerda de fibra cerámica Ø 10 mm (50 m)	167.00
6c	41201031	Kit sostituzione cordino (cordino+silicone) Ø 10 mm / Cord replacement kit (cord + silicon) Ø 10 mm / Schnuraustauschsatz (Schnur+Silikon) Ø 10 mm / Kit remplacement cordon (cordon + silicone) Ø 10 mm / Kit sustitución junta a cuerda (junta a cuerda+silicón) Ø 10 mm	43.00

MCZ GROUP

POLAR HYDRO

Rivestimenti in ceramica / Ceramic claddings / Keramikverkleidungen / Habillages en céramique /
Revestimientos de cerámica

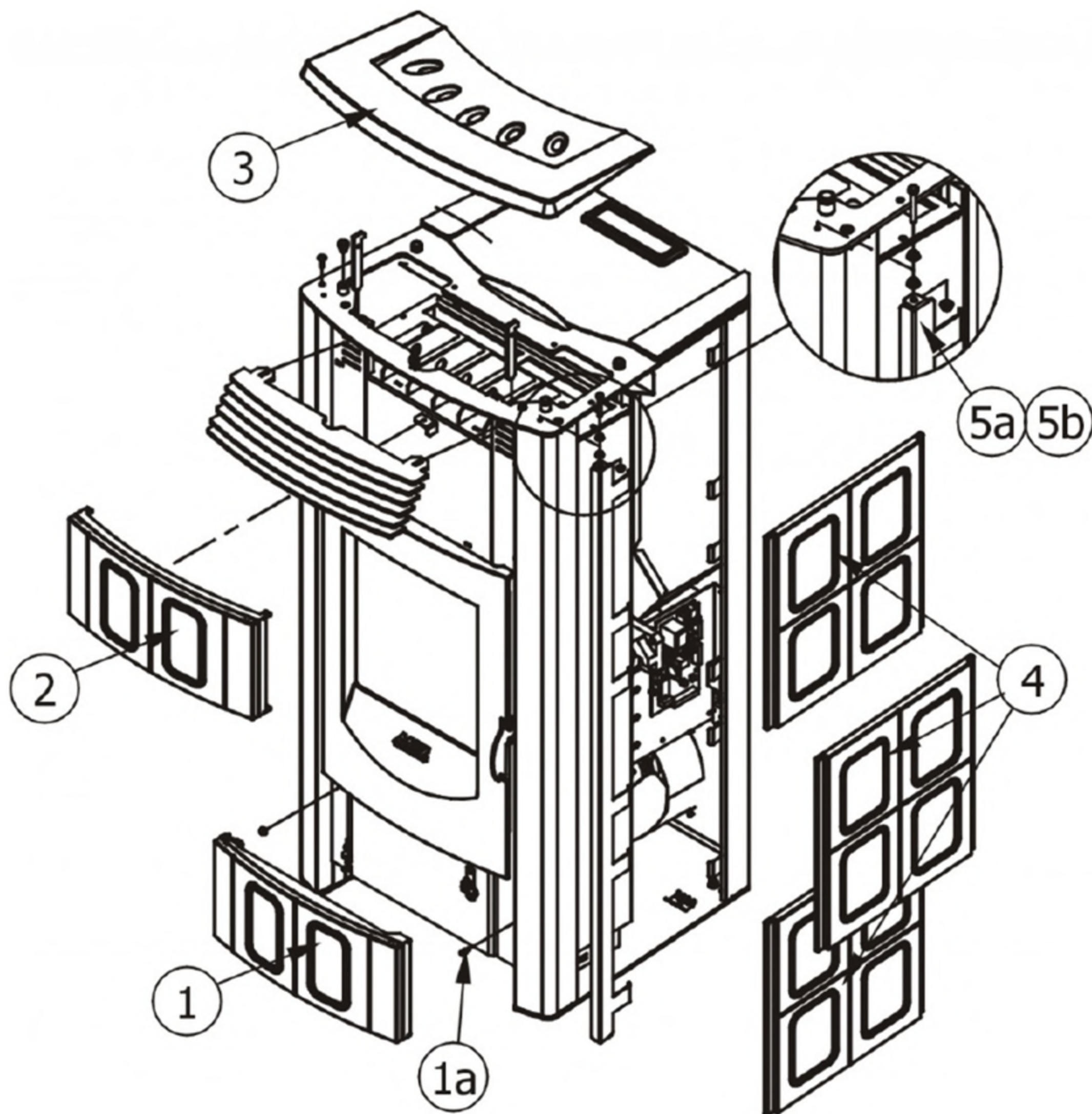

POLAR HYDRO

Rivestimenti in ceramica / Ceramic claddings / Keramikverkleidungen / Habillages en céramique / Revestimientos de cerámica

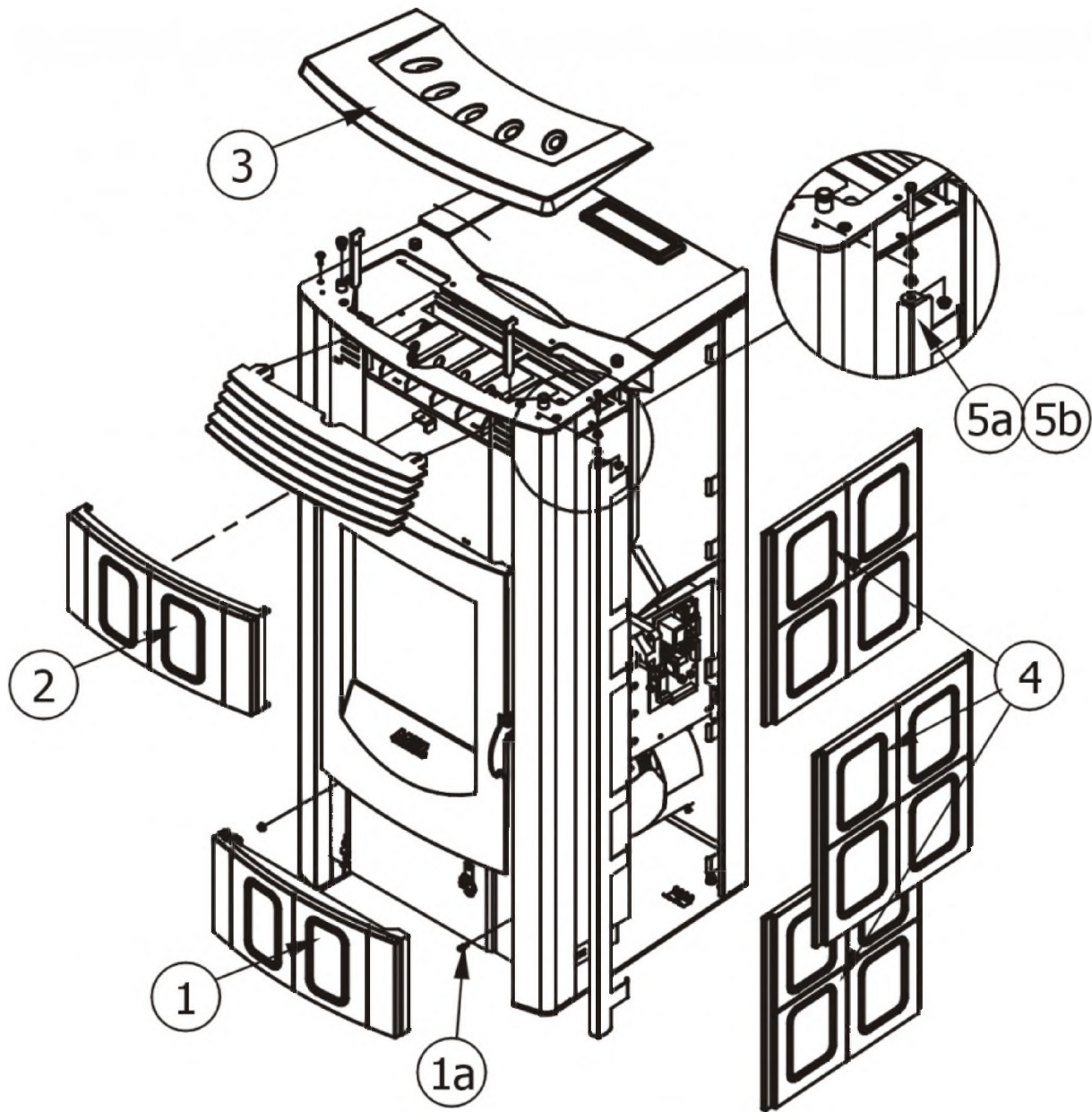

N°	Codice/Code	Descrizioni / Description / Beschreibung / Description / Descripción	Prezzo (€)
1	43671151	Sportello ceramica Polar bordeaux / Polar burgundy ceramic door / Keramikklappe Polar Bordeaux / Porte céramique Polar bordeaux / Puerta cerámica Polar burdeos	135.00
1	43671161	Sportello ceramica Polar desert / Polar desert ceramic door / Keramikklappe Polar Desert / Porte céramique Polar désert / Puerta cerámica Polar desierto	128.00
1	43671171	Sportello ceramica Polar Sale e Pepe / Polar salt and pepper ceramic door / Keramikklappe Polar Salz and Pfeffer / Porte céramique Polar poivre-et-sel / Puerta cerámica Polar sal y pimienta	86.00
1	43671221	Sportello ceramica Polar sabbia / Polar sand ceramic door / Keramikklappe Polar Sand / Porte céramique Polar sable / Puerta cerámica Polar arena	89.00
1a	4120796	Ricettacolo con perno / Bracket / Haltebügel / Étrier / Abrazadera	19.00
2	43671151	Sportello ceramica Polar bordeaux / Polar burgundy ceramic door / Keramikklappe Polar Bordeaux / Porte céramique Polar bordeaux / Puerta cerámica Polar burdeos	135.00
2	43671161	Sportello ceramica Polar desert / Polar desert ceramic door / Keramikklappe Polar Desert / Porte céramique Polar désert / Puerta cerámica Polar desierto	128.00

2	43671171	Sportello ceramica Polar Sale e Pepe / Polar salt and pepper ceramic door / Keramikklappe Polar Salz and Pfeffer / Porte céramique Polar poivre-et-sel / Puerta cerámica Polar sal y pimienta	86.00
2	43671221	Sportello ceramica Polar sabbia / Polar sand ceramic door / Keramikklappe Polar Sand / Porte céramique Polar sable / Puerta cerámica Polar arena	89.00
3	4125236	Top in ceramica bordeaux / Burgundy ceramic top / Keramikabdeckplatte Bordeaux / Dessus en céramique bordeaux / Top en cerámica burdeos	88.00
3	4125237	Top in ceramica sabbia / Sand majolica top / Keramikabdeckplatte Sand / Dessus en céramique sable / Top en cerámica arena	87.00
3	4125263	Top in ceramica desert / Desert ceramic top / Keramikabdeckplatte Desert / Dessus en céramique désert / Top en cerámica desierto	88.00
3	4125264	Top in ceramica sale e pepe / Salt and pepper ceramic top / Keramikabdeckplatte Salz und Pfeffer / Dessus en céramique poivre et sel / Top en cerámica sal y pimenta	96.00
4	4125239	Ceramiche laterali Polar bordeaux / Polar burgundy side ceramics / Seitliche Keramik Polar Bordeaux / Carreaux latéraux en céramique Polar bordeaux / Cerámicas laterales Polar burdeos	64.00
4	4125240	Ceramiche laterali Polar sabbia / Polar sand side ceramics / Seitliche Keramik Polar Sand / Carreaux latéraux en céramique Polar sable / Cerámicas laterales Polar arena	64.00
4	4125265	Ceramiche laterali Polar desert / Polar desert side ceramics / Seitliche Keramik Polar Desert / Carreaux latéraux en céramique Polar désert / Cerámicas laterales Polar desierto	80.00
4	4125266	Ceramiche laterali Polar sale e pepe / Polar salt and pepper side ceramics / Seitliche Keramik Polar Salz und Pfeffer / Carreaux latéraux en céramique Polar poivre et sel / Cerámicas laterales Polar sal y pimenta	64.00
5a	43640490B	Asta blocco ceramiche DX / R. ceramics blocking rod / Re. Befestigungsbügel der Keramik / Tige blocage carreaux en céramique D. / Asta bloqueo cerámicas DCHA	39.00
5b	43640490C	Asta blocco ceramiche SX / L. ceramics blocking rod / Li. Befestigungsbügel der Keramik / Tige blocage carreaux en céramique G. / Asta bloqueo cerámicas IZDA	35.00

MCZ GROUP

POLAR HYDRO

Componenti interni / Internal components / Interne Bauteile / Composants internes / Componentes internos

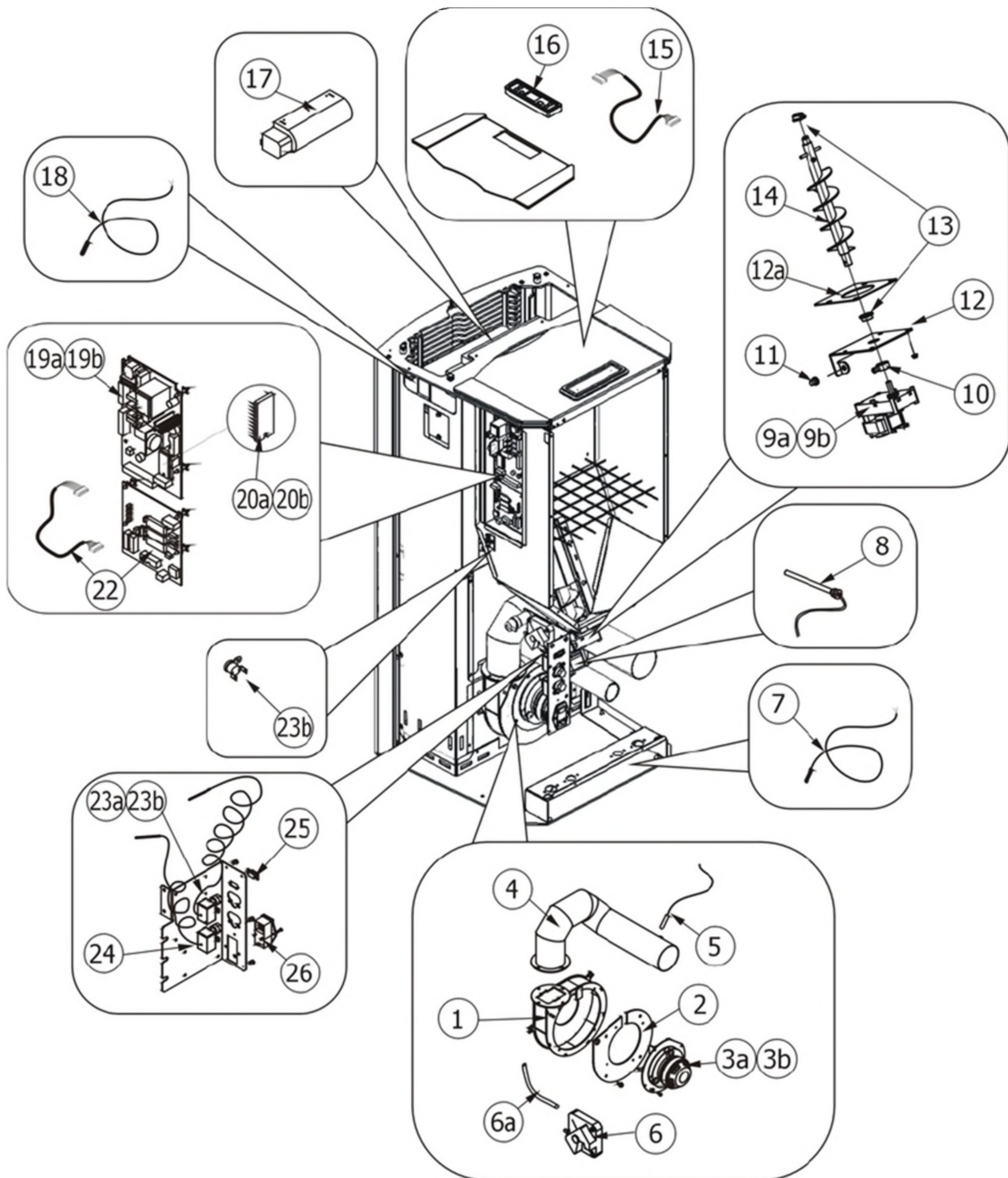

POLAR HYDRO

Componenti interni / Internal components / Interne Bauteile / Composants internes / Componentes internos

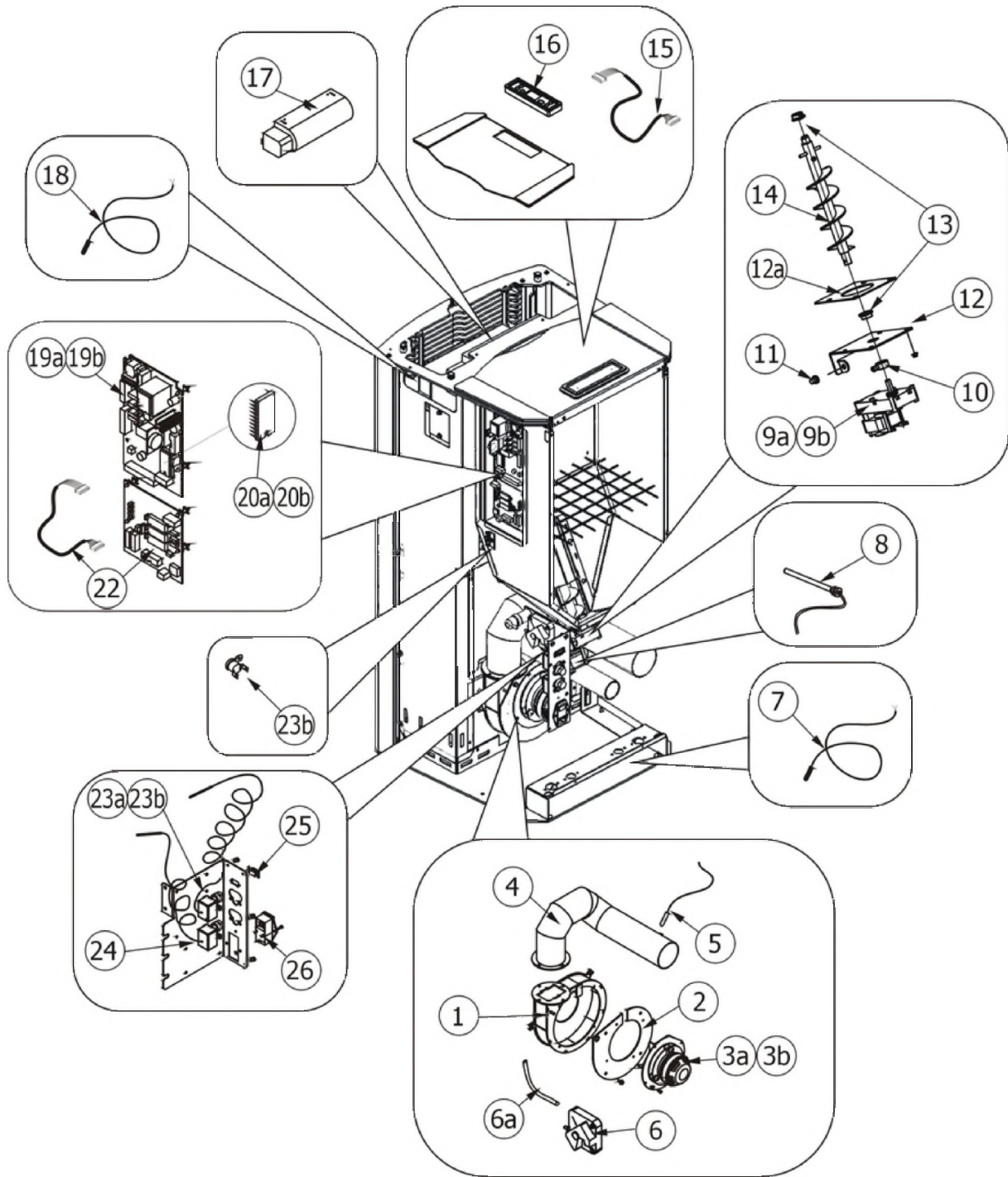

N°	Codice/Code	Descrizioni / Description / Beschreibung / Description / Descripcion	Prezzo (€)
1	41801301500	Guarnizione ventilatore fumi / Smoke exhaust fan gasket / Dichtung Rauchabsauggebläse / Joint Ventilateur aspiration fumées / Junta ventilador aspiracion humos	20.00
1	43640672	Voluta per ventilatore con encoder / Volute for fan with encoder / Volute für Gebläse mit Encoder / Volute pour ventilateur avec encoder / Voluta para ventilador con encoder	97.00
2	43640676	Kit adattatore ventilatore fumi con encoder su voluta per ventilatore senza encoder / Smoke exhaust fan with encoder adaptor kit up on volute for fan without encoder / Adaptersatz Rauchgebläse mit Encoder auf der Volute für Gebläse ohne Encoder / Kit adaptateur ventilateur fumées avec encoder sur volute pour ventilateur sans encoder / Kit adaptador ventilador humos con encoder en voluta para ventilador sin encoder	46.00

3a	4160348	Ventilatore aspirazione fumi SENZA microprocessore / Smoke exhaust fan WITHOUT microproc essor / Rauchabsauggebläse OHNE Microprozes sor / Ventilateur aspiration fumées SANS microprocesseur / Ventilador aspiración de humos SIN microprocesador	-
3b	414508016	Ventilatore aspirazione fumi con encoder / Smoke exhaust fan WITH encoder / Rauchabsauggebläse MIT Encoder / Ventilateur aspiration fumées AVEC encoder / Ventilador aspiración humos con codificador	282.00
4	43640641	Tubo uscita fumi / Smoke outlet pipe / Rohr Rauchabzug / Tuyau sortie fumées / Tubo salida humos	104.00
5	4160239	Sonda temperatura fumi / Smoke temperature sensor / Rauchtemperaturfühler / Sonde température fumées / Sonda temperatura humos	27.00
6	414508040	Pressostato 1.2 mbar / Pressure switch 1.2 mbar / Druckwächter 1.2 mbar / Pressostat 1.2 mbar / Presostato 1.2 mbar	41.00
6a	4120631A	Tubicino siliconico - 5m / Silicon tube - 5m / Silikonrohr - 5m / Petit tuyau en silicone - 5m / Tubo silicónico - 5m	22.00
7	4160386	Sonda temperatura ambiente/acqua / Room/Water temperature sensor / Raum- Wassertemperaturfühler / Sonde température ambiance/eau / Sonda temperatura ambiente/agua	21.00
8	41450902600	Candeletta accensione pellet / Pellet ignition sparkplug / Zündkerze Pelletzündung / Bougie d'allumage pellet / Bujía encendido pellet	45.00
8	41801599450	Kit 50 candelette / 50 Sparkplugs Kit / Bausatz 50 Zündkerzen / Kit 50 Bougies / Kit 50 Bujías	1,800.00
9a	4160310	Motoriduttore 3,85 RPM MERKLE KORFF / Reduction motor 3,85 RPM MERKLE KORFF / Motoriduttore 3,85 RPM MERKLE KORFF / Motoreducteur 3,85 RPM MERKLE KORFF / Motoriduttore 3,85 RPM MERKLE KORFF	-
9b	41450901600	Motoriduttore 3,3 rpm Merkle Korff / Reduction motor 3,3 rpm Merkle Korff / Getriebemotor 3,3 RPM MERKLE KORFF / Motoréducteur 3,3 RPM MERKLE KORFF / Motorreductor 3,3 rpm Merkle Korff	95.00
10	4120896	Connettore motoriduttore-coclea / Reduction motor-feed screw connector / Verbindung Getriebemotor-Schnecke / Connecteur motoréducteur-vis sans fin / Conector motorreductor-cóclea	20.00
11	4120180	Gommini paracolpi (4 pz) / Rubber bumpers (4 pcs.) / Schlagschutzgummi (4 Stck) / Pièces caoutchouc antichoc (4 pcs) / Cauchitos anti-golpes (4 pz)	21.00
12	43640584	Base della coclea / Feed screw base / Untergestell der Förderschnecke / Base de la vis sans fin / Base de la còclea	49.00
12a	4120615	Guarnizione base della coclea / Feed screw base gasket / Dichtung Untergestell der Förderschnecke / Joint pour la base de la vis sans fin / Junta base de la còclea	19.00
13	4120614	Boccola grafitata (2 pz) / Etched bush (2 pcs) / Graphitbuchse (2 Stck) / Bride graphitée (2 pcs) / Brida grafitada (2 pz)	20.00
14	43640440	Albero coclea - Motoriduttore 3,5 rpm / Feed screw shaft - Reduction motor 3,5 RPM / Schnecke - Getriebemotor 3,5 RPM / Vis sans fin - Motoréducteur 3,5 RPM / Còclea - Motorreductor 3,5 RPM	54.00
15	4160414	Cavo Rond-Flat / Round-Flat cable / Round-Flat Kabel / Rond-Flat Câble / Cable Rond-Flat	22.00
16	4160311	Pannello comandi con display a LED / Control panel with LED display / Bedienblende mit LED Display / Tableau de commande avec afficheur à LED / Panel de mandos con pantalla LED	70.00
17	4160473	Ventilatore aria / Air fan / Luftgebläse / Ventilateur air / Ventilador aire	62.00
18	4160386	Sonda temperatura ambiente/acqua / Room/Water temperature sensor / Raum- Wassertemperaturfühler / Sonde température ambiance/eau / Sonda temperatura ambiente/agua	21.00
19a	4160312	Scheda madre per ventilatore fumi senza encoder / Motherboard for smoke exhaust fan without encoder / Hauptplatine für Rauchgebläse OHNE Encoder / Carte mère pour ventilateur fumées SANS encoder / Tarjeta madre para ventilador de humos SIN microprocesador	203.00
19b	4160480B	Scheda madre per ventilatore fumi con microprocessore e motoriduttore 3,3 rpm Merkle Korff / Motherboard for smoke exhaust fan WITH microprocessor - Reduction moto or 3,3 RPM MERKLE KORFF / Hauptplatine für Rauchgebläse MIT Mircoprozesor - Getriebemotor 3,3 R RPM MERKLE KORFF / Carte mère pour ventilateur fumées AVEC microprocesseur - Motoréducteu ur 3,3 RPM MERKLE KORFF / Tarjeta madre para ventilador de humos CON microprocesor - Motorreductor tor 3,3 RPM MERKLE KORFF	136.00
20a	4160401A	Microprocessore ver.Z3 per motoriduttore MERKLE KORFF 3,3 RPM / Microprocessor ver.Z3 for Merkle Korff 3.3 rpm reduction motor / Mikroprozessor ver.Z3 für Getriebemotor MERKLE KORFF 3,3 U/Min / Microprocesseur version Z3 pour motoréducteur MERKLE KORFF 3,3 tours/mn / Microprocesador ver. Z3 para motorreductor MERKLE KORFF 3.3 RPM	37.00
20b	4160312A	Microprocessore ver.ZM per motoriduttore Merkle Korff 3,3 rpm / Microprocessor ver.ZM for Merkle Korff 3.3 rpm reduction motor / Mikroprozessor ver.ZM für Getriebemotor MERKLE KORFF 3,3 U/Min / Microprocesseur version ZM pour motoréducteur MERKLE KORFF 3,3 tours/mn / Microprocesador ver. ZM para motorreductor MERKLE KORFF 3.3 RPM	34.00
22	4160354	Scheda utilizzi (solo per versione Hydro/ACS) + Cavo "flat" collegamento scheda utilizzi-scheda madre / users board (only for Hydro/ACS version) + "Flat" cable connection users-motherboard / Betriebsplatine (nur für Modell Hydro/ACS) + Flat Kabel Verbindung Betriebs- Hauptplatine / carte emplois (pour version po/no Hydro/ACS) + Câble "flat" branchement carte emplois-carte mère / Tarjeta utilizos (solo para versión Hydro/ACS)+ Cable "flat" conexión tarjeta usos-tarjeta madre	67.00
23a	414508027	Termostato a bulbo H2O 90°C / Bulb thermostat H2O 90°C / Kugelthermostat H2O 90°C / Thermostat à bulbe H2O 90°C / Termostato de bulbo H2O 90°C	37.00
23b	412007004	Clickson 110°C / Clickson 110°C / Clickson 110°C / Clickson 110°C / Clickson 110°C	20.00
23b	412007004	Clickson 110°C / Clickson 110°C / Clickson 110°C / Clickson 110°C / Clickson 110°C	20.00

24	414508027	Termostato a bulbo H2O 90°C / Bulb thermostat H2O 90°C / Kugelthermostat H2O 90°C / Thermostat à bulbe H2O 90°C / Termostato de bulbo H2O 90°C	37.00
25	4160244	Connettore seriale con cavo di collegamento / Serial connector with connection cable / Serielle Verbindung mit Verbindungskabel / Connecteur sériel avec cable de connection / Conector serial con cable de conexión	22.00
26	4160193	Pulsante accensione / On/Off button / Zündungstaste / Touche d'allumage / Botón encendido	28.00

MCZ GROUP

POLAR HYDRO

Componenti interni idraulici **SENZA** kit acqua sanitaria / Internal plumbing components **WITHOUT** domestic water kit / Interne hydraulische Bauteile **OHNE** Brauchwassersatz / Composants hydrauliques internes **SANS** kit eau sanitaire / Componentes internos hidráulicos **SIN** kit de agua sanitaria

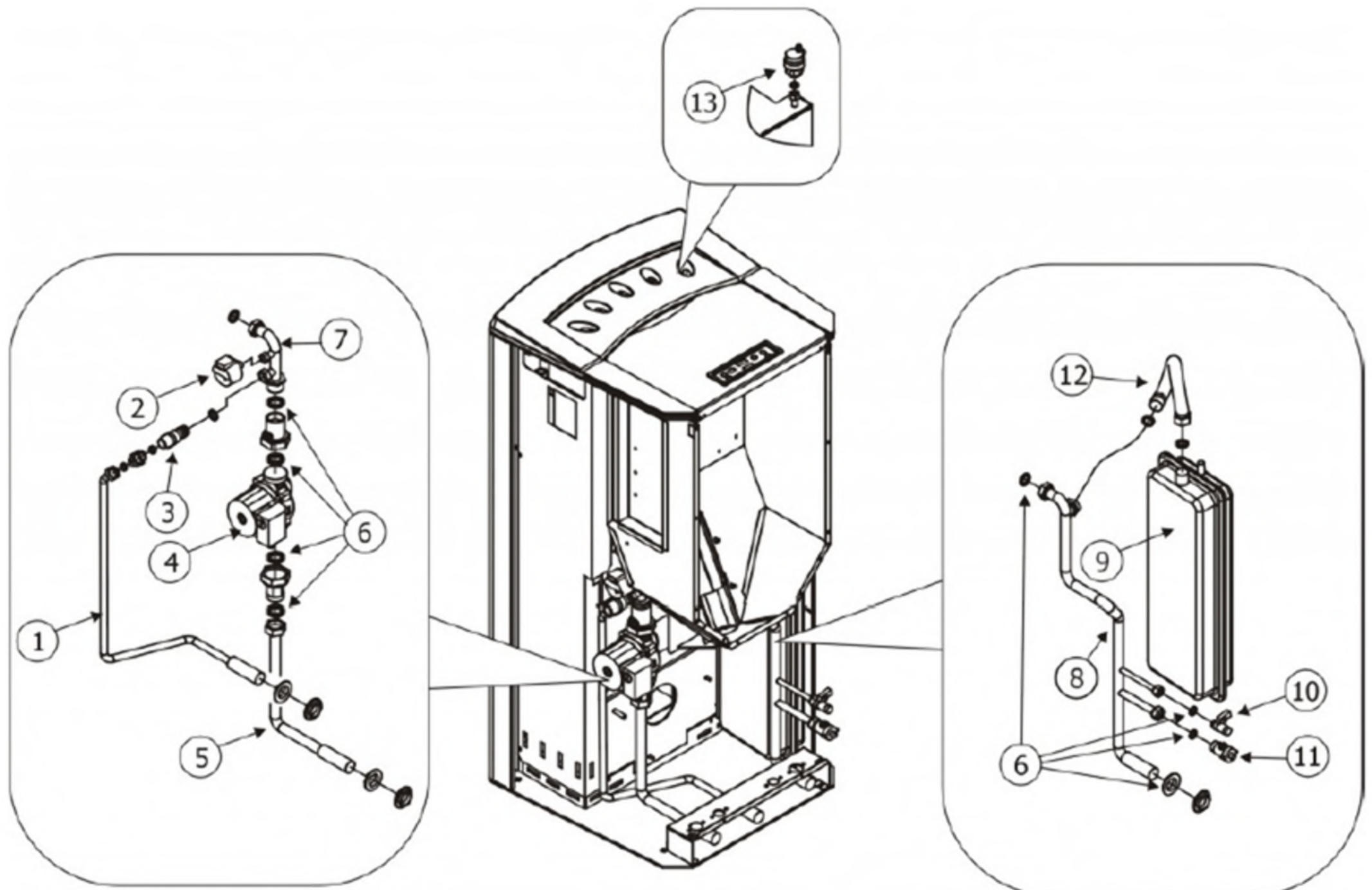

POLAR HYDRO

Componenti interni idraulici **SENZA** kit acqua sanitaria / Internal plumbing components **WITHOUT** domestic water kit / Interne hydraulische Bauteile **OHNE** Brauchwassersatz / Composants hydrauliques internes **SANS** kit eau sanitaire / Componentes internos hidráulicos **SIN** kit de agua sanitaria

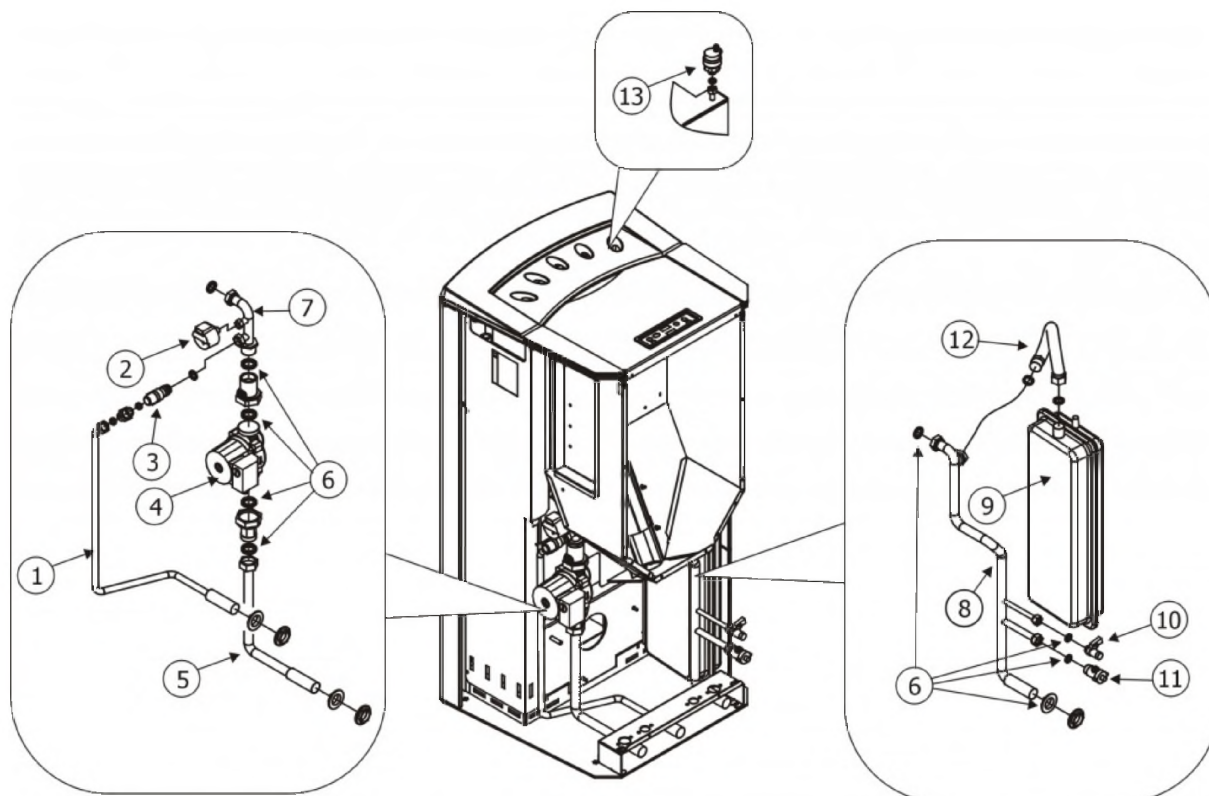

N°	Codice/Code	Descrizioni / Description / Beschreibung / Description / Descripción	Prezzo (€)
1	4160324	Tubo di scarico 3 bar (sfiato) / Drain tube 3 bar (vent) / Druckablassrohr 3 Bar (Entlüftung) / Tuyau d'évacuation 3 bar (dégagement) / Tubo de desagüe 3 bar (purgado)	47.00
2	41451800100	Trasduttore di pressione / Pressure transducer / Druckwächter / Transducteur de pression / Transductor de presión	55.00
3	4120778	Valvola di massima pressione (3 bar) / Maximum pressure valve (3 bar) / Hochdruckventil (3 Bar) / Soupape de pression maximale (3 bar) / Válvula de máxima presión (3 bar)	31.00
4	41501205200	Pompa di circolazione acqua / Water circulation pump / Umwälzpumpe / Pompe de circulation eau / Bomba circulación agua	-
4	41501500100	Pompa alta efficienza / High efficiency pump / Hoch effizientz Pumpe / Pompe de circulation haut rendement / Bomba circulación alto rendimiento	218.00
5	4160355	Tubo di mandata acqua da caldaia / Boiler water delivery tube / Vorlaufrohr Wasser vom Kessel / Tuyau de refoulement eau de la chaudière / Tubo de envío de agua de la caldera	-
6	41207910	Kit guarnizioni impianto idraulico / Hydraulic system gasket kit / Dichtungsbausatz für Hydraulikanlage / Kit de joints pour l'installation hydraulique / Kit de juntas de la instalación de fontanería	26.00
7	4160328	Tubo di mandata acqua da caldaia / Boiler water delivery tube / Vorlaufrohr Wasser vom Kessel / Tuyau de refoulement eau de la chaudière / Tubo de envío de agua de la caldera	-
8	4160356	Tubo di ritorno acqua in caldaia / Boiler water return tube / Rücklaufrohr Wasser zum Kessel / Tuyau retour eau dans la chaudière / Tubo de regreso de agua a la caldera	60.00
9	4120775	Vaso espansione (6 l) / Expansion vessel (6 l) / Expansionsgefäß (6 l) / Vase d'expansion (6 l) / Vaso de expansion (6 l)	75.00
10	4160352	Valvola a sfera con ritegno ½" / ½" ball valve with retainer / Kugelrückschlagventil ½" / Soupape à bille avec retenue ½" / Válvula esférica con retención ½"	39.00
11	4160351	Rubinetto scarico ½" con tappo / ½" drain valve with plug / Ablaufhahn ½" mit Stopfen / Robinet évacuation ½" avec bouchon / Grifo de desagüe ½" con tapón	31.00
12	4120781	Giunto estensibile inox ¾" / ¾" stainless steel flexible joint / Edelstahl Verbindungsschlauch ¾" / Joint flexible inox ¾" / junta flexible inox ¾"	48.00
13	4120779	Valvola di sfiato / Vent valve / Entlüftungsventil / Soupape de dégagement / Válvula respiradero	26.00

MCZ GROUP

POLAR HYDRO

Componenti interni idraulici CON kit acqua sanitaria fino al 12-2007 / Componenti interni idraulici CON kit acqua sanitaria fino al 12-2007 / Interne hydraulische Ersatzteile MIT Wasserbrauchsatz bis 12-2007 / Componenti interni idraulici CON kit acqua sanitaria fino al 12-2007 / Piezas internas hydraulicas CON kit agua sanitaria hasta el 12-2007

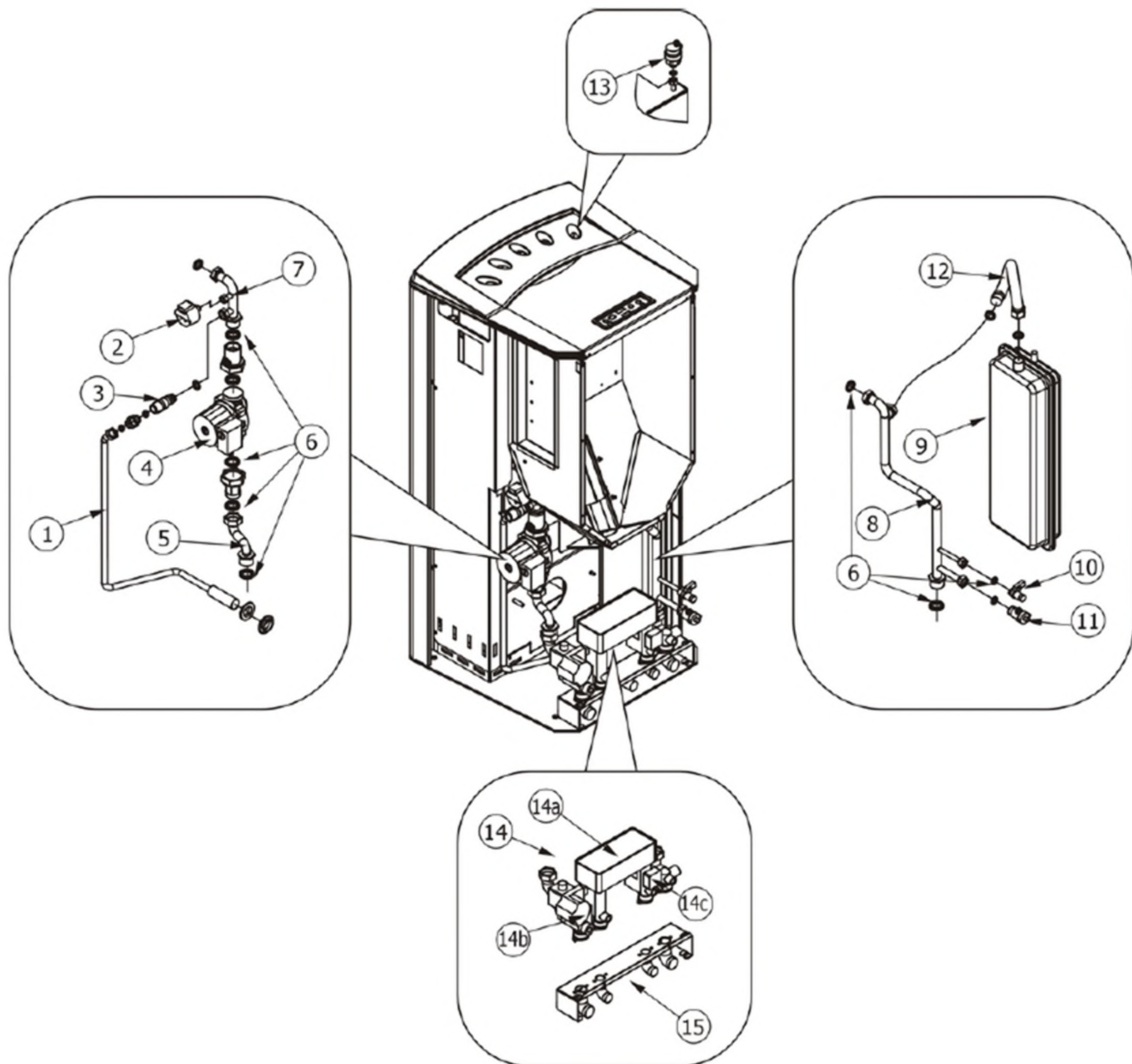

POLAR HYDRO

Componenti interni idraulici CON kit acqua sanitaria fino al 12-2007 / Componenti interni idraulici CON kit acqua sanitaria fino al 12-2007 / Interne hydraulische Ersatzteile MIT Wasserbrauchsatz bis 12-2007 / Componenti interni idraulici CON kit acqua sanitaria fino al 12-2007 / Piezas internas hydrulicas CON kit agua sanitaria hasta el 12-2007

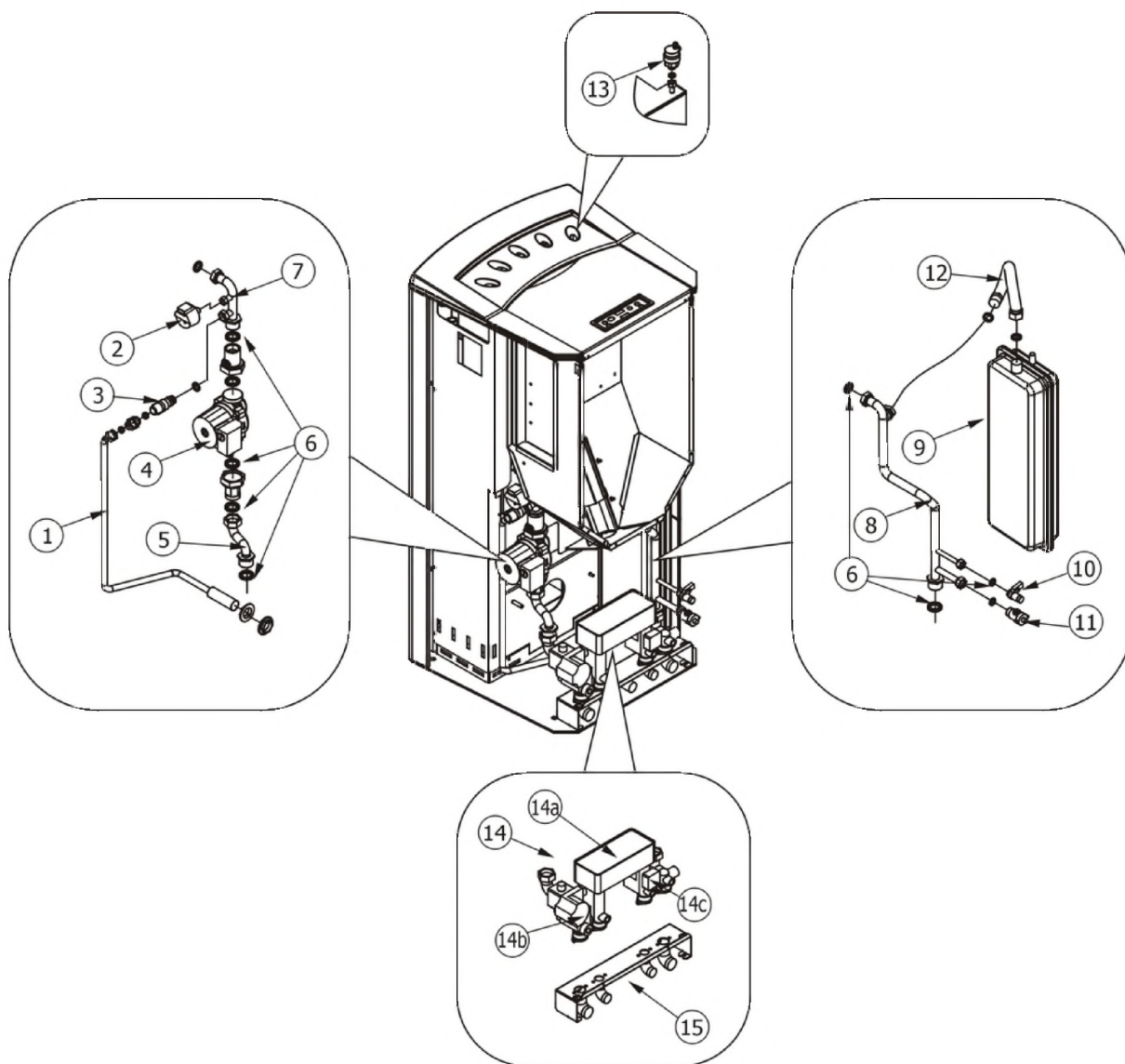

N°	Codice/Code	Descrizioni / Description / Beschreibung / Description / Description	Prezzo (€)
1	4160324	Tubo di scarico 3 bar (sfiato) / Drain tube 3 bar (vent) / Druckablassrohr 3 Bar (Entlüftung) / Tuyau d'évacuation 3 bar (dégagement) / Tubo de desague 3 bar (purgado)	47.00
2	41451800100	Trasduttore di pressione / Pressure transducer / Druckwächter / Transducteur de pression / Transductor de presión	55.00
3	4120778	Valvola di massima pressione (3 bar) / Maximum pressure valve (3 bar) / Hochdruckventil (3 Bar) / Soupape de pression maximale (3 bar) / Válvula de máxima presión (3 bar)	31.00
4	41501205200	Pompa di circolazione acqua / Water circulation pump / Umwälzpumpe / Pompe de circulation eau / Bomba circulación agua	-
4	41501500100	Pompa alta efficienza / High efficiency pump / Hoch effizientz Pumpe / Pompe de circulation haut rendement / Bomba circulación alto rendimiento	218.00
5	4160357	Tubo di mandata acqua da caldaia / Boiler water delivery tube / Vorlaufrohr Wasser vom Kessel / Tuyau de refoulement eau de la chaudière / Tubo de envío de agua de la caldera	47.00
6	41207910	Kit guarnizioni impianto idraulico / Hydraulic system gasket kit / Dichtungsbausatz für Hydraulikanlage / Kit de joints pour l'installation hydraulique / Kit de juntas de la instalación de fontanería	26.00
6	41207910	Kit guarnizioni impianto idraulico / Hydraulic system gasket kit / Dichtungsbausatz für Hydraulikanlage / Kit de joints pour l'installation hydraulique / Kit de juntas de la instalación de fontanería	26.00

7	4160328	Tubo di mandata acqua da caldaia / Boiler water delivery tube / Vorlaufrohr Wasser vom Kessel / Tuyau de refoulement eau de la chaudière / Tubo de envío de agua de la caldera	-
8	4160318	Tubo di ritorno acqua in caldaia / Boiler water return tube / Rücklaufrohr Wasser zum Kessel / Tuyau retour eau dans la chaudière / Tubo de regreso de agua a la caldera	57.00
9	4120775	Vaso espansione (6 l) / Expansion vessel (6 l) / Expansionsgefäß (6 l) / Vase d'expansion (6 l) / Vaso de expansión (6 l)	75.00
10	4160352	Valvola a sfera con ritegno ½" / ½" ball valve with retainer / Kugelrückschlagventil ½" / Soupape à bille avec retenue ½" / Válvula esférica con retención ½"	39.00
11	4160351	Rubinetto scarico ½" con tappo / ½" drain valve with plug / Ablaufhahn ½" mit Stopfen / Robinet évacuation ½" avec bouchon / Grifo de desagüe ½" con tapón	31.00
12	4120781	Giunto estensibile inox ¾" / ¾" stainless steel flexible joint / Edelstahl Verbindungsschlauch ¾" / Joint flexible inox ¾" / junta flexible inox ¾"	48.00
13	4120779	Valvola di sfogo / Vent valve / Entlüftungsventil / Soupape de dégagement / Válvula respiradero	26.00
14	4160316	Kit completo produzione acqua sanitaria / Complete domestic water production kit / Bausatz Brauchwassererzeugung / Kit complet production d'eau sanitaire / Kit completo producción agua sanitaria	-
14a	4160317D	Scambiatore a piastre / Plate heat exchanger / Plattenwärmetauscher / Échangeur à plaques / Intercambiador a placas	-
14b	4160317E	Valvola deviatrice a 3 vie / 3-way deviator valve / 3-Wegeumleitventil / Soupape de déviation à 3 voies / Válvula desviadora de 3 vías	-
14c	4160317C	Flussostato / Air flow sensor / Flusswächter / Fluxostat / Flujostato	-
15	43640661A	Staffa di supporto kit acqua sanitaria / Domestic water kit support bracket / Haltebügel Brauchwassersatz / Étrier support kit eau sanitaire / Abrazadera de soporte kit agua sanitaria	62.00

MCZ GROUP

POLAR HYDRO

Componenti interni idraulici CON kit acqua sanitaria dal 01-2008 / Componenti interni idraulici CON kit acqua sanitaria dal 01-2008 / Interne hydraulische Ersatzteile MIT Wasserbrauchsatz seit 01-2008 / Componenti interni idraulici CON kit acqua sanitaria dal 01-2008 / Piezas internas hidráulicas CON kit agua sanitaria desde el 01-2008

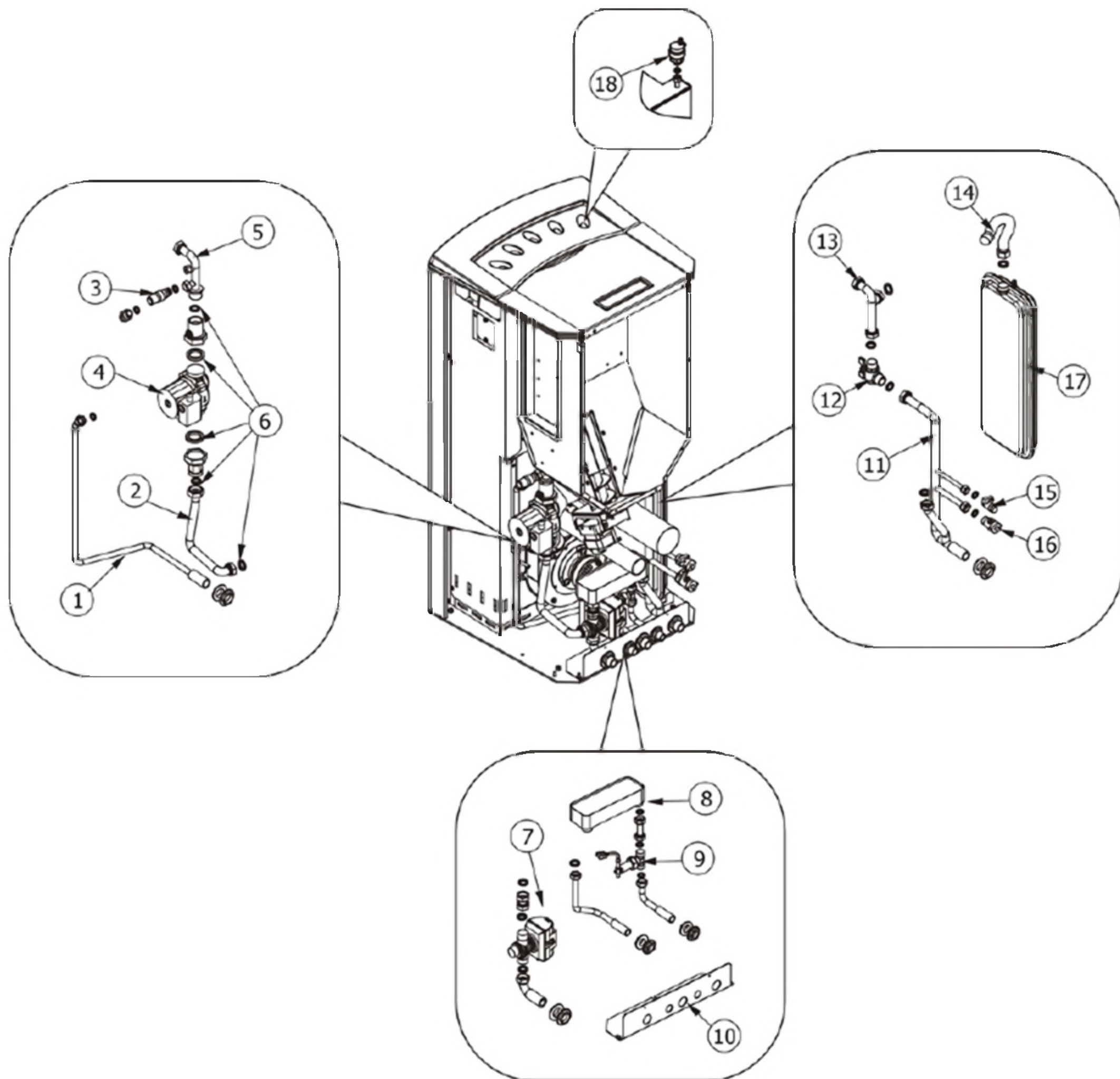

POLAR HYDRO

Componenti interni idraulici CON kit acqua sanitaria dal 01-2008 / Componenti interni idraulici CON kit acqua sanitaria dal 01-2008 / Interne hydraulische Ersatzteile MIT Wasserbrauchsatz seit 01-2008 / Componenti interni idraulici CON kit acqua sanitaria dal 01-2008 / Piezas internas hidráulicas CON kit agua sanitaria desde el 01-2008

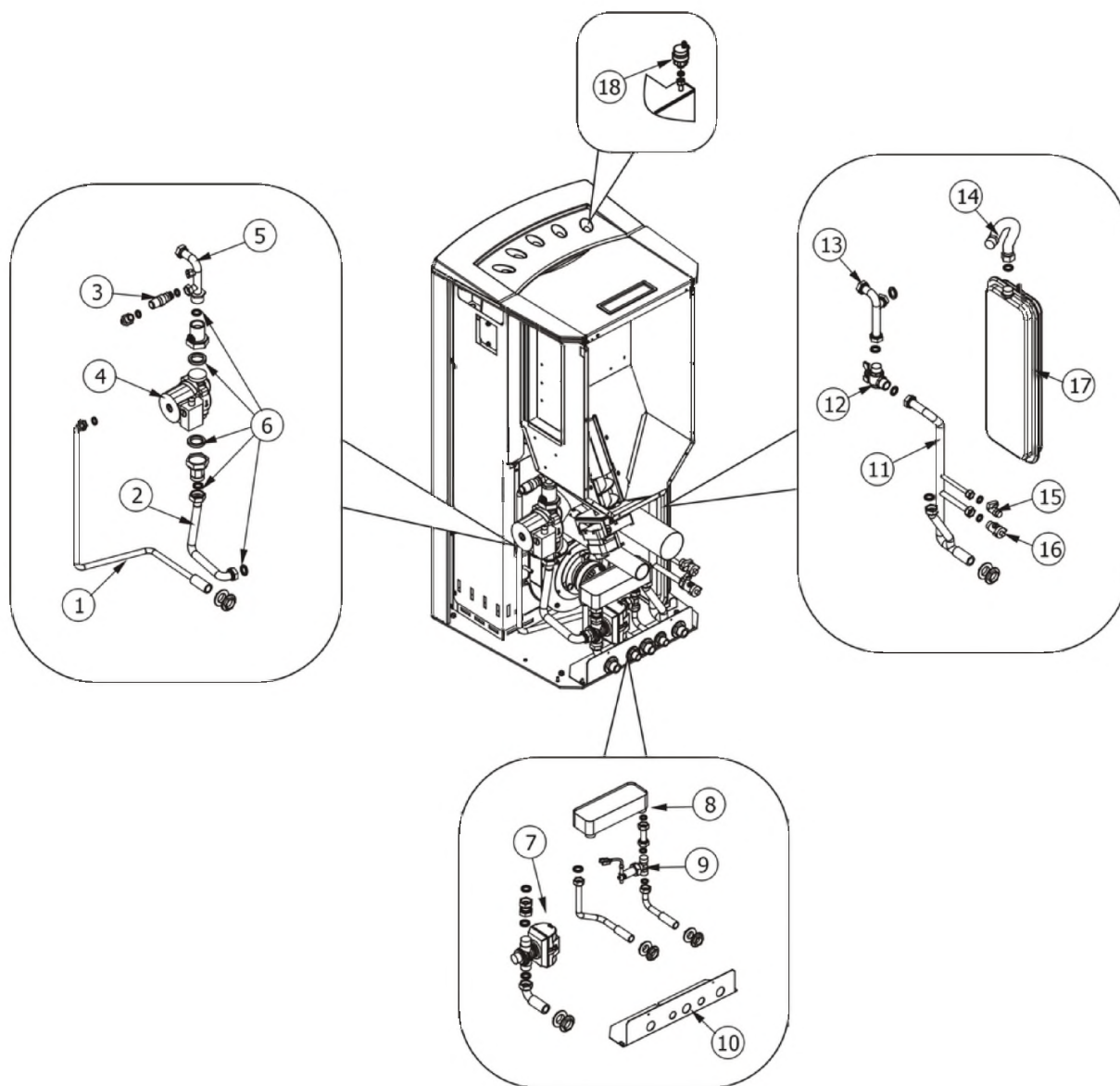

N°	Codice/Code	Descrizioni / Description / Beschreibung / Description / Descripción	Prezzo (€)
1	415008005	Tubo di scarico 3 bar (sfiato) / Drain tube 3 bar (vent) / Druckablassrohr 3 Bar (Entlüftung) / Tuyau d'évacuation 3 bar (dégagement) / Tubo de desagüe 3 bar (purgado)	33.00
2	415008011	Tubo di mandata acqua da caldaia / Boiler water delivery tube / Vorlaufrohr Wasser vom Kessel / Tuyau de refoulement eau de la chaudière / Tubo de envío de agua de la caldera	16.00
3	4120778	Valvola di massima pressione (3 bar) / Maximum pressure valve (3 bar) / Hochdruckventil (3 Bar) / Soupape de pression maximale (3 bar) / Válvula de máxima presión (3 bar)	31.00
4	41501205200	Pompa di circolazione acqua / Water circulation pump / Umwälzpumpe / Pompe de circulation eau / Bomba circulación agua	-
4	41501500100	Pompa alta efficienza / High efficiency pump / Hoch effizientz Pumpe / Pompe de circulation haut rendement / Bomba circulación alto rendimiento	218.00
5	4160328	Tubo di mandata acqua da caldaia / Boiler water delivery tube / Vorlaufrohr Wasser vom Kessel / Tuyau de refoulement eau de la chaudière / Tubo de envío de agua de la caldera	-
6	41207910	Kit guarnizioni impianto idraulico / Hydraulic system gasket kit / Dichtungsbausatz für Hydraulikanlage / Kit de joints pour l'installation hydraulique / Kit de juntas de la instalación de fontanería	26.00

6	41207910	Kit guarnizioni impianto idraulico / Hydraulic system gasket kit / Dichtungsbausatz für Hydraulikanlage / Kit de joints pour l'installation hydraulique / Kit de juntas de la instalación de fontanería	26.00
6	41207910	Kit guarnizioni impianto idraulico / Hydraulic system gasket kit / Dichtungsbausatz für Hydraulikanlage / Kit de joints pour l'installation hydraulique / Kit de juntas de la instalación de fontanería	26.00
6	41207910	Kit guarnizioni impianto idraulico / Hydraulic system gasket kit / Dichtungsbausatz für Hydraulikanlage / Kit de joints pour l'installation hydraulique / Kit de juntas de la instalación de fontanería	26.00
7	41501001600	Valvola deviatrice a 3 vie / 3-way deviator valve / 3-Wegeumleitventil / Soupape de déviation à 3 voies / Válvula desviadora de 3 vías	157.00
8	415008017	Scambiatore a piastra / Plate heat exchanger / Plattenwärmetauscher / Échangeur à plaques / Intercambiador de placas	120.00
9	415008018	Flussostat / Flow switch / Strömungswächter / Fluxostat / Flujostato	82.00
10	43641091A	Staffa di supporto kit acqua sanitaria / Domestic water kit support bracket / Haltebügel Brauchwassersatz / Étrier support kit eau sanitaire / Abrazadera de soporte kit agua sanitaria	21.00
11	415008015	Tubo di ritorno acqua in caldaia / Boiler water return tube / Rücklaufrohr Wasser zum Kessel / Tuyau retour eau dans la chaudière / Tubo de regreso de agua a la caldera	75.00
12	415007001	Rubinetto 3/4" / 3/4" valve / Ablaufhahn 3/4" / Robinet 3/4" / Grifo 3/4"	35.00
13	415008006	Tubo superiore di ritorno acqua in caldaia / Upper boiler water return tube / Oberes Rücklaufrohr Wasser zum Kessel / Tuyau supérieur retour eau dans la chaudière / Tubo superior de regreso de agua a la caldera	28.00
14	4120781	Giunto estensibile inox 3/4" / 3/4" stainless steel flexible joint / Edelstahl Verbindungsschlauch 3/4" / Joint flexible inox 3/4" / junta flexible inox 3/4"	48.00
15	4160352	Valvola a sfera con ritegno 1/2" / 1/2" ball valve with retainer / Kugelrückschlagventil 1/2" / Soupape à bille avec retenue 1/2" / Válvula esférica con retención 1/2"	39.00
16	4160351	Rubinetto scarico 1/2" con tappo / 1/2" drain valve with plug / Ablaufhahn 1/2" mit Stopfen / Robinet évacuation 1/2" avec bouchon / Grifo de desagüe 1/2" con tapon	31.00
17	4120775	Vaso espansione (6 l) / Expansion vessel (6 l) / Expansionsgefäß (6 l) / Vase d'expansion (6 l) / Vaso de expansión (6 l)	75.00
18	4120779	Valvola di sfiato / Vent valve / Entlüftungsventil / Soupape de dégagement / Válvula respiradero	26.00
19	4160327	Valvola minipomp a sfera / Connection delivery tube circ.pump / Verbindungsrohr vorlaufrohr-pumpe / Connexion tuyau refoulement-pompe / Conexión tubo envío agua-bomba	66.00
20	4160325	Valvola unidirezionale / Unidirectional valve / Einrichtungsventil / Soupape unidirectionnelle / Válvula unidireccional	-