

MCZ GROUP

KLIN

Componenti Struttura Esterna / External structure components / Bauteile Aussenkorpus / Composants structure externe / Componentes estructura externa

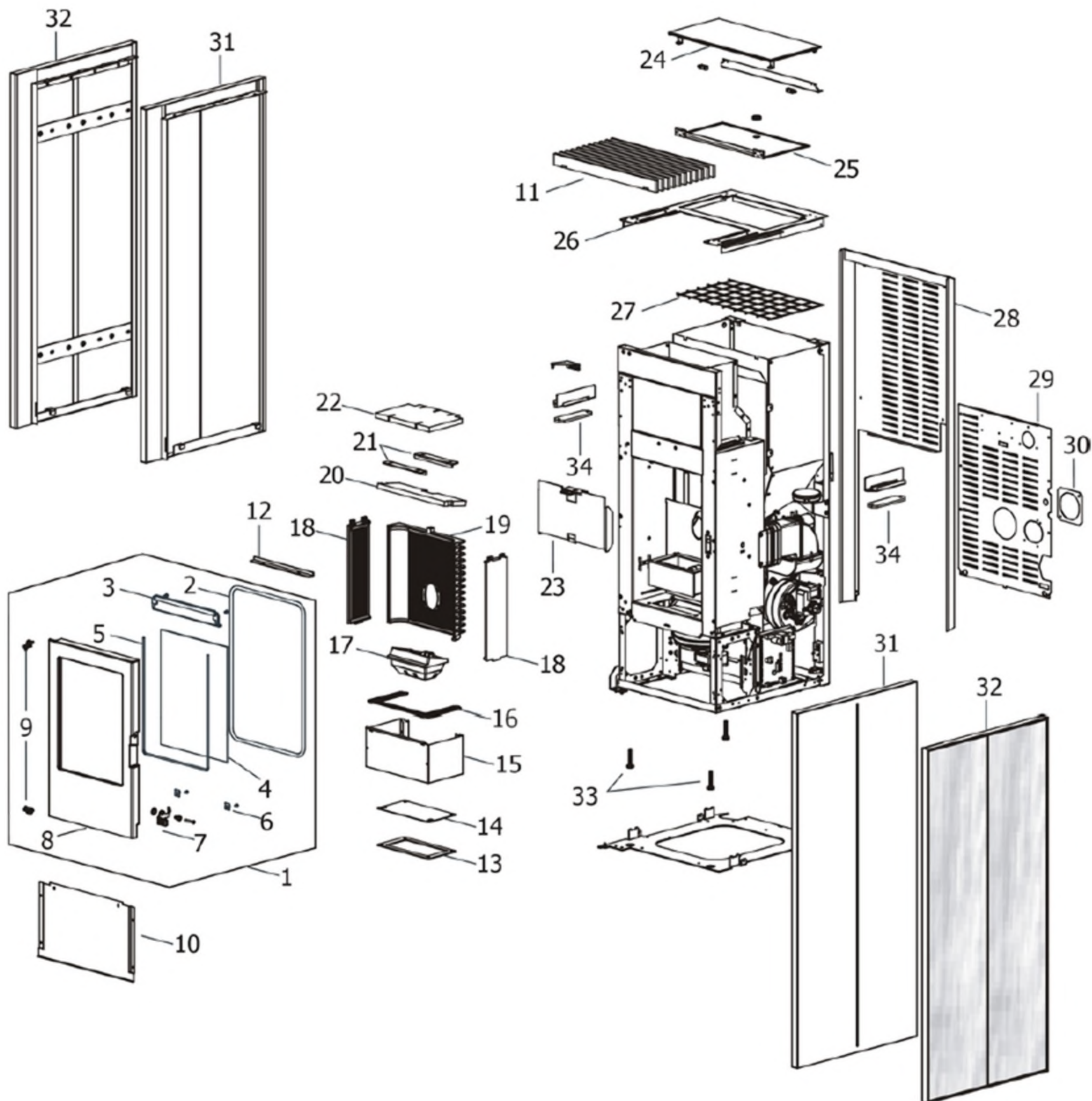

KLIN

Componenti Struttura Esterna / External structure components / Bauteile Aussenkorpus / Composants structure externe / Componentes estructura externa

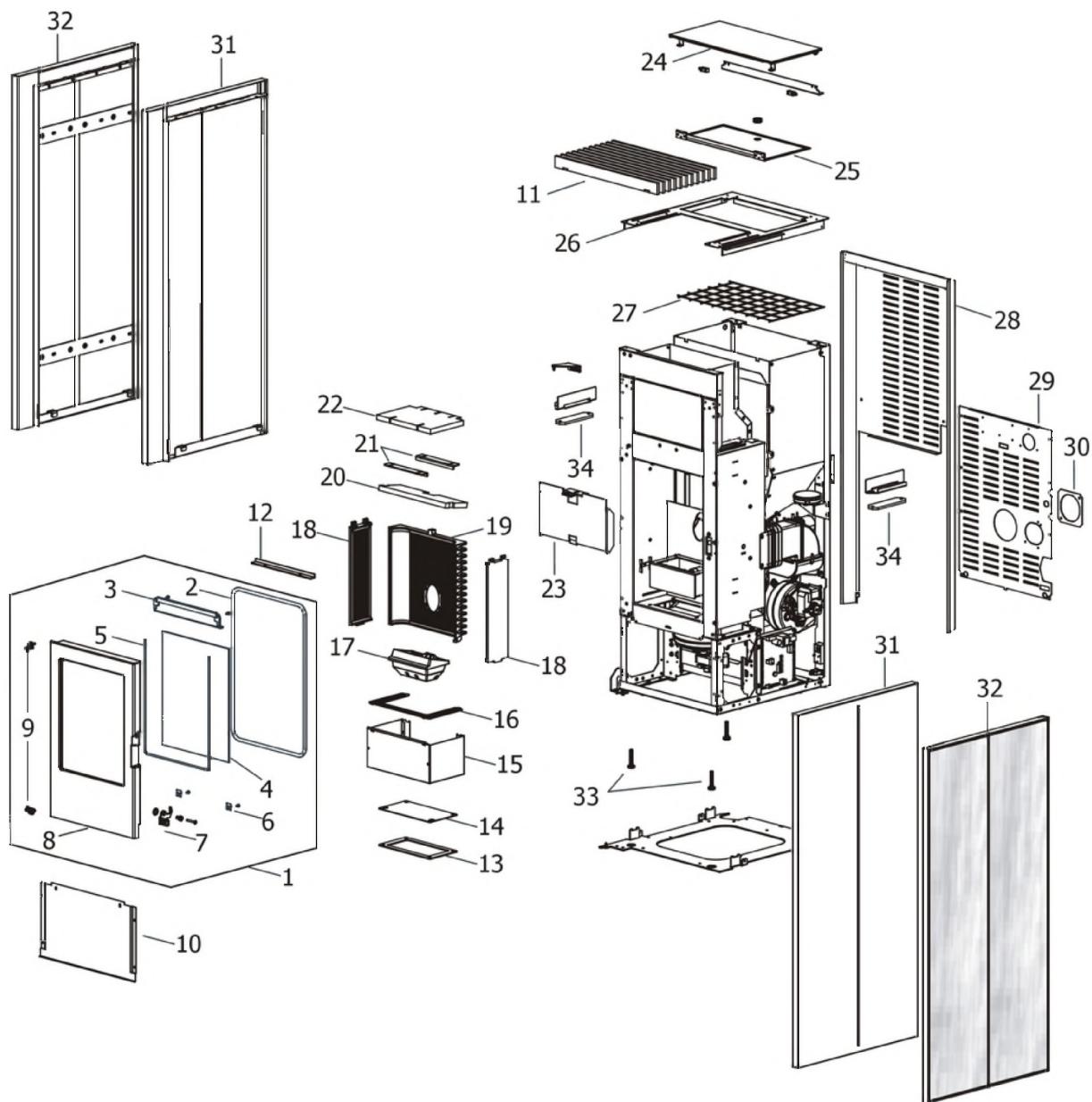

N°	Codice/Code	Descrizioni / Description / Beschreibung / Description / Descripción	Prezzo (€)
1	41301500250	Porta fuoco completa in ghisa / Cast iron complete fire door / Komplette Feuertür aus Guß / Porte foyer complète en fonte / Puerta hogar completa de arrabio	223.00
2	41201031	Kit sostituzione cordino (cordino+silicone) Ø 10 mm / Cord replacement kit (cord + silicon) Ø 10 mm / Schnuraustauschsatz (Schnur+Silikon) Ø 10 mm / Kit remplacement cordon (cordon + silicone) Ø 10 mm / Kit sustitución junta a cuerda (junta a cuerda+silicón) Ø 10 mm	43.00
2	4120103A	Cordino fibroceramico Ø 10 mm (5 mt.) / Ceramic fibre cord Ø 10 mm (5 m) / Keramikfaserschnur Ø 10 mm (5 m) / Cordon en fibre céramique Ø 10 mm (5 m) / Junta a cuerda de fibra cerámica Ø 10 mm (5 m)	29.00
2	4120103B	Cordino fibroceramico Ø 10 mm (50 mt.) / Ceramic fibre cord Ø 10 mm (50 m) / Keramikfaserschnur Ø 10 mm (50 m) / Cordon en fibre céramique Ø 10 mm (50 m) / Junta a cuerda de fibra cerámica Ø 10 mm (50 m)	167.00
3	41400905730V	Deflettore porta / Door deflector / Tür Leitblech / Déflecteur de la porte / Deflector de la puerta	26.00
4	41700900300	Vetroceramico con guarnizione / Glass with gasket / Glaskeramikscheibe mit Dichtung / Vitrocéramique avec joint / Cristal cerámico con guarnición	120.00
5	4120106	Guarnizione a nastro fireglass / Fireglass tape gasket / Banddichtung Fireglass / Joint ruban Fireglass / Guarnición a cinta Fireglass	28.00

6	41401077430	Staffe di fissaggio vetroceramico (4 pz.) / Pyroceram fastening brackets (4 pcs.) / Befestigungsbügel Glaskeramik (4 Stck.) / Étrier de fixation vitrocéramique (4 pz.) / Abrazaderas de fijación vidrio cerámico (4 piezas)	21.00
7	41411501860	Maniglia completa / Complete handle / Kompletter Griff / Poignée complète / Tirador completo	23.00
8	41301500300V	Telaio porta fuoco in ghisa / Cast iron fire door frame / Feuertürrahment aus Guß / Cadre porte foyer en fonte / Armazón puerta hogar de arrabio	111.00
9	412008063	Cerniere porta fuoco (2 pz) / Fire door hinge (2pcs) / Scharnier Feuertür (2 Stck) / Charnière porte foyer (2 pcs) / bisagra puerta del hogar (2 pz)	27.00
10	41411503530V	Componente sottoporta / Part under the door / Stück unter der Tür / Composant sous porte / Componente abajo puerta	29.00
11	41411503640P	Griglia aria / Air grille / Luftgitter / Grille air / Rejilla aire	170.00
12	41401382130	Deflettore / Deflector / Leitblech / Déflecteur / Deflector	24.00
13	41800900600	Guarnizione / Gasket / Dichtung / Joint / Junta	21.00
13	41801599750	Kit 50 guarnizioni / Kit 50 gaskets / Bausatz 50 Dichtungen / Kit 50 joints / Kit 50 juntas	840.00
14	41401339610	Tappo ispezione vano fumi / Smoke compartment inspection plug / Inspektionsdeckel Rauchabzug / Clapet inspection compartiment fumées / Tapón inspección compartimento humos	21.00
15	41401506030V	Cassetto cenere / Ash drawer / Aschenkasten / Tiroir à cendres / Cajón ceniza	63.00
16	41411520410V	Griglia cassetto cenere / Ash drawer grille / Aschenkastengitter / Grille tiroir à cendres / Rejilla cajón ceniza	30.00
17	41301402101V	Braciere / Brazier / Brennschale / Brasero / Brasero	59.00
18	41301302400V	Laterale in ghisa / Cast iron side / Seite aus Guß / Côté en fonte / Placa lateral de arrabio	33.00
18	41301302400V	Laterale in ghisa / Cast iron side / Seite aus Guß / Côté en fonte / Placa lateral de arrabio	33.00
19	41301302300V	Schiena in ghisa / Cast iron back / Rückwand aus Guß / Fond en fonte / Parte trasera de arrabio	54.00
20	41151401000	Deflettore in vermiculite / Vermiculite deflector / Leitblech aus Vermiculite / Déflecteur en vermiculite / Deflector en vermiculite	29.00
20	41331504730	Rinforzo per vermiculite / Vermiculite support / Vermiculite Stutze / Renfort pour vermiculite / Refuerzo para vermiculite	28.00
21	41401421630	Staffa supporto protezione in vermiculite (2 pz) / Vermiculite protection bracket (2 pcs) / Haltebügel für Schutzpaneel aus Vermiculite (2 Stck) / Patte support protection en vermiculite (2 pcs) / Estribo soporte protección en vermiculite (2 pzs)	25.00
22	41151400900	Protezione in vermiculite / Vermiculite protection / Schutzpaneel aus Vermiculite / Protection en vermiculite / Protección en vermiculite	31.00
23	41401421030	Schiena asportabile / Amovable wall / Abnehmbares Wand / Fond démontable / Pared extirpable	36.00
24	41411503230P	Coperchio serbatoio pellet con vetro / Pellet hopper cover with glass / Deckel Pelletbehälter mit Glass / Couvercle réservoir pellet avec vitre / Tapadera depósito con cristal	143.00
25	41411501740V	Griglia protezione / Protection grille / Sicherheitsgitter / Grille protection / Rejilla de protección	54.00
26	41411501431V	Supporto top / Top support / Deckelhaltebügel / Support du dessus / Soporte top	71.00
27	41401423960	Griglia antintrusione / Hopper protection grille / Schutzgitter Pelletbehälter / Grille de protection réservoir / Rejilla de protección depósito	31.00
28	41411503430P	Schiena esterna nera / Black back / Schwarze Rückwand / Dossieret extérieur noir / Parte trasera negra	105.00
29	41401424961	Schiena posteriore inferiore / Lower rear back / Untere hintere Rückwand / Dossieret postérieur inférieur / Parte trasera inferior	39.00
30	41400904810	Flangia tubo ingresso aria / Flange for combustion air aspiration tube / Flansch Verbrennungsluft Förderrohr / Bride tuyau aspiration air comburant / Brida tubo aspiración aire de combustión	20.00
31	6915010	Rivestimento completo Metal Black / Metal Black complete cladding / Metal Black komplette Verkleidung / Habillage complet Metal Black / Revestimiento completo Metal Black	245.00
31	6915010	Rivestimento completo Metal Black / Metal Black complete cladding / Metal Black komplette Verkleidung / Habillage complet Metal Black / Revestimiento completo Metal Black	245.00
32	41251500151	Fianco DX in Serpentino / R. side made of Serpentino / R. Seite aus Serpentino / Côté D. en Serpentino / Lado DCHO en Serpentino	624.00
32	41251500251	Fianco SX in Serpentino / L. side made of Serpentino / L. Seite aus Serpentino / Côté G. en Serpentino / Lado IZDO en Serpentino	624.00
32	41251500151	Fianco DX in Serpentino / R. side made of Serpentino / R. Seite aus Serpentino / Côté D. en Serpentino / Lado DCHO en Serpentino	624.00
32	41251500251	Fianco SX in Serpentino / L. side made of Serpentino / L. Seite aus Serpentino / Côté G. en Serpentino / Lado IZDO en Serpentino	624.00
33	41200906660	Piedini di appoggio (4 pz.) / Support feet (4 pcs.) / Einstellfüße (4 Stck.) / Vérins d'appui (4 p.es) / Pies de apoyo (4 piezas)	19.00
34	41801400900	Guarnizione / Gasket / Dichtung / Joint / Junta	21.00
34	41801599650	Kit 50 guarnizioni / Kit 50 gaskets / Bausatz 50 Dichtungen / Kit 50 joints / Kit 50 juntas	840.00

34	41801400900	Guarnizione / Gasket / Dichtung / Joint / Junta	21.00
34	41801599650	Kit 50 guarnizioni / Kit 50 gaskets / Bausatz 50 Dichtungen / Kit 50 joints / Kit 50 juntas	840.00

MCZ GROUP

KLIN

Porta fuoco / Fire door / Feuertür / Porte foyer / Puerta hogar

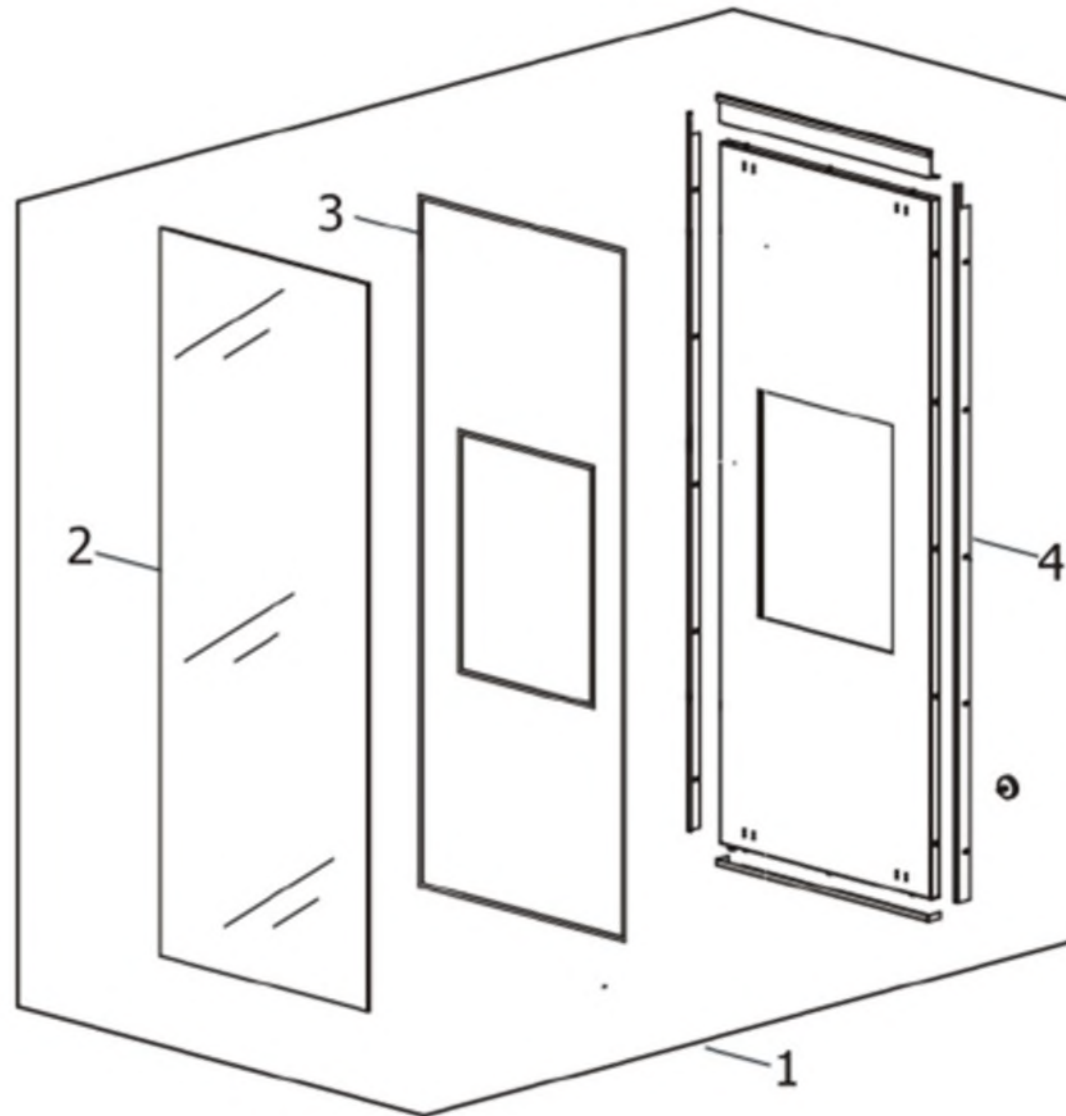

KLIN

Porta fuoco / Fire door / Feuertür / Porte foyer / Puerta hogar

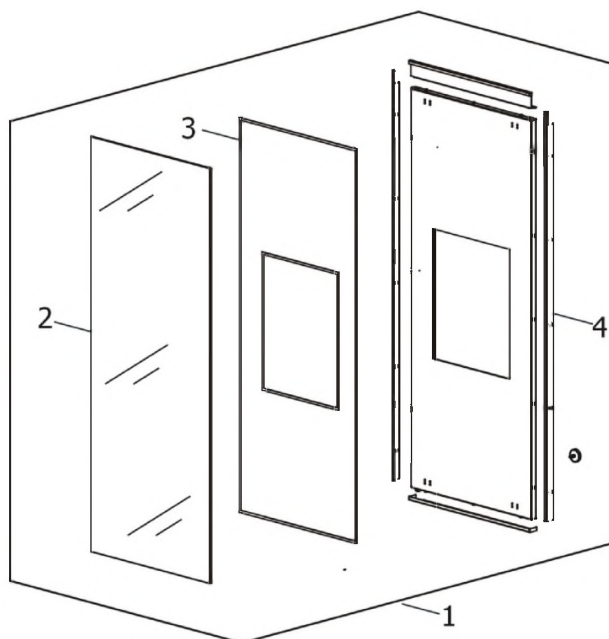

N°	Codice/Code	Descrizioni / Description / Beschreibung / Description / Descripción	Prezzo (€)
1	41411501950	Porta esterna completa / Complete external door / Komplette Außentür / Porte extérieure complète / Puerta exterior completa	550.00
2	41701500160	Vetro porta esterna / External door glass / Außentürscheibe / Vitre porte extérieure / Cristal puerta exterior	467.00
3	4120572A	Guarnizione a nastro 6 mm (5 mt.) per porta / Door strip gasket 6 mm (5 m) / Türbanddichtung 6 mm (5 m) / Joint ruban 6 mm (5 m) pour porte / Guarnición de cinta para puerta 6 mm (5 m)	33.00
3	4120572B	Guarnizione a nastro 6 mm (50 mt.) per porta / Door strip gasket 6 mm (50 m) / Türbanddichtung 6 mm (50 m) / Joint ruban 6 mm (50 m) pour porte / Guarnición de cinta para puerta 6 mm (50 m)	210.00
4	41411501940V	Telaio porta esterna / External door frame / Außentürrahmen / Cadre porte extérieure / Armazón puerta exterior	190.00
4	41411502430P	Fermavetro inferiore - porta esterna / Lower glass fastening bracket - External door / Unteres Haltebügel für Scheibebefestigung - Außentür / Etrier de fixation inférieur vitrocéramique - porte extérieur / Retendor inferior del cristal - Puerta exterior	37.00
4	41411502530P	Fermavetro DX - porta esterna / R. glass fastening bracket - External door / R. Haltebügel für Scheibebefestigung - Außentür / Etrier D. de fixation vitrocéramique - porte extérieure / Retendor DCHO del cristal - Puerta exterior	46.00
4	41411502630P	Fermavetro SX - porta esterna / L. glass fastening bracket - External door / L. Haltebügel für Scheibebefestigung - Außentür / Etrier G. de fixation vitrocéramique - porte extérieure / Retendor IZDO del cristal - Puerta exterior	45.00
4	41411502730P	Fermavetro superiore - porta esterna / Upper glass fastening bracket - External door / Oberes Haltebügel für Scheibebefestigung - Außentür / Etrier de fixation supérieur vitrocéramique - porte extérieur / Retendor superior del cristal - Puerta exterior	25.00

MCZ GROUP

KLIN

Componenti interni meccanici ed elettronici / **Electronic and mechanic internal parts** / Interne mechanische und elektronische Bauteile / Composants internes mécaniques et électroniques / Componentes internos electrónicos y mecánicos

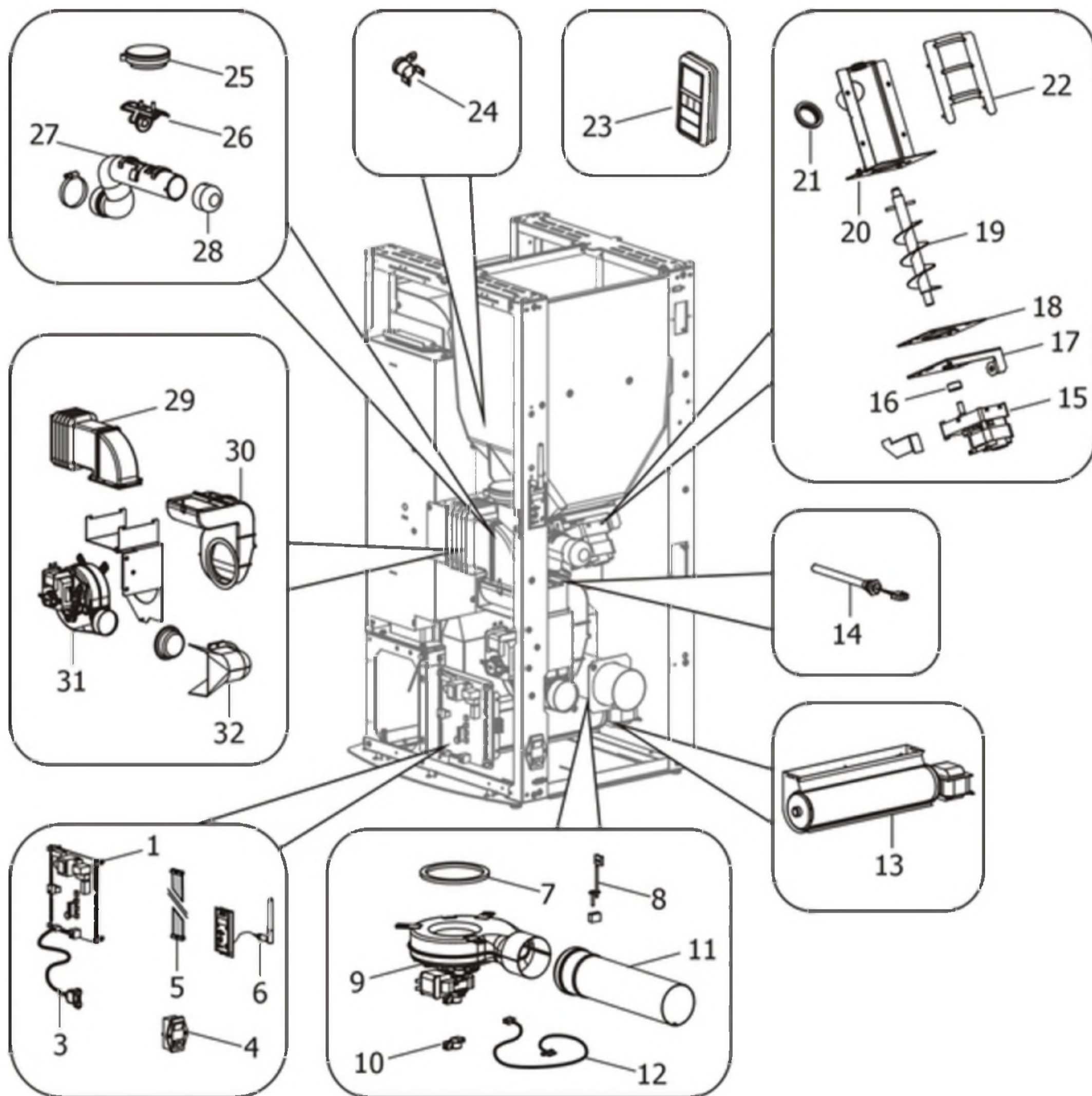

KLIN

Componenti interni meccanici ed elettronici / Electronic and mechanic internal parts / Interne mechanische und elektronische Bauteile / Composants internes mécaniques et électroniques / Componentes internos electrónicos y mecánicos

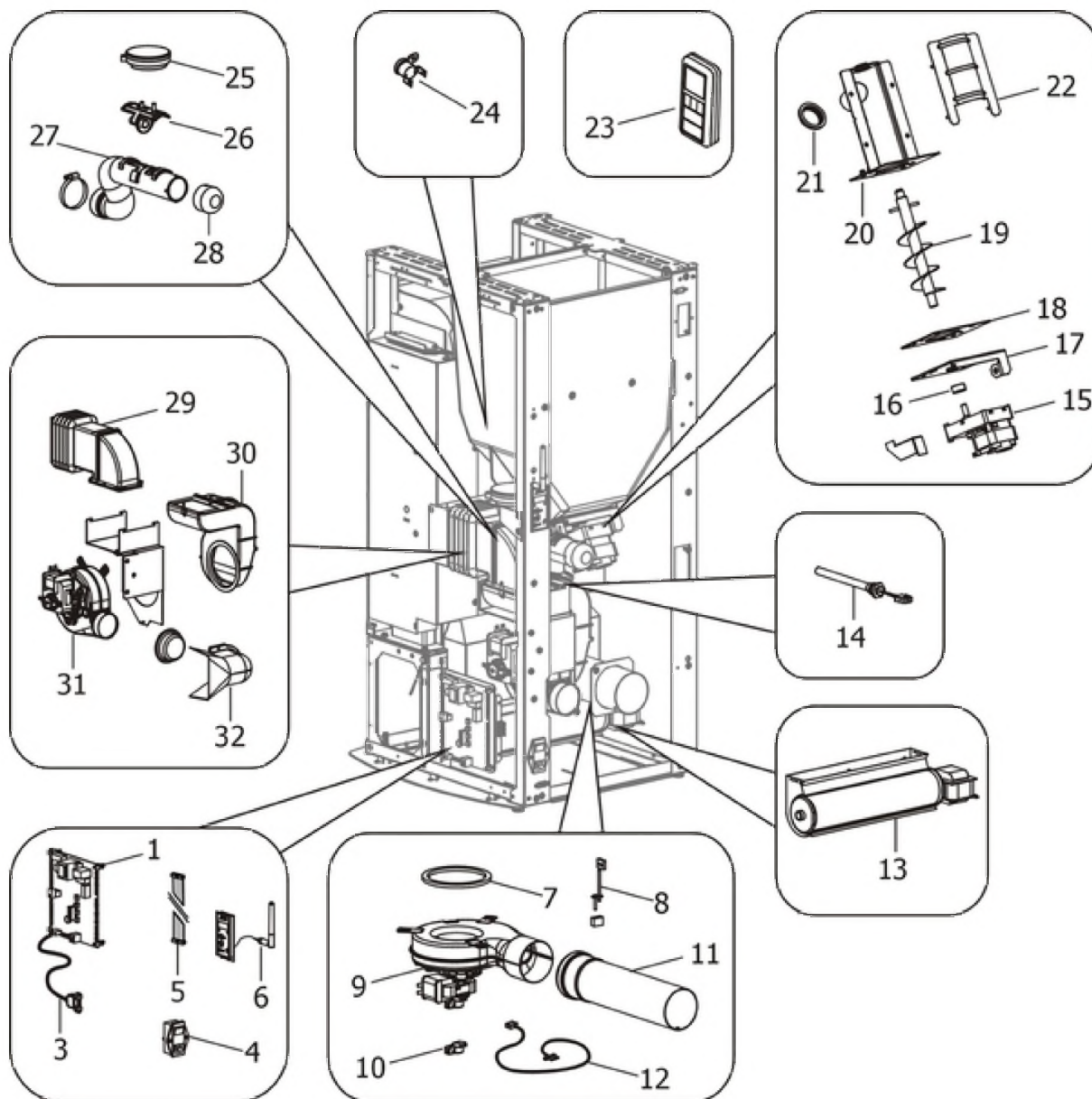

N°	Codice/Code	Descrizioni / Description / Beschreibung / Description / Descripción	Prezzo (€)
1	41451303805	Scheda madre Hottoh 148 / Hottoh motherboard 148 / Hauptplatine Hottoh 148 / Carte mère Hottoh 148 / Tarjeta madre Hottoh 148	170.00
1	41451303807	Scheda madre Hottoh 148 / Hottoh motherboard 148 / Hauptplatine Hottoh 148 / Carte mère Hottoh 148 / Tarjeta madre Hottoh 148	210.00
1	41801499750	Kit 868 / Kit 868 / Kit 868 / Kit 868 / Kit 868	192.00
3	41451403200	Cavo USB da pannello L.500 / USB Cable from display L.500 / USB Kabel von Notfalldisplay L.500 / Câble USB de panneau L.500 / Cable USB del panel L.500	21.00
4	4160193	Pulsante accensione / On/Off button / Zündungstaste / Touche d'allumage / Botón encendido	28.00
5	41450902500	Cavo flat / Flat cable / Flat-Kabel / Cable flat / Cable flat	20.00
6	41451404100	Pannello emergenza completo di antenna / Emergency display / Notfalldisplay mit Antenne / Panneau d'urgence avec antenne / Panel emergencia con antena	89.00
6	41451404700	Antenna 434 Mhz / Antenna 434 Mhz / Antenne 434 Mhz / Antenne 434 Mhz / Antena 434 Mhz	19.00

6	41801499750	Kit 868 / Kit 868 / Kit 868 / Kit 868 / Kit 868	192.00
7	41801002600	Guarnizione adesiva voluta fumi / Adhesive gasket smoke volute / Haftendichtung Rauchvolute / Joint adhesive volute fumées / Junta adhesiva voluta humos	20.00
7	41801599850	Kit 50 guarnizioni / Kit 50 gaskets / Bausatz 50 Dichtungen / Kit 50 joints / Kit 50 juntas	800.00
8	41451404500	Sonda fumi con flangia / Smoke sensor with flange / Rauchsonde mit Flansche / Sonde fumées avec bride / Sonda humos con brida	25.00
9	41451406501	Ventilatore fumi / Smoke exhausted fan / Rauchgasgebläse / Ventilateur fumées / Ventilador humos	109.00
9	41801102500	Guarnizione / Gasket / Dichtung / Joint / Junta	21.00
9	41452009200	Encoder ventilatore / Fan encoder / Lüfter Encoder / Encodeur de ventilateur / Codificador de ventilador	17.00
10	41451209300	Encoder per ventilatore fumi marchi LN2/SIT / Encoder for LN2/SIT smoke fan / Encoder für LN2/SIT Rauchgasgebläse / Encoder pour ventilateur des fumées marques LN2/SIT / Encoder para ventilador humos marcas LN2/SIT	21.00
11	41601402860	Tubo fumi Ø 80 con guarnizione / Smoke pipe Ø 80 with gasket / Rauchrohr Ø 80 mit Dichtung / Tuyau fumées Ø 80 avec joint / Tubo humos Ø 80 con junta	37.00
12	41451402301	Cablaggio completo / Complete wiring / Komplette Verkabelung / Câblage complet / Cableado completo	89.00
12	41451700800	Cavo encoder / Encoder cable / Drehzahlmesser-kabel / Câble encoder / Cable codificador	29.00
13	414508035	Ventilatore aria calda / Warm air fan / Warmluftgebläse / Ventilateur air chaud / Ventilador aire caliente	101.00
14	41451401800	Candeletta 350 Watt / Sparkplug 350 Watt / Zündkerze 350 Watt / Bougie 350 Watt / Bujía 350 Watt	48.00
14	41801599250	Kit 50 candelette 350 Watt / 50 Sparkplugs 350 Watt kit / Bausatz 50 Zündkerzen 350 Watt / Kit 50 Bougies 350 Watt / Kit 50 Bujías 350 Watt	1,920.00
15	41451301300	Motoriduttore 1,5 RPM C/ENCODER / Reduction motor 1,5 RPM + ENCODER / Getriebemotor 1,5 RPM + ENCODER / Motoréducteur 1,5 RPM + ENCODER / Motorreductor 1,5 RPM + ENCODER	116.00
16	4120398	Connettore motoriduttore-coclea / Reduction motor-feed screw connector / Verbindung Getriebemotor-Schnecke / Connecteur motoréducteur-vis sans fin / Conector motorreductor-cóclea	22.00
17	41401421340	Base coclea con boccia / Feed screw base with bush / Untergestell der Förderschnecke mit Buchse / Base de la vis sans fin avec douille / Base de la cóclea con abrazadera	64.00
18	4120615	Guarnizione base della coclea / Feed screw base gasket / Dichtung Untergestell der Förderschnecke / Joint pour la base de la vis sans fin / Junta base de la cóclea	19.00
19	41201301040	Coclea di caricamento pellet / Pellet feed screw / Pellet Förderschnecke / Vis sans fin pour chargement du pellet / Cóclea de carga pellet	48.00
20	41401421140V	Condotto della coclea / Feed screw conduit / Rohrleitung der Förderschnecke / Conduit de la vis sans fin / Conducto de la cóclea	86.00
21	41801210100	Guarnizione / Gasket / Dichtung / Joint / Junta	20.00
22	41401202140	Coperchio coclea / Feed screw cover / Deckel der Rohrleitung / Couvercle de la vis sans fin / Tapa de la cóclea	35.00
23	41451301203	Telecomando nero 434,5MHZ - Funzione impostabile da 0 a 3 Ventilatori / Black remote control 434,5MHZ - From 0 to 3 fan function / Schwarze Fernbedienung 434,5MHZ - Von 0 bis 3-Gebläse-Steuerung / Télécommande noire 434,5MHZ - Fonctionne à partir de 0 à 3 Ventilateurs / Mando a distancia negro 434,5MHZ - Función de 0 a 3 ventiladores	123.00
23	41801499750	Kit 868 / Kit 868 / Kit 868 / Kit 868 / Kit 868	192.00
24	412007004	Clickson 110°C / Clickson 110°C / Clickson 110°C / Clickson 110°C / Clickson 110°C	20.00
25	41451303400	Trasduttore di pressione / Pressure transducer / Active-Wandler / Transducteur de pression / Transductor de pression	58.00
26	41601301850	Componente rilevamento portata aria / Air flow measure component / Bauteil für Messung der Luftmenge / Composent pour la mesuration de la quantité d'air / Componente por la medida de l'aire	34.00
27	41801400800	Tubo ingresso aria in gomma / Rubber air inlet pipe / Lufteingangsrohr aus Gummi / Tuyau entrée d'air en caoutchouc / Tubo entrada aire de goma	31.00
28	41401036100	Filtro antipolvere / Anti-dust filter / Staubschutzfilter / Filtre antipoussière / Filtro de protección polvo	21.00
29	41801303600	Tubo in silicone / Silicone pipe / Silikonrohr / Tuyau en silicone / Tubo de silicona	35.00
30	41801303400	Convogliatore in silicone / Silicone air conveyer / Silikonblech / Convoyeur en silicone / Conductor de silicona	43.00
31	41451402400	Ventilatore aria / Air fan / Luftgebläse / Ventilateur air / Ventilador aire	76.00
32	41801403900	Diffusore aria calda / Hot air diffusor / Wärmeluftverteilungsstück / Diffuseur air chaude / Difusor aire caliente	22.00