

MUSA HYDROMATIC 16 KW

Componenti Struttura Esterna / External structure components / Bauteile Aussenkorpus / Composants structure externe / Componentes estructura externa

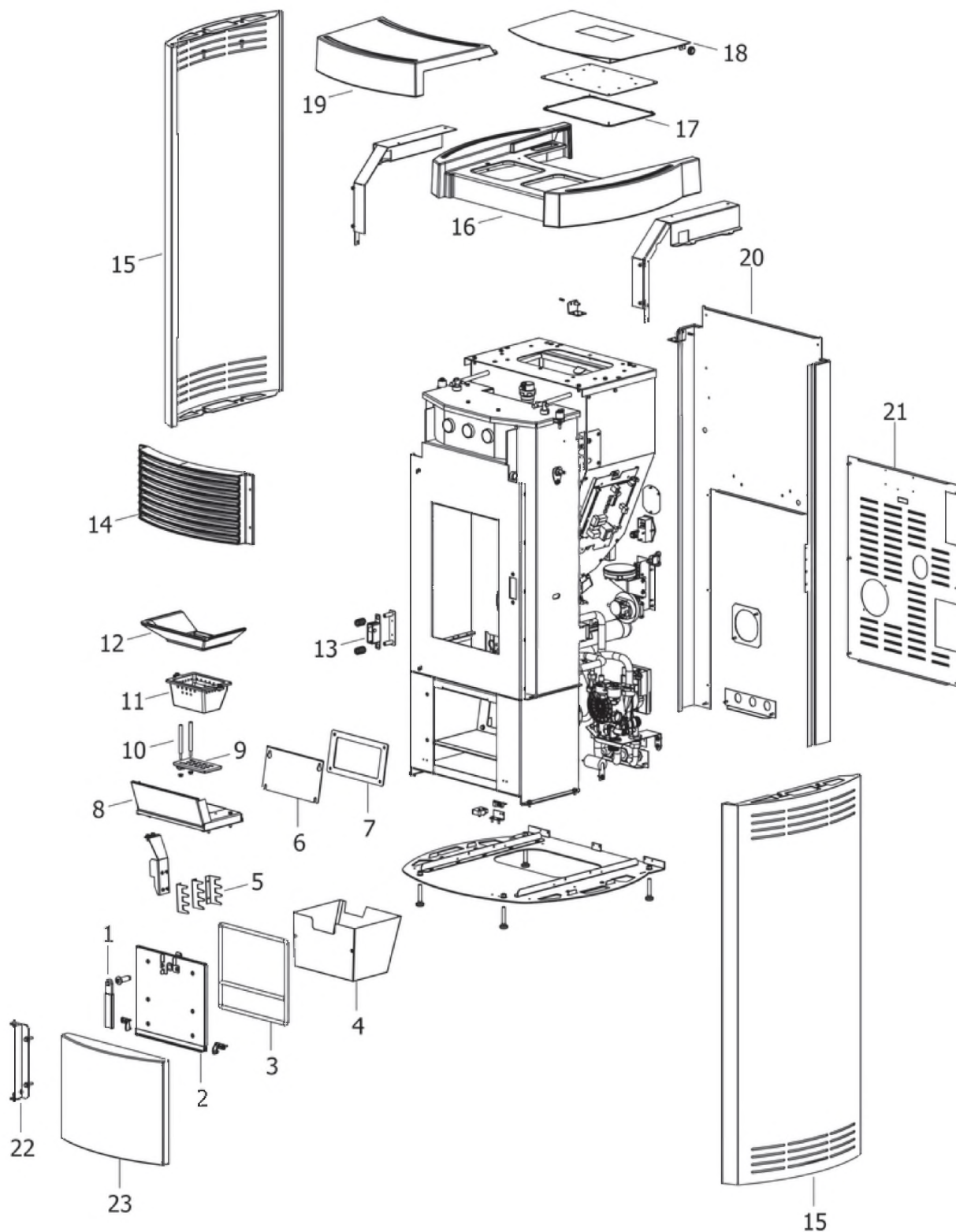

N°	Codice/Code	Descrizioni / Description / Beschreibung / Description / Descripcion	Prezzo (€)
1	41411621600	Maniglia con impugnatura porta cenere / Handle / Griff / Poignée / Tirador	20.00
2	437016077	Porta cassetto cenere / Ash drawer door / Tür des Aschenkastens / Porte tiroir à cendres / Puerta cajón ceniza	124.00

MCZ GROUP

MUSA HYDROMATIC 16 KW

Componenti Struttura Esterna / External structure components / Bauteile Aussenkorpus / Composants structure externe / Componentes estructura externa

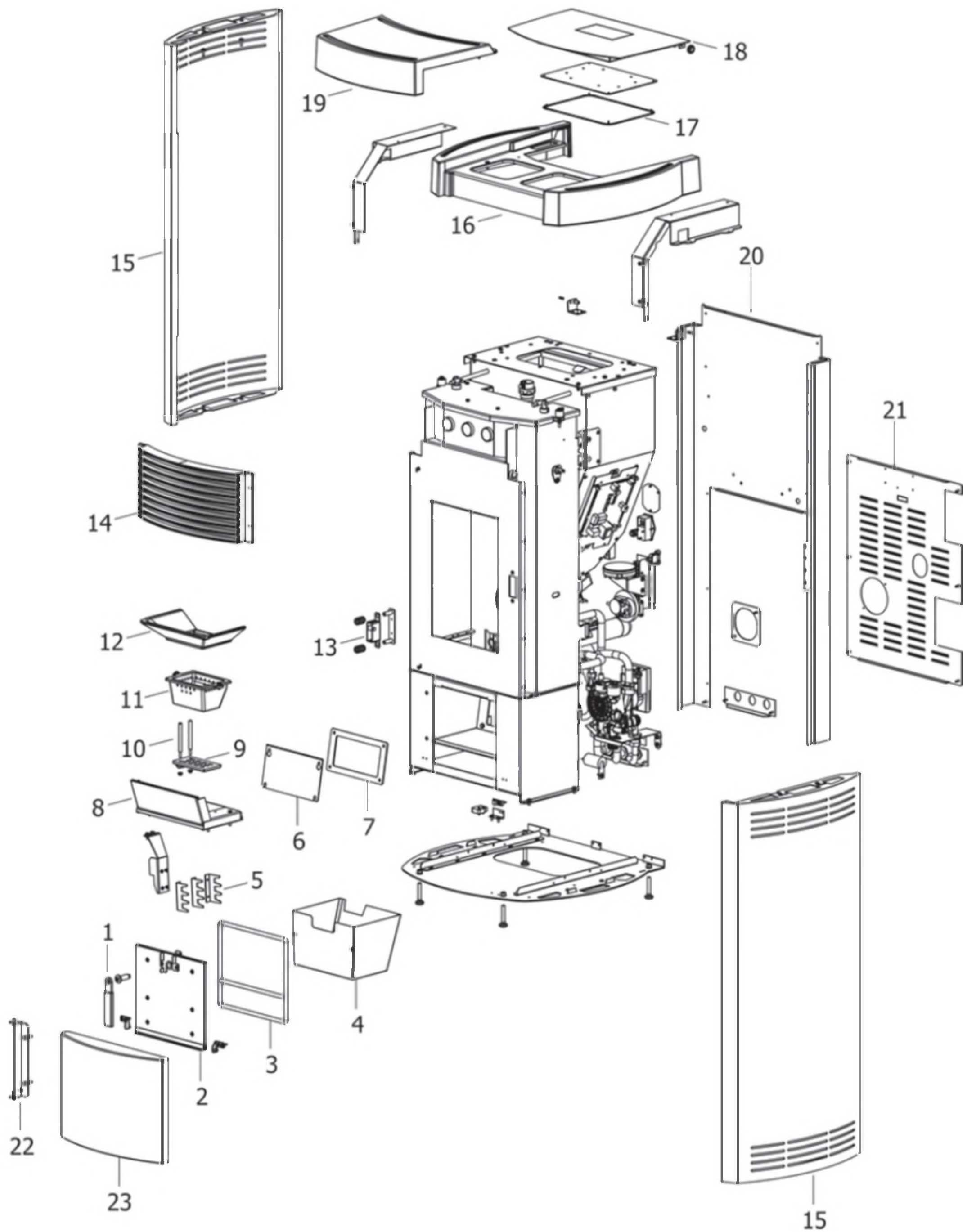

3	4120104A	Cordino fibroceramico Ø 12 mm (5 mt.) / Ceramic fibre cord Ø 12 mm (5 m.) / Keramikfaserschur Ø 12 mm (5 m) / Cordon en fibre céramique Ø 12 mm (5 m) / Junta a cuerda de fibra cerámica Ø 12 mm (5 m)	36.00
3	4120104B	Cordino fibroceramico Ø 12 mm (50 mt.) / Ceramic fibre cord Ø 12 mm (50 m.) / Keramikfaserschur Ø 12 mm (50 m) / Cordon en fibre céramique Ø 12 mm (50 m) / Junta a cuerda de fibra cerámica Ø 10 mm (52 m)	210.00
3	41201041	Kit sostituzione cordino (cordino+silicone) Ø 12 mm / Cord replacement kit (cord + silicon) Ø 12 mm / Schnuraustauschsatz (Schnur+Silikon) Ø 12 mm / Kit remplacement cordon (cordon + silicone) Ø 12 mm / Kit sustitución junta a cuerda (junta a cuerda+silicon) Ø 12 mm	50.00
4	437016041	Cassetto cenere / Ash drawer / Aschenkasten / Tiroir à cendres / Cajón ceniza	56.00
5	41401605730	Spuntoni fondo braciere / Bottom fireplace scraper / Brennertopf Kratzer / Racleur fond foyer / Raspador fondo hogar	21.00
6	41401605530	Tappo camera fumi zincato / Smoke compartment galvanized plug / Verzinktes Rauchabzugklappe / Join zingué compartiment fumées / Tapón galvanizado compartimento humos	20.00
7	41801601300	Guarnizione tappo camera fumi / Smoke compartment plug gasket / Dichtung Rauchabzugklappe / Joint clapet compartiment fumées / Junta tapón compatimento humos	19.00
8	41411609440V	Convogliatore aria vetro / Air duct / Luftförderer / Convoyeur d'air / Canalizador aire	78.00
9	41301601000V	Fondo braciere ghisa autopulente / Self-cleaning cast iron grate bottom / Selbstreinigend Brennertopf aus Gusseisen Boden / Fond brasero en fonte autonettoyant / Fondo brasero en arrabio autolimpiador	44.00
10	41201601400	Perno fondo braciere autopulente (pz.2) / Self-cleaning cast iron bottom grate pin (Pcs.2) / Selbstreinigend Brennertopf aus Gusseisen Bolzen Boden (Stk.2) / Pivot fond brasero en fonte autonettoyant (Pcs.2) / Perno fondo brasero en arrabio autolimpiador (Pz.2)	33.00
11	41301601100V	Braciere ghisa autopulente / Self-cleaning cast iron grate / Selbstreinigend Brennertopf aus Gusseisen / Brasero en fonte autonettoyant / Brasero en arrabio autolimpiador	55.00
12	41301601200V	Scivolo braciere ghisa autopulente / Self-cleaning grate amp / Selbstreinigend Brennertopf Rutsche / Glissière brasero autonettoyant / Tobogán brasero autolimpiador	64.00
13	41411599950	Kit serratura ammortizzato / Pressur relief kit / Bausatz Überdruckablaud Brennkammer / Kit deocompression chambre comcusion / Kit decompression camara combustion	46.00
14	41301503100V	Griglia aria superiore in ghisa / Upper cast iron air grille / Obere Luftgitter aus Guß / Grille air supérieur en fonte / Rejilla aire superior de arrabio	77.00
15	6916011	Rivestimento copleto Metal White / Metal White complete cladding / Metal White komplette Verkleidung / Habillage complet Metal White / Revestimiento completo Metal White	355.00
15	6916011	Rivestimento copleto Metal White / Metal White complete cladding / Metal White komplette Verkleidung / Habillage complet Metal White / Revestimiento completo Metal White	355.00
15	6916012	Rivestimento copleto Metal Silver / Metal Silver complete cladding / Metal Silver komplette Verkleidung / Habillage complet Metal Silver / Revestimiento completo Metal Silver	355.00
15	6916012	Rivestimento copleto Metal Silver / Metal Silver complete cladding / Metal Silver komplette Verkleidung / Habillage complet Metal Silver / Revestimiento completo Metal Silver	355.00
15	6916013	Rivestimento completo Metal Black / Metal Black complete cladding / Metal Black komplette Verkleidung / Habillage complet Metal Black / Revestimiento completo Metal Black	355.00
15	6916013	Rivestimento completo Metal Black / Metal Black complete cladding / Metal Black komplette Verkleidung / Habillage complet Metal Black / Revestimiento completo Metal Black	355.00
15	6916014	Rivestimento copleto Metal Bordeaux / Metal Bordeaux complete cladding / Metal Bordeaux komplette Verkleidung / Habillage complet Metal Bordeaux / Revestimiento completo Metal Bordeaux	355.00
15	6916014	Rivestimento copleto Metal Bordeaux / Metal Bordeaux complete cladding / Metal Bordeaux komplette Verkleidung / Habillage complet Metal Bordeaux / Revestimiento completo Metal Bordeaux	355.00
16	41301400560	Top in ghisa / Cast iron top / Topplatte aus Guß / Dessus en fonte / Top de arrabio	111.00
17	41801504700	Guarnizione tenuta serbatoio / Pellet hopper gasket / Pelletbehälter Dichtung / Joint réservoir pellet / Junta depósito pellet	21.00
18	41411610641P	Coperchio serbatoio completo nero / Complete black hopper cover / Schwarz komplet Deckel Pelletbehälter / Couvercle réservoir complet noir / Tapa depósito completa negra	98.00
19	41301502900V	Frontalino superiore in ghisa / Cast iron upper panel / Obere Platte aus Guss / Plaque supérieure en fonte / Panel superior de arrabio	86.00
20	41411609930P	Schienale nero / Black back panel / Schwarz hintere Paneel / Panneau posterieur noir / Panel posterior negro	83.00
20	4141160994100	Schienale nero / Black back panel / Schwarz hintere Paneel / Panneau posterieur noir / Panel posterior negro	99.00
21	41411610131P	Pannello posteriore nero / Black rear panel / Hintere schwarze Rückwand / Panneau postérieur noir / Panel trasero negro	55.00
21	41411610132P	Pannello posteriore nero / Black rear panel / Hintere schwarze Rückwand / Panneau postérieur noir / Panel trasero negro	55.00
21	4141161013300	Pannello posteriore nero / Black rear panel / Hintere schwarze Rückwand / Panneau postérieur noir / Panel trasero negro	83.00
22	41411611030V	Supporto pannello inferiore nero / Black lower panel support / Untere Paneel Gestell / Support panneau inferieur noir / Soporte panel inferior negro	46.00
23	41201305100	Chiusura a spinta / Push-pull pressure closing / Druckschließung / Fermeture par pression / Cierre a presión	20.00

23	41301503000V	Pannello inferiore in ghisa / Lower cast iron tile / Unteres Paneel aus Gusseisen / Panneau inférieur en fonte / Panel inferior en arrabio	62.00
----	--------------	--	-------

MCZ GROUP

MUSA HYDROMATIC 16 KW

Porta fuoco / Fire door / Feuertür / Porte foyer / Puerta hogar

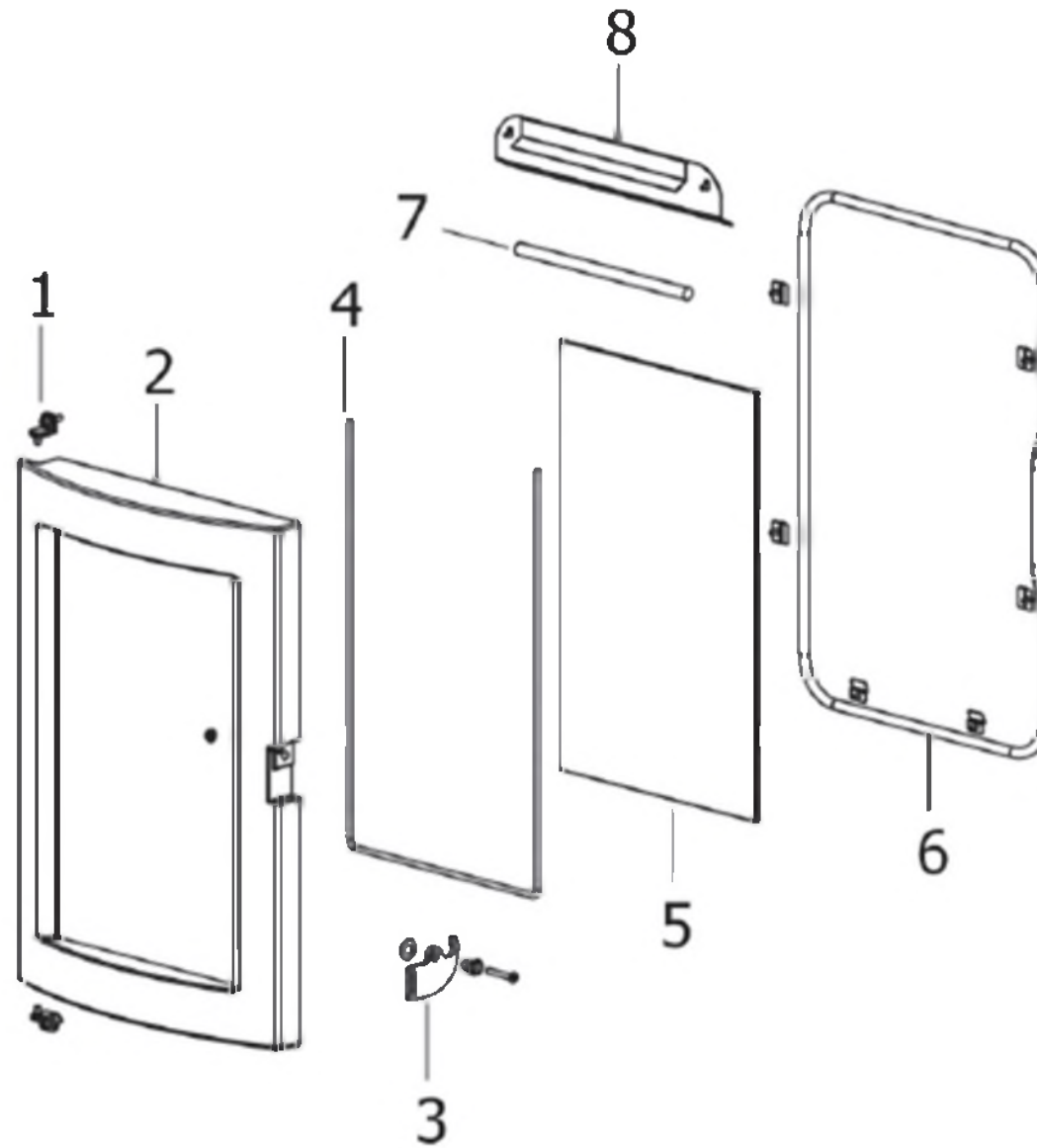

MUSA HYDROMATIC 16 KW

Porta fuoco / Fire door / Feuertür / Porte foyer / Puerta hogar

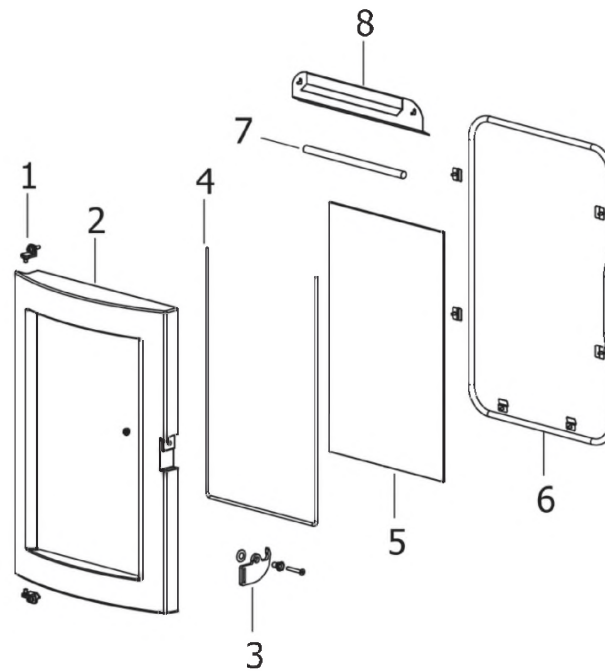

N°	Codice/Code	Descrizioni / Description / Beschreibung / Description / Descripción	Prezzo (€)
1	412008063	Cerniere porta fuoco (2 pz) / Fire door hinge (2pcs) / Scharnier Feuertür (2 Stck) / Charnière porte foyer (2 pcs) / bisagra puerta del hogar (2 pz)	27.00
2	41301400100V	Telaio porta fuoco in ghisa / Cast iron fire door frame / Feuertürrahment aus Guß / Cadre porte foyer en fonte / Armazón puerta hogar de arrabio	145.00
2	41301400101V	Telaio porta fuoco in ghisa / Cast iron fire door frame / Feuertürrahment aus Guß / Cadre porte foyer en fonte / Armazón puerta hogar de arrabio	174.00
2	437016034	Porta focolare / Fireplace door / Feuerstelle Tür / Porte foyer / Puerta hogar	298.00
3	41401424160	Maniglia completa / Complete handle / Kompletter Griff / Poignée complète / Tirador completo	25.00
4	41801603300A	Guarnizione Ø5 5mt / Gasket Ø5 5mt / Dichtung Ø5 5mt / Joint Ø5 5mt / Junta Ø5 5mt	42.00
4	41801603300B	Guarnizione Ø5 50mt / Gasket Ø5 50mt / Dichtung Ø5 50mt / Joint Ø5 50mt / Junta Ø5 50mt	299.00
4	41801603300C	Guarnizione Ø5 5mt + silicone / Gasket Ø5 5mt + silic / Dichtung Ø5 5mt + Silikon / Joint Ø5 5mt + silic / Junta Ø5 5mt	63.00
5	41701400260	Vetroceramico 430x268x4 mm con guarnizione / Glass 430x268x4 mm with gasket / Glasskeramikscheibe 430x268x4 mm mit Dichtung / Vitrocéramique 430x268x4 mm avec joint / Cristal cerámico 430x268x4 mm con junta	127.00
5	41701400261	Vetroceramico 435x268x4 mm con guarnizione / Glass 435x268x4 mm with gasket / Glasskeramikscheibe 435x268x4 mm mit Dichtung / Vitrocéramique 435x268x4 mm avec joint / Cristal cerámico 435x268x4 mm con junta	163.00
6	4120103A	Cordino fibroceramico Ø 10 mm (5 mt.) / Ceramic fibre cord Ø 10 mm (5 m) / Keramikfaserschnur Ø 10 mm (5 m) / Cordon en fibre céramique Ø 10 mm (5 m) / Junta a cuerda de fibra cerámica Ø 10 mm (5 m)	29.00
6	4120103B	Cordino fibroceramico Ø 10 mm (50 mt.) / Ceramic fibre cord Ø 10 mm (50 m) / Keramikfaserschnur Ø 10 mm (50 m) / Cordon en fibre céramique Ø 10 mm (50 m) / Junta a cuerda de fibra cerámica Ø 10 mm (50 m)	167.00
6	41201031	Kit sostituzione cordino (cordino+silicone) Ø 10 mm / Cord replacement kit (cord + silicon) Ø 10 mm / Schnuraustauschsatz (Schnur+Silikon) Ø 10 mm / Kit remplacement cordon (cordon + silicone) Ø 10 mm / Kit sustitución junta a cuerda (junta a cuerda+silicon) Ø 10 mm	43.00
7	41401611030	Deflettore aria vetro / Door deflector / Leitblech der Tür / Déflecteur de la porte / Deflector de la puerta	24.00
8	41411609730V	Profilo tamponazione porta nero / Door filler frame / Türstopfung Profil / Profil tampon porte / Perfil taponado puerta	23.00
8	41411609731V	Profilo tamponazione porta nero / Door filler frame / Türstopfung Profil / Profil tampon porte / Perfil taponado puerta	42.00

MCZ GROUP

MUSA HYDROMATIC 16 KW

Componenti interni meccanici ed elettronici / **Electronic and mechanic internal parts** / Interne mechanische und elektronische Bauteile / Composants internes mécaniques et électroniques / Componentes internos electrónicos y mecánicos

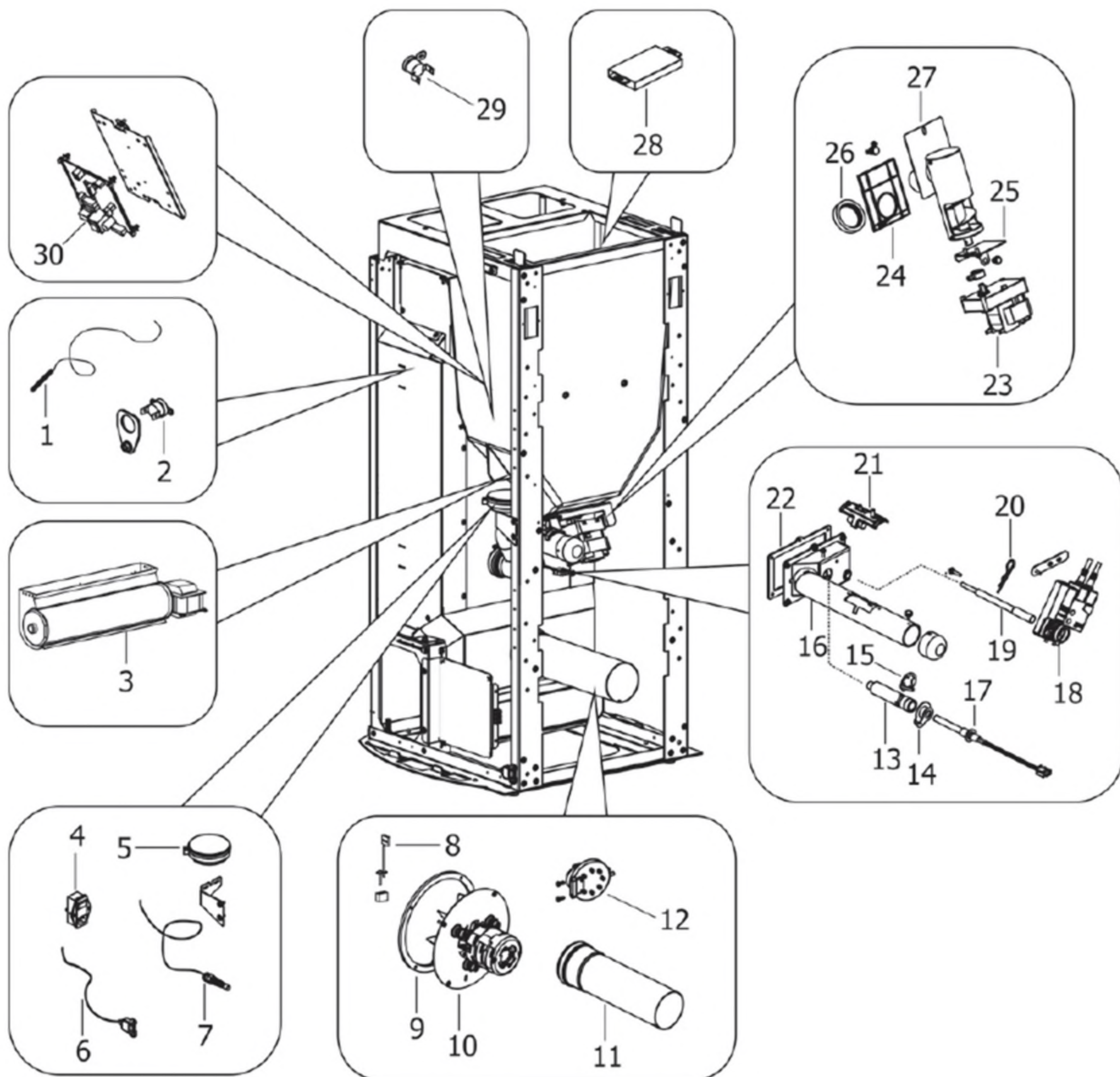

MUSA HYDROMATIC 16 KW

Componenti interni meccanici ed elettronici / Electronic and mechanic internal parts / Interne mechanische und elektronische Bauteile / Composants internes mécaniques et électroniques / Componentes internos electrónicos y mecánicos

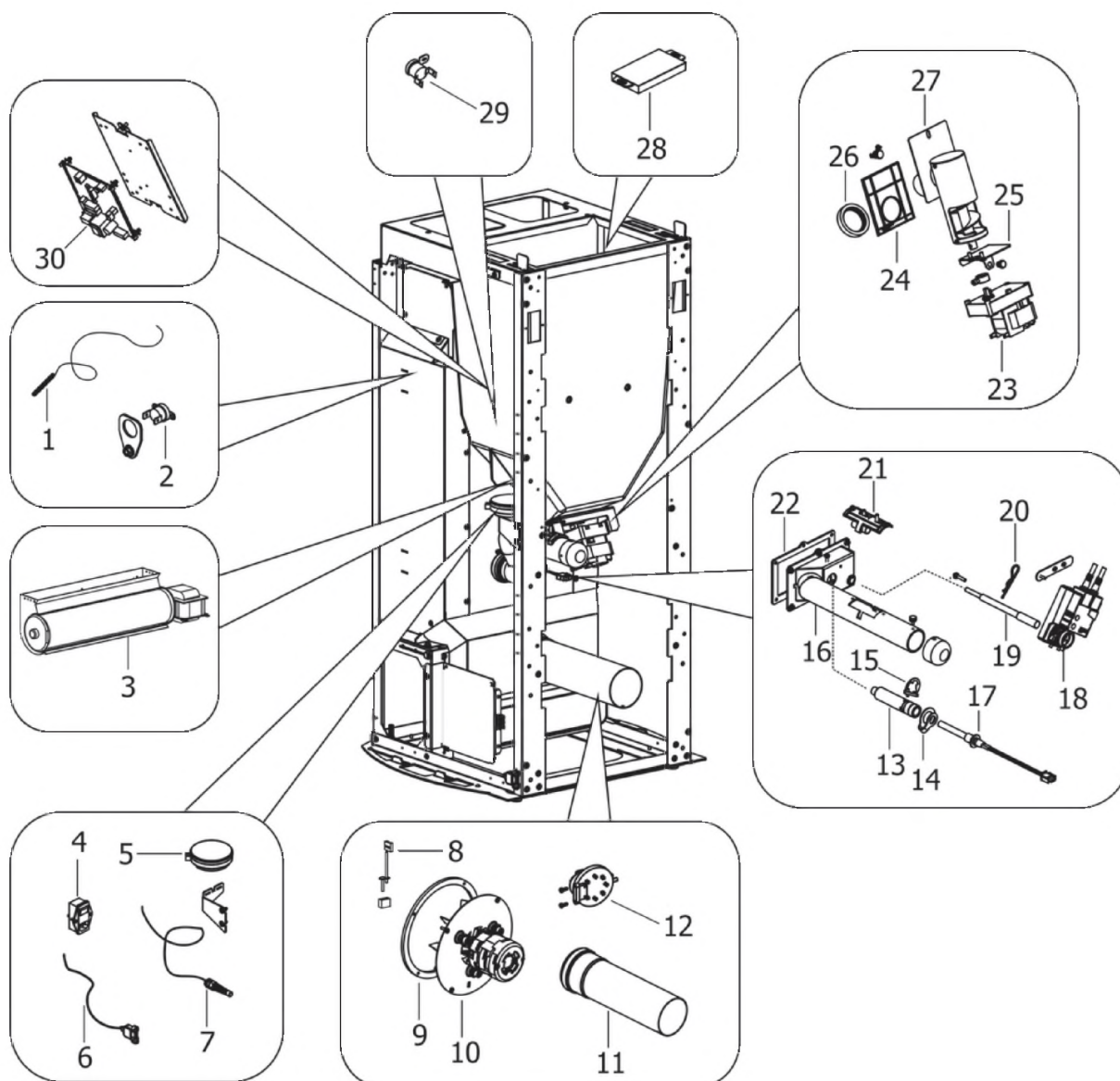

N°	Codice/Code	Descrizioni / Description / Beschreibung / Description / Descripción	Prezzo (€)
1	4012062	Sonda NTC a filo per acqua / Water temperature sensor / Wassertemperaturfühler / Sonde température eau / Sonda temperatura agua	21.00
2	41450901100	Clickson 95°C / Clickson 95°C / Clickson 95°C / Clickson 95°C / Clickson 95°C	20.00
3	41451000300	Ventilatore scambiatore aria calda / Hot air exchanger fan / Wärmeluftgebläse / Ventilateur échangeur air chaud / Ventilador intercambiador aire caliente	55.00
4	4160193	Pulsante accensione / On/Off button / Zündungstaste / Touche d'allumage / Botón encendido	28.00
5	41451303400	Trasduttore di pressione / Pressure transducer / Active-Wandler / Transducteur de pression / Transductor de pression	58.00
6	41451403200	Cavo USB da pannello L.500 / USB Cable from display L.500 / USB Kabel von Notfalldisplay L.500 / Câble USB de panneau L.500 / Cable USB del panel L.500	21.00
7	4160240	Sonda temperatura ambiente / Room temperature sensor / Raumtemperaturfühler / Sonde température ambiance / Sonda temperatura aire	20.00
8	41451404500	Sonda fumi con flangia / Smoke sensor with flange / Rauchsonde mit Flansche / Sonde fumées avec bride / Sonda humos con brida	25.00

9	41801301500	Guarnizione ventilatore fumi / Smoke exhaust fan gasket / Dichtung Rauchabsauggebläse / Joint Ventilateur aspiration fumées / Junta ventilador aspiración humos	20.00
10	41451600100	Ventilatore fumi senza chiocciola stagno / Air-tight smoke exhausted fan / Luftdicht Rauchgasgebläse / Ventilateur fumées étanche / Ventilador humos hermético	210.00
10	41452009200	Encoder ventilatore / Fan encoder / Lüfter Encoder / Encodeur de ventilateur / Codificador de ventilador	17.00
11	41601601160	Tubp fumi a innesto Ø80 con guarnizione / Smoke pipe Ø 80 with gasket / Rauchrohr Ø 80 mit Dichtung / Tuyau fumées Ø 80 avec joint / Tubo humos Ø 80 con junta	29.00
12	4160482	Pressostato 0,4 mbar / Pressure gauge 0,4 mbar / Druckschalter 0,4 mbar / Pressostat 0,4 mbar / Presostato 0,4 mbar	38.00
12	4120631A	Tubicino siliconico - 5m / Silicon tube - 5m / Silikonrohr - 5m / Petit tuyau en silicone - 5m / Tubo silicónico - 5m	22.00
13	41601802700	Condotto candeletta / Sparkplug Conduit / Zündkerzenkanal / Conduit Bougie / Conducto Bujía	36.00
14	41801604300	Guarnizione condotto candeletta / Sparkplug conduit gasket / Dichtung Zündkerzenkanal / Joint conduit bougie / Junta conducto bujía	19.00
15	41201601500	Anello arresto candeletta / Sparkplug stop / Zündkerzestopper / Butée bougie / Tope bujía	24.00
16	41411609140V	Supporto sistema braciere autopulente / Self-cleaning grate support / Selbstreinigend Brennertopf Gestell / Support brasero autonettoyant / Soporte brasero en arrabio autolimpiador	131.00
17	41451308101	Candeletta 315 Watt / Sparkplug 315 Watt / Zündkerze 315 Watt / Bougie 315 Watt / Bujía 315 Watt	77.00
17	41451308150	Kit 25 candelette 315 Watt / 25 Sparkplugs 315 Watt kit / Bausatz 25 Zündkerzen 315 Watt / Kit 25 Bougies 315 Watt / Kit 25 Bujías 315 Watt	1,637.00
18	41451600900	Attuatore rotativo / Actuator / Trieb / Actionneur / Actuador	247.00
19	41201601300	Asse fondo braciere autopulente / Self-cleaning bottom grate shaft / Selbstreinigend Brennertopf Bolzen / Pivot brasero autonettoyant / Perno brasero autolimpiador	38.00
20	41201100300	Copiglia elastica (pz.10) / Splint pin (Pcs.10) / Splint (Stk.10) / Goupille fendue (Pcs.10) / Pasador (Pz.10)	18.00
21	41601305050	Componente rilevamento portata aria / Air flow measure component / Bauteil für Messung der Luftmenge / Composant pour la mesuration de la quantité d'air / Componente por la medida de l'aire	30.00
22	418008027	Guarnizione / Gasket / Dichtung / Joint / Junta	22.00
23	41451204900	Motoriduttore 3,3 RPM / Reduction motor 3,3 RPM / Getriebemotor 3,3 RPM / Motorréducteur 3,3 RPM / Motorreductor 3,3 RPM	108.00
24	41801600400	Guarnizione gruppo caricamento / Gasket / Dichtung / Joint / Junta	20.00
25	41401606430	Staffa fermo motoriduttore / Reduction motor bracket stop / Getriebemotor Bügelstopper / Butée étrier motorréducteur / Tope zuncho motorreductor	21.00
26	41801501900	Guarnizione silicone / Silicon gasket / Silikondichtung / Joint en silicone / Junta en silicóna	20.00
26	41801702600	Disaccoppiatore misc. Marrone / Brown disengaging device / Braun Verängungsrohr / Tuyau de découplage maron / Tubo de desvío marron	18.00
27	41411800151	Gruppo alimentazione completo / Complete feed screw / Komplette Förderschnecke / Vis sans fin complète / Coclea de carga completa	113.00
28	41451303706	Pannello comandi Hottoh 129 / Control panel Hottoh 129 / Bedienblende Hottoh 129 / Tableau de commande Hottoh 129 / Panel de mandos Hottoh 129	163.00
28	41451303600	Cavo connessione pannello / Control panel connection cable / Bedienblende Verbindungskabel / Cable de connection au tableau / Cable de conexión panel de comando	21.00
29	412007004	Clickson 110°C / Clickson 110°C / Clickson 110°C / Clickson 110°C / Clickson 110°C	20.00
30	41451303805	Scheda madre Hottoh 148 / Hottoh motherboard 148 / Hauptplatine Hottoh 148 / Carte mère Hottoh 148 / Tarjeta madre Hottoh 148	170.00
30	41451303807	Scheda madre Hottoh 148 / Hottoh motherboard 148 / Hauptplatine Hottoh 148 / Carte mère Hottoh 148 / Tarjeta madre Hottoh 148	210.00
30	41451601000	Cablaggio completo / Complete wiring / Komplette Verkabelung / Câblage complet / Cableado completo	96.00
30	41451601002	Cablaggio completo / Complete wiring / Komplette Verkabelung / Câblage complet / Cableado completo	102.00
30	41451602300	Cablaggio completo / Complete wiring / Komplette Verkabelung / Câblage complet / Cableado completo	106.00

MCZ GROUP

MUSA HYDROMATIC 16 KW

Gruppo scambiatore / Exchanger group / Austausch Baugruppe / Groupe échangeur / Grupo intercambiador

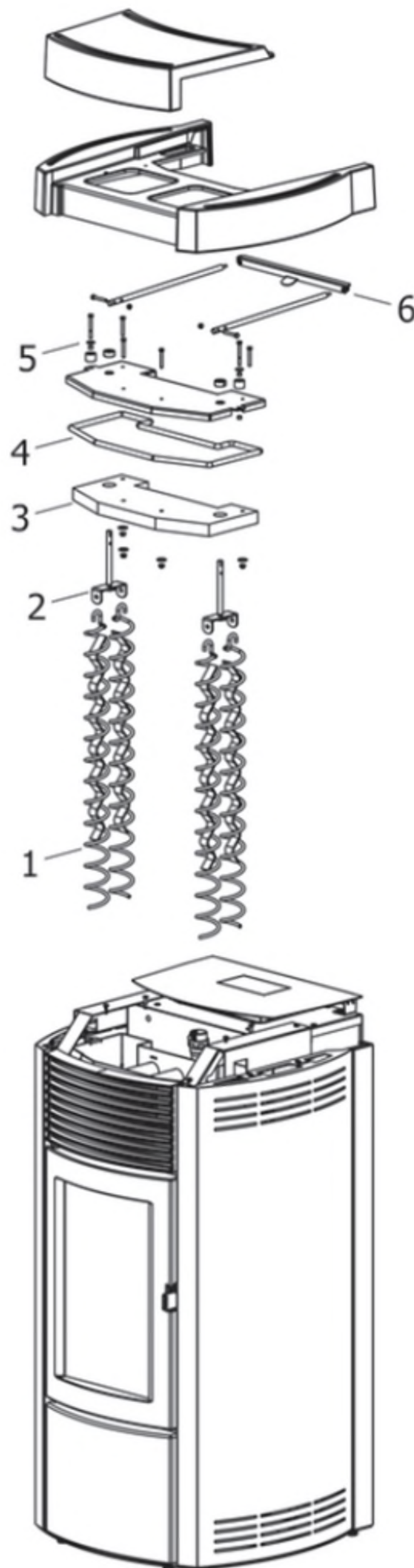

MUSA HYDROMATIC 16 KW

Gruppo scambiatore / Exchanger group / Austausch Baugruppe / Groupe échangeur / Grupo intercambiador

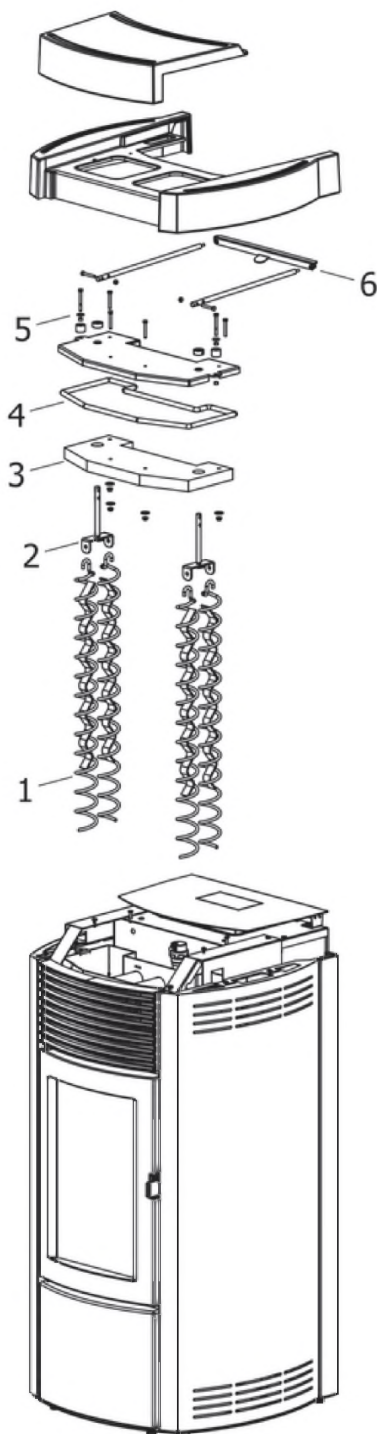

N°	Codice/Code	Descrizioni / Description / Beschreibung / Description / Descripción	Prezzo (€)
1	41400914540	Eliche raschiatore (1 pz.) / Turbulator props (1 pc.) / Propeller des Schabers (1 Teil) / Hélices turbulateur (1 pz.) / Héliche rascador (1 pz.)	41.00
2	41401129341	Staffa sostegno raschiatore Inox / Inox turbulator support bar / Haltebügel des Schabers aus Inox / Etrier support turbulateur en Inox / Zuncho apoyo rascador de Inox	28.00

3	41151600100	Pannello vermiculite coperchio / Vermiculite cover / Deckel aus Vermiculite / Couvercle en vermiculite / Tapa en vermiculite	33.00
4	4120103A	Cordino fibroceramico Ø 10 mm (5 mt.) / Ceramic fibre cord Ø 10 mm (5 m) / Keramikfaserschnur Ø 10 mm (5 m) / Cordon en fibre céramique Ø 10 mm (5 m) / Junta a cuerda de fibra cerámica Ø 10 mm (5 m)	29.00
5	41411608940V	Coperchio struttura caldaia nero / Boiler black cover / Schwarz Kelleldeckel / Couvercle noir chaudière / Tapa negra caldera	70.00
5	41200903300	Trascinatore turbolatori (2 pz.) / Turbolator props puller (2 PC.) / Reinigungsspiralenmitnehmer (2 STCK). / Meneur de turbolateur (2 Pc.) / Arrebatador hélice rascador (2 pz).	25.00
5	41801499550	Kit scarico sovrappressione camera di combustione (pz.2) / Pressure relief kit (Pcs.2) / Bausatz überdruckablauf brennkammer (Stck.2) / Kit decompression chambre combustion (Pcs.2) / Kit descompresion camara combustion (Pcs.2)	25.00
6	41401605430	Traversa leve movimentazione turbolatori / Tturbolator handling crossbeam / Turbolatorstange Träger / Traverse tige turbolateur / Traversa asta rascador	56.00

MCZ GROUP

MUSA HYDROMATIC 16 KW

Componenti interni idraulici **SENZA** kit acqua sanitaria / Internai plumbing components **WITHOUT** domestic water kit / Interne hydraulische Bauteile **OHNE** Brauchwassersatz / Composants hydrauliques internes **SANS** kit eau sanitaire / Componentes internos hidráulicos **SIN** kit de agua sanitaria

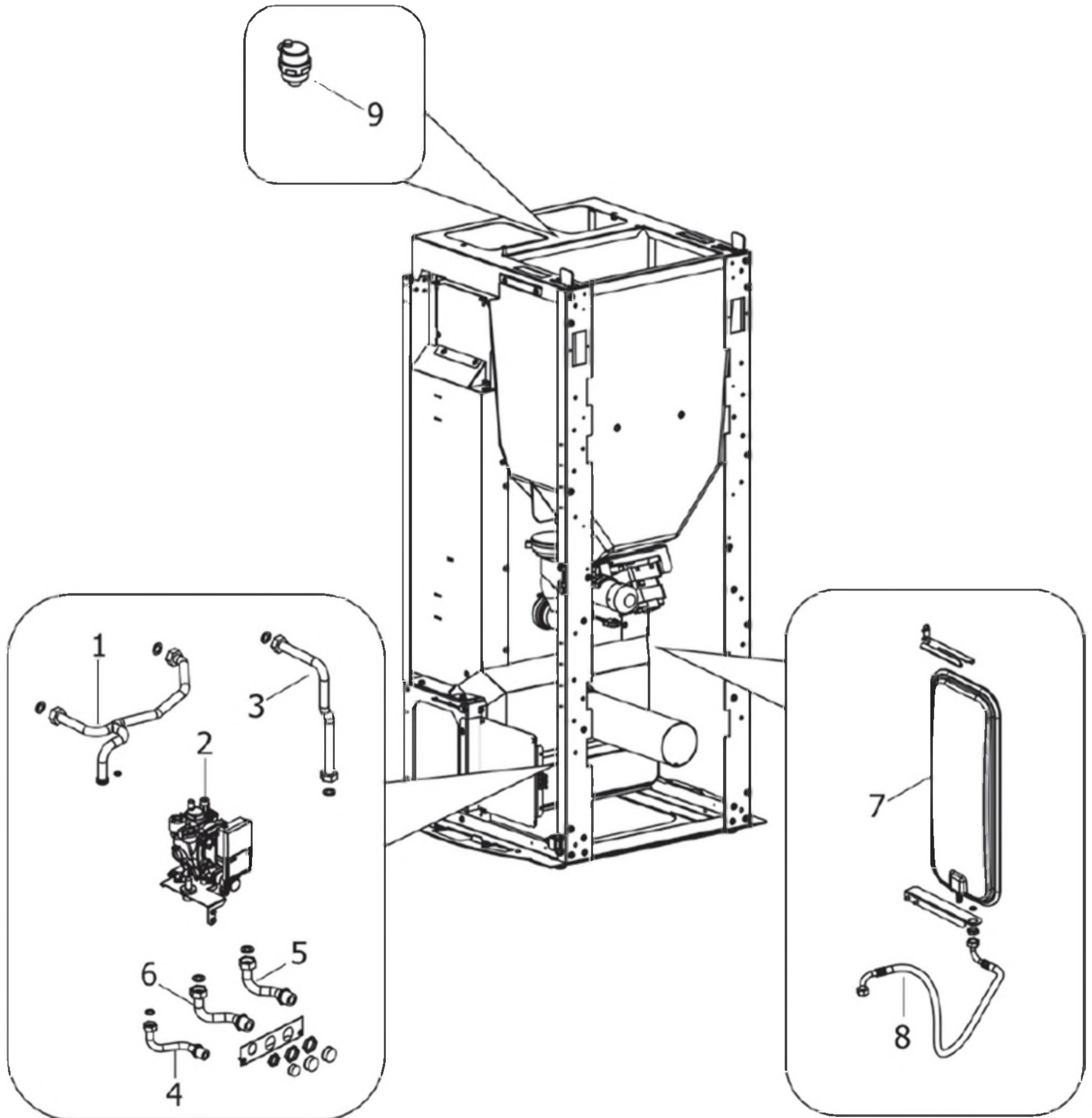

MUSA HYDROMATIC 16 KW

Componenti interni idraulici **SENZA** kit acqua sanitaria / Internal plumbing components **WITHOUT** domestic water kit / Interne hydraulische Bauteile **OHNE** Brauchwassersatz / Composants hydrauliques internes **SANS** kit eau sanitaire / Componentes internos hidráulicos **SIN** kit de agua sanitaria

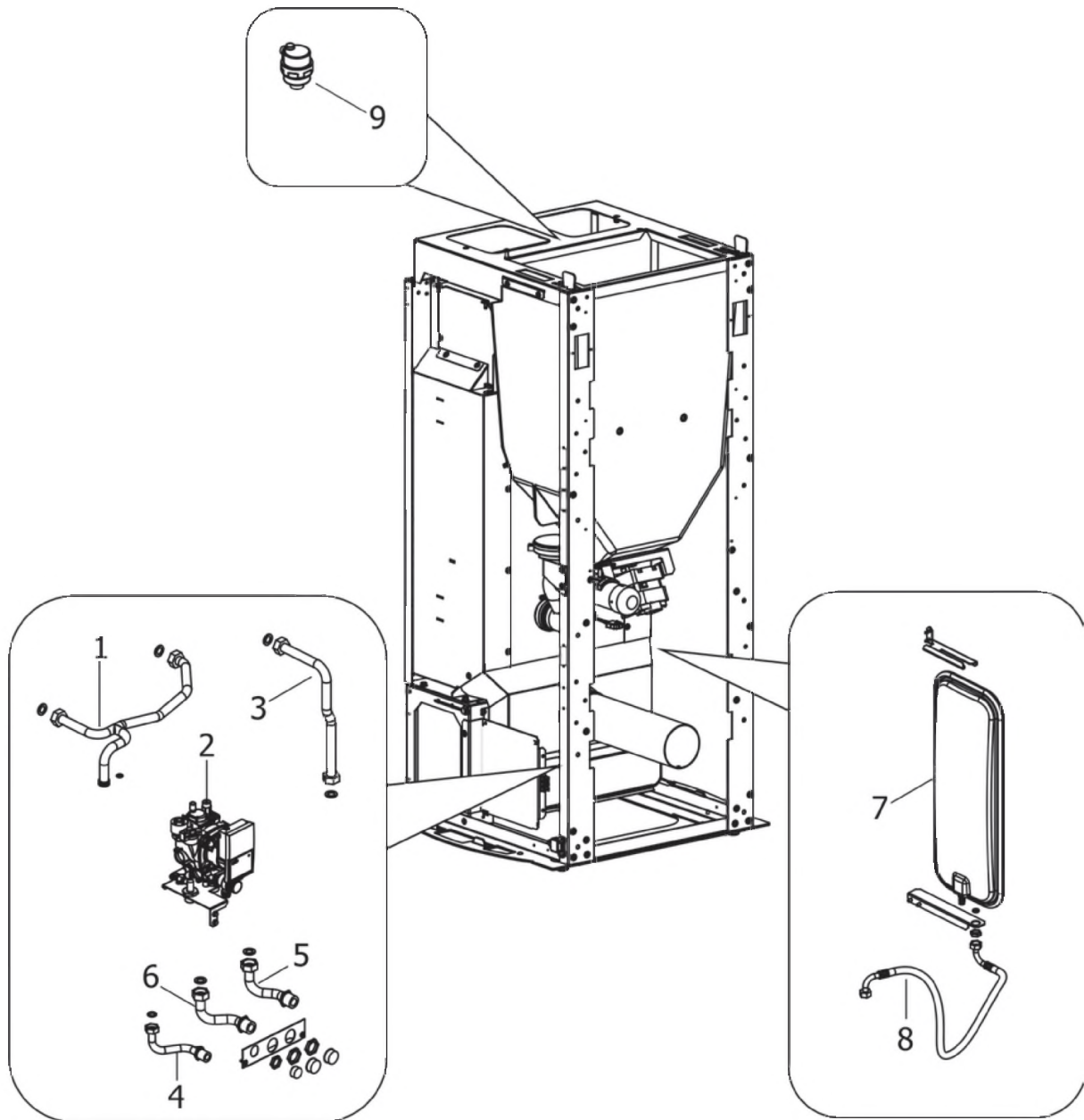

N°	Codice/Code	Descrizioni / Description / Beschreibung / Description / Descripción	Prezzo (€)
1	41501600300	Tubo circolazione caldaia / Boiler circulation tube / Rohr für Kesselumwälzung / Tuyau de circulation chaudière / Tubo de circulación caldera	58.00
2	41501600250	Kit idraulico pompa Wilo Yonos Para alta efficienza / Hydraulic kit high efficiency pump Wilo Yonos Para / Hydraulische Baugruppe hoch Effizienz Pumpe Wilo Yonos Para / Kit hydraulique pompe de circulation Wilo Yonos Para haut rendement / Kit fontanero bomba circulación Wilo Yonos Para alto rendimiento	-
2	41451108000	Pressostato di minima H2O / Pressur switch H2O / Druckwächter H2O / Pressostat H2O / Presostato H2O	31.00
2	41501103300	Valvola di sicurezza 3 Bar / Maximum pressure valve 3 Bar / Sicherheitsventil 3 Bar / Soupape de pression maximale 3 Bar / Válvula máxima presión 3 Bar	32.00
2	41801204500	Forcella tubo ø18 / Fork pipe ø18 / Gabel-Rohr ø18 / Fourche je roucoule ø18 / Horquilla arrollo ø18	21.00
2b	41501600251	Kit idraulico pompa Wilo Para alta efficienza / Hydraulic kit high efficiency pump Wilo Para / Hydraulische Baugruppe hoch Effizienz Pumpe Wilo Para / Kit hydraulique pompe de circulation Wilo Para haut rendement / Kit fontanero bomba circulación Wilo Para alto rendimiento	302.00

2b	41502002100	Circolatore Wilo Para 7 IPWM / Water circulation pump Wilo Para 7 IPWM / Umwälzpumpe Wilo Para 7 IPWM / Pompe de circulation Wilo Para 7 IPWM / Bomba de circulación agua Wilo Para 7 IPWM	314.00
3	41501600600	Tubo mandata impianto / Delivery tube / Vorlaufrohr / Tuyau refoulement / Tubo de envío	44.00
4	41501600400	Tubo di carico caldaia / Boiler loading tube / Rohr für Kesselbefüllung / Tuyau de chargement chaudière / Tubo de carga caldera	35.00
5	41501600700	Raccordo mandata impianto / Delivery tube connection / Vorlaufrohr Verbindung / Raccord tuyau refoulement / Raccor tubo de envío	38.00
6	41501600500	Tubo ritorno impianto / Return tube / Rücklaufrohr / Tuyau retour / Tubo de regreso	38.00
7	4120775	Vaso espansione (6 l) / Expansion vessel (6 l) / Expansionsgefäß (6 l) / Vase d'expansion (6 l) / Vaso de expansion (6 l)	75.00
8	41501601000	Tubo flessibile L.600 / Flexible tube L.600 / Flexibles Rohr L.600 / Tuyau flexible L.600 / Tubo flexible L.600	29.00
9	4120779	Valvola di sfiato / Vent valve / Entlüftungsventil / Soupape de dégagement / Válvula respiradero	26.00