

ECO 15/2 Cod. 00841293
ECO 20/2 Cod. 00840743
TAV. 402-2

Luglio 2010

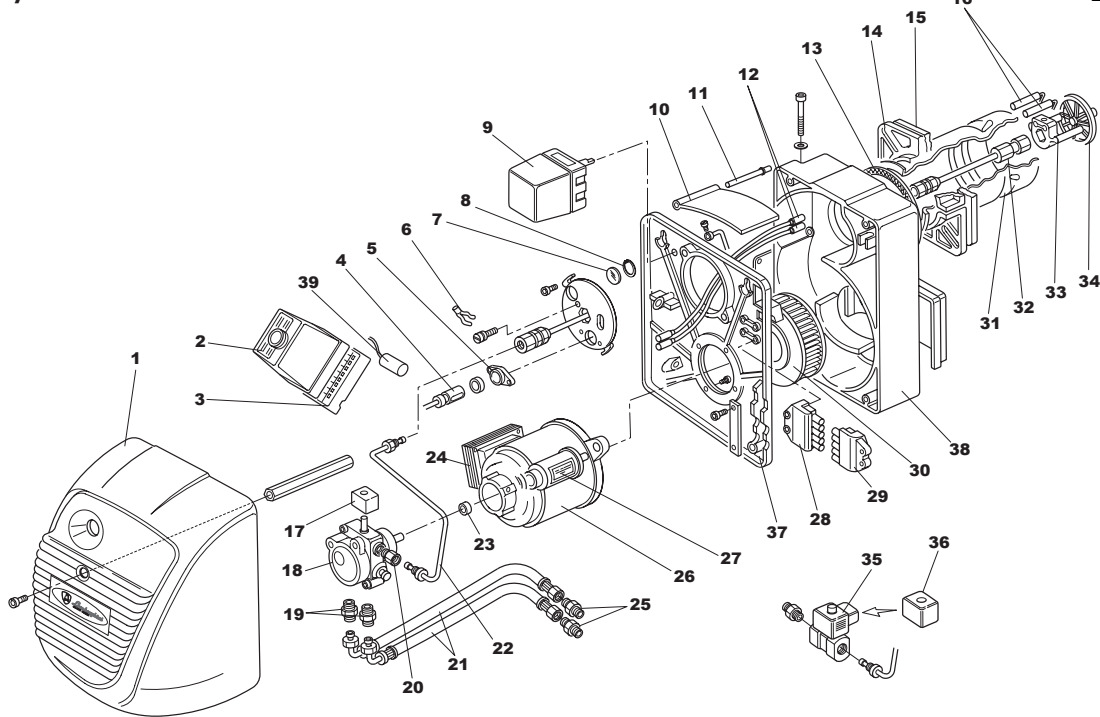

Pos.	Cod.	Denominazione	Denomination	Denomination	Denominación
1	1.13775.0	Cofano	Cover	Capot	Tapa
2	4.04207.0	App. Landis LMO 24	Control box	Coffret de sécurité	Programador
3	4.01551.0	Zoccolo	Base	Base	Base
4	4.03644.0	Fotoresistenza	Photocell	Photorésistance cellule	Fotoresistencia
5	4.03642.0	Supporto fotoresistenza	Photoresistor holder	Support photorésistance	Suporte fotoresistencia
6	1.11865.0	Molla raccordo mandata	Delivery coupling spring	Ressort du raccord départ	Muelle racor ida
7	1.11871.0	Vetrino ispezione	Ispection window	Viseur de flamme	Mirilla de inspección
8	3.00125.0	Anello seeger	Seeger	Seeger	Seeger
9	8.01899.0	G/Motoriduttore +cavo	Air aperture servomotor	Sevomoteur ouverture de l'air	Servomotor mando apertura aire
10	1.11893.0	Bandella aria	Air flap	Clapet d' air	Palomilla
11	1.12283.0	Perno bandella	Air flap shaft	Arbre clapet air	Arbol palomilla aire
12	1.13760.0	Cavo elettrodo	Electrode cable	Cable èlectrode	Cable electrodo
13	1.11887.0	Guarnizione boccaglio	Draught tube gasket	Guelard joint	junta boca de fuego
14	1.11880.0	Flangia attacco caldaia	Boiler connecting flange	Flange connexion chaudière	Brida de fijación a la caldera
15	1.11881.0	Guarnizione isolante	Insulating gasket	Joint isolant	Junta aislante
16	4.04031.0	Elettrodi	Electrode	E'lectrode	Electrodo
17	4.01870.0	Bobina SUNTEC	Coil	Bobine	Bobine
18	4.03879.0	Pompa SUNTEC	Pump	Pompe	Bomba
19	1.05802.0	Nipallo 1/4"	Pump coupling 1/4"	Raccord pompe 1/4"	Racor bomba 1/4"
20	1.11875.0	Raccordo tubo mandata	Delivery tube coupling	Raccord conduit de départ	Racor tubo ida
21	1.06922.0	Flessibile	Hose	Flexible	Flexible
22	1.11912.0	Tubo mandata	Feeding tube	Ligne alimentation	Tubo alimentacion
23	4.03646.0	Giunto motore	Joint motor	Joint du moteur	Junta motor
24	4.04416.0	Trasformatore	Transformer	Transformateur	Transformador
25	1.00119.0	Nipallo 3/8"	Flex coupling 3/8"	Raccord flexible 3/8"	Racor flexible 3/8"
26	1.11895.0	Motore 185 W (ACC)	Motor	Moteur	Motor
	1.13686.0	Motore 185 W (SIMEL)	Motor	Moteur	Motor
27	4.03801.0	Condensatore	Condensor	Condensateur	Condensador
28	4.03422.0	Presa 7 poli	7 pole socket	Prise 7 pôles	Conector 7 polos
29	4.03210.0	Spina 7 poli	7 pole plug	Fiche 7 pôles	Conector 7 polos
30	4.03713.0	Ventola	Fan	Ventilateur	Turbina
31	1.11914.0	Boccaglio ECO 15/2	Draught tube	Guelard	Boca de fuego
	1.11921.0	Boccaglio ECO 20/2	Draught tube	Guelard	Boca de fuego
32	1.11915.0	Supporto gicleur	Nozzle holder	Support gicleur	Linea inyector
33	1.11876.0	Supporto elettrodi	Electrodes holder	Support électrodes	Soporte electrodos
34	1.11888.0	Disco deflettore	Deflector	Deflector	Deflector
35	4.03669.0	VE. PARKER VE 131 AN	Solenoid valve	Electrovanne	Electrovalvula
36	4.03761.0	Bobina	Coil	Bobine	Bobine
37	1.12291.0	Piastra componenti	Components' plate	Plaque composantes	Placa componentes
38	1.12286.0	Corpo bruciatore	Burner body	Corps du brûleur	Cuerpo quemador
39	4.04116.0	Filtro antisturbo	Antijamming filter	Filtre antiparasite	Filtro antiparasitario