

VEGA/VEGA GH/VEGA SL AT/VEGA AIRTIGHT

Componenti Struttura Esterna METAL / Componenti Struttura Esterna METAL / Componenti Struttura Esterna METAL / Componenti Struttura Esterna METAL / Componenti Struttura Esterna METAL

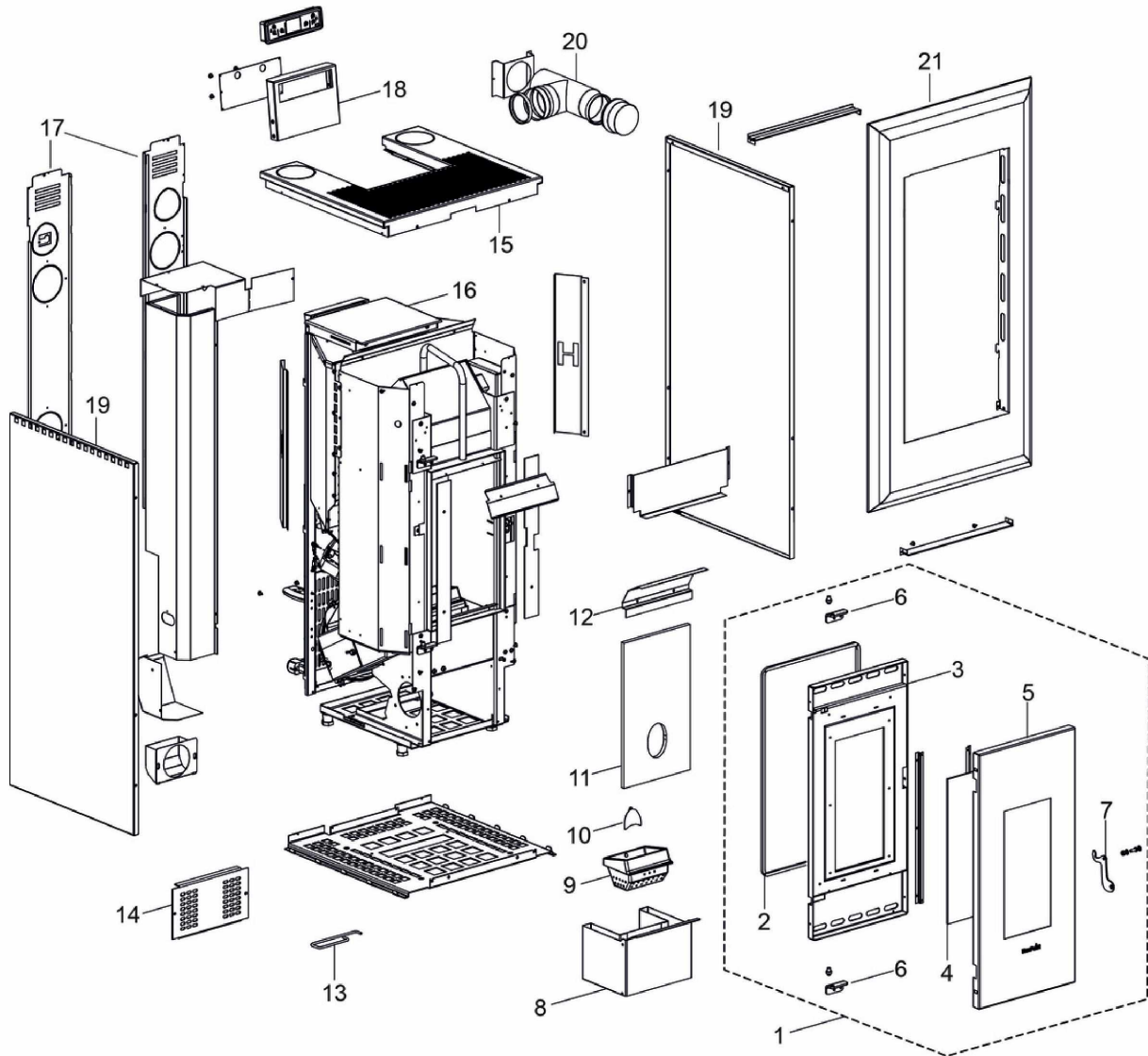

N°	Codice/Code	Descrizioni / Description / Beschreibung / Description / Descripción	Prezzo (€)
1	4D245GP16001	Porta fuoco completa in ghisa / Cast iron complete fire door / Komplette Feuertür aus Guß / Porte foyer complète en fonte / Puerta hogar completa de arrabio	200.00
2	4D18013021A	Guarnizione treccia nera D.10 - 5 M / Black twist gasket D.10 - 5 M / Dichtung D.10 - 5 M / Joint tresse noire D.10 - 5 M / Junta D.10 - 5 M	33.00
2	4D18013021B	Guarnizione treccia nera D.10 - 50 M / Black twist gasket D.10 - 50 M / Dichtung D.10 - 50 M / Joint tresse noire D.10 - 50 M / Junta D.10 - 50 M	144.00
3	4D24014064461	Telaio porta fuoco / Fire door frame / Feuertürrahmen / Cadre porte foyer / Armazón puerta hogar	122.00
4	4D170140010	Vetroceramico 385x175x4 mm / Glass 385x175x4 mm / Glasskeramikscheibe 385x175x4 mm / Vitrocéramique 385x175x4 mm / Cristal cerámico 385x175x4 mm	77.00
4	4D170157040	Vetroceramico 379x193x4 / Ceramic glass 379x193x4 / Glaskeramikscheibe 379x193x4 / Vitrecéramique 379x193x4 mm / Cristal cerámico 379x193x4 mm	106.00
5	4D24014048361	Telaio porta esterna / External door frame / Außentürrahmen / Cadre porte extérieure / Armazón puerta exterior	80.00
5	4D13015701061	Telaio porta fuoco in ghisa / Cast iron fire door frame / Feuertürrahment aus Guß / Cadre porte foyer en fonte / Armazón puerta hogar de arrabio	172.00
6	4D2401303720	Supporto porta nero / Black door support / Schwarzes Türhaltebügel / Support porte noir / Soporte puerta negro	21.00
6	4D2401303720	Supporto porta nero / Black door support / Schwarzes Türhaltebügel / Support porte noir / Soporte puerta negro	21.00
7	4D24014066161	Maniglia / Handle / Griff / Poignée / Tirador	23.00

7	4D24015868161	Maniglia / Handle / Griff / Poignée / Tirador	26.00
7	4D24015841361	Kit decompressione camera di combustione / Pressure relief kit / Bausatz Überdruckablauf Brennkammer / Kit decompression chambre de combustion / Kit decompression cámara de combustión	32.00
8	4D24014015461	Cassetto cenere / Ash drawer / Aschenkasten / Tiroir à cendres / Cajón ceniza	84.00
9	413008003	Braciere completo in ghisa / Cast iron complete grate / Kompletter Brennertopf aus Gusseisen / Brasero complet en fonte / Brasero completo de arrabio	67.00
9	4D13016602061	Braciere / Grate / Brennschale / Brasero / Brasero	62.00
10	4D2401303101	Deflettore pellet / Pellet deflector / Pellet Leitblech / Deflecteur pellet / Deflector pellet	34.00
11	4D115140020	Schiena in Calorite (2pz) / Calorite back (2 Pcs) / Rückwand aus Calorite (2 Stk) / Fond en Calorite (2 Pcs) / Parte trasera de Calorite (2 Pz)	49.00
12	4D242140043	Supporto Vermiculite / Vermiculite support / Vermiculite Halterung / Support Vermiculite / Soporte Vermiculite	27.00
13	4D12013060	Gancio "Mano fredda" / Hook "Cold hand" / Haken "Kalte Hand" / Crochet "Main froide" / Gancho "mano fría"	21.00
14	4D24014028363	Frontalino inferiore / Lower filler / Untere Stopfung / Plaque inférieure / Tapa inferior	36.00
15	4D24014044361	Top nero / Black top / Schwarze Topplatte / Dessus noir / Top negro	122.00
16	4D18013016	Guarnizione 155X190 mm / Gasket 155X190 mm / Dichtung 155x190 mm / Joint 155X190 mm / Junta 155X190 mm	34.00
16	4D24014020361	Coperchio serbatoio pellet / Pellet hopper cover / Deckel Pelletbehälter / Couvercle réservoir pellet / Tapadera depósito	48.00
17	4D241140223	Tamponazione posteriore / Rear filler / Hintere Stopfung / Plaque postérieure / Tapa posterior	54.00
18	4D24014033363	Supporto pannello comandi / Display support / Display halterung / Support pour le panneau de commande / Soporte panel de mandos	32.00
19	4D24014045363	Fianco nero / Black side / Schwarze Seite / Côté noir / Lateral negro	104.00
19	4D24014045363	Fianco nero / Black side / Schwarze Seite / Côté noir / Lateral negro	104.00
20	4D160140070	Raccordo a "T" + Guarnizione / T-Union + Gasket / T-Stück + Dichtung / Raccord en "T" + joint / Tuvería en te + Junta	51.00
21	6913091	Rivestimento completo Rosso / Complete Red cladding / Komplette Verkleidung Rot / Habillage complète Rouge / Revestimiento completo Rojo	90.00
21	6913092	Rivestimento completo Bianco / Complete White cladding / Komplette Verkleidung Weiß / Habillage complète Blanc / Revestimiento completo Blanco	90.00
21	6913093	Rivestimento completo Antracite / Complete Charcoal cladding / Komplette Verkleidung Anthrazit / Habillage complète Antracite / Revestimiento completo Antracita	90.00
21	6915007	Rivestimento completo metallo Moka / Complete Moka metal cladding / Komplette Verkleidung Metall Moka / Habillage complète métal Moka / Revestimiento completo metal Moka	90.00

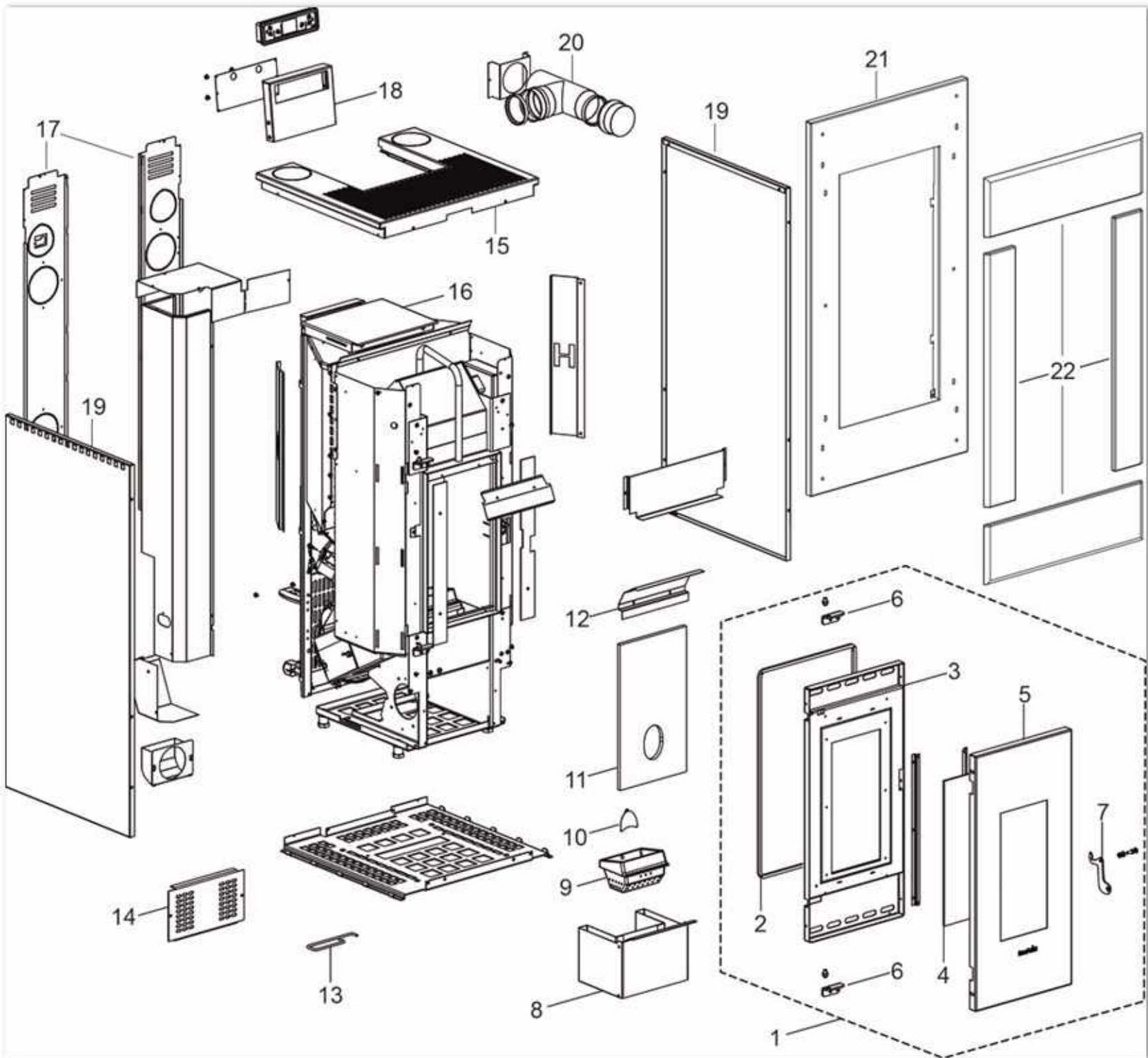

VEGA/VEGA GH/VEGA SL AT/VEGA AIRTIGHT

Componenti Struttura Esterna STONE / Componenti Struttura Esterna STONE / Componenti Struttura Esterna STONE / Componenti Struttura Esterna STONE / Componenti Struttura Esterna STONE

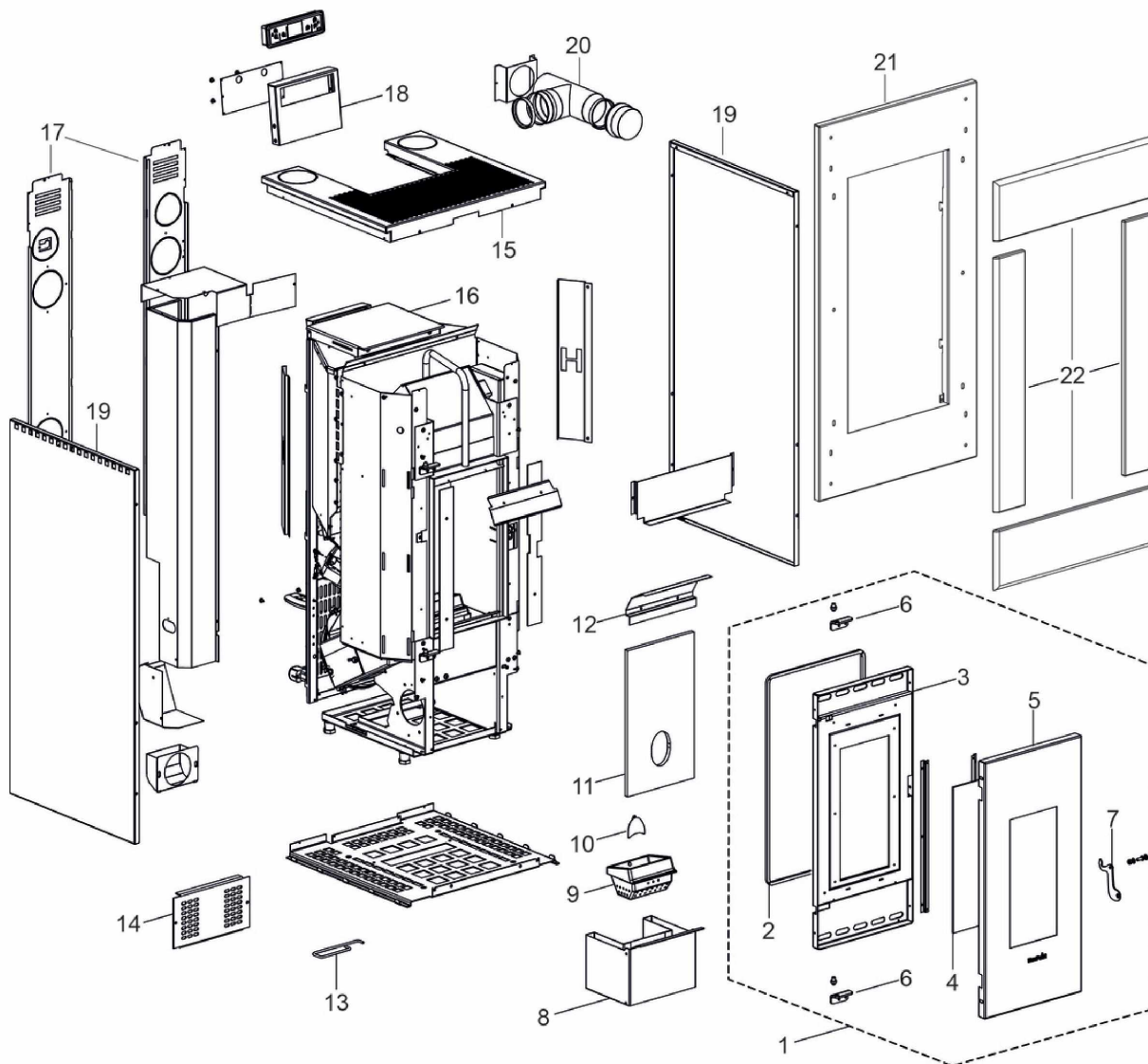

N°	Codice/Code	Descrizioni / Description / Beschreibung / Description / Description	Prezzo (€)
1	4D245GP16001	Porta fuoco completa in ghisa / Cast iron complete fire door / Komplette Feuertür aus Guß / Porte foyer complète en fonte / Puerta hogar completa de arrabio	200.00
2	4D18013021A	Guarnizione treccia nera D.10 - 5 M / Black twist gasket D.10 - 5 M / Dichtung D.10 - 5 M / Joint tresse noire D.10 - 5 M / Junta D.10 - 5 M	33.00
2	4D18013021B	Guarnizione treccia nera D.10 - 50 M / Black twist gasket D.10 - 50 M / Dichtung D.10 - 50 M / Joint tresse noire D.10 - 50 M / Junta D.10 - 50 M	144.00
3	4D24014064461	Telaio porta fuoco / Fire door frame / Feuertürrahmen / Cadre porte foyer / Armazón puerta hogar	122.00
4	4D170140010	Vetroceramico 385x175x4 mm / Glass 385x175x4 mm / Glasskeramikscheibe 385x175x4 mm / Vitrocéramique 385x175x4 mm / Cristal cerámico 385x175x4 mm	77.00
4	4D170157040	Vetroceramico 379X193X4 / Ceramic glass 379X193X4 / Glaskeramikscheibe 379X193X4 / Vitrecéramique 379x193x4 mm / Cristal cerámico 379x193x4 mm	106.00
5	4D24014048361	Telaio porta esterna / External door frame / Außentürrahmen / Cadre porte extérieure / Armazón puerta exterior	80.00
5	4D13015701061	Telaio porta fuoco in ghisa / Cast iron fire door frame / Feuertürrahment aus Guß / Cadre porte foyer en fonte / Armazón puerta hogar de arrabio	172.00
6	4D2401303720	Supporto porta nero / Black door support / Schwarzes Türhaltebügel / Support porte noir / Soporte puerta negro	21.00
6	4D2401303720	Supporto porta nero / Black door support / Schwarzes Türhaltebügel / Support porte noir / Soporte puerta negro	21.00
7	4D24014066161	Maniglia / Handle / Griff / Poignée / Tirador	23.00

7	4D24015868161	Maniglia / Handle / Griff / Poignée / Tirador	26.00
7	4D24015841361	Kit decompressione camera di combustione / Pressure relief kit / Bausatz Überdruckablauf Brennkammer / Kit decompression chambre de combustion / Kit decompression cámara de combustión	32.00
8	4D24014015461	Cassetto cenere / Ash drawer / Aschenkasten / Tiroir à cendres / Cajón ceniza	84.00
9	413008003	Braciere completo in ghisa / Cast iron complete grate / Kompletter Brennertopf aus Gusseisen / Brasero complet en fonte / Brasero completo de arrabio	67.00
9	4D13016602061	Braciere / Grate / Brennschale / Brasero / Brasero	62.00
10	4D2401303101	Deflettore pellet / Pellet deflector / Pellet Leitblech / Deflecteur pellet / Deflector pellet	34.00
11	4D115140020	Schiena in Calorite (2pz) / Calorite back (2 Pcs) / Rückwand aus Calorite (2 Stk) / Fond en Calorite (2 Pcs) / Parte trasera de Calorite (2 Pz)	49.00
12	4D242140043	Supporto Vermiculite / Vermiculite support / Vermiculite Halterung / Support Vermiculite / Soporte Vermiculite	27.00
13	4D12013060	Gancio "Mano fredda" / Hook "Cold hand" / Haken "Kalte Hand" / Crochet "Main froide" / Gancho "mano fría"	21.00
14	4D24014028363	Frontalino inferiore / Lower filler / Untere Stopfung / Plaque inférieure / Tapa inferior	36.00
15	4D24014044361	Top nero / Black top / Schwarze Topplatte / Dessus noir / Top negro	122.00
16	4D18013022	Guarnizione 230X160 mm / Gasket 230X160 mm / Dichtung 230x160 mm / Joint 230X160 mm / Junta 230X160 mm	34.00
16	4D24014020361	Coperchio serbatoio pellet / Pellet hopper cover / Deckel Pelletbehälter / Couvercle réservoir pellet / Tapadera depósito	48.00
17	4D241140223	Tamponazione posteriore / Rear filler / Hintere Stopfung / Plaque postérieure / Tapa posterior	54.00
18	4D24014033363	Supporto pannello comandi / Display support / Display halterung / Support pour le panneau de comande / Soporte panel de mandos	32.00
19	4D24014045363	Fianco nero / Black side / Schwarze Seite / Côté noir / Lateral negro	104.00
19	4D24014045363	Fianco nero / Black side / Schwarze Seite / Côté noir / Lateral negro	104.00
20	4D160140070	Raccordo a "T" + Guarnizione / T-Union + Gasket / T-Stück + Dichtung / Raccord en "T" + joint / Tuvería en te + Junta	51.00
21	6915006	Rivestimento completo pietra serpentino / Complete serpentine stone cladding / Komplette Verkleidung naturstein Serpentino / Habillage complète pierre Serpentin / Revestimiento completo piedra serpentino	340.00
22	6915006	Rivestimento completo pietra serpentino / Complete serpentine stone cladding / Komplette Verkleidung naturstein Serpentino / Habillage complète pierre Serpentin / Revestimiento completo piedra serpentino	340.00

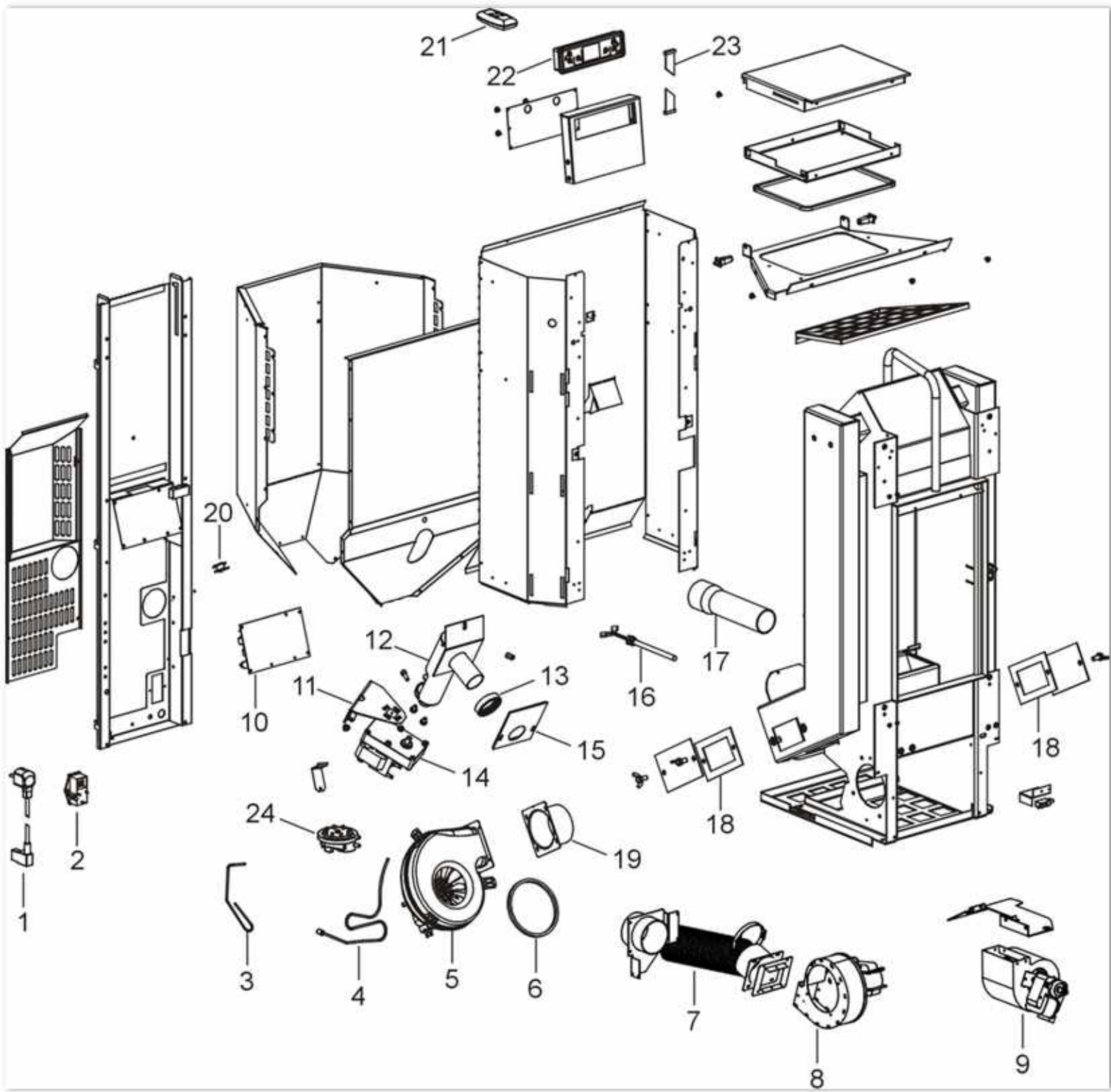

VEGA/VEGA GH/VEGA SL AT/VEGA AIRTIGHT

Componenti interni meccanici ed elettronici fino al SN 2103306010019 / Electrical and mechanic internal parts up to SN 2103306010019 / Interne elektrische und mechanische Bautaile bis zur SN 2103306010019 / Composants internes électriques et mécaniques jusqu'au NS 2103306010019 / Componentes internos electrónicos y mecánicos hasta NS 2103306010019

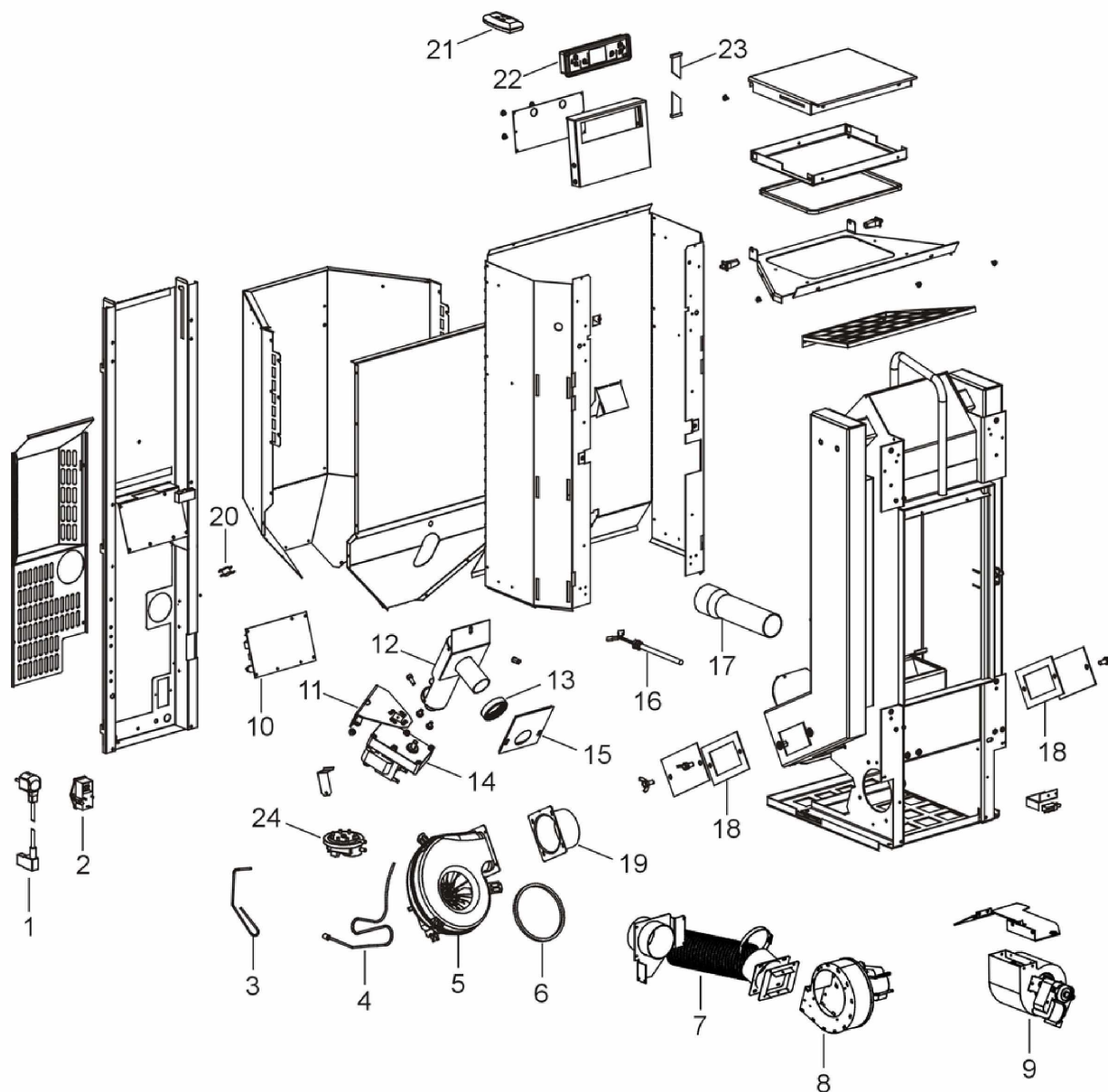

N°	Codice/Code	Descrizioni / Description / Beschreibung / Description / Descripción	Prezzo (€)
1	4D14513041	Cavo alimentazione / Power source cable / Zündungskabel / Câble alimentation / Cable alimentación	25.00
2	4160193	Pulsante accensione / On/Off button / Zündungstaste / Touche d'allumage / Botón encendido	28.00
2	4D145181080	Pulsante accensione 30.5x50 mm / On/Off button 30.5x50 mm / Zündungstaste 30.5x50 mm / Touche d'allumage 30.5x50 mm / Botón encendido 30.5x50 mm	18.00
3	4D145150090	Sonda fumi / Smoke sensor / Rauchsonde / Sonde fumées / Sonda humos	28.00
4	4D145150110	Sonda ambiente / Room temperature sensor / Raumtemperaturfühler / Sonde température ambiance / Sonda ambiente	23.00
5	4D145140150	Ventilatore fumi stagno / Air-tight smoke exhausted fan / Luftdichtes Rauchgasgebläse / Ventilateur fumées étanche / Ventilador humos hermético	121.00
5	41801600800	Guarnizione ventilatore fumi / Smoke exhaust fan gasket / Dichtung Rauchabsauggebläse / Joint Ventilateur aspiration fumées / Junta ventilador aspiración humos	22.00
5	41451209300	Encoder per ventilatore fumi marchi LN2/SIT / Encoder for LN2/SIT smoke fan / Encoder für LN2/SIT Rauchgasgebläse / Encoder pour ventilateur des fumées marques LN2/SIT / Encoder para ventilador humos marcas	21.00

		LN2/SIT	
6	4D18013024	Guarnizione / Gasket / Dichtung / Joint / Junta	26.00
7	4D160140060	Tubo flessibile alluminio D.80 L.200 mm / Flexible aluminium hose D.80 L.200 mm / Aluflexrohr D.80 L.200 mm / Tuyau flexible en aluminium D.80 L.200 mm / Tubo flexible en aluminio D.80 L.200 mm	23.00
8	4D145201070	Ventilatore aria / Air fan / Luftgebläse / Ventilateur air / Ventilador aire	91.00
9	4D14513054	Ventilatore aria / Air fan / Luftgebläse / Ventilateur air / Ventilador aire	114.00
9	4D145198020	Ventilatore aria / Air fan / Luftgebläse / Ventilateur air / Ventilador aire	78.00
10	4D14513064	Scheda madre / Motherboard / Hauptplatine / Carte mère / Tarjeta madre	233.00
10	4D14513064B	Scheda madre / Motherboard / Hauptplatine / Carte mère / Tarjeta madre	233.00
10	4D145185010A	Scheda madre O047 / Motherboard O047 / Hauptplatine O047 / Carte mère O047 / Tarjeta madre O047	203.00
11	4D2401302613	Supporto coclea / Feed screw support / Schnecke Halterung / Support de la vis-sans-fin / Soporte cóclea	37.00
12	4D140160030	Coclea di caricamento pellet / Pellet feed screw / Pelletsförderschnecke / Vis sans fin pour chargement du pellet / Cóclea de carga pellet	163.00
12	4D180177070	Coclea di caricamento pellet / Pellet feed screw / Pelletsförderschnecke / Vis sans fin pour chargement du pellet / Cóclea de carga pellet	141.00
12	4D180177010	Boccola / Bushing / Buchse / Douille / Abrazadera	23.00
13	4D18013003	Guarnizione D.50 mm / Gasket D.50 mm / Dichtung D.50 mm / Joint D.50 mm / Junta D.50 mm	26.00
14	4D145159010	Motoriduttore 3,3 rpm / Reduction motor 3,3 rpm / Getriebemotor 3,3 rpm / Motorréducteur 3,3 rpm / Motorreductor 3,3 rpm	120.00
14	4D145181020	Motoriduttore 2 rpm / Reduction motor 2 rpm / Getriebemotor 2 rpm / Motorréducteur 2 rpm / Motorreductor 2 rpm	107.00
15	4D18013004	Guarnizione 100X108 mm / Gasket 100X108 mm / Dichtung 100x108 mm / Joint 100X108 mm / Junta 100X108 mm	28.00
16	4D14513002	Candeletta / Sparkplug / Zündkerze Pelletzündung / Bougie / Bujía encendido pellet	50.00
16	4D145181040	Candeletta / Sparkplug / Zündkerze / Bougie / Bujía	51.00
17	4D160140040	Tubo ingresso aria 60x2x210 mm / Air inlet pipe 60x2x210 mm / Lufteingangsrohr 60x2x210 mm / Tuyau entrée air 60x2x210 mm / Tubo entrada aire D.80 L.200 mm	30.00
18	4D18013001	Guarnizione 130x80 mm / Gasket 130x80 mm / Dichtung 130x80 mm / Joint 130x80 mm / Junta 130x80 mm	26.00
18	4D18013001	Guarnizione 130x80 mm / Gasket 130x80 mm / Dichtung 130x80 mm / Joint 130x80 mm / Junta 130x80 mm	26.00
19	4D14513040	Raccordo D.80 mm / Connector D.80 mm / Anschlußrohr D.80 mm / Raccord D.80 mm / Racor D.80 mm	22.00
20	4D14513006	Termostato 60°C / Thermostat 60°C / Thermostat 60°C / Thermostat 60°C / Termostato 60°C	48.00
21	5019012	Telecomando / Remote control / Fernbedienung / Télécommande / Mando a distancia	55.00
22	4D14513032	Pannello comandi / Control panel / Bedienblende / Tableau de commande / Panel de mandos	114.00
22	4D1451303300	Pannello comandi grafico / Graphic control panel / Graphische Bedienblende / Tableau de commande / Panel de mandos gráfico	138.00
23	4D14513007	Cavo flat scheda-pannello / Flat cable motherboard-control panel / Flat Kabel Hauptplatine-Bedienblende / Câble flat carte mère-panneau commande / Cable flat tarjeta madre-panel de mandos	31.00
24	4160482	Pressostato 0,4 mbar / Pressure gauge 0,4 mbar / Druckwächter 0,4 mbar / Pressostat 0,4 mbar / Presostato 0,4 mbar	38.00
25	4D241140013	Carter posteriore / Back carter / Hinteres Blech / Protection arrière / Carter trasero	71.00

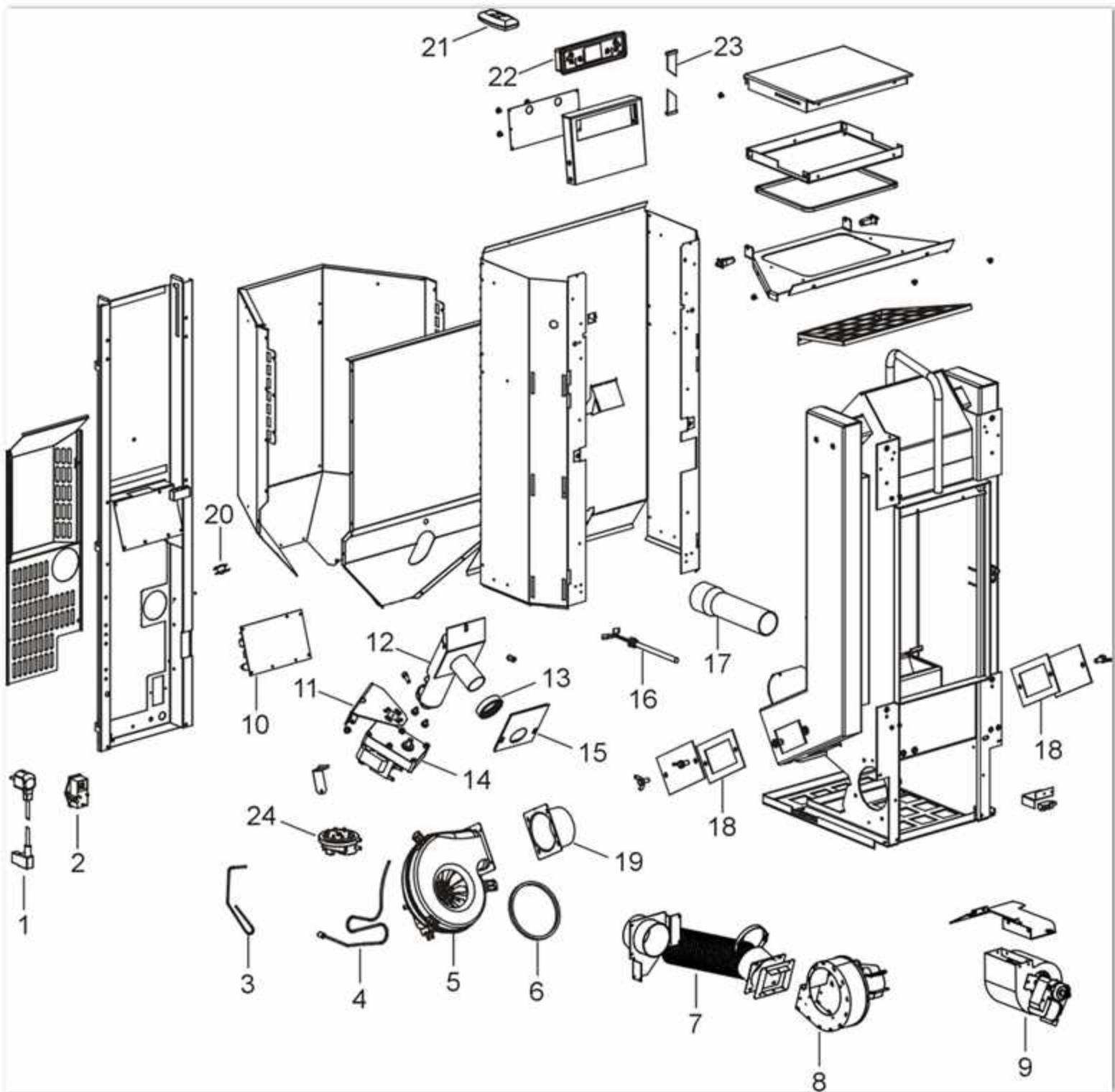

VEGA/VEGA GH/VEGA SL AT/VEGA AIRTIGHT

Componenti interni meccanici ed elettronici dal SN 2103306010019 / Electrical and mechanic internal parts starting from SN 2103306010019 / Interne elektrische und mechanische Baulteile ab SN 2103306010019 / Composants internes électriques et mécaniques à partir du NS 2103306010019 / Componentes internos electrónicos y mecánicos a partir de NS 2103306010019

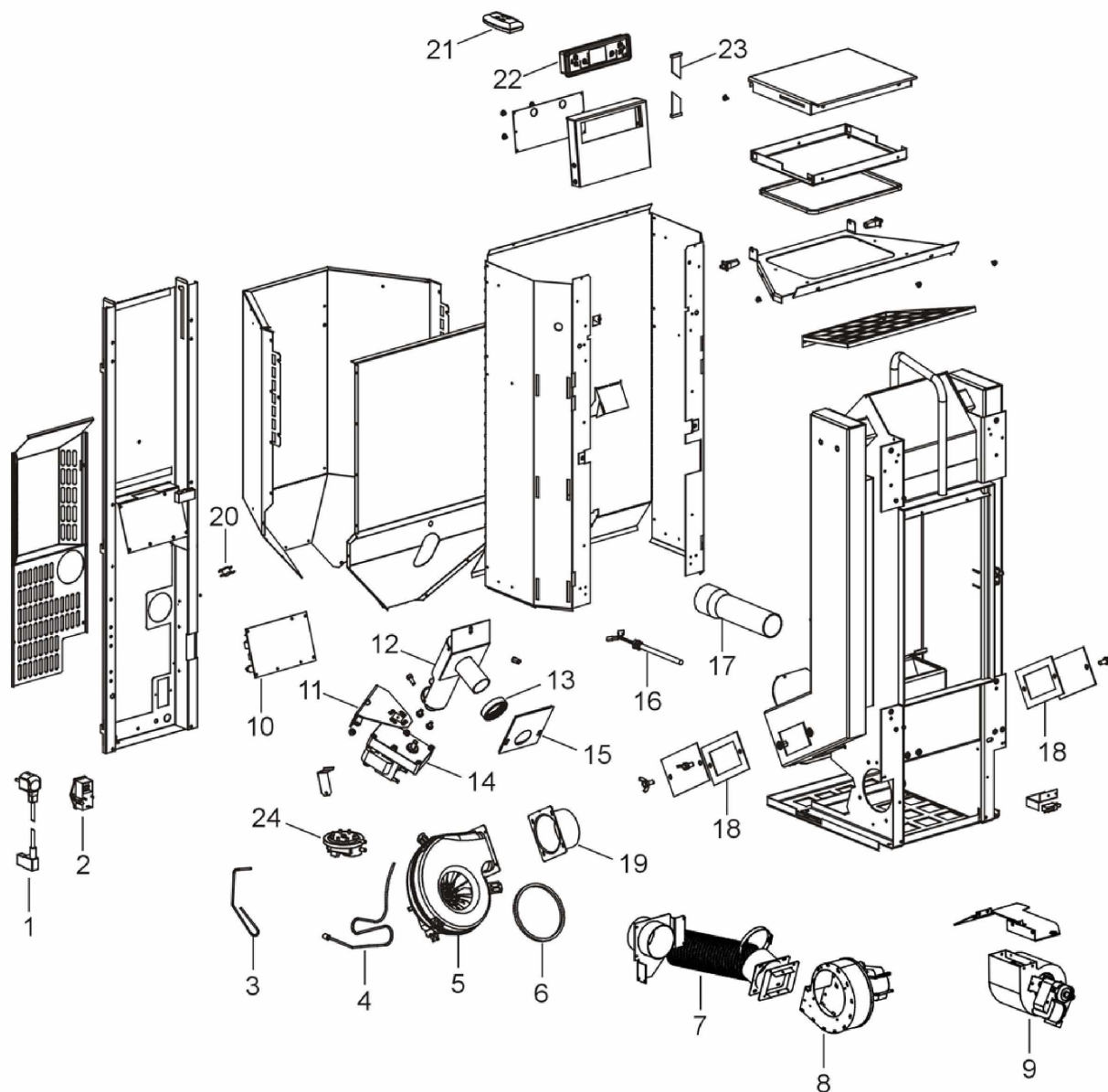

N°	Codice/Code	Descrizioni / Description / Beschreibung / Description / Descripción	Prezzo (€)
1	4D14513041	Cavo alimentazione / Power source cable / Zündungskabel / Câble alimentation / Cable alimentación	25.00
2	4160193	Pulsante accensione / On/Off button / Zündungstaste / Touche d'allumage / Botón encendido	28.00
3	4D145150090	Sonda fumi / Smoke sensor / Rauchsonde / Sonde fumées / Sonda humos	28.00
4	4D145150110	Sonda ambiente / Room temperature sensor / Raumtemperaturfühler / Sonde température ambiance / Sonda ambiente	23.00
5	4D145140150	Ventilatore fumi stagno / Air-tight smoke exhausted fan / Luftdichtes Rauchgasgebläse / Ventilateur fumées étanche / Ventilador humos hermético	121.00
5	41801600800	Guarnizione ventilatore fumi / Smoke exhaust fan gasket / Dichtung Rauchabsauggebläse / Joint Ventilateur aspiration fumées / Junta ventilador aspiración humos	22.00
6	4D18013024	Guarnizione / Gasket / Dichtung / Joint / Junta	26.00
7	4D160140060	Tubo flessibile alluminio D.80 L.200 mm / Flexible aluminium hose D.80 L.200 mm / Aluflexrohr D.80 L.200 mm / Tuyau flexible en aluminium D.80 L.200 mm / Tubo flexible en aluminio D.80 L.200 mm	23.00

8	4D145201070	Ventilatore aria / Air fan / Luftgebläse / Ventilateur air / Ventilador aire	91.00
9	4D14513054	Ventilatore aria / Air fan / Luftgebläse / Ventilateur air / Ventilador aire	114.00
9	4D145198020	Ventilatore aria / Air fan / Luftgebläse / Ventilateur air / Ventilador aire	78.00
10	4D1452002400A	Scheda W002_D01 / Motherboard W002_D01 / Hauptplatine W002_D01 / Carte mère W002_D01 / Tarjeta madre W002_D01	204.00
11	4D2401302613	Supporto coclea / Feed screw support / Schnecke Halterung / Support de la vis-sans-fin / Soporte cóclea	37.00
12	4D140160030	Coclea di caricamento pellet / Pellet feed screw / Pelletsförderschnecke / Vis sans fin pour chargement du pellet / Cóclea de carga pellet	163.00
12	4D180177070	Coclea di caricamento pellet / Pellet feed screw / Pelletsförderschnecke / Vis sans fin pour chargement du pellet / Cóclea de carga pellet	141.00
12	4D180177010	Boccola / Bushing / Buchse / Douille / Abrazadera	23.00
13	4D18013003	Guarnizione D.50 mm / Gasket D.50 mm / Dichtung D.50 mm / Joint D.50 mm / Junta D.50 mm	26.00
14	4D145159010	Motoriduttore 3,3 rpm / Reduction motor 3,3 rpm / Getriebemotor 3,3 rpm / Motorréducteur 3,3 rpm / Motorreductor 3,3 rpm	120.00
14	4D145181020	Motoriduttore 2 rpm / Reduction motor 2 rpm / Getriebemotor 2 rpm / Motorréducteur 2 rpm / Motorreductor 2 rpm	107.00
15	4D18013004	Guarnizione 100X108 mm / Gasket 100X108 mm / Dichtung 100x108 mm / Joint 100X108 mm / Junta 100X108 mm	28.00
16	4D14513002	Candeletta / Sparkplug / Zündkerze Pelletzündung / Bougie / Bujía encendido pellet	50.00
16	4D145181040	Candeletta / Sparkplug / Zündkerze / Bougie / Bujía	51.00
17	4D160140040	Tubo ingresso aria 60x2x210 mm / Air inlet pipe 60x2x210 mm / Lufteingangrohr 60x2x210 mm / Tuyau entrée air 60x2x210 mm / Tubo entrada aire D.80 L.200 mm	30.00
18	4D18013001	Guarnizione 130x80 mm / Gasket 130x80 mm / Dichtung 130x80 mm / Joint 130x80 mm / Junta 130x80 mm	26.00
18	4D18013001	Guarnizione 130x80 mm / Gasket 130x80 mm / Dichtung 130x80 mm / Joint 130x80 mm / Junta 130x80 mm	26.00
19	4D14513040	Raccordo D.80 mm / Connector D.80 mm / Anschlußrohr D.80 mm / Raccord D.80 mm / Racor D.80 mm	22.00
20	4D14513006	Termostato 60°C / Thermostat 60°C / Thermostat 60°C / Thermostat 60°C / Termostato 60°C	48.00
21	5019012	Telecomando / Remote control / Fernbedienung / Télécommande / Mando a distancia	55.00
22	4D14513032	Pannello comandi / Control panel / Bedienblende / Tableau de commande / Panel de mandos	114.00
22	4D1451303300	Pannello comandi grafico / Graphic control panel / Graphische Bedienblende / Tableau de commande / Panel de mandos gráfico	138.00
23	4D14513007	Cavo flat scheda-pannello / Flat cable motherboard-control panel / Flat Kabel Hauptplatine-Bedienblende / Câble flat carte mère-panneau commande / Cable flat tarjeta madre-panel de mandos	31.00
24	4160482	Pressostato 0,4 mbar / Pressure gauge 0,4 mbar / Druckwächter 0,4 mbar / Pressostat 0,4 mbar / Presostato 0,4 mbar	38.00
25	4D241140013	Carter posteriore / Back carter / Hinteres Blech / Protection arrière / Carter trasero	71.00