

**Pièces de rechange  
 Pezzi di ricambio  
 Piezas de recambio  
 Spare parts list  
 NC4, NC6 R101, NC4, NC6, NC9 H101**

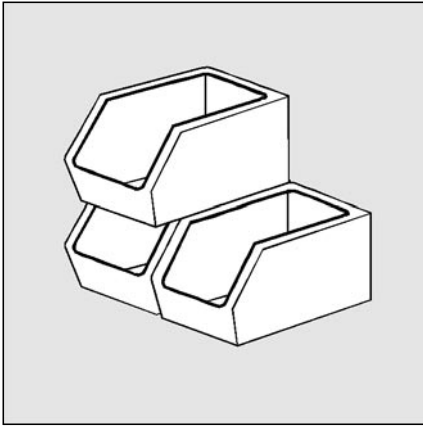

NC 4 R101 0,60 G	13 009 332
NC 4 H101 0,60 G	13 009 330
NC 4 H101 0,75 G	13 009 037
NC 6 R101 1,00 G	13 012 303
NC 6 H101 1,00 G	13 009 331
NC 9 H101 1,25 G	13 009 305

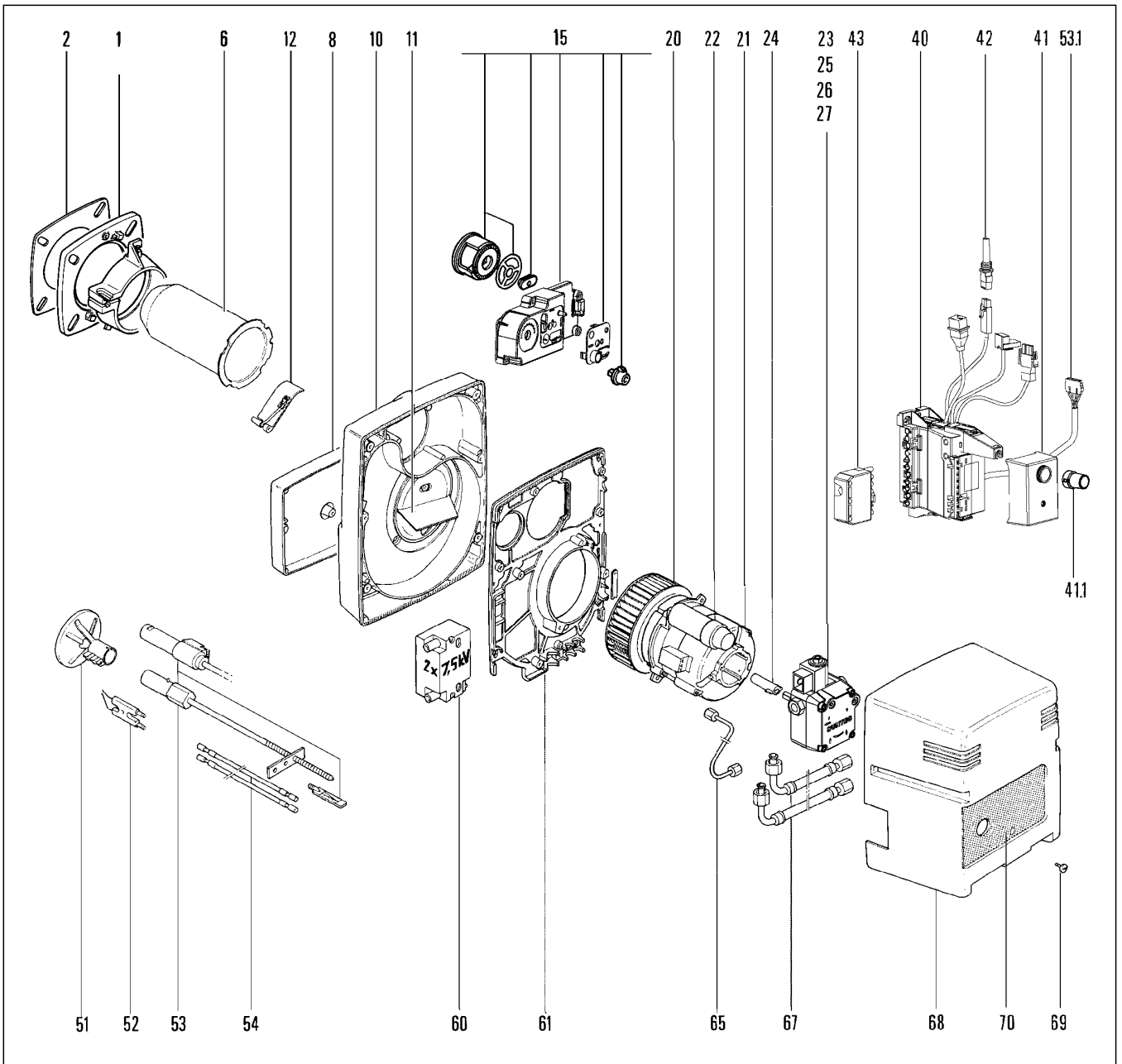



Pos.	Désignation	Denominazione	Designación	Description	Art. Nr.	
01	Accessoires chaudière NC4/6 Ø80 NC9 Ø90	Accessori caldaia	Accesorios caldera	Boiler accessories	13 015 505 13 015 506	
02	Joint façade NC4/6 Ø80 NC9 Ø90	Guarnizione	Junta	Flange	13 016 209 13 016 210	
06	Embout NC4/6 Ø63/80 L: 177 NC9 Ø75/90 L: 192	Imbuto	Canón	Blast tube	13 015 900 13 015 874	
08	Boîte à air NC4/6 NC9	Scatola d'aria	Caja de aire	Air damper cover		
10	Carter	Carter	Carcasa	Burner		
11	Recyclage d' air	Riciclaggio aria	Diafragma de aire	Recycling air		
12	Clapet d'air NC4/6	Serranda aria	Valv.de aire de depression	Air flap	13 016 791	
15	Kit tableau de bord	Kit registro d'aria	Set compuerta de aire	Set control panel	13 016 248	
20	Turbine NC4/6 Ø133x42 NC9 Ø133x62	Turbina	Turbina	Air fan	13 016 686 13 016 687	
21	Moteur	Motore	Motor	Motor	13 016 379	
22	Condensateur	Condensatore	Condensador	Condensator	13 015 720	
23	Kit pompe AS 47 D 1596	Pompa AS 47 D 1596	Bomba	Pump AS 47 D 1596	13 016 262	
24	Accouplement pompe	Accoppiamento pompa	Acoplamiento bomba	Coupling pump	13 015 525	
25	Bobine	Bobina	Bobina	Magnet coil	13 015 572	
26	Kit filtre	Filtro	Filtro	Filter inlet	13 016 253	
27	Kit électrovanne	Kit elettrovalvola	Set electrovalvula	Set electrovalve	13 016 768	
40	Cassette raccordement pré-câblée	Cassetta di collegamento elettr.	Casete de conexión elect.	Elec. connection box alone	13 015 685	
41	Coffret fuel 1 all.	Programmatore	Cajade de control	Control unit	13 015 697	
41.1	Bouton rallonge				13 016 853	
42	Cellule MZ 770 S	Cellula MZ 770 S	Célula MZ 770 S	Photocell MZ 770 S	13 015 692	
43	Prise Wieland mâle 7P/ chaud.	Connettore maschio 7P.	Toma 7P.	Wieland plug 7P.	13 016 494	
51	Défecteur NC4 Ø63/16-4FD NC6 Ø63/20-6FD NC9 Ø75/20-6FG	Deflettore	Deflector	Turbulator	13 015 743 13 015 744 13 015 799	
52	Electrode allu. (marron)	Elettrodo accensione	Electrodos d'encendido	Ignition electrode (brown)	13 015 848	
53	Ligne gicleur + réglette NC4/6 NC4/6 R NC9	Linea porta ugello + etichetta	Línea pulverizador + placa	Nozzle assembly + ruler	13 016 277 13 016 309 13 016 278	
53.1	Câble réchauffeur	Cavo riscaldatore			13 015 631	
54	Câble allu. L225	Cavo accensione	Cables de encendido	Ignition lead	13 015 611	
60	Transformateur allu. 2x7,5kV	Trasformatore di accensione	Transformador de encendido	Ignition transfo.	13 016 671	
61	Platine	Piastra	Platina	Main board		
65	Tube Po./ligne gicleur	Tubetto pompa/ l.p.u.	Tubo bomba/ llinea	Oil feed tube		



Pos.	Désignation	Denominazione	Designación	Description	Art. Nr.	
67	Flexible 1,0 m	Tubi flessibili	Latiguillos flexibles	Oil hose	13 015 503	
68	Capot équipé	Coperchio equip.	Tapa	Cover cpl.	13 015 666	
69	Vis	Vite	Tornillo	Screw	13 016 776	
70	Plaque frontale	Marchio frontale		Front cover		