

**Ersatzteilliste**    **Gas-Gebläsebrenner**  
**Spare part list**    **Gas burner**  
**Vue éclatée**    **Brûleur gaz**  
**C 500 GD 507**

---

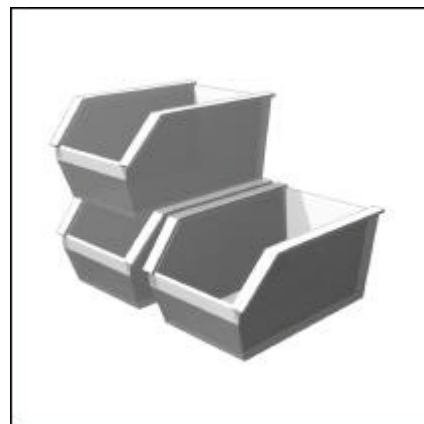

	<b>Pos.</b>	<b>Bezeichnung</b>		<b>Artikel-Nr.</b>
	<b>Pos.</b>	<b>Description</b>		<b>Article-No.</b>
	<b>Pos.</b>	<b>Description</b>		<b>Nr. articles</b>
<b>Baugruppe</b>	1	Grundausstattung	C 400 - 500 G	
<b>Ass.group:</b>		Basis equipment		
<b>Ensemble:</b>		Equipement de base		
	1.1	Abdeckprofil Linkage ass. cover Profil en plastique	300mm	
	1.2	Schauglas Sight glass Regard	55x21	
	1.3	Schauglasdeckel Sight glass cover Couvercle pour regard	D55	
	1.4	Dichtung (Schwenkflansch) Swivel flange Gasket Joint	D 420x420x8 BO 330	
<b>Baugruppe</b>	2	Ausführungsvariante	C 500 GD 507	
<b>Ass.group:</b>		Version		
<b>Ensemble:</b>		Version		
	2.1	Stellantrieb Actuator Servo-moteur	SQM 11 - 16502	13019247
<b>Baugruppe</b>	2.20	Zündtrafo		
<b>Ass.group:</b>		Ignition transformer		
<b>Ensemble:</b>		Transformateur d'allumage		
	2.20.1	Zündtrafo Ignition transformer Transformateur d'allumage	ZE 30/7	13019248
<b>Baugruppe</b>	4	Motor BG	400/690V	
<b>Ass.group:</b>		Motor		
<b>Ensemble:</b>		Moteur		
	4.1	Motor Motor Moteur	7,5kW 400/690V 50Hz 3000/min	13019268
<b>Baugruppe</b>	5	Ventilatorrad BG	C 500 50 Hz	
<b>Ass.group:</b>		Air fan ass.		
<b>Ensemble:</b>		Turbine		
	5.1	Ventilatorrad Air fan Turbine		13019269
<b>Baugruppe</b>	6	Luftansaugkasten kpl.	C 260 - C 620	
<b>Ass.group:</b>		Air intake housing cpl.		
<b>Ensemble:</b>		Boîte à air cpl.		

	<b>Pos.</b>	<b>Bezeichnung</b>		<b>Artikel-Nr.</b>
	<b>Pos.</b>	<b>Description</b>		<b>Article-No.</b>
	<b>Pos.</b>	<b>Description</b>		<b>Nr. articles</b>
<b>Baugruppe</b>	11	Druckwächter BG	DL 50 A	
<b>Ass.group:</b>		Pressure switch		
<b>Ensemble:</b>		Pressostat différentiel		
	11.1	Luftdruckwächter Air pressure switch Pressostat air	DL 50A 2,5-50 mbar	13019251
<b>Baugruppe</b>	14	Lanzengaskopf	C 500 GD 507	
<b>Ass.group:</b>		Lancee gas head basis ext.		
<b>Ensemble:</b>		Tête gaz multijet		
	14.10	Flammenrohr Grundl. Flame tube Embout	D325x612	13019264
	14.20	Stauscheibe Brake plate Deflecteur	D220 Tk 210	13019270
	14.30	Schieberohr Adjusting tube Tube réglable	D35/2,2x420	
	14.31	Schieberohr Adjusting tube Tube réglable	D35/2,2x420	
	14.35	Distanzrohr Distance tube Entretoise	D30x2 45grd 45/95	
	14.36	Distanzrohr Distance tube Entretoise	D30x2 45grd 30/95	
	14.40	Gasdüse Gas nozzle Injecteur gaz	D 35x2,2 BO18	
	14.60	Zündelektrode Ignition electrode Électrode d'allumage	D14x125/150mm	13019263
	14.61	Zündkabel Ignition lead Câble d'allumage	1500 mm	13019255
	14.62	Ionisationselektrode Ionisation electrode Sonde ionisation	D 14x125/125	13019256
	14.63	Kabel f. Ionisationselektrode Ionisation cable Câble ionisation		13019257
	14.90	Dichtung Gaskopf Gas Lance Gasket Joint	D 130/90x2	

	<b>Pos.</b>	<b>Bezeichnung</b>		<b>Artikel-Nr.</b>
	<b>Pos.</b>	<b>Description</b>		<b>Article-No.</b>
	<b>Pos.</b>	<b>Description</b>		<b>Nr. articles</b>
<b>Baugruppe</b>	14	Lanzengaskopf 100 Verl.	C 500 GD 507	
<b>Ass.group:</b>		Lanee gas head		
<b>Ensemble:</b>		Tête gaz multijet		
	14.10	Flammenrohr 100 Verl. Flame tube Embout	D325x712	13019266
	14.30	Schieberohr Adjusting tube Tube réglable	D35/2,2x520	
	14.31	Schieberohr Adjusting tube Tube réglable	D35/2,2x520	
	14.35	Distanzrohr Distance tube Entretoise	D30x2 45grd 45/95	
	14.36	Distanzrohr Distance tube Entretoise	D30x2 45grd 30/95	
<b>Baugruppe</b>	14	Lanzengaskopf 200 Verl.	C 500 GD 507	
<b>Ass.group:</b>		Lanee gas head		
<b>Ensemble:</b>		Tête gaz multijet		
	14.10	Flammenrohr 200 Verl. Flame tube Embout	D325x812	13019267
	14.30	Schieberohr Adjusting tube Tube réglable	D35/2,2x620	
	14.31	Schieberohr Adjusting tube Tube réglable	D35/2,2x620	
	14.35	Distanzrohr Distance tube Entretoise	D30x2 45grd 45/95	
	14.36	Distanzrohr Distance tube Entretoise	D30x2 45grd 30/95	
<b>Baugruppe</b>	20	Beipack	C 400 / 500	
<b>Ass.group:</b>		Accessory		
<b>Ensemble:</b>		Accessoires		
	20.1	Dichtung (Kesselseitig) Burner to Boiler Gasket Joint	D 420x420x3 BO 348	

	<b>Pos.</b>	<b>Bezeichnung</b>	<b>Artikel-Nr.</b>
	<b>Pos.</b>	<b>Description</b>	<b>Article-No.</b>
	<b>Pos.</b>	<b>Description</b>	<b>Nr. articles</b>
<b>Baugruppe</b>	21	Kabel Gasstrecke AGP	C 260 - C 500
<b>Ass.group:</b>		Cable for gas train	
<b>Ensemble:</b>		Câble	
	21.1	Gerätesteckdose Plug Prise électrique	GDMW 30-11
	21.2	Stecker Plug La fiche	AGA 64
	21.3	Stecker Plug La fiche	VPS 504-02

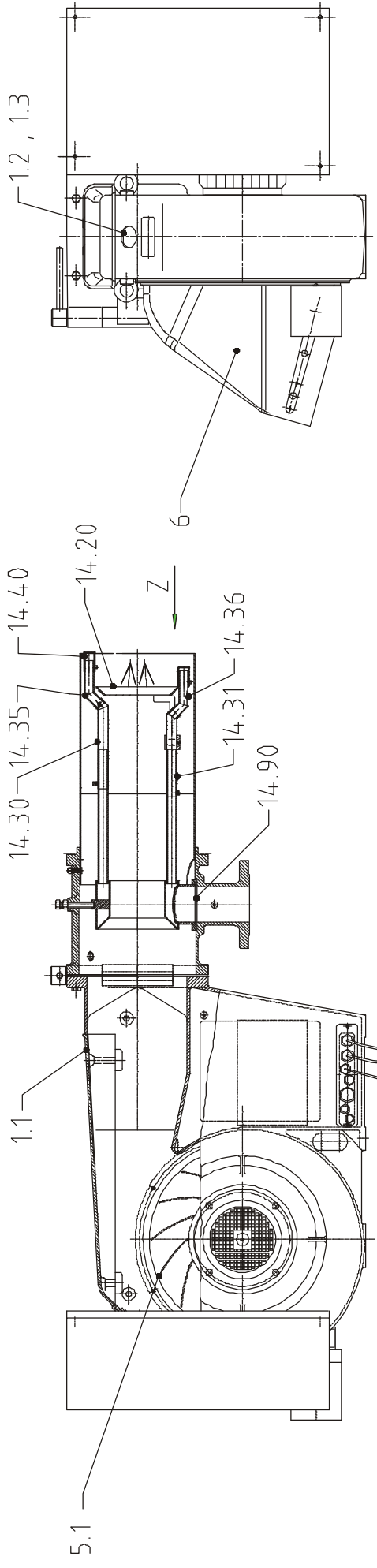

- 21.1 GDMW
- 21.2 AGA64
- 21.3 VPS

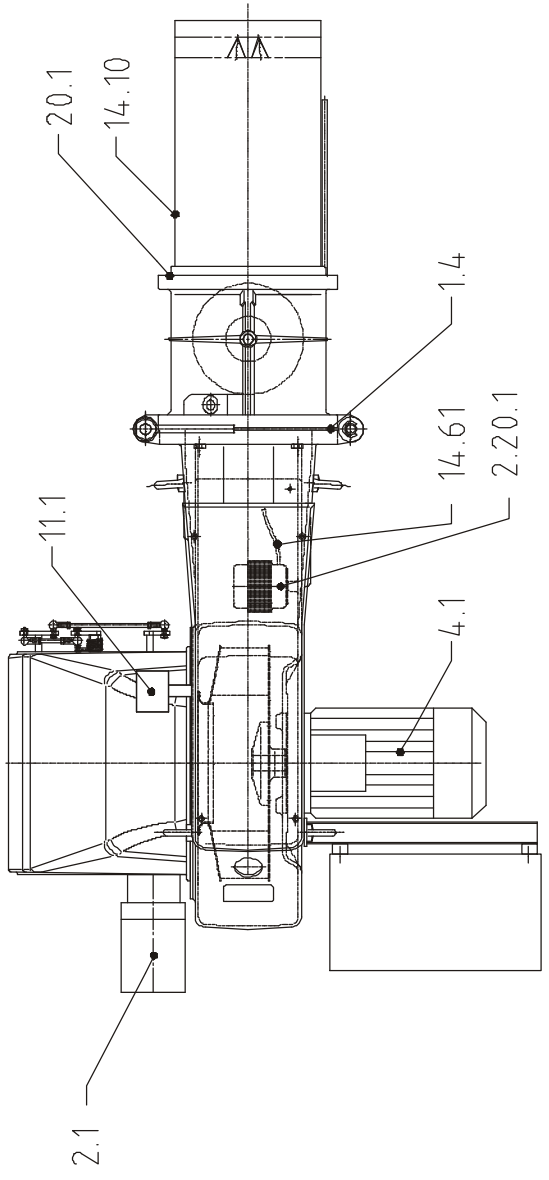

Z (2:1)

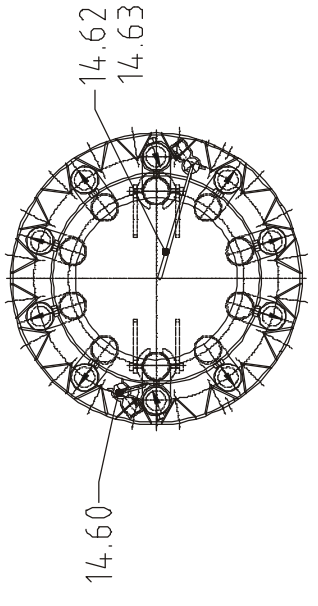

---

**Ausstattung:** Die Gasklappe ist kommissionsbezogen zu bestellen.

**Equipment:** The gas valve as ordered for commission specification.

**Accessoires:** Le registre gaz doit être commandé en fonction de l'installation.

Weitere Teile auf Anfrage.  
Further spare part on request.  
Autres pièces détachées sur demande.

**Revision**

Änderungen im Sinne der technischen Weiterentwicklung vorbehalten.  
Modifications to incorporate latest technical developments are reserved.  
Sous réserve de modifications résultant du perfectionnement technique.

Kundendienst:  
Service:  
Votre service après-vente:

CUENOD  
18,rue des Buchillons  
F-74100 ANNEMASSE Cedex