

VUE ECLATEE

CHAUFFAGE DOMESTIQUE

Modèle

CELTIC & GM RSc

R8202212-05FR - Edition 05 - 23/11/2009

211 531	CELTIC 1.12 RSc "b" CF NAT
211 521	CELTIC 1.12 RSc "b" CF B/P
211 631	GM 1.12 RSc CF NAT
211 621	GM 1.12 RSc CF B/P
241 531	CELTIC TIG 12 RSc "b" CF NAT
241 631	GM TIG 12 RSc CF NAT
241 621	GM TIG 12 RSc CF B/P
241 536	CELTIC TIG 12 RSc "b" VMC NAT
223 031	CELTIC 2.16 RSc CF NAT
223 021	CELTIC 2.16 RSc CF B/P
223 011	CELTIC 2.16 RSc CF GV
223 131	GM 2.16 RSc CF NAT
223 121	GM 2.16 RSc CF B/P
213 031	CELTIC 1.16 RSc CF NAT
200000 213 021	CELTIC 1.16 RSc CF B/P
213 131	GM 1.16 RSc CF NAT
213 121	GM 1.16 RSc CF B/P
243 131	GM TIG 16 RSc CF NAT
243 121	GM TIG 16 RSc CF B/P
243 111	GM TIG 16 RSc CF GV
224 236	CELTIC 2.18 RSc VMC NAT - MG 2.18 VMC RSc
224 226	CELTIC 2.18 RSc VMC B/P - MG 2.18 VMC RSc
224 136	GM 2.18 RSc VMC NAT
224 126	GM 2.18 RSc VMC B/P
225 431	CELTIC 2.20 RSc CF NAT - MG 2.20 RSc
225 421	CELTIC 2.20 RSc CF B/P - MG 2.20 RSc
225 411	CELTIC 2.20 RSc CF GV - MG 2.20 RSc
225 531	GM 2.20 RSc CF NAT
225 521	GM 2.20 RSc CF B/P
225 511	GM 2.20 RSc CF GV
225 436	CELTIC 2.20 RSc VMC NAT
225 426	CELTIC 2.20 RSc VMC B/P
225 536	GM 2.20 RSc VMC NAT
225 526	GM 2.20 RSc VMC B/P
215 431	CELTIC 1.20 RSc CF NAT - MG 1.20 RSc
215 421	CELTIC 1.20 RSc CF B/P - MG 1.20 RSc
245 431	CELTIC TIG 20 RSc CF NAT - MGB 2.20 RSc
245 421	CELTIC TIG 20 RSc CF B/P - MGB 2.20 RSc
245 411	CELTIC TIG 20 RSc CF GV - MGB 2.20 RSc
245 531	GM TIG 20 RSc CF NAT
226 931	CELTIC 2.24 RSc CF NAT - MG 2.24 RSc
226 921	CELTIC 2.24 RSc CF B/P - MG 2.24 RSc
226 911	CELTIC 2.24 RSc CF GV - MG 2.24 RSc
226 831	GM 2.24 RSc CF NAT
226 821	GM 2.24 RSc CF B/P

226 936		CELTIC 2.24 RSc VMC NAT
226 926		CELTIC 2.24 RSc VMC B/P
216 931		CELTIC 1.24 RSc CF NAT
216 921		CELTIC 1.24 RSc CF B/P
246 811		GM TIG 24 RSc CF GV
228 231		CELTIC 2.30 RSc CF NAT
228 221		CELTIC 2.30 RSc CF B/P
218 231		CELTIC 1.30 RSc CF NAT
218 221		CELTIC 1.30 RSc CF B/P
248 231		CELTIC TIG 30 RSc CF NAT
248 221		CELTIC TIG 30 RSc CF B/P

Code	Ind.	Modèle	Date Début	Date Fin
------	------	--------	------------	----------

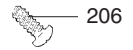
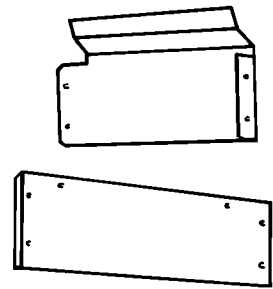
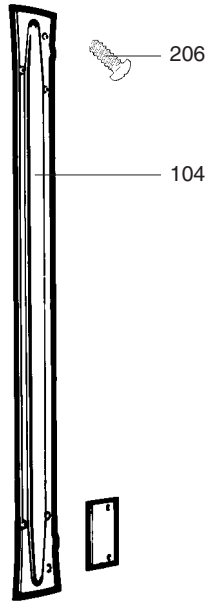
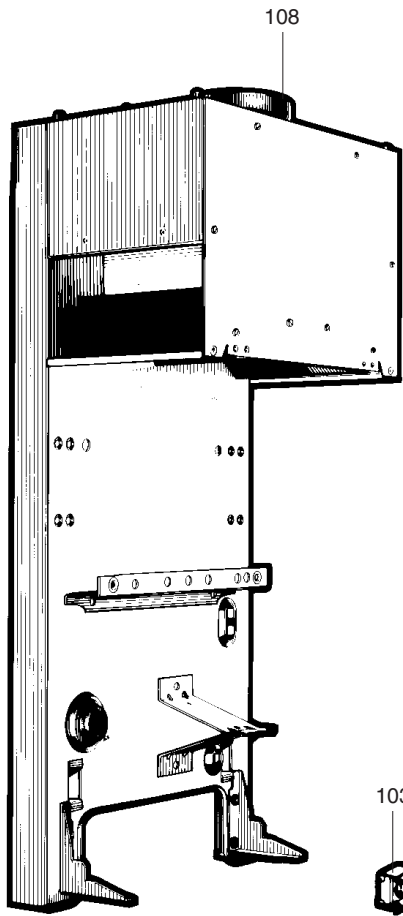

300

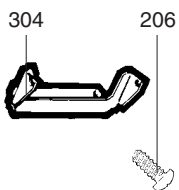
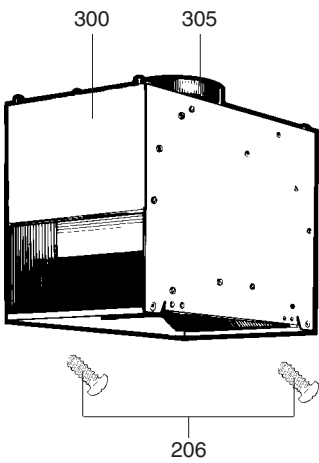

200

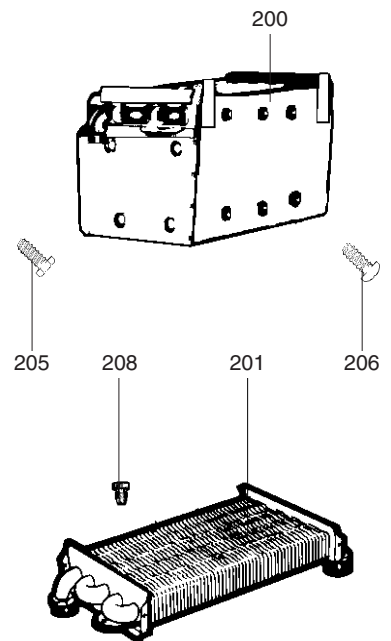
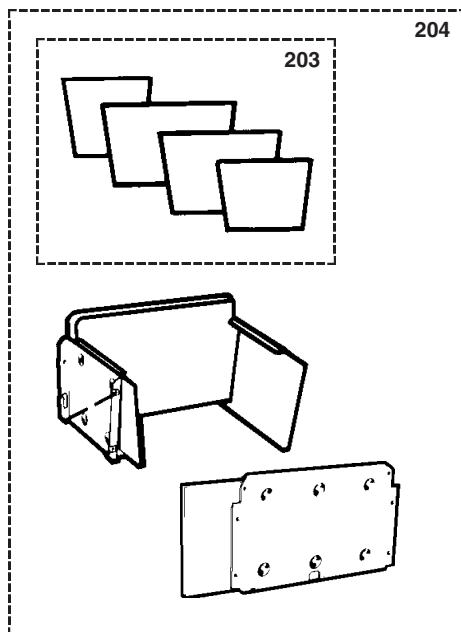

Rep.	Désignation	Référence	Type	12		16		18		20			24			30		Date	
				TIG 12		TIG 16		TIG 18		TIG 20			TIG 24			TIG 30			
				CF	VMC	CF	VMC	CF	VMC	CF	VMC	CF	VMC	CF	VMC	CF	VMC	de	à
0100	CHASSIS																		
0103	ECROU EN CAGE M 6	60004806-03		•	•	•	•	•	•	•	•	•	•	•	•	•	•		
0104	GOUTTIERE	60045939																	
0108	COIFFE ANTIREFOULEUR	60049416																	
0200	CORPS DE CHAUFFE (ENSEMBLE)	60042520		•	•	•	•	•											
	CORPS DE CHAUFFE (ENSEMBLE)	60042522																	
	CORPS DE CHAUFFE (ENSEMBLE)	60042524																	
	CORPS DE CHAUFFE	61015266																	
0201	ECHANGEUR CORPS DE CHAUFFE	60042513-06		•	•	•	•	•											
	ECHANGEUR CORPS DE CHAUFFE	60042517-06																	
	ECHANGEUR CORPS DE CHAUFFE	60078242-06																	
	ECHANGEUR CORPS DE CHAUFFE	61014130																	
0203	GARNITURES CERAPLAQUE (Poch.)	60081001																	
	GARNITURES CERAPLAQUE (Poch.)	60081137																	
	GARNITURES CERAPLAQUE (Poch.)	60081203																	
	GARNITURES CERAPLAQUE (Poch.)	60081491		•	•	•	•	•											
0204	CHAMBRE DE COMBUSTION (Poch.)	60063666																	
	CHAMBRE DE COMBUSTION (Poch.)	60081002																	
	CHAMBRE DE COMBUSTION (Poch.)	60081130																	
0205	VIS A TOLE CBLX D: 6.3-13	61010648		•	•	•	•	•	•	•	•	•	•	•	•	•	•		
0206	VIS A TOLE CBLX D: 4.2-9.5	61010125		•	•	•	•	•	•	•	•	•	•	•	•	•	•		
0208	BOUCHON / ECHANGEUR	61015264																	
0300	ANTIREFOULEUR D:127 (EQT)	60062391																	
	ANTIREFOULEUR	60078170																	
0304	SUPPORT DE BULBE	60045990																	
0305	VIROLE D: 127	60048198																	

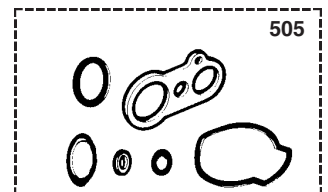
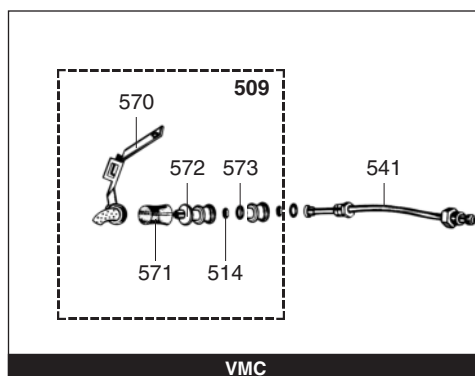
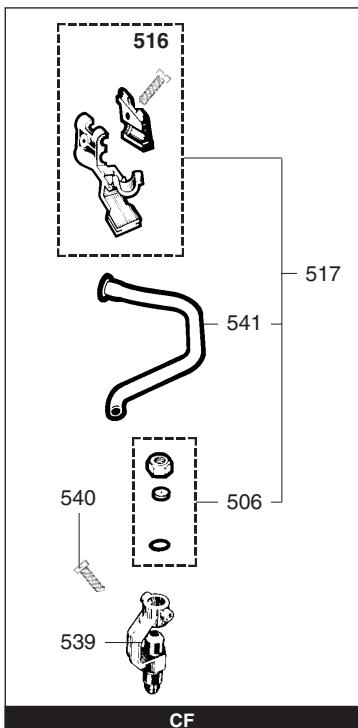
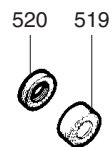
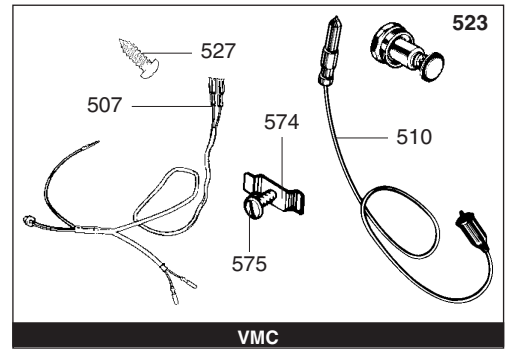
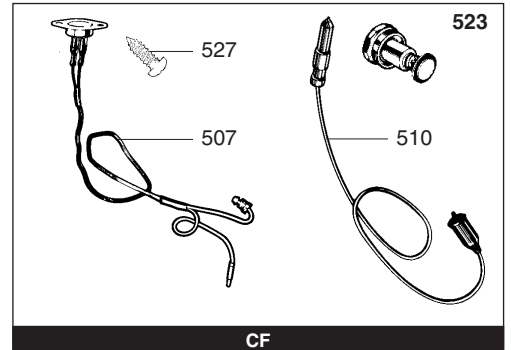
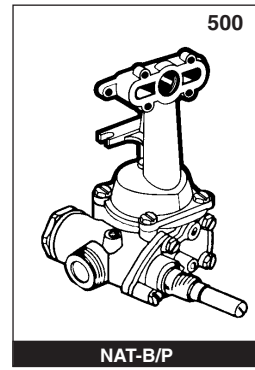
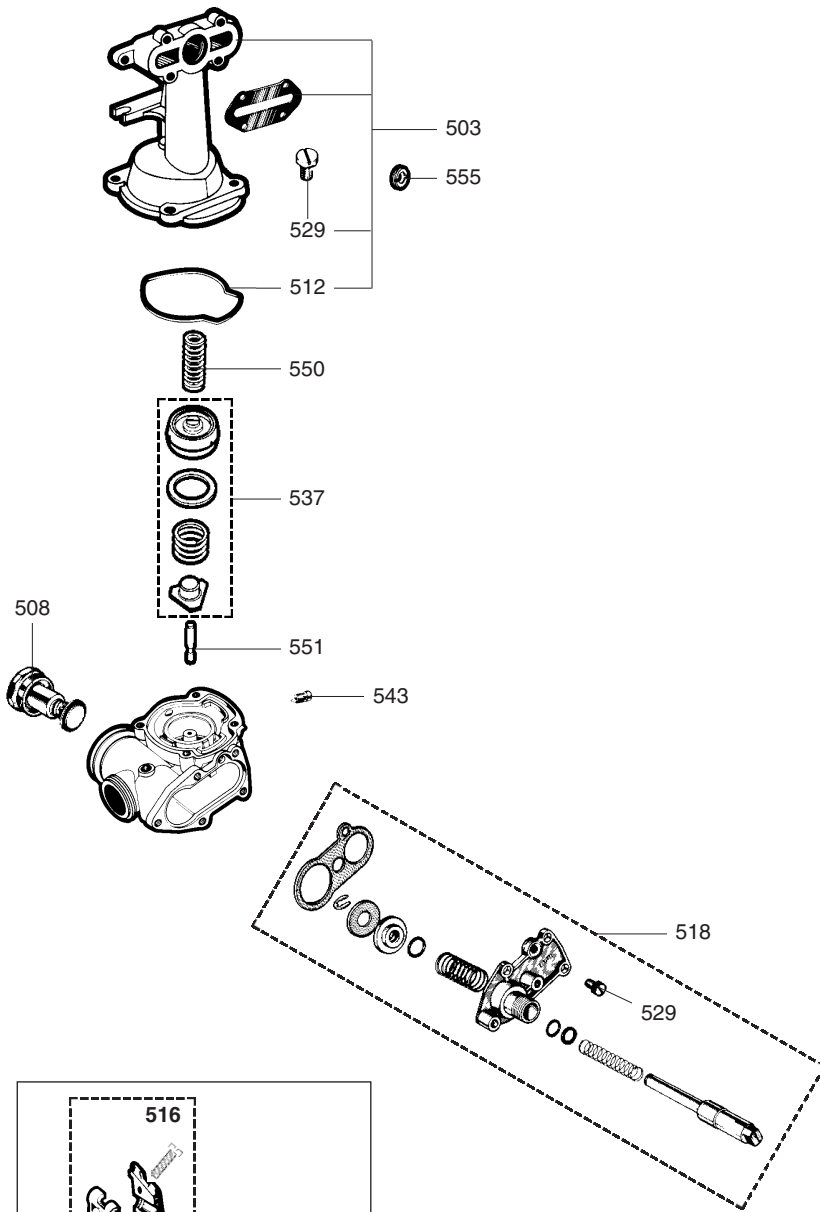

Rep.	Désignation	Référence	Type																									Date	
				12				16				18				20				24				30					
				1.12	TIG 12	2.16	1.16	TIG 16	2.18	2.20	1.20	TIG 20	2.24	1.24	TIG 24	2.30	1.30	TIG 30	de	à									
CF	CF	VMC	CF	CF	CF	VMC	CF	VMC	CF	CF	VMC	CF	CF	VMC	CF	CF	VMC	CF	CF	VMC	CF	CF	VMC	CF	CF	VMC			
0500	ARMATURE GAZ	60046658																											
	ARMATURE GAZ BUT/PROP	60045629	B/P				•	•	•															•	•	•			
	ARMATURE GAZ NAT	60063558	NAT			•																							
0503	EMBASE BRULEUR (POCHETTE)	60081507		•	•	•	•	•	•	•	•	•	•	•	•	•	•	•	•	•	•	•	•	•	•	•	•		
0505	JOINTS ARMATURE GAZ (POCHETTE)	60081410		•	•	•	•	•	•	•	•	•	•	•	•	•	•	•	•	•	•	•	•	•	•	•	•		
0506	INJECTEUR DE VEILLEUSE (Poch.)	60081520	B/P	•	•		•	•	•			•	•	•	•	•	•	•	•	•	•	•	•	•	•	•	•		
	INJECTEUR DE VEILLEUSE (Poch.)	60081406	NAT	•	•		•	•	•			•	•	•	•	•	•	•	•	•	•	•	•	•	•	•	•		
0507	THERMOCOUPLE & SECURITE 110 C	60048839																											
	THERMOCOUPLE & SECURITE 110°C	60070975				•				•	•				•														
	THERMOCOUPLE ALUM. & SECURITE 110°C	60054631	B/P	•	•		•	•	•			•	•	•	•	•	•	•	•	•	•	•	•	•	•	•	•		
	THERMOCOUPLE & SECURITE 110°C	60100342-30	NAT	•	•		•	•	•			•	•	•	•	•	•	•	•	•	•	•	•	•	•	•	•		
0508	BOUCHON MAGNETIQUE	60024800		•	•	•	•	•	•	•	•	•	•	•	•	•	•	•	•	•	•	•	•	•	•	•	•		
0509	VEILLEUSE NAT (Pochette)	60081508	NAT			•				•	•				•														
0510	ELECTRODE ALLUMAGE	60060466		•	•		•	•	•			•	•	•	•	•	•	•	•	•	•	•	•	•	•	•	•		
	ELECTRODE ALLUMAGE	60064743				•				•	•				•														
0512	JOINT D'EMBASE	60024653		•	•	•	•	•	•	•	•	•	•	•	•	•	•	•	•	•	•	•	•	•	•	•	•		
0514	INJECTEUR DE VEILLEUSE D: 0.2	60026645	B/P							•	•				•														
	INJECTEUR DE VEILLEUSE D: 0.3	60026646	NAT			•				•	•				•														
0516	SUPPORT THERMOCOUPLE	60044446		•	•		•	•	•			•	•	•	•	•	•	•	•	•	•	•	•	•	•	•	•		
0517	VEILLEUSE ENS	60100343-30					•	•	•			•	•	•	•	•	•	•	•	•	•	•	•	•	•	•	•		
0518	BLOC POUSSOIR (Pochette)	60081198		•	•	•	•	•	•	•	•	•	•	•	•	•	•	•	•	•	•	•	•	•	•	•	•		
0519	ECROU MOLETE M 16-1	60027409		•	•	•	•	•	•	•	•	•	•	•	•	•	•	•	•	•	•	•	•	•	•	•	•		
0520	CONTRE ECROU M 16-100	60014364		•	•	•	•	•	•	•	•	•	•	•	•	•	•	•	•	•	•	•	•	•	•	•	•		
0523	SECURITE GAZ (POCHETTE)	60081209																											
	SECURITE GAZ (POCHETTE)	60081509		•	•		•	•	•			•	•	•	•	•	•	•	•	•	•	•	•	•	•	•	•		
	SECURITE GAZ (POCHETTE)	60081510				•				•	•				•														
0527	VIS A TOLE CBLZ D: 3.5-6.5	60031521-03		•	•	•	•	•	•	•	•	•	•	•	•	•	•	•	•	•	•	•	•	•	•	•	•		
0529	VIS HS M 6-12	60005799-13		•	•	•	•	•	•	•	•	•	•	•	•	•	•	•	•	•	•	•	•	•	•	•	•		
0537	CLAPET GAZ BUT/PROP A CLIQUET	60045632	B/P				•	•	•																				
	CLAPET GAZ NAT A CLIQUET	60045631	NAT	•	•		•	•	•																				
	CLAPET GAZ NAT A CLIQUET	60047062	NAT																										
	CLAPET GAZ NAT A CLIQUET	60064476	NAT			•																							
0539	PORTE INJECTEUR	60034220		•	•		•	•	•			•	•	•	•	•	•	•	•	•	•	•	•	•	•	•	•		
0540	VIS CS M 3-8	60010764-03		•	•		•	•	•			•	•	•	•	•	•	•	•	•	•	•	•	•	•	•	•		
0541	TUBE VEILLEUSE ENS	60020185				•				•	•				•														
	TUBE VEILLEUSE	60045270		•	•		•	•	•			•	•	•	•	•	•	•	•	•	•	•	•	•	•	•	•		
	TUBE VEILLEUSE	60053937																											
0543	VIS CB M 6-12	60032390-08		•	•	•	•	•	•	•	•	•	•	•	•	•	•	•	•	•	•	•	•	•	•	•	•		
0550	RESSORT 14 x 1.5 L: 33	60026764		•	•	•	•	•	•	•	•	•	•	•	•	•	•	•	•	•	•	•	•	•	•	•	•		
0551	AXE GAZ	60014795		•	•	•	•	•	•	•	•	•	•	•	•	•	•	•	•	•	•	•	•	•	•	•	•		
0555	DIAPHRAGME GAZ D: 4.8	60028417-02	B/P									•	•	•	•	•	•	•	•	•	•	•	•	•	•	•	•		
	DIAPHRAGME GAZ D: 4.2	60028417-05	B/P																										
	DIAPHRAGME GAZ D: 3.4	60028417-17	B/P				•	•	•																				
	DIAPHRAGME GAZ D: 3.85	60028417-35	B/P							•																			
	DIAPHRAGME GAZ D: 5.3	60028417-04	NAT																										
	DIAPHRAGME GAZ D: 4.2	60028417-05	NAT				•	•	•																				
	DIAPHRAGME GAZ D: 5	60028417-10	NAT									•	•	•	•	•	•	•	•	•	•	•	•	•	•	•	•		
	DIAPHRAGME GAZ D: 3.6	60028417-40	NAT-NOTA1	•	•	•																							
	DIAPHRAGME GAZ D: 3.6	60028417	NAT-NOTA2	•	•																								
0570	COIFFE VEILLEUSE	60022391-03				•						•	•																
0571	FILTRE A AIR	60022753-10				•						•	•																
0572	CORPS VEILLEUSE	60024305-20	B/P									•	•																
0573	JOINT DE FORME (/Injecteur)	60026281										•	•																
0574	CROCHET	60017337				•						•	•																
0575	VIS M 4-12	60042585-02				•						•	•																

NOTA 1 : CELTIC
NOTA 2 : GM

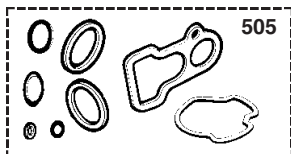
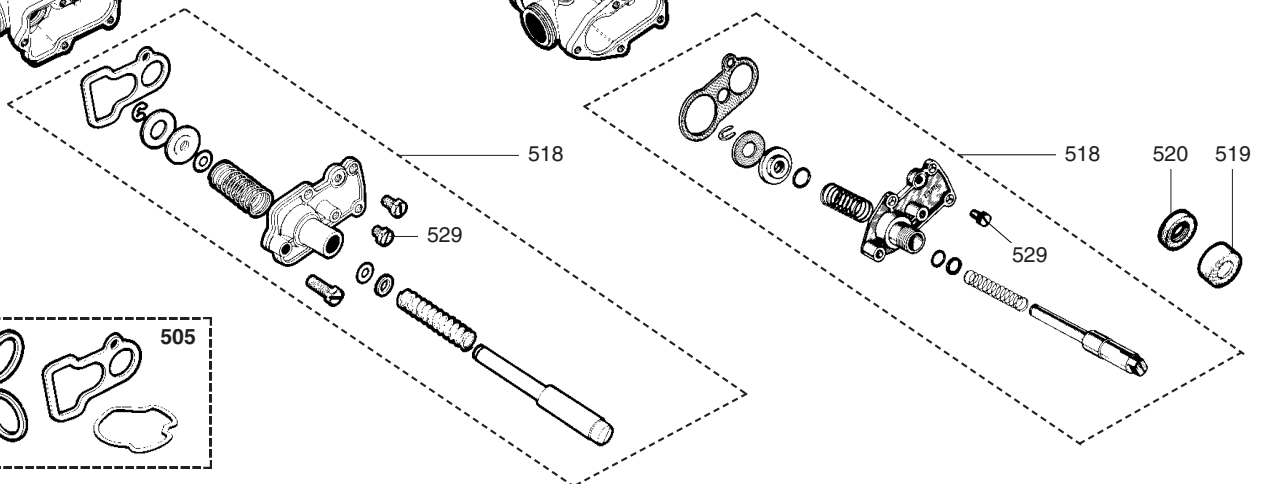
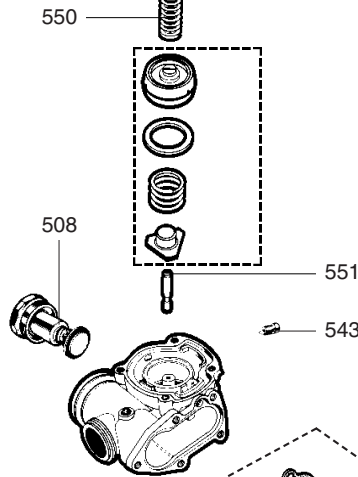
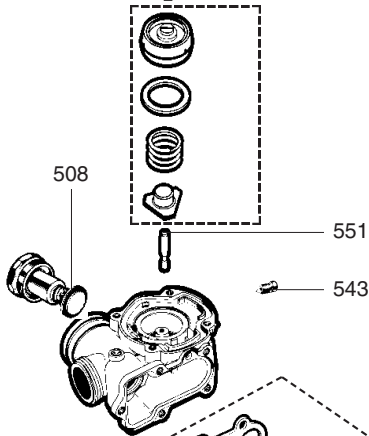
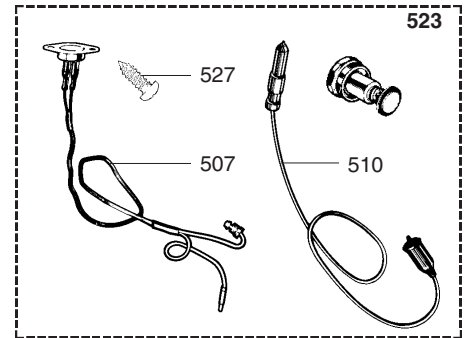
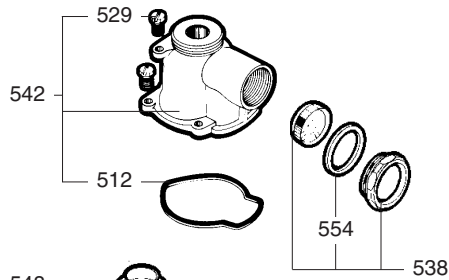
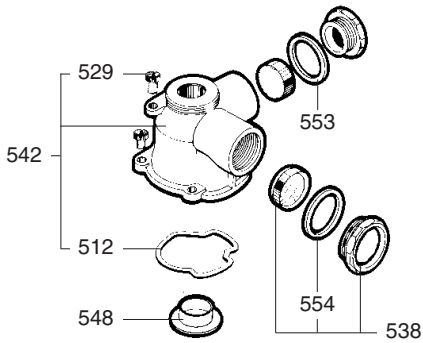
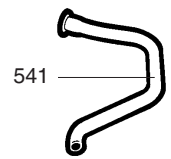
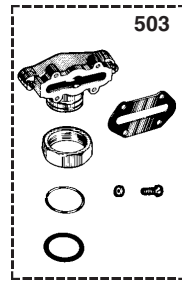
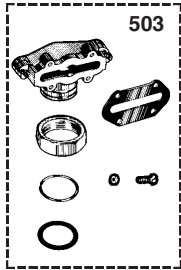
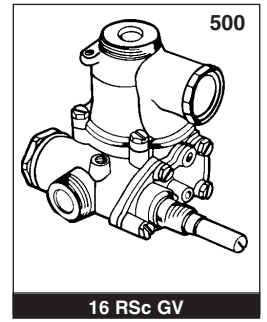
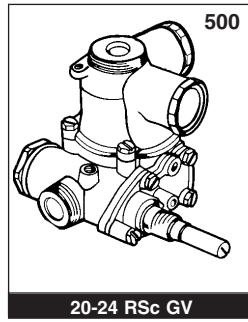

Rep.	Désignation	Référence	Type	12		16		18		20		24		30		Date	
				TIG 12		TIG 16		TIG 18		TIG 20		TIG 24		TIG 30		de	à
				CF	VMC	CF	VMC	CF	VMC	CF	VMC	CF	VMC	CF	VMC		
0500	ARMATURE GAZ																
0503	EMBASE BRULEUR (POCHETTE)	60081408	GV			•	•	•	•	•	•	•					
0505	JOINTS ARMATURE GAZ (POCHETTE)	60081410	GV			•	•										
	JOINTS ARMATURE GAZ (POCHETTE)	60081534	GV					•	•	•	•	•					
0506	INJECTEUR DE VEILLEUSE (Poch.)	60081529	GV			•	•	•	•	•	•	•					
0507	THERMOCOUPLE & SECURITE 110°C	60100342-30	GV			•	•	•	•	•	•	•					
0508	BOUCHON MAGNETIQUE	60024800	GV			•	•										
0510	ELECTRODE ALLUMAGE	60060466				•	•	•	•			•					
0512	JOINT D'EMBASE	60024653	GV			•	•										
	JOINT DE FORME (/Embase)	60024904	GV					•	•	•	•	•					
0516	SUPPORT THERMOCOUPLE	60044446				•	•	•	•	•	•	•					
0518	BLOC POUSSOIR (Pochette)	60081198	GV			•	•										
0519	ECROU MOLETE M 16-1	60027409				•	•	•	•	•	•	•					
0520	CONTRE ECROU M 16-100	60014364				•	•	•	•	•	•	•					
0523	SECURITE GAZ (POCHETTE)	60081509	GV			•	•										
0527	VIS A TOLE CBLZ D: 3.5-6.5	60031521-03				•	•	•	•	•	•	•					
0529	VIS HS M 6-12	60005799-13				•	•	•	•	•	•	•					
0538	BY-PASS (Pochette)	60081197	GV			•	•	•	•	•	•	•					
0539	PORTE INJECTEUR	60034220				•	•	•	•	•	•	•					
0540	VIS CS M 3-8	60010764-03				•	•	•	•	•	•	•					
0541	TUBE VEILLEUSE	60045270				•	•	•	•	•	•	•					
0542	CORPS REGULATEUR (Pochette)	60081195	GV			•	•										
0543	VIS CB M 6-12	60032390-08				•	•	•	•	•	•	•					
0548	FLOTTEUR	60025461	GV					•	•	•	•	•					
	FLOTTEUR	60025463	GV			•	•										
0549	APPUI RESSORT	60025293	GV			•	•										
	APPUI RESSORT	60025367	GV					•	•	•	•	•					
0550	RESSORT 14 x 1.5 L: 33	60026764				•	•	•	•	•	•	•					
0551	AXE GAZ	60014795				•	•	•	•	•	•	•					
0553	JOINT PLAT D: 34-28.5-1.5	60061857-18	GV					•	•	•	•	•					
0554	JOINT PLAT D: 34.5-28.2-2	60061857-09	GV			•	•	•	•	•	•	•					

600

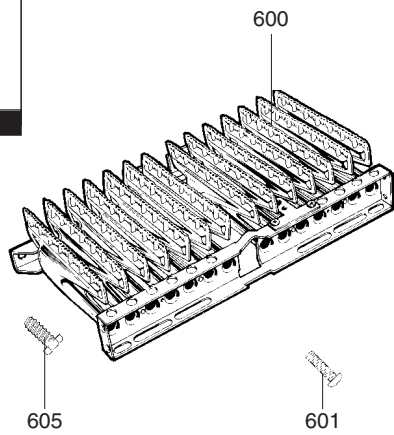
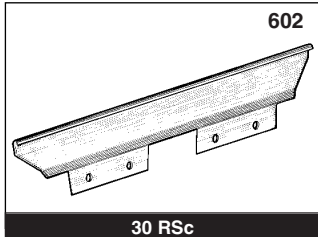
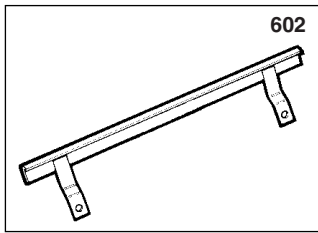

1000

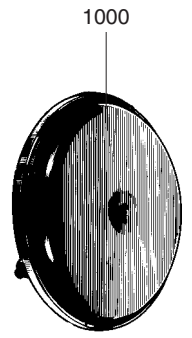
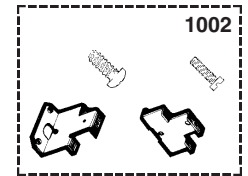
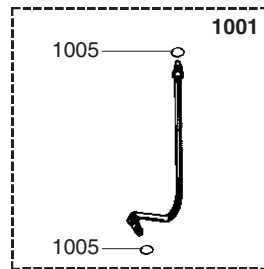
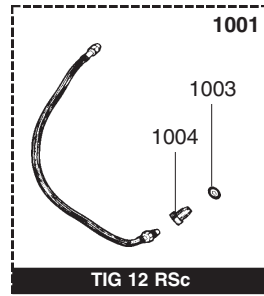

700

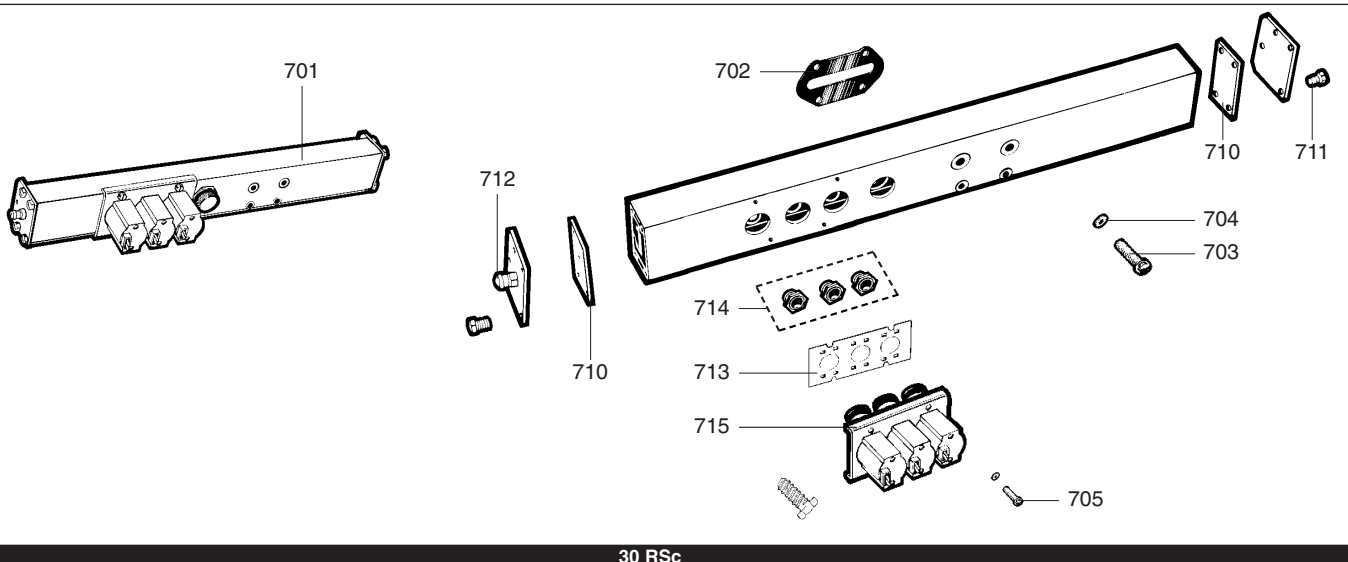
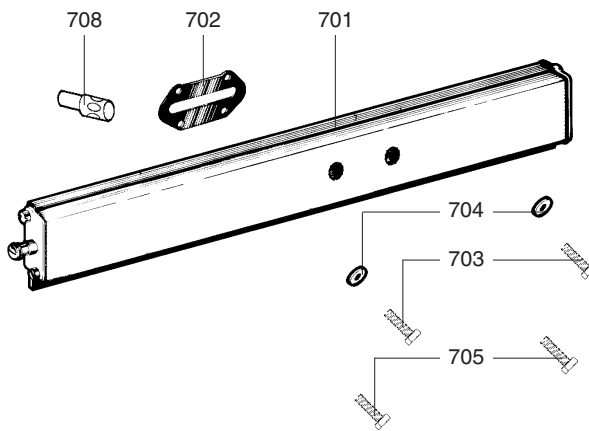

30 RSc

Rep.	Désignation	Référence	Type	12		16		18		20		24		30		Date	
				1-12		1-16		1-18		1-20		1-24		1-30		de	à
				CF	VMC	CF	VMC	CF	VMC	CF	VMC	CF	VMC	CF	VMC		
0600	BLOC DE BECS	60023009-02															
	BLOC DE BECS	60024400-03															
	BLOC DE BECS	60055596		•	•	•	•	•									
0601	VIS M 5-8	60015691-03		•	•	•	•	•	•	•	•	•	•				
0602	GOUTTIERE D'ONDE	60032551								•	•	•	•				
	GOUTTIERE D'ONDE	60032552					•	•	•	•							
	GOUTTIERE D'ONDE	60039809												•	•	•	
	GOUTTIERE D'ONDE	60044524															
0605	VIS A TOLE CBLXS D: 6.3-13	61010648		•	•	•	•	•	•	•	•	•	•	•	•	•	
0700	NOURRICE																
0701	NOURRICE 18 INJ. BUT/PROP	60023008-01	B/P							•	•	•					
	NOURRICE 14 INJ. BUT/PROP	60041731	B/P					•	•	•	•						
	NOURRICE 12 INJ. BUT/PROP	60045685	B/P	•	•		•	•									
	NOURRICE 24 INJ. BUT/PROP	60053986	B/P											•			
	NOURRICE 18 INJ. NAT	60023008-07	NAT							•	•	•					
	NOURRICE 14 INJ. NAT	60023194-03	NAT					•	•	•	•						
	NOURRICE 12 INJ. NAT	60045686	NAT	•	•	•	•	•									
	NOURRICE 24 INJ. NAT	60053985	NAT											•			
0702	JOINT DE FORME (/Nourrice)	60033717		•	•	•	•	•	•	•	•	•	•	•	•	•	
0703	VIS M 5-25	60031035-03		•	•	•	•	•	•	•	•	•	•	•	•	•	
	VIS M 5-35	60075760-03												•	•	•	
0704	RONDELLE D: 10-5-1	60022118-03		•	•	•	•	•	•	•	•	•	•	•	•	•	
0705	VIS HX M 5-12	61010131		•	•	•	•	•	•	•	•	•	•	•	•	•	
0708	TROMPETTE	60053762	GV					•		•							
0710	JOINT DE FORME (/Nourrice)	60049777												•	•	•	
0712	VIS DE PRISE DE PRESSION	60019445												•	•	•	
0713	JOINT DE FORME (/Electrovanne)	60049778												•	•	•	
0714	SIEGES DE CLAPETS (Pochette)	60081573	B/P											•			
	SIEGES DE CLAPETS (Pochette)	60081564	NAT											•			
1000	VASE D'EXPANSION	60056676-06		•	•	•	•	•	•	•	•	•	•	•	•	•	
1001	TUBE DE VASE D'EXPANSION	60044947				•		•	•		•	•		•			
	TUBE DE VASE D'EXPANSION	60053368												•	•		
	DURIT (Pochette)	60081013			•	•											
1002	SUPPORT DE VESPI (Pochette)	60081014		•	•	•	•	•	•	•	•	•	•	•	•	•	
1003	BAGUE BICONE D: 6	60022865				•	•										
1004	VIS RACCORD BICONE	60031269			•	•											
1005	JOINT TORIQUE D: 6-1	60024164-41		•	•	•	•	•	•	•	•	•	•	•	•	•	
1100	VALVE EAU THERMOSTATIQUE	60044873		•	•	•		•	•		•	•					
	VALVE EAU THERMOSTATIQUE	60045193				•		•	•		•	•					
1102	JOINT TORIQUE D: 6-1	60024164-41		•	•	•	•	•	•	•	•	•	•	•	•	•	
1105	REFECTION VALVE EAU (Pochette)	60100605-30		•	•	•	•	•	•	•	•	•	•	•	•	•	
1106	MEMBRANE	60022171-10		•	•	•	•	•	•	•	•	•	•	•	•	•	
1109	JOINT PLAT D: 14.8-10.3-1.5	60061854-11		•	•	•	•	•	•	•	•	•	•	•	•	•	
1110	PRESSE ETOUPE	60022639		•	•	•		•	•		•	•		•	•		
1111	TUBE COMMUNICATION	60025043		•	•	•	•	•		•	•		•	•			
	TUBE COMMUNICATION	60026418				•		•	•		•	•					
1113	ECROU H M 5-0.80	60008664-13		•	•	•	•	•	•	•	•	•	•	•	•	•	
1115	TUBE DE SURPRESSION	60055985		•	•	•	•	•	•	•	•	•	•	•	•	•	
1116	TUBE DEPRESSION	60045328				•		•	•		•	•					
1117	JOINT TORIQUE D: 21.3-3.6	60024183-25		•	•	•	•	•	•	•	•	•	•	•	•	•	
1118	RACCORD M 10x100	60045582-08		•	•	•	•	•	•	•	•	•	•	•	•	•	
1119	JOINT TORIQUE D: 7.2-1.9	60024183-12		•	•	•	•	•	•	•	•	•	•	•	•	•	
1120	CIRCLIPS EXT D: 8	60020769-23		•	•	•	•	•	•	•	•	•	•	•	•	•	
1121	RACCORD M 3/8	60045581-08		•	•	•	•	•	•	•	•	•	•	•	•	•	
1122	JOINT TORIQUE D: 12.1-2.7	60024183-16		•	•	•	•	•	•	•	•	•	•	•	•	•	
1123	RACCORD SURPRESSION	60053715		•	•	•	•	•	•	•	•	•	•	•	•	•	
1124	JOINT TORIQUE D: 5.7-1.9	60024183-10		•	•	•	•	•	•	•	•	•	•	•	•	•	
1125	CLOU CANNELE D: 3-16	60042551		•	•	•	•	•	•	•	•	•	•	•	•	•	
1126	BY-PASS	60042553				•		•	•		•	•					
1127	JOINT TORIQUE D: 4.9-1.9	60024183-09				•		•	•		•	•					
1129	CLOU CANNELE D: 3-10	60042552				•		•	•		•	•					
1130	CLIP	60023537-03		•	•	•	•	•	•	•	•	•	•	•	•	•	
1131	ELEMENT THERMOSTATIQUE	60034779		•	•	•	•	•	•	•	•	•	•	•	•	•	
1132	ELEMENT DE MANOEUVRE	60034799		•	•	•	•	•	•	•	•	•	•	•	•	•	
1133	ELEMENT DE MANOEUVRE (Poch.)	60100600-30		•	•	•	•	•	•	•	•	•	•	•	•	•	
1134	JOINT TORIQUE D: 23-3.6	60024183-32		•	•	•	•	•	•	•	•	•	•	•	•	•	
1135	JOINT TORIQUE D: 7.2-1.9	60024164-12		•	•	•	•	•	•	•	•	•	•	•	•	•	
1136	VIS M 5-15	60031088-03		•	•	•	•	•	•	•	•	•	•	•	•	•	

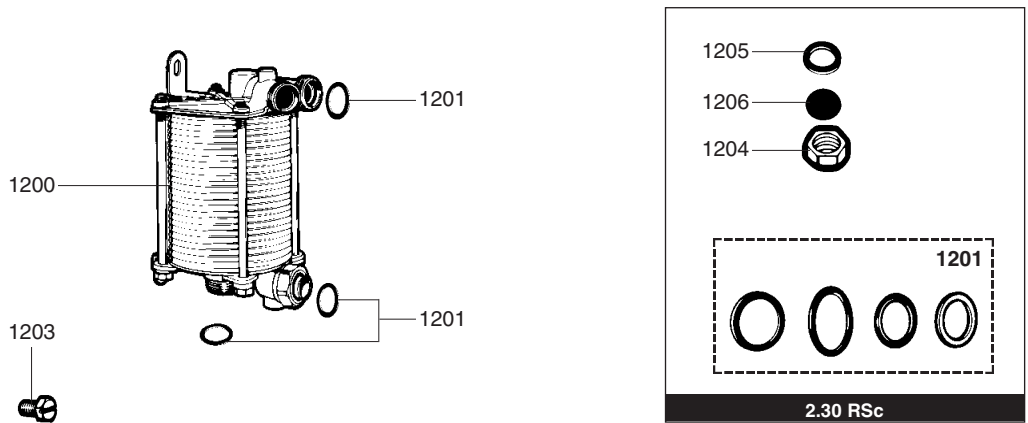
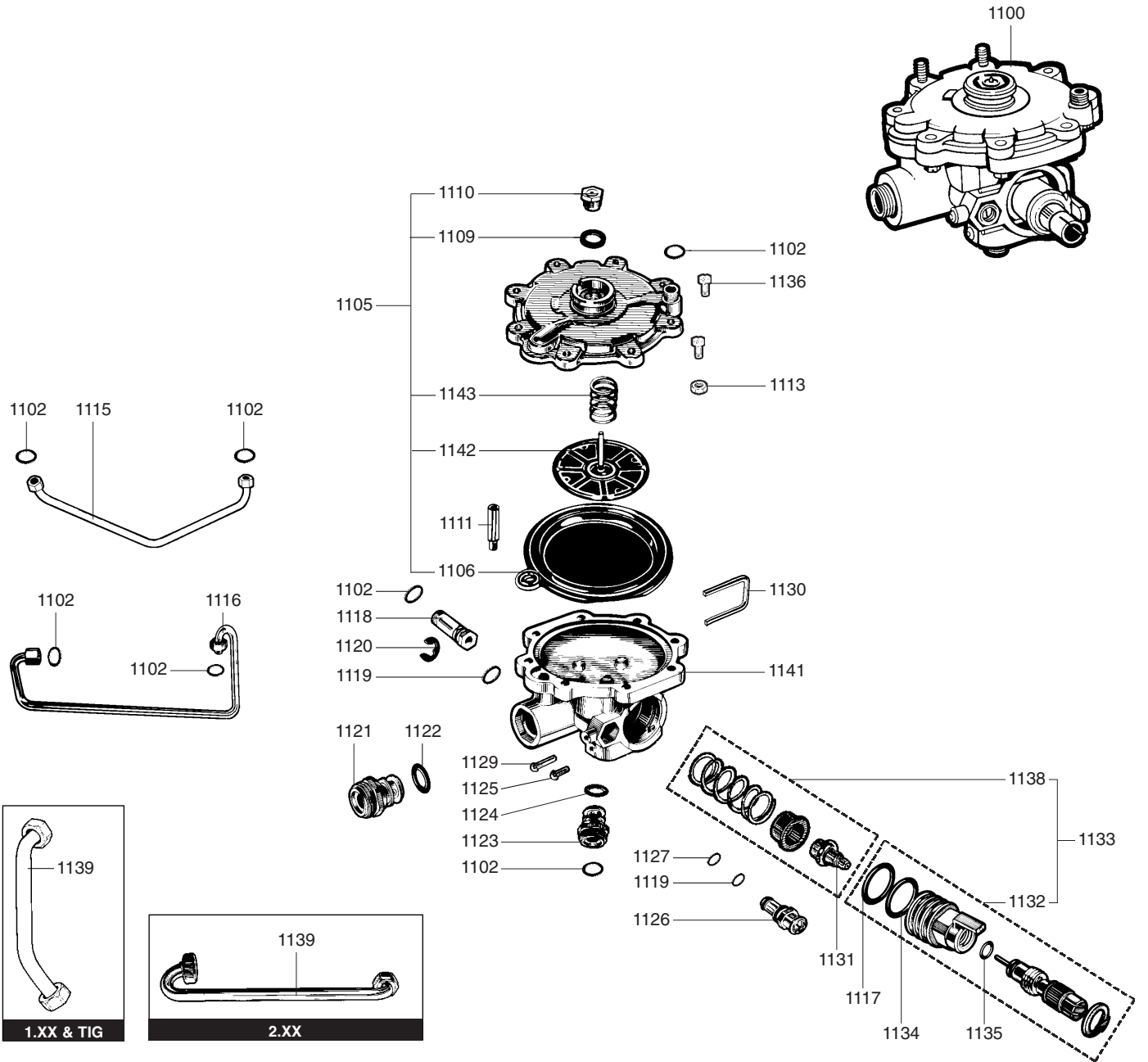

Rep.	Désignation	Référence	Type	12		16		18		20		24		30		Date															
				1-12		TIG 12		2-16		1-16		TIG 16		2-20		1-20		TIG 20		2-24		1-24		TIG 24		2-30		1-30		TIG 30	
				CF	CF	VMC	CF	CF	CF	VMC	CF	VMC	CF	CF	CF	VMC	CF	CF	CF	CF	CF	CF	CF	CF	CF	CF	CF	de	à		
1138	ELEMENT THERMOSTATIQUE (Poch.)	60100602-30		•	•	•	•	•	•	•	•	•	•	•	•																
1139	TUBE DEPRESSION	60044849					•			•	•	•		•	•																
1141	CORPS VALVE EAU	60045447					•			•	•	•		•	•																
	CORPS VALVE EAU	60045729		•	•	•		•	•				•	•		•	•														
1142	PLATEAU DE MEMBRANE	60022158		•	•	•	•	•	•	•	•	•	•	•	•	•	•														
1143	RESSORT 18.5 x 1.5 L: 30	60020981		•	•	•	•	•	•	•	•	•	•	•	•	•															
1200	ECHANGEUR SANITAIRE 24 C KIT	61001974							•	•	•		•	•																	
	ECHANGEUR SANITAIRE 20 C KIT	61001975					•																								
	ECHANGEUR SANITAIRE 20 C KIT	61001977																													
1201	JOINT TORIQUE D: 16-1.9	60024183-37					•			•	•	•		•	•																
	JOINTS ECHANGEUR SANIT (Poch.)	60081215																													
1203	VIS HS M 8-16	60031519-03					•			•	•	•		•	•																
1204	ECROU 3/8" EP: 11	60020746-20																													
1205	JOINT CUIVRE D:15-10-1.5	60046451																													
1206	DISQUE OBTURATEUR	60001219																													
1208	RACCORD M 3/4 F 1/2	60048257					•			•	•	•		•	•																

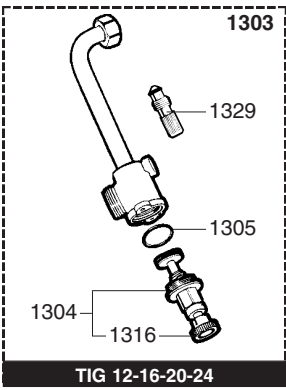

TIG 12-16-20-24

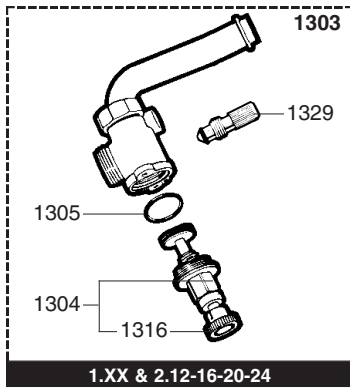

1.XX & 2.12-16-20-24

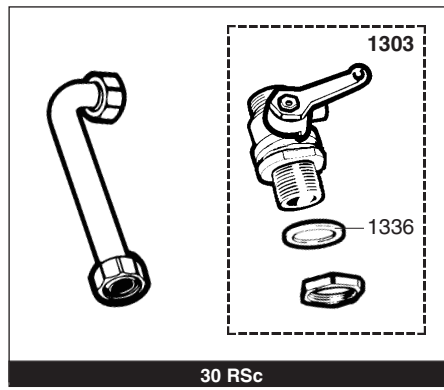

30 RSc

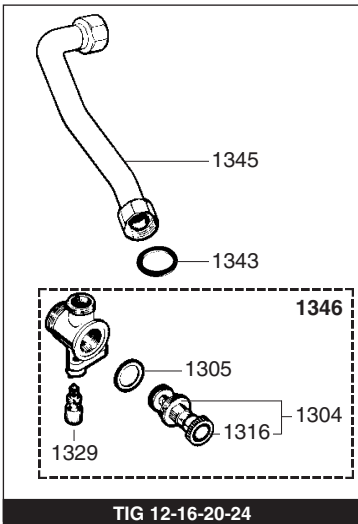

TIG 12-16-20-24

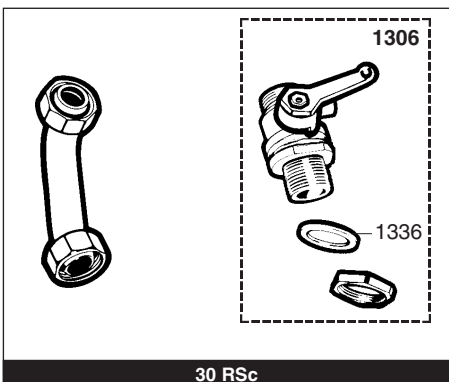
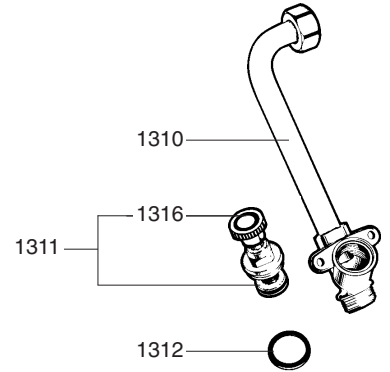
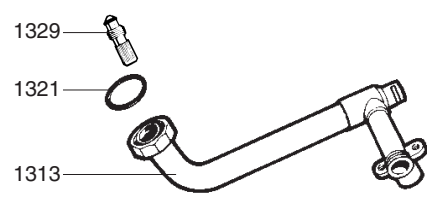
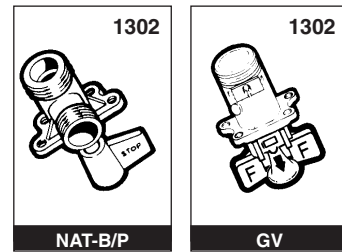
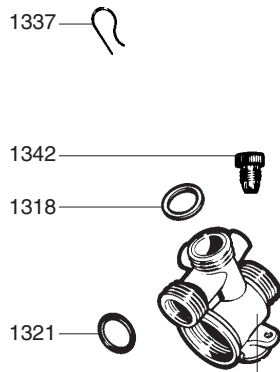
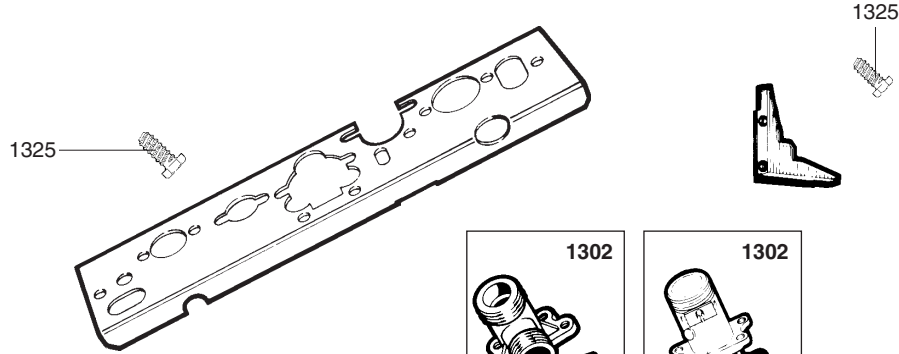

30 RSc

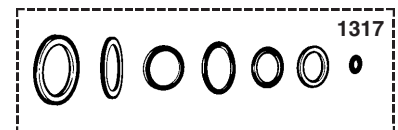

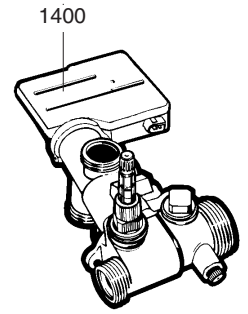
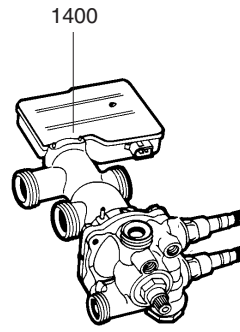
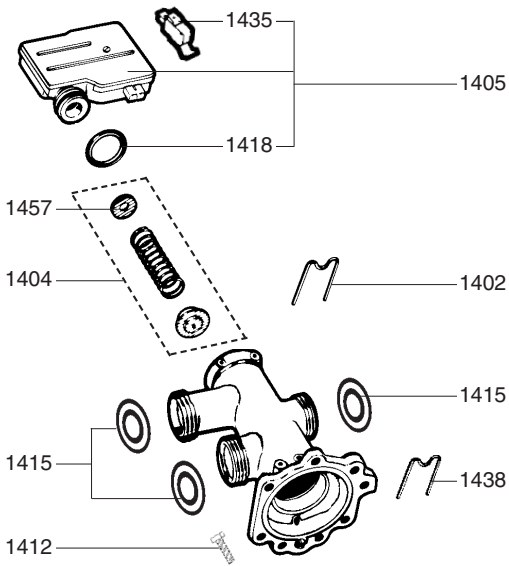

- 1427
- 1409
- 1408

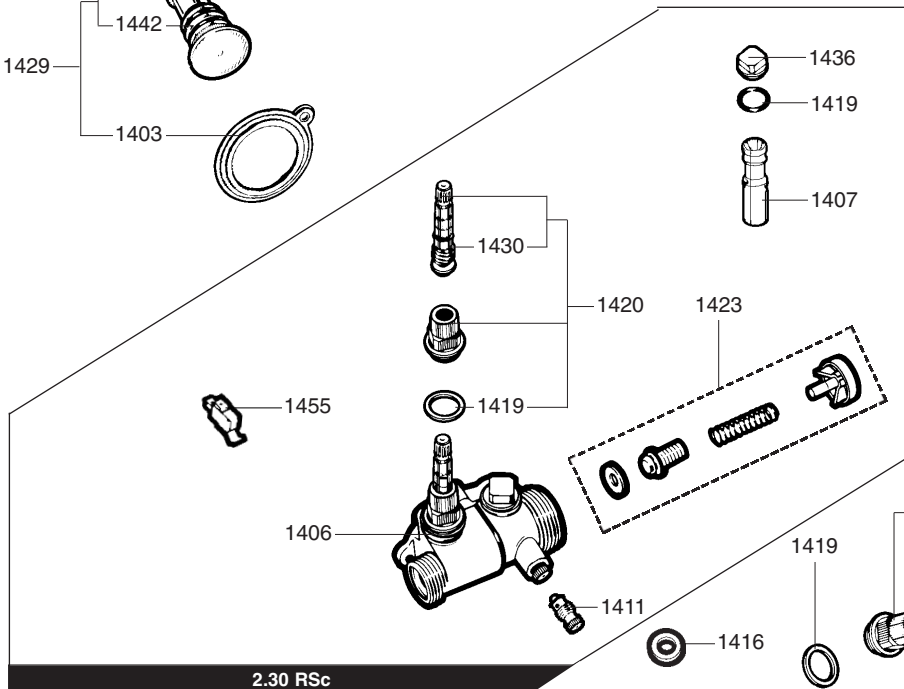
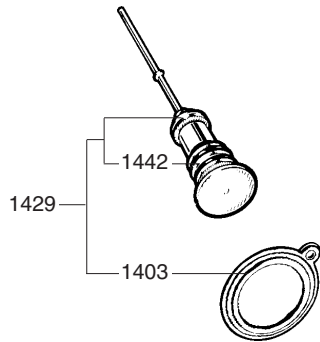
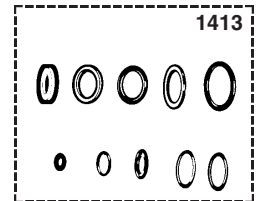

2.30 RSc

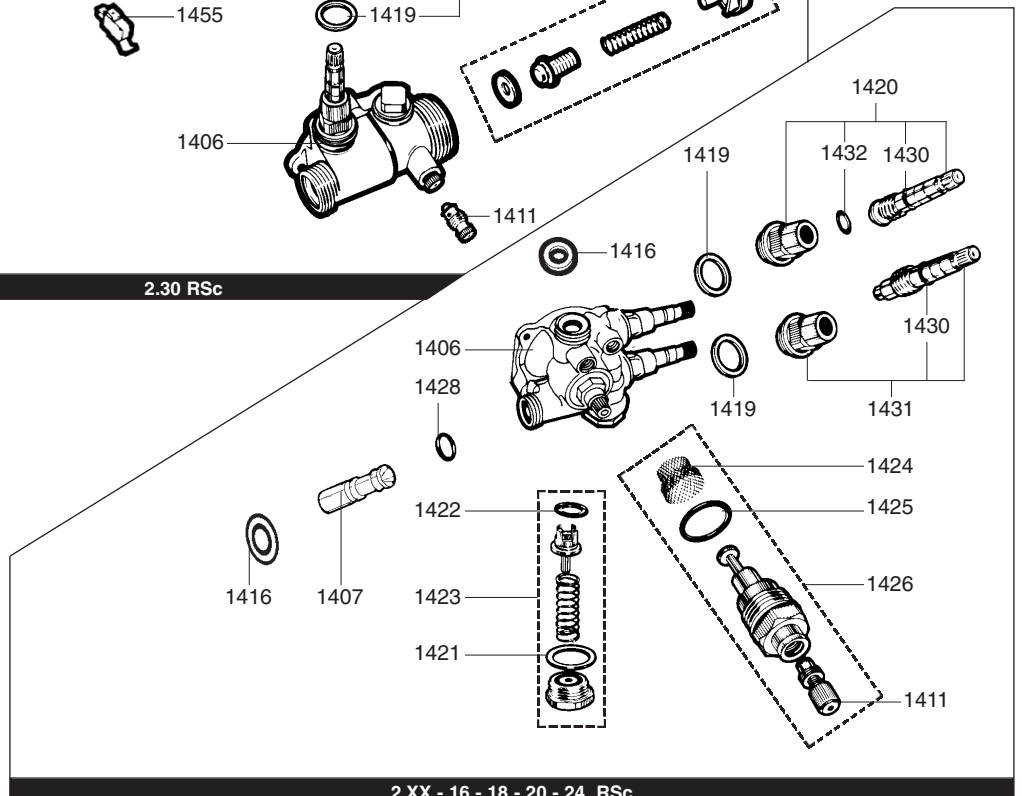

2.XX - 16 - 18 - 20 - 24 RSc

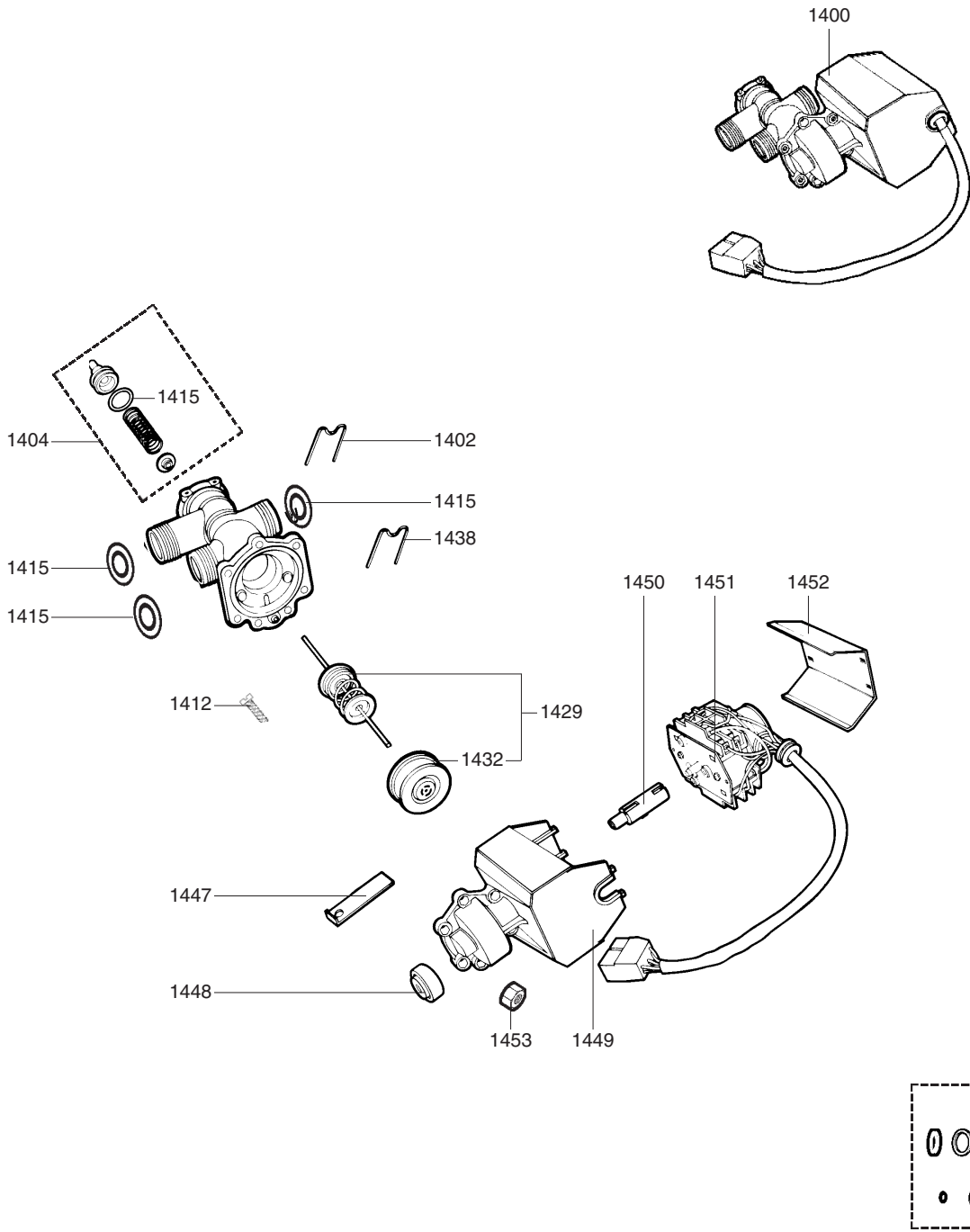

Rep.	Désignation	Référence	Type	12		16		18		20		24		30		Date	
				1-12		1-16		1-18		1-20		1-24		1-30		de	à
				CF	VMC	CF	VMC	CF	VMC	CF	VMC	CF	VMC	CF	VMC		
1400	VALVE DISTRIBUTRICE TI	60045652		•	•			•				•			•		
1402	CLIP	60031764		•	•			•				•			•		
1404	CLAPET (Pochette)	60081513		•	•			•				•			•		
1412	VIS H M 5-20	60019317		•	•			•				•			•		
1413	JOINTS VALVE DISTRIBUT (Poch.)	60081176		•	•			•				•			•		
1415	JOINT TORIQUE D: 19.8-3.6	60024164-24		•	•			•				•			•		
1429	CLAPET CHAUFFAGE (Pochette)	60081514		•	•			•				•			•		
1432	JOINT TORIQUE D: 25-2.4	60024164-32		•	•			•				•			•		
1438	CLIP	60025076-03		•	•			•				•			•		
1447	LAME VD TI	60026206		•	•			•				•			•		
1448	CAME MANOEUVRE	60026203		•	•			•				•			•		
1449	CARTER MOTO REDUCTEUR	60026003		•	•			•				•			•		
1450	AXE CAME	60026202		•	•			•				•			•		
1451	MOTEUR REDUCTEUR	60045350		•	•			•				•			•		
1452	COUVERCLE COTE MOTEUR	60026207		•	•			•				•			•		
1453	ECROU H M 5-0.80	60008664-13		•	•			•				•			•		

1500

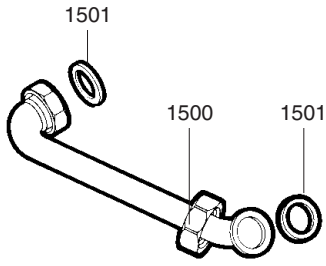

1600

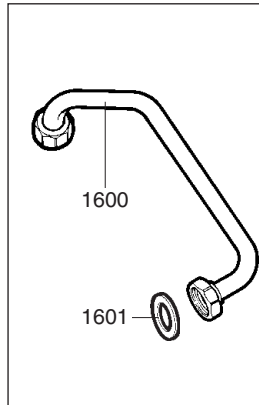
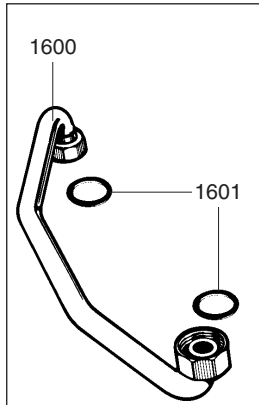

12-16-18-20-24 RSc

30 RSc

2000

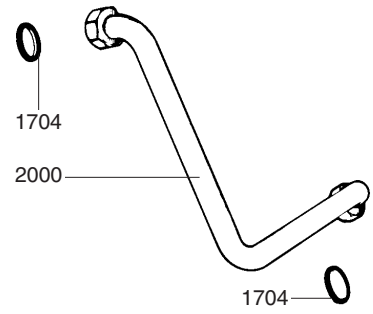

1700

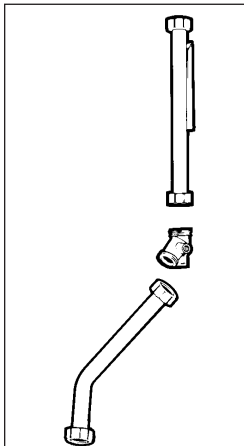
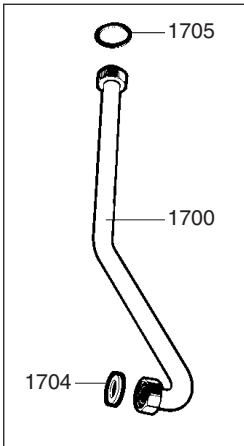

12-16-18-20-24 RSc

1.30 RSc

1900

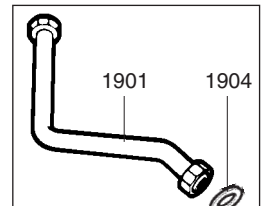
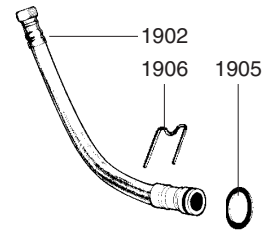
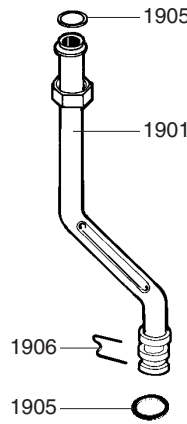

30 RSc

2100

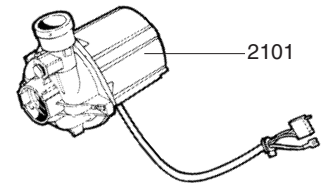
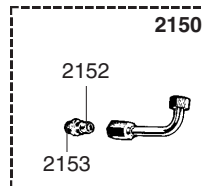
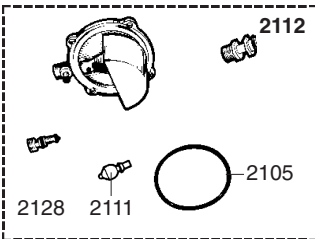
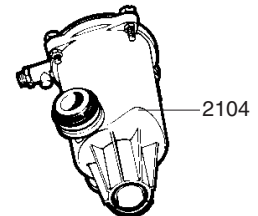
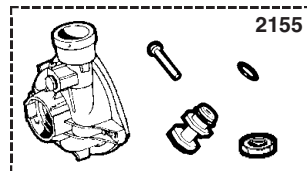

2102 2103

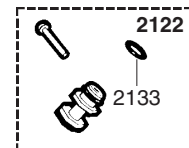

2120

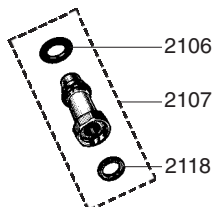
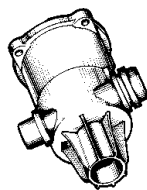

2116

2109

2134

2121

2115

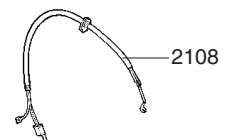

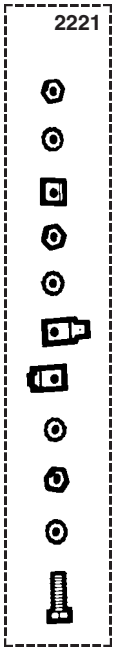

2221

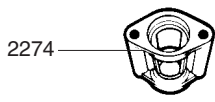

2274

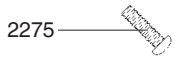

2275



2253



2222

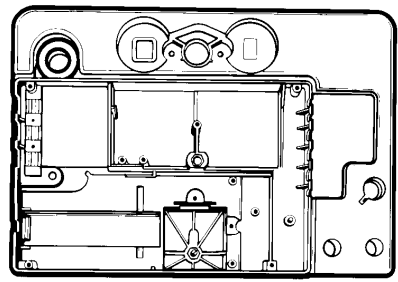
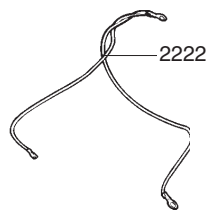

2212



2205



2207



2246



2258

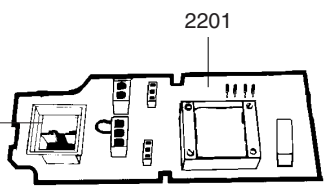

2201

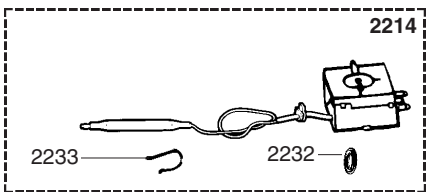

2214

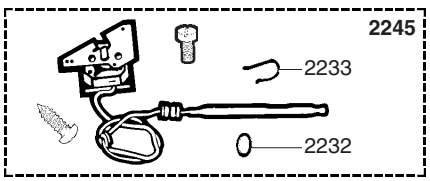

2245



2215

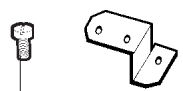

2265



2208

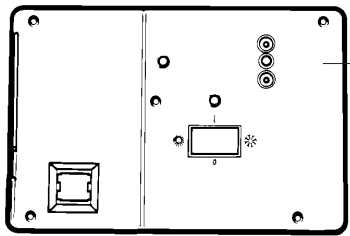

2240

2225

2249

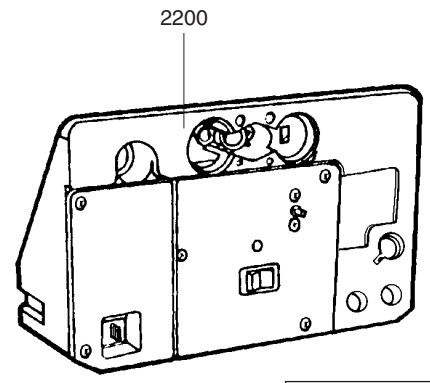

2200



2247



2248



2249



2277



2236



2250



2249

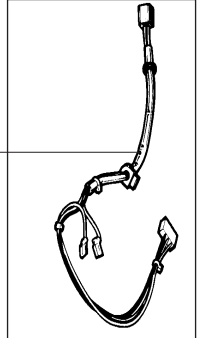

2219

12-16-20-24 RSC

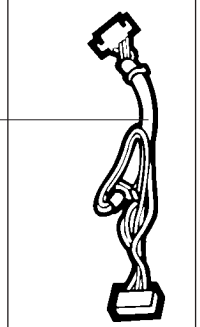

2219

2.30 RSC



2220



2252

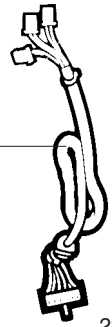

2264



2226

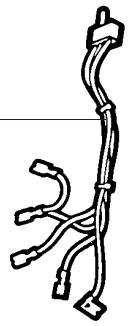

Rep.	Désignation	Référence	Type	12		16		18		20		24		30		Date															
				1-12		TIG 12		2-16		1-16		TIG 16		2-20		1-20		TIG 20		2-24		1-24		TIG 24		2-30		1-30		TIG 30	
				CF	CF	VMC	CF	CF	CF	VMC	CF	VMC	CF	CF	CF	VMC	CF	CF	CF	CF	CF	CF	CF	CF	CF	CF	CF	CF	de	à	
2200	BOITIER ELECTRIQUE	60053326	NOTA 1																												
2201	CIRCUIT IMPRIME	60045216																													
	CIRCUIT IMPRIME	60045263																													
	CIRCUIT IMPRIME	60045304																													
	CIRCUIT IMPRIME	60045317																													
	CIRCUIT IMPRIME	60054481																													
	CIRCUIT IMPRIME	60055898																													
	CIRCUIT IMPRIME	60056720																													
2205	SUPPORT FUSIBLE	60044799-10																													
2206	CAPOT DE PROTECTION	60044800-10																													
2207	FUSIBLE 220V 630mA	60045234																													
2208	ALLUMEUR	60034269																													
2212	CONDENSATEUR 2 MF	60028463																													
2214	AQUASTAT 57°C (Pochette)	60100606-30																													
2215	THERMOSTAT CHAUFFAGE 85°C	60056974																													
2219	CABLAGE VALVE DISTRI./AQUASTAT	60046466																													
	CABLAGE VALVE DISTRIBUTRICE	60054615																													
2220	CABLAGE ELECTROVANNES	60054639																													
	CABLAGE ELECTROVANNES	60054716																													
2221	VIS DE MASSE (Pochette)	60081169																													
2222	CABLAGE DE MASSE	60053319																													
2225	INTERRUPTEUR NOIR	60074094																													
2226	CABLAGE INTER-CHRONO	60045322																													
	CABLAGE INTER-CHRONO	60045459																													
2232	JOINT TORIQUE D: 7.2-1.9	60024164-12																													
2233	CLIP	60031546																													
2236	PASSE FIL	60027837																													
2240	COUVERCLE BOITIER ELECTRIQUE	60053815																													
	COUVERCLE BOITIER ELECTRIQUE	60047796	NOTA 1																												
	COUVERCLE BOITIER ELECTRIQUE	60047797	NOTA 2																												
2245	THERMOSTAT REGLABLE (Pochette)	60081420																													
2246	CHRONORUPTEUR 14H	60030697	NOTA 1																												
2249	VIS F90Z D: 3.5-16	61004804-20																													
2250	PASSE FIL	60027838																													
2252	CABLAGE AQUASTAT	60054713																													
	CABLAGE AQUASTAT	60069047																													
2253	VIS A TOLE CBLX D: 6.3-13	61010648																													
2258	VIS M 4-6	60019197-03	NOTA 1																												
2264	THERMOSTAT 60°C ENS	60079854																													
2265	VIS A TOLE CBLZ D: 3.5-9.5	60054033																													
2274	ENTRETOISE	60044556	NOTA 2																												
2275	VIS HS M 6-15	60019316-03	NOTA 1																												

NOTA 1 : CELTIC
NOTA 2 : GM

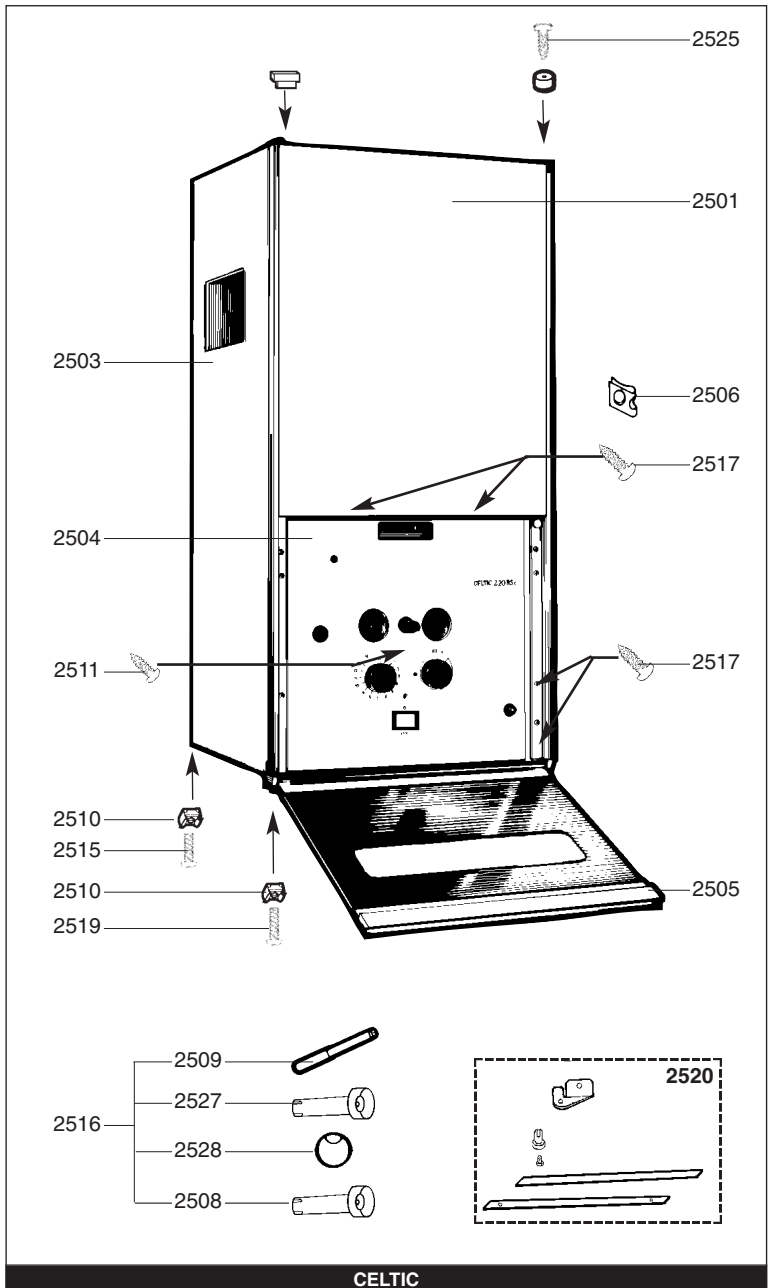
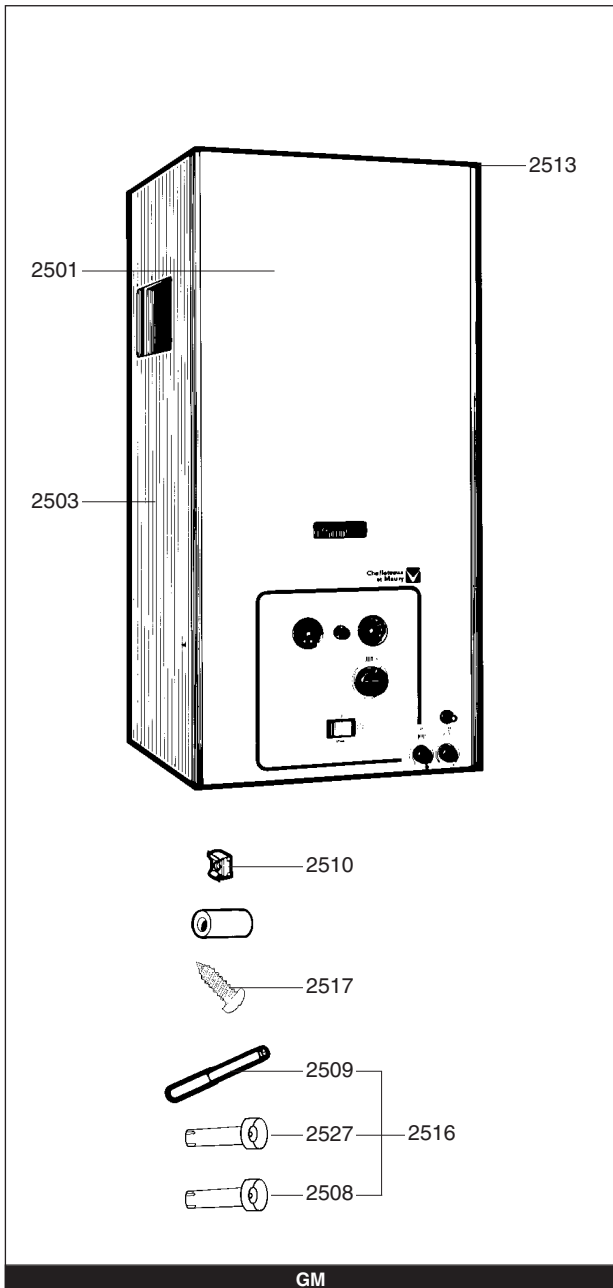
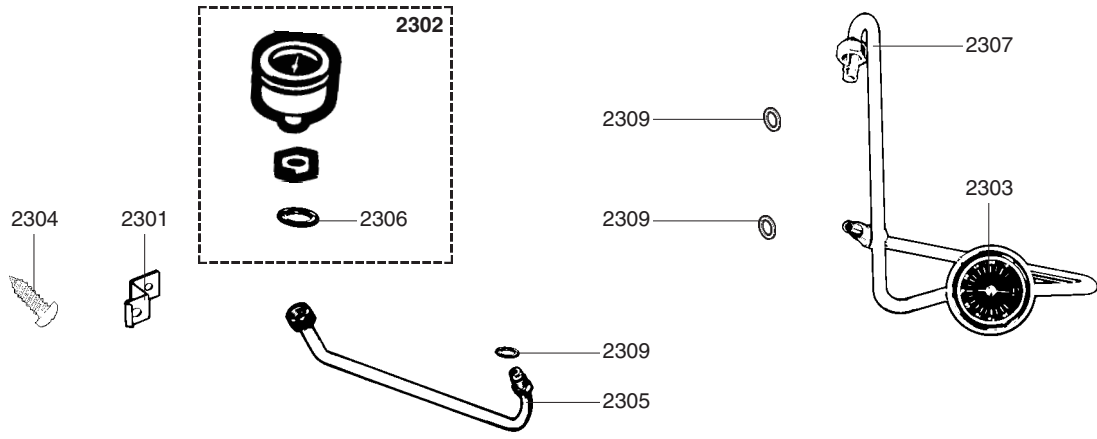

Rep.	Désignation	Référence	Type	12		16		18		20		24		30		Date	
				TIG 12		TIG 16		TIG 18		TIG 20		TIG 24		TIG 30		de	à
				CF	VMC	CF	VMC	CF	VMC	CF	VMC	CF	VMC	CF	VMC		
2300	AFFICHAGE																
2301	PATTE SUPPORT	60070284		●	●	●	●	●	●	●	●	●	●	●	●		
2302	MANOMETRE EQUIPE (Pochette)	60081180		●	●	●	●	●	●	●	●	●	●	●	●		
2303	THERMOMETRE	60044333	NOTA 1	●	●	●	●	●	●	●	●	●	●	●	●		
	THERMOMETRE	60044333	NOTA 2	●	●	●	●	●	●	●	●	●	●	●	●		
2304	VIS A TOLE CBLZ D: 3.5-6.5	60031521-03		●	●	●	●	●	●	●	●	●	●	●	●		
	VIS A TOLE CBLX D: 6.3-13	61010648											●	●	●		
2305	TUBE MANOMETRE	61000254	NOTA 3	●	●	●	●	●	●	●	●	●	●	●	●		
	TUBE MANOMETRE	61000257	NOTA 4	●	●	●	●	●	●	●	●	●	●	●	●		
2306	JOINT PLAT D: 8.5-4.1-1.5	60061852-12		●	●	●	●	●	●	●	●	●	●	●	●		
2307	TUBE THERMOMETRE	60054028											●				
	TUBE THERMOMETRE	60045341	NOTA 3			●		●	●	●	●	●					
	TUBE THERMOMETRE	60045343	NOTA 4			●		●	●	●	●	●					
	TUBE THERMOMETRE	60048474	NOTA 4	●		●											
2309	JOINT TORIQUE D: 6-1	60024164-41		●	●	●	●	●	●	●	●	●	●	●	●		
2500	HABILLAGE																
2501	PANNEAU AVANT	60044229-06	NOTA 3								●	●	●				
2503	PANNEAU COTE GAUCHE	60044201	NOTA 3	●	●	●	●	●	●	●	●	●	●	●	●		
	PANNEAU COTE GAUCHE	60059197	NOTA 3		●												
2504	ECRAN SERIGRAPHIE TIG 12-20RSc	60045588	NOTA 3	●	●					●							
	ECRAN SERIGRAPHIE 2.24 RSc Fra	60045593	NOTA 3							●	●						
2505	PORTE ENS	60046691	NOTA 3										●	●	●		
2506	ECROU A PINCER	60063603	NOTA 3	●	●	●	●	●	●	●	●	●	●	●	●		
2508	BOUTON VALVE DISTRIBUT. BLEU	60044267	NOTA 3			●		●	●	●	●	●	●	●			
	BOUTON VALVE DISTRIBUT. BLEU	60044268	NOTA 4			●		●	●	●	●	●	●	●			
2509	BOUTON POUSSOIR GAZ BLEU	60044263	NOTA 3	●	●	●	●	●	●	●	●	●	●	●	●		
	BOUTON POUSSOIR GAZ BLEU	60044264	NOTA 4	●	●	●	●	●	●	●	●	●	●	●	●		
2510	ECROU EN CAGE M 6	60004806-03		●	●	●	●	●	●	●	●	●	●	●	●		
2511	VIS CLS M 6-14	60014044	NOTA 3	●	●	●	●	●	●	●	●	●	●	●	●		
2515	VIS M 6-10	60031527-03	NOTA 3	●	●	●	●	●	●	●	●	●	●	●	●		
2516	BOUTONS (POCHETTE)	60100040-10	NOTA 3			●		●	●	●	●	●	●	●			
	BOUTONS (POCHETTE)	60100042-30	NOTA 4			●		●	●	●	●	●	●	●			
2517	VIS A TOLE CBLX D: 4.2-9.5	61010125		●	●	●	●	●	●	●	●	●	●	●	●		
2519	VIS HS M 6-15	60019316-03	NOTA 3	●	●	●	●	●	●	●	●	●	●	●	●		
2520	REFECTION CHARNIERE (Pochette)	60081411	NOTA 3										●	●	●		
	REFECTION CHARNIERE (Pochette)	60081418	NOTA 3	●	●	●	●	●	●	●	●	●	●	●	●		
	REFECTION CHARNIERE (Pochette)	60081494	NOTA 3										●	●	●		
2525	VIS A TOLE CBLZ D: 3.9-9.5	60050460-03	NOTA 3	●	●	●	●	●	●	●	●	●	●	●	●		
2527	BOUTON VALVE THERMOSTA. BLEU	60044265	NOTA 3	●		●	●	●	●	●	●	●	●	●	●		
	BOUTON VALVE THERMOSTA. BLEU	60044266	NOTA 4	●		●	●	●	●	●	●	●	●	●	●		
2528	BOUTON DE MANOEUVRE BLEU	60044269	NOTA 3	●	●	●	●	●	●	●	●	●	●	●	●		

NOTA 1 : TUBE D: 6
NOTA 2 : TUBE D: 8

NOTA 3 : CELTIC
NOTA 4 : GM

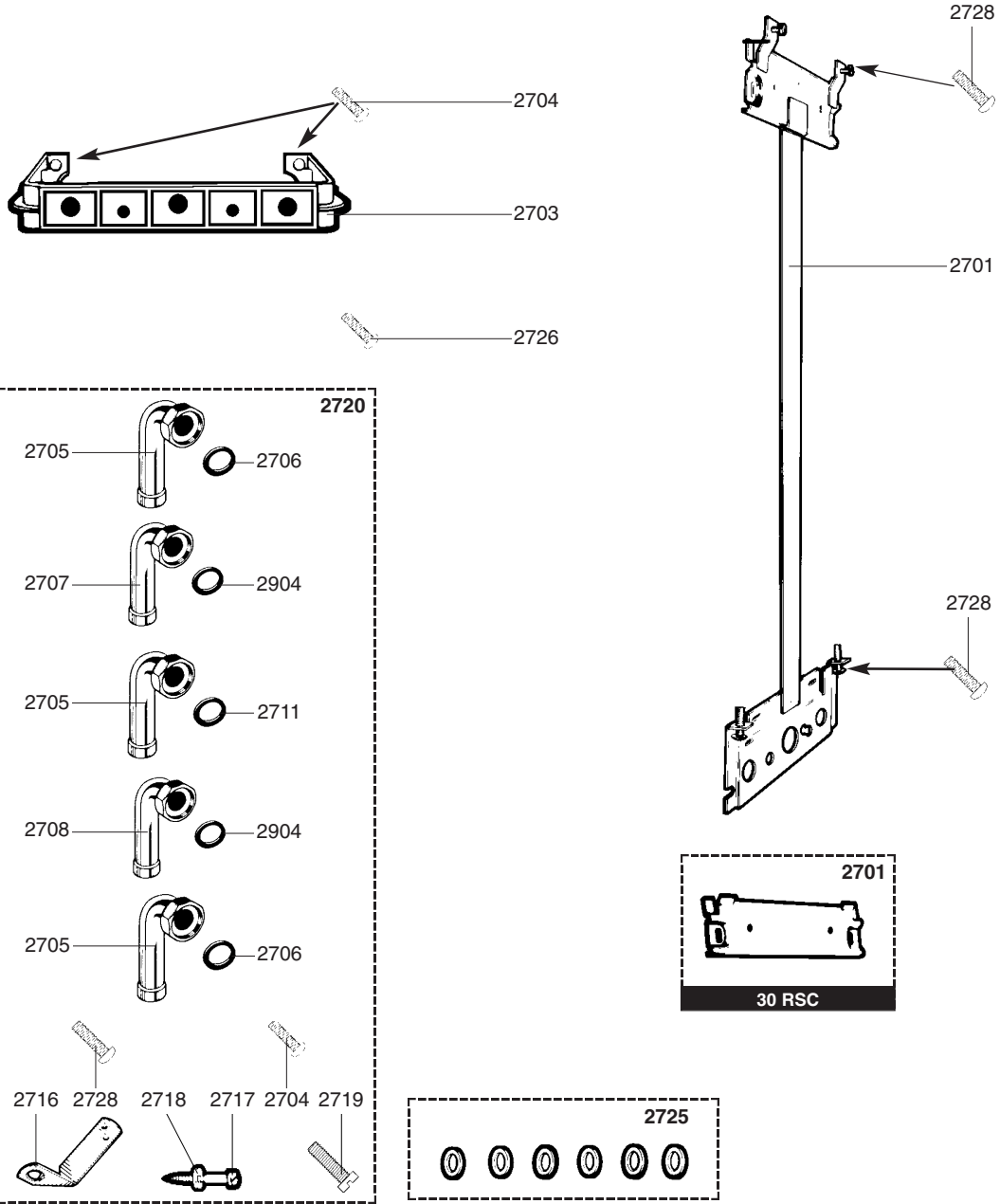

2900

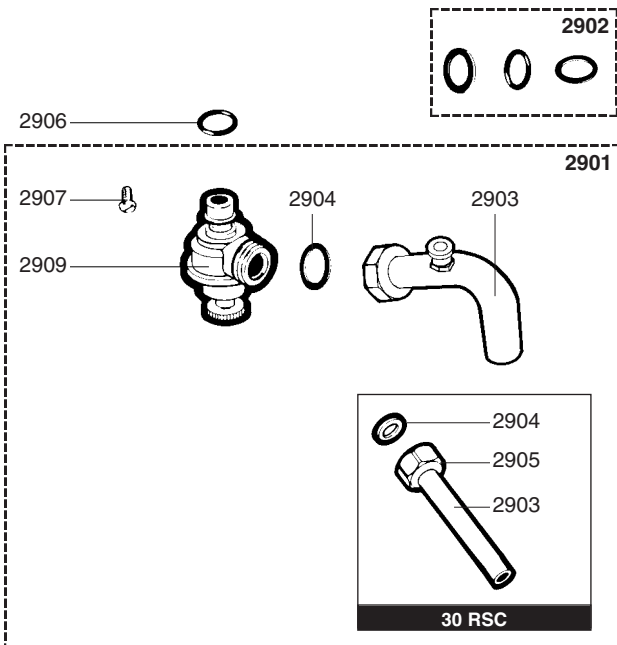

5000

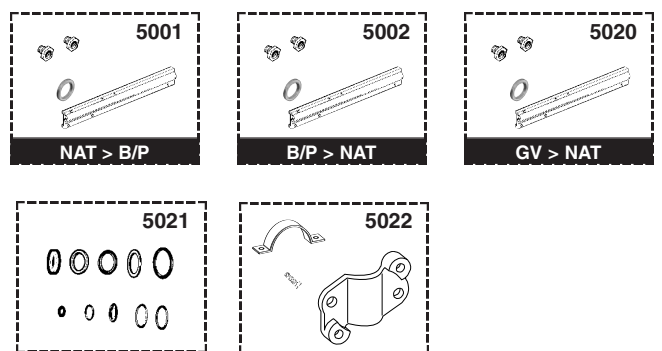

Rep.	Désignation	Référence	Type	12		16		18		20		24		30		Date	
				TIG 12		TIG 16		TIG 18		TIG 20		TIG 24		TIG 30		de	à
				CF	VMC	CF	VMC	CF	VMC	CF	VMC	CF	VMC	CF	VMC		
2700	PREFABRICATION																
2701	PLATINE D'ACCROCHAGE	60025182															
2703	GABARIT DE POSE	60057161															
2704	VIS M 6-10	60031527-03															
2705	DOUILLE DE RACCORDEMENT	60055675															
	DOUILLE DE RACCORDEMENT GAZ	60055676															
	DOUILLE DE RACCORDEMENT	60057167	B/P														
	DOUILLE DE RACCORDEMENT	60057167	NAT														
2706	JOINT PLAT D: 24-18.2-1.5	60061855-01															
	JOINT PLAT D: 24-17-1.5	60061855-19															
2707	DOUILLE DE RACCORDEMENT EF	60057169															
2708	DOUILLE DE RACCORDEMENT EC	60055674															
	DOUILLE DE RACCORDEMENT EC	60057168															
2711	JOINT PLAT D: 24-16.2-1.5	60022835-02															
	JOINT PLAT D: 24-18.2-1.5	60022835-01	B/P														
	JOINT PLAT D: 29.9-24.4-1.5	60022834-02	GV														
	JOINT PLAT D: 24-18.2-1.5	60022835-01	NAT														
2715	ECROU 3/4"	60020748-68															
2717	VIS A BOIS D:6-38	60025617-03															
2718	RONDELLE D: 14.2-7.2-1.2	60005369-03															
2720	RACCORDEMENT (POCHETTE)	60079918															
2725	JOINTS PREFABRICATION (Poch.)	60081062															
2726	VIS A TOLE CBLX D: 4.2-9.5	61010125															
2728	VIS HS M 6-25	60010942-13															
2900	SOUPAPE																
2901	SOUPAPE DE SECURITE (Pochette)	61001900															
2902	REFECTION SOUPAPE (Pochette)	60081025															
2903	DOUILLE RACCORDEMENT SOUPAPE	60031953															
2904	JOINT PLAT D: 18.4-12.2-1.5	60061855-14															
2905	ECROU 1/2" EP: 10	60020747-68															
2906	JOINT TORIQUE D: 13.6-2.7	60024164-18															
2907	VIS A TETON M5	60017908															
2909	SOUPAPE DE SECURITE 3 BARS	61020933															
5000	OPTIONS																
5001	EQT TRANSF NAT > BUT/PROP	60311615-91															
	EQT TRANSF NAT > BUT/PROP	60311625-91															
	EQT TRANSF NAT > BUT/PROP	60311821-91															
	EQT TRANSF NAT > BUT/PROP	60311822-91															
5002	EQT TRANSF BUT/PROP > NAT	60311613-81															
	EQT TRANSF BUT/PROP > NAT	60311625-81															
	EQT TRANSF BUT/PROP > NAT	60311821-81															
	EQT TRANSF BUT/PROP > NAT	60311822-81															
5020	EQT TRANSF GV > NAT	60311614-51															
5021	JOINTS (Pochette)	60100421-10															
5022	ADAPTATION (EQT)	60035428															
5024	SECURITE 110°C (Pochette)	60100346-30															

