

SPARE PARTS EXPLODED VIEW GAS WALL BOILERS

Model

URBIA - SERELIA

R8203078-10 - 12/03/2012

| | | | | |
|----|---------|----------------------|-------|-------|
| 1 | 3650158 | URBIA 25 CF N FR | 08/07 | 02/10 |
| 1 | 3310089 | URBIA 25 CF N FR | 03/10 | ... |
| 1 | 3650159 | URBIA 25 CF B/P FR | 08/07 | ... |
| 2 | 3650163 | URBIA 30 CF N FR | 08/07 | 01/10 |
| 2 | 3310109 | URBIA 30 CF N FR | 02/10 | ... |
| 3 | 3650160 | URBIA 24 VMC N FR | 08/07 | 02/10 |
| 3 | 3310082 | URBIA 24 VMC N FR | 03/10 | ... |
| 4 | 3650161 | URBIA 25 FF N FR | 08/07 | 01/10 |
| 4 | 3310081 | URBIA 25 FF N FR | 02/10 | ... |
| 4 | 3650162 | URBIA 25 FF B/P FR | 08/07 | ... |
| 5 | 3650165 | URBIA 30 FF N FR | 08/07 | 04/10 |
| 5 | 3310106 | URBIA 30 FF N FR | 05/10 | ... |
| 6 | 3650167 | URBIA 35 FF N FR | 08/07 | ... |
| 6 | 3310118 | URBIA 35 FF N FR | ... | ... |
| 7 | 3650149 | SERELIA 25 CF N FR | 09/07 | 01/10 |
| 7 | 3310096 | SERELIA 25 CF N FR | 02/10 | ... |
| 7 | 3650150 | SERELIA 25 CF B/P FR | 09/07 | ... |
| 8 | 3650154 | SERELIA 30 CF N FR | 09/07 | 05/10 |
| 8 | 3310115 | SERELIA 30 CF N FR | 06/10 | ... |
| 9 | 3650151 | SERELIA 24 VMC N FR | 09/07 | 01/10 |
| 9 | 3310094 | SERELIA 24 VMC N FR | 02/10 | ... |
| 10 | 3650152 | SERELIA 25 FF N FR | 09/07 | 06/10 |
| 10 | 3310095 | SERELIA 25 FF N FR | 07/10 | ... |
| 10 | 3650153 | SERELIA 25 FF B/P FR | 09/07 | ... |
| 11 | 3650156 | SERELIA 30 FF N FR | 09/07 | 06/10 |
| 11 | 3310117 | SERELIA 30 FF N FR | 07/10 | ... |
| 12 | 3650157 | SERELIA 35 FF N FR | 09/07 | ... |

| Col | Reference | Model type | Begin | End |
|-----|-----------|------------|-------|-----|
|-----|-----------|------------|-------|-----|

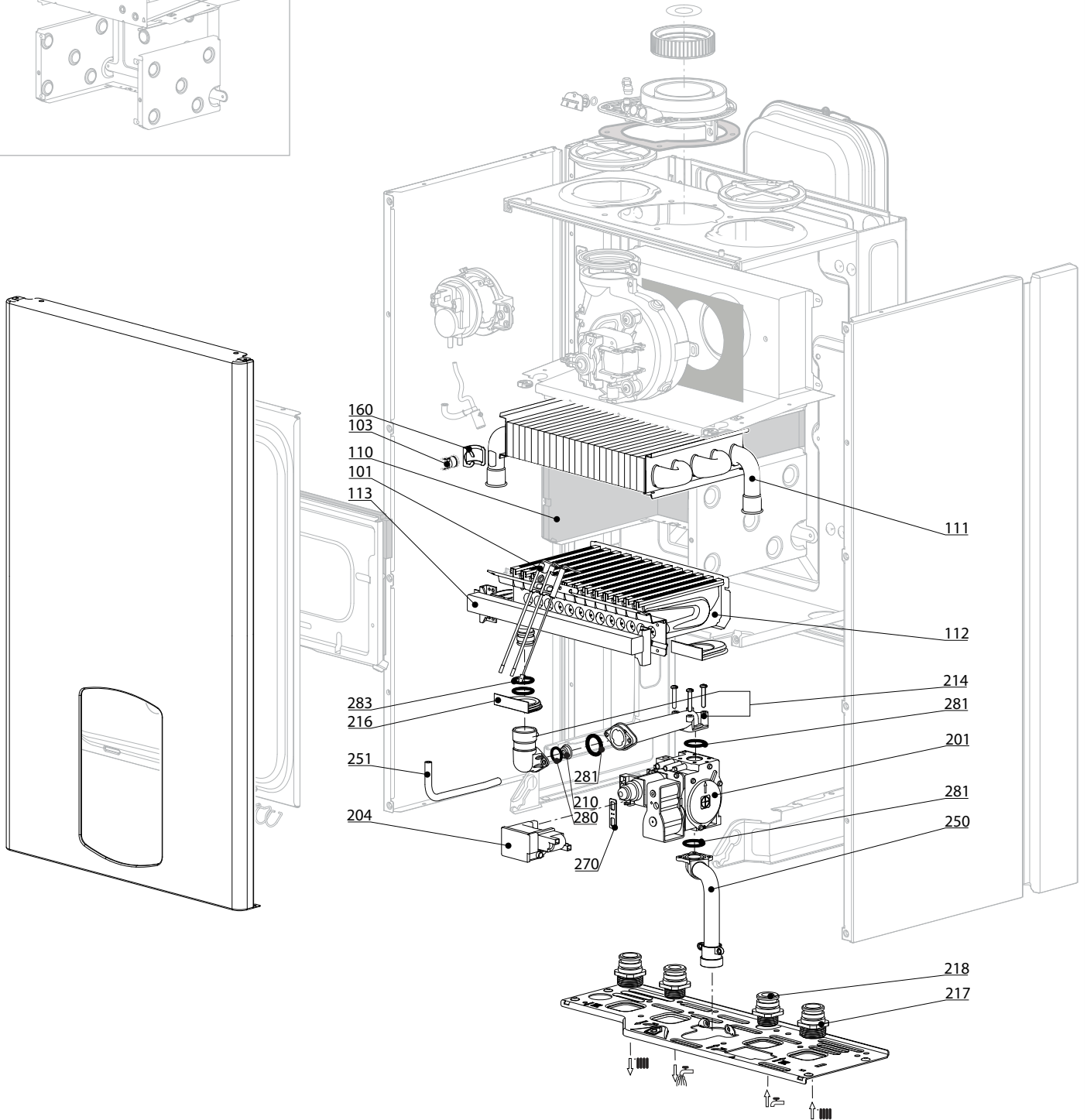
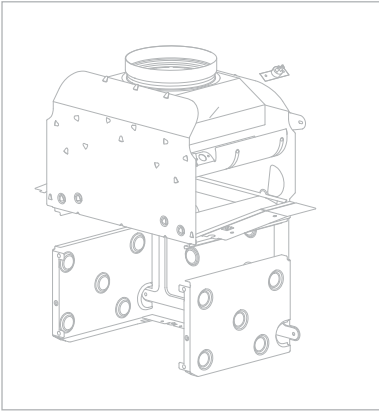

| ☰ | Description | Manf. Pt. N | Type | <div style="display: flex; justify-content: space-between; font-size: small;"> URBIA 23 CFURBIA 30 CFURBIA 24 VMCURBIA 23 FFURBIA 30 FFSERELIA 23 FFSERELIA 23 CFSERELIA 30 CFSERELIA 24 VMCSERELIA 23 FFSERELIA 30 FF </div> | | | | | | | | | | | | | | | | | | 31 |
|-------------|--------------------------------|-------------|------|--|---|---|---|---|---|---|---|---|----|----|----|----|----|----|-------|----|----|----|
| | | | | 1 | 2 | 3 | 4 | 5 | 6 | 7 | 8 | 9 | 10 | 11 | 12 | 13 | 14 | 15 | 16 | 17 | 18 | |
| 0100 | BURNER ASSEMBLY | | | | | | | | | | | | | | | | | | | | | |
| 0101 | ELECTRODE (IGNITION/DETECTION) | 65104549 | | • | • | • | • | • | • | • | • | • | • | • | • | | | | | | | |
| 0103 | THERMOSTAT 102° | 65104500 | | • | • | • | • | • | • | • | • | • | • | • | • | | | | | | | |
| 0110 | PANELS (KIT) | 65104695 | | | | | • | | | | | • | | | | | | | 02/08 | | | |
| | PANELS (KIT) | 65104695 | | • | | • | | • | | • | | • | | | | | | | | | | |
| | PANELS (KIT) | 65105029 | | | • | | | • | | • | | | • | | | | | | | | | |
| | PANELS (KIT) | 65106298 | | | | | • | | | | | • | | | | | | | 03/08 | | | |
| 0111 | MAIN EXCHANGER | 65104246 | | | | | • | | | | | • | | | | | | | 02/08 | | | |
| | MAIN EXCHANGER | 65104246 | | | | | • | | | | | • | | | | | | | | | | |
| | MAIN EXCHANGER | 65104247 | | • | | • | | | | • | | • | | | | | | | | | | |
| | MAIN EXCHANGER | 65105030 | | | • | | | | | • | | | | | | | | | | | | |
| | MAIN EXCHANGER | 65105041 | | | | | | • | | | | | | | | • | | | | | | |
| | MAIN EXCHANGER | 65106297 | | | | | • | | | | | • | | | | | | | 03/08 | | | |
| 0112 | BURNER 16NP | 60001596 | | | | | | | • | | | | | | | • | | | 01/11 | | | |
| | BURNER 13NP | 65104220 | | | | | • | | | | | • | | | | | | | 02/08 | | | |
| | BURNER 13NP | 65104220 | | • | | • | | • | | • | | • | | • | | | | | | | | |
| | BURNER 15NP | 65105027 | | | | | | | • | | | | | | | | • | | 02/08 | | | |
| | BURNER 15NP | 65105027 | | | • | | | | | • | | | | | | | | | | | | |
| | BURNER 11NP | 65106294 | | | | | • | | | | | • | | | | | | | 03/08 | | | |
| | BURNER 16NP | 65106431 | | | | | | | • | | | | | | | • | | | 03/08 | | | |
| 0113 | GAS MANIFOLD 13 INJ. D:0.76 | 65104223 | LPG | | | | • | | | | | • | | | | | | | 02/08 | | | |
| | GAS MANIFOLD 13 INJ. D:0.76 | 65104223 | LPG | • | | | | | | • | | | | | | | | | | | | |
| | GAS MANIFOLD 11 INJ. D:0.80 | 65106605 | LPG | | | | • | | | | | • | | | | | | | 03/08 | | | |
| | GAS MANIFOLD 16 INJ. D:1.32 | 60001597 | NAT | | | | | | • | | | | | | | • | | | 01/11 | | | |
| | GAS MANIFOLD 13 INJ. D:1.32 | 65104226 | NAT | | | | | • | | | | | | | | • | | | | | | |
| | GAS MANIFOLD 13 INJ. D:1.25 | 65104302 | NAT | | | | • | | | | | • | | | | | | | 02/08 | | | |
| | GAS MANIFOLD 13 INJ. D:1.25 | 65104302 | NAT | • | | • | | | | • | | • | | | | | | | | | | |
| | GAS MANIFOLD 15 INJ. D:1.25 | 65105026 | NAT | | • | | | | | | • | | | | | | | | | | | |
| | GAS MANIFOLD 15 INJ. D:1.32 | 65105037 | NAT | | | | | | | • | | | | | | | • | | 02/08 | | | |
| | GAS MANIFOLD 16 INJ. D:1.32 | 65105997 | NAT | | | | | | | • | | | | | | | • | | 12/10 | | | |
| | GAS MANIFOLD 11 INJ. D:1.32 | 65106302 | NAT | | | | • | | | | | • | | | | | | | 03/08 | | | |
| 0160 | CLIP | 61010050 | | • | • | • | • | • | • | • | • | • | • | • | • | • | • | • | | | | |
| 0200 | GAS SECTION | | | | | | | | | | | | | | | | | | | | | |
| 0201 | GAS VALVE | 65104254 | | • | • | • | • | • | • | • | • | • | • | • | • | • | • | • | | | | |
| 0204 | SPARK GENERATOR | 65104653 | | • | • | • | • | • | • | • | • | • | • | • | • | • | • | • | | | | |
| 0210 | RESTRICTOR D: 6.3 | 60000018 | NAT | | | | • | | | | | | | | • | | | | 02/08 | | | |
| | RESTRICTOR D: 6.3 | 60000018 | NAT | • | | • | | | | • | | • | | | | | | | | | | |
| | RESTRICTOR D: 5.7 | 60000498 | NAT | | | | • | | | | | • | | | | | | | 03/08 | | | |
| | RESTRICTOR D: 6.5 | 60000821 | NAT | | • | | | | | | • | | | | | | | | | | | |
| | RESTRICTOR D: 7 | 65105152 | NAT | | | | | • | | | | | | | | • | | | | | | |
| | RESTRICTOR D: 6.9 | 65105154 | NAT | | | | | | • | | | | | | | | • | | | | | |
| 0214 | PIPE (GAS VALVE/BURNER) | 65104230 | | • | • | • | • | • | • | • | • | • | • | • | • | • | • | • | | | | |
| 0216 | GROMMET | 60000624 | | • | • | • | • | • | • | • | • | • | • | • | • | • | • | • | | | | |
| 0217 | UNION (3/4) | 65104326 | | • | • | • | • | • | • | • | • | • | • | • | • | • | • | • | | | | |
| 0218 | UNION (1/2) | 65104327 | | • | • | • | • | • | • | • | • | • | • | • | • | • | • | • | | | | |
| 0250 | GAS TUBE | 60000720 | | • | • | • | • | • | • | • | • | • | • | • | • | • | • | • | | | | |
| 0251 | EPDM PIPE | 65104296 | | | | | • | • | • | | | | | | • | • | • | | | | | |
| 0270 | GASKET (SPARK GENERATOR) | 574279 | | • | • | • | • | • | • | • | • | • | • | • | • | • | • | • | | | | |
| 0280 | O-RING D: 14-2.00 | 60000903 | NAT | • | • | • | • | • | • | • | • | • | • | • | • | • | • | • | | | | |
| 0281 | O-RING 22,22X2,62 | 65104304 | | • | • | • | • | • | • | • | • | • | • | • | • | • | • | • | | | | |
| 0283 | O-RING 17,17X1,78 | 65104303 | | • | • | • | • | • | • | • | • | • | • | • | • | • | • | • | | | | |

300
400

URBIA - SERELIA

Domestic Gas Boilers

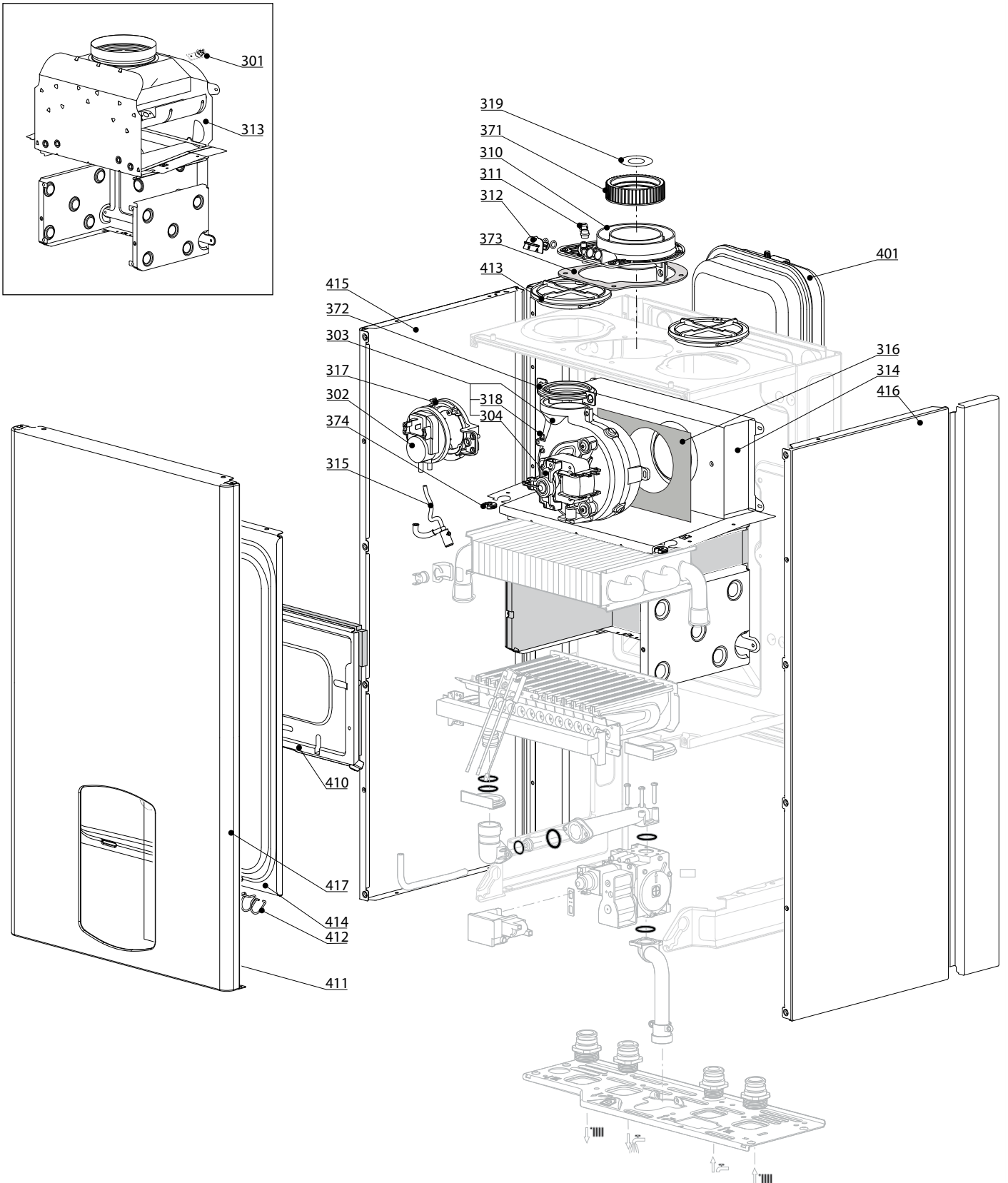

| ☉⇒ | Description | Manf. Pt. N | Type | <div style="display: flex; justify-content: space-between; font-size: small;"> URBIA 23 CF URBIA 30 CF URBIA 24 VMC URBIA 23 FF URBIA 30 FF URBIA 35 FF SERELIA 23 CF SERELIA 30 CF SERELIA 24 VMC SERELIA 23 FF SERELIA 30 FF SERELIA 35 FF </div> | | | | | | | | | | | | | | | | | | 31 |
|-------------|----------------------------------|-------------|------|---|---|---|---|---|---|---|---|---|----|----|----|----|----|----|-------|----|----|----|
| | | | | 1 | 2 | 3 | 4 | 5 | 6 | 7 | 8 | 9 | 10 | 11 | 12 | 13 | 14 | 15 | 16 | 17 | 18 | |
| 0300 | FAN ASSEMBLY | | | | | | | | | | | | | | | | | | | | | |
| 0301 | OVERHEAT THERMOSTAT 49C | 61310767 | | | | • | | | | | • | | | | | | | | | | | |
| | THERMOSTAT 75-65°C | 999539 | | • | • | | | | | • | • | | | | | | | | | | | |
| 0302 | AIR PRESSURE SWITCH 50 Pa | 65104671-01 | | | | | • | | | | | • | | | | | | | | | | |
| | AIR PRESSURE SWITCH 74 Pa | 65104672-01 | | | | | | • | • | | | | • | • | | | | | | | | |
| 0303 | FAN | 65104231 | | | | | | • | | | | | • | | | | | | | | | |
| | FAN | 65104255 | | | | | | • | | | | | • | | | | | | | | | |
| | FAN | 65105042 | | | | | | | • | | | | | | • | | | | | | | |
| 0304 | HALL SENSOR 28/30/35 FF | 65108255 | | | | | | • | • | | | | | • | • | | | | | | | |
| | HALL SENSOR 15/24/25 FF | 65108301 | | | | | | • | | | | | | • | | | | | | | | |
| 0310 | FLUE (EXHAUST MANIFOLD / HEADER) | 65105393 | | | | | • | • | • | | | | • | • | • | | | | | | | |
| 0311 | AIR INTAKE COVER | 573329 | | | | | • | • | • | | | | • | • | • | | | | | | | |
| 0312 | FLUE INTAKE PLUG | 65104295 | | | | | • | • | • | | | | • | • | • | | | | | | | |
| 0313 | COMBUSTION CHAMBER 24CF | 65104218 | | • | | • | | | | • | | • | | | | | | | | | | |
| | COMBUSTION CHAMBER 28CF | 65105028 | | | • | | | | | • | | | | | | | | | | | | |
| 0314 | COMBUSTION CHAMBER 24/28 FF | 65104219 | | | | | • | | | | | | • | | | | | | 02/08 | | | |
| | COMBUSTION CHAMBER 24/28 FF | 65104219 | | | | | | • | | | | | | • | | | | | | | | |
| | COMBUSTION CHAMBER 35FF | 65105040 | | | | | | | • | | | | | | • | | | | | | | |
| | COMBUSTION CHAMBER 24/28 FF | 65106295 | | | | | | • | | | | | • | | | | | | 03/08 | | | |
| 0315 | CONDENSATE TRAP | 65104623 | | | | | • | • | • | | | | • | • | • | | | | | | | |
| 0316 | PANEL (INSULATION - FAN) | 65104305 | | | | | • | • | • | | | | • | • | • | | | | | | | |
| 0317 | SUPPORT (AIR PRESSURE SWITCH) | 65104378 | | | | | • | • | • | | | | • | • | • | | | | | | | |
| 0318 | VENTURI 28/30FF | 65106515 | | | | | | • | | | | | | • | | | | | | | | |
| | VENTURI 15/24FF | 65106516 | | | | | | • | | | | | | • | | | | | | | | |
| | VENTURI 32/35FF | 65106517 | | | | | | | • | | | | | | • | | | | | | | |
| 0319 | RESTRICTOR KIT | 60001598 | | | | | • | • | • | | | | • | • | • | | | | | | | |
| 0371 | COLLAR GASKET | 65104258 | | | | | • | • | • | | | | • | • | • | | | | | | | |
| 0372 | FAN GASKET | 65104257 | | | | | • | • | • | | | | • | • | • | | | | | | | |
| 0373 | GASKET | 60000317 | | | | | • | • | • | | | | • | • | • | | | | | | | |
| 0374 | CABLE INLET RUBBER WASHER | 60000716 | | • | • | • | • | • | • | • | • | • | • | • | • | • | • | • | • | | | |
| 0400 | SEALED CASE | | | | | | | | | | | | | | | | | | | | | |
| 0401 | EXPANSION VESSEL 7.5L | 60000823 | | • | • | • | • | • | • | • | • | • | • | • | • | • | • | • | • | | | |
| 0410 | PANEL (COMBUSTION CHAMBER) | 65104240 | | | | | • | | | | | | • | | | | | | 02/08 | | | |
| | PANEL (COMBUSTION CHAMBER) | 65104240 | | • | | • | | | • | | • | | | • | | | | | | | | |
| | PANEL (COMBUSTION CHAMBER) | 65105033 | | | • | | | | | • | | | | | • | | | | | | | |
| | PANEL (COMBUSTION CHAMBER) | 65106296 | | | | | • | | | | | | | • | | | | | 03/08 | | | |
| 0411 | SIGHT GLASS | 65104232 | | | | | • | • | • | | | | • | • | • | | | | | | | |
| 0412 | SPRING FRONT PANEL (KIT) | 65104298 | | | | | • | • | • | | | | • | • | • | | | | | | | |
| 0413 | AIR RETURN COVER | 65104249 | | | | | • | • | • | | | | • | • | • | | | | | | | |
| 0414 | PANEL (FRONT - SEALED CHAMBER) | 65105679 | | | | | • | • | • | | | | • | • | • | | | | | | | |
| 0415 | CASE PANEL (L.H. SIDE) | 65105676 | | • | • | • | • | • | • | • | • | • | • | • | • | • | • | • | • | | | |
| 0416 | CASE PANEL (R.H. SIDE) | 65105677 | | • | • | • | • | • | • | • | • | • | • | • | • | • | • | • | • | | | |
| 0417 | CASE PANEL (FRONT) | 60000719 | | • | • | • | • | • | • | • | • | • | • | • | • | • | • | • | • | | | |
| 0420 | EXPANSION VESSEL SUPPORT | 65104696 | | • | • | • | • | • | • | • | • | • | • | • | • | • | • | • | • | | | |

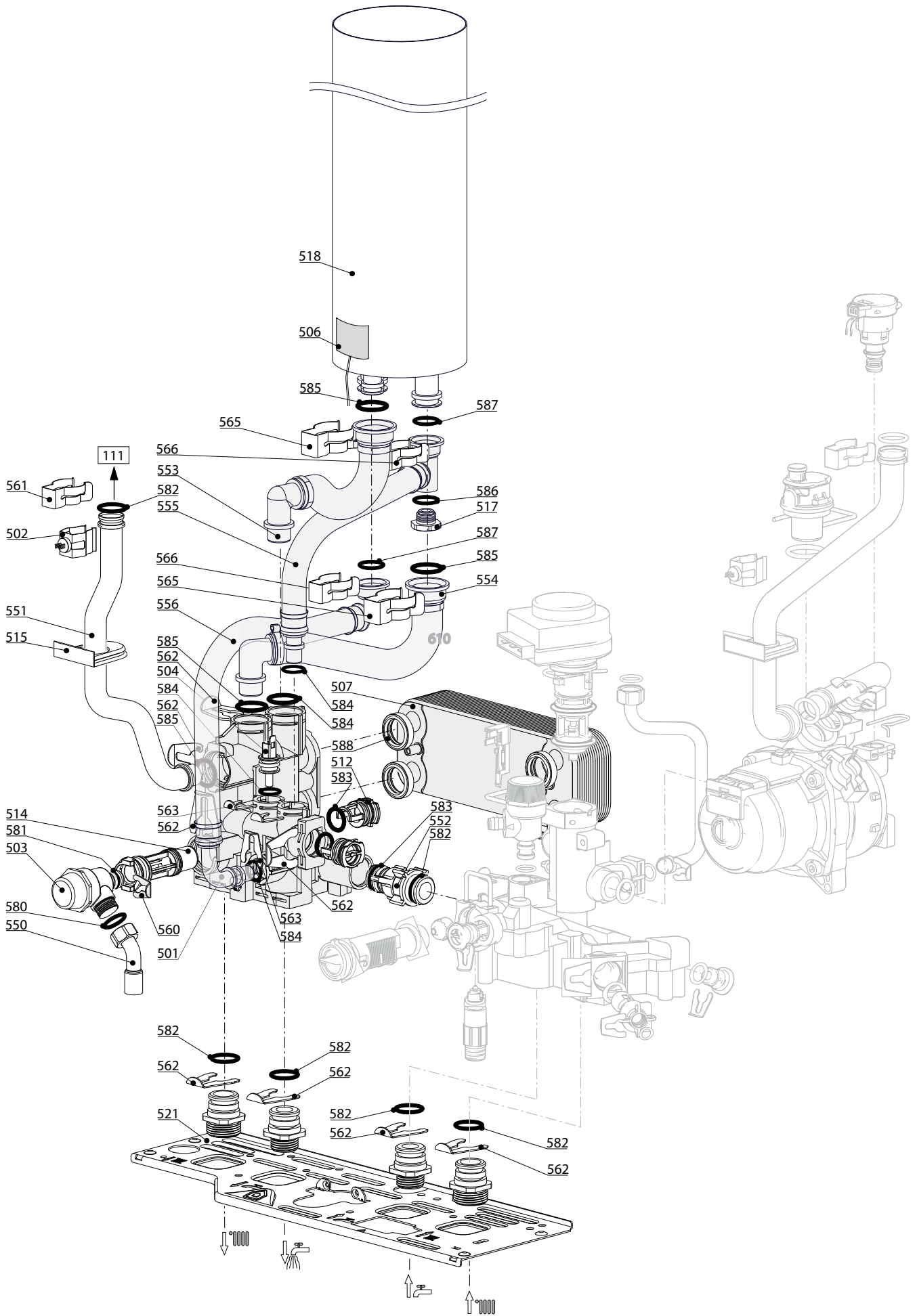

| ☉⇒ | Description | Manf. Pt. N | Type | <div style="display: flex; justify-content: space-between; font-size: small;"> URBIA 23 CFURBIA 30 CFURBIA 24 VMCURBIA 23 FFURBIA 30 FFSERELIA 23 CFSERELIA 30 CFSERELIA 24 VMCSERELIA 23 FFSERELIA 30 FF </div> | | | | | | | | | | | | | | | | | | 31 |
|-------------|---------------------------------|-------------|------|--|---|---|---|---|---|---|---|---|----|----|----|----|----|----|----|----|----|----|
| | | | | 1 | 2 | 3 | 4 | 5 | 6 | 7 | 8 | 9 | 10 | 11 | 12 | 13 | 14 | 15 | 16 | 17 | 18 | |
| 0500 | FLOW GROUP | | | | | | | | | | | | | | | | | | | | | |
| 0501 | FLOW GROUP | 60000873 | | • | • | • | • | • | • | • | • | • | • | • | • | • | • | • | • | | | |
| 0502 | TEMPERATURE PROBE + CLIP | 990686 | | • | • | • | • | • | • | • | • | • | • | • | • | • | • | • | • | | | |
| 0503 | PRESSURE RELIEF VALVE 3 BAR | 61312668 | | • | • | • | • | • | • | • | • | • | • | • | • | • | • | • | • | | | |
| 0504 | NTC PROBE | 65104338 | | • | • | • | • | • | • | • | • | • | • | • | • | • | • | • | • | | | |
| 0506 | NTC PROBE | 60000822 | | • | • | • | • | • | • | • | • | • | • | • | • | • | • | • | • | | | |
| 0507 | WATER / WATER HEAT EXCHANGER 16 | 65104333 | | • | • | • | • | • | • | • | • | • | • | • | • | • | • | • | • | | | |
| 0512 | PLUG | 65104445 | | • | • | • | • | • | • | • | • | • | • | • | • | • | • | • | • | | | |
| 0514 | BY-PASS | 65104336 | | • | • | • | • | • | • | • | • | • | • | • | • | • | • | • | • | | | |
| 0515 | GROMMET | 60000808 | | • | • | • | • | • | • | • | • | • | • | • | • | • | • | • | • | | | |
| 0517 | PLUG 3/4» | 60000996 | | • | • | • | • | • | • | • | • | • | • | • | • | • | • | • | • | | | |
| 0518 | CYLINDER 4L | 60000831 | | • | • | • | • | • | • | • | • | • | • | • | • | • | • | • | • | | | |
| | CYLINDER 15L | 60000832 | | | | | | | • | • | • | • | • | • | • | • | • | • | | | | |
| 0521 | HYDRAULIC GROUP SUPPORT | 60001375 | | • | • | • | • | • | • | • | • | • | • | • | • | • | • | • | • | | | |
| 0550 | PIPE (SAFETY VALVE) | 65104447 | | • | • | • | • | • | • | • | • | • | • | • | • | • | • | • | • | | | |
| 0551 | HEATING FLOW TUBE | 60000722 | | | | | • | | | | | • | | | | | | | | | | |
| | HEATING FLOW TUBE | 60000722 | | • | | • | | • | | • | | • | | | | | | | | | | |
| | HEATING FLOW TUBE | 60000989 | | | • | | | • | | • | | • | | | | | | | | | | |
| | HEATING FLOW TUBE | 60001131 | | | | | • | | | | | • | | | | | | | | | | |
| 0552 | BY-PASS PIPE | 65104340 | | • | • | • | • | • | • | • | • | • | • | • | • | • | • | • | • | | | |
| 0553 | HEATING TUBE | 60000846 | | • | • | • | • | • | • | • | • | • | • | • | • | • | • | • | • | | | |
| | HEATING TUBE | 60000853 | | | | | | | | • | • | • | • | • | • | • | • | • | • | | | |
| 0554 | HEATING TUBE | 60000847 | | • | • | • | • | • | • | • | • | • | • | • | • | • | • | • | • | | | |
| 0555 | INLET PIPE | 60000854 | | • | • | • | • | • | • | • | • | • | • | • | • | • | • | • | • | | | |
| 0556 | PIPE (SECONDARY RETURN) | 60000849 | | • | • | • | • | • | • | • | • | • | • | • | • | • | • | • | • | | | |
| | PIPE (SECONDARY RETURN) | 60000855 | | | | | | | | • | • | • | • | • | • | • | • | • | • | | | |
| 0560 | CLIP D:10 | 65104260 | | • | • | • | • | • | • | • | • | • | • | • | • | • | • | • | • | | | |
| 0561 | CLIP | 61307589 | | • | • | • | • | • | • | • | • | • | • | • | • | • | • | • | • | | | |
| 0562 | CLIP D=18 | 65104259 | | • | • | • | • | • | • | • | • | • | • | • | • | • | • | • | • | | | |
| 0563 | CLIP | 65104339 | | • | • | • | • | • | • | • | • | • | • | • | • | • | • | • | • | | | |
| 0565 | CLIP | 60000309 | | • | • | • | • | • | • | • | • | • | • | • | • | • | • | • | • | | | |
| 0566 | CLIP | 65105109 | | • | • | • | • | • | • | • | • | • | • | • | • | • | • | • | • | | | |
| 0580 | SHEET GASKET D: 13.9-10.4-1.5 | 60061853-02 | | • | • | • | • | • | • | • | • | • | • | • | • | • | • | • | • | | | |
| 0581 | O - RING (15.88X2.62) | 65104337 | | • | • | • | • | • | • | • | • | • | • | • | • | • | • | • | • | | | |
| 0582 | O-RING D: 17.86-2.62 | 61308091 | | • | • | • | • | • | • | • | • | • | • | • | • | • | • | • | • | | | |
| 0583 | O - RING (15.54X2.62) | 65104325 | | • | • | • | • | • | • | • | • | • | • | • | • | • | • | • | • | | | |
| 0584 | O-RING D: 11.91-2.62 | 60000850 | | • | • | • | • | • | • | • | • | • | • | • | • | • | • | • | • | | | |
| 0585 | O-RING 3,53X17,04 | 65104262 | | • | • | • | • | • | • | • | • | • | • | • | • | • | • | • | • | | | |
| 0586 | SHEET GASKET D: 11-5-1.5 | 60061853-07 | | • | • | • | • | • | • | • | • | • | • | • | • | • | • | • | • | | | |
| 0587 | O-RING D: 12.1-2.7 | 60024164-16 | | • | • | • | • | • | • | • | • | • | • | • | • | • | • | • | • | | | |
| 0588 | EXCHANGER GASKET | 65104334 | | • | • | • | • | • | • | • | • | • | • | • | • | • | • | • | • | | | |

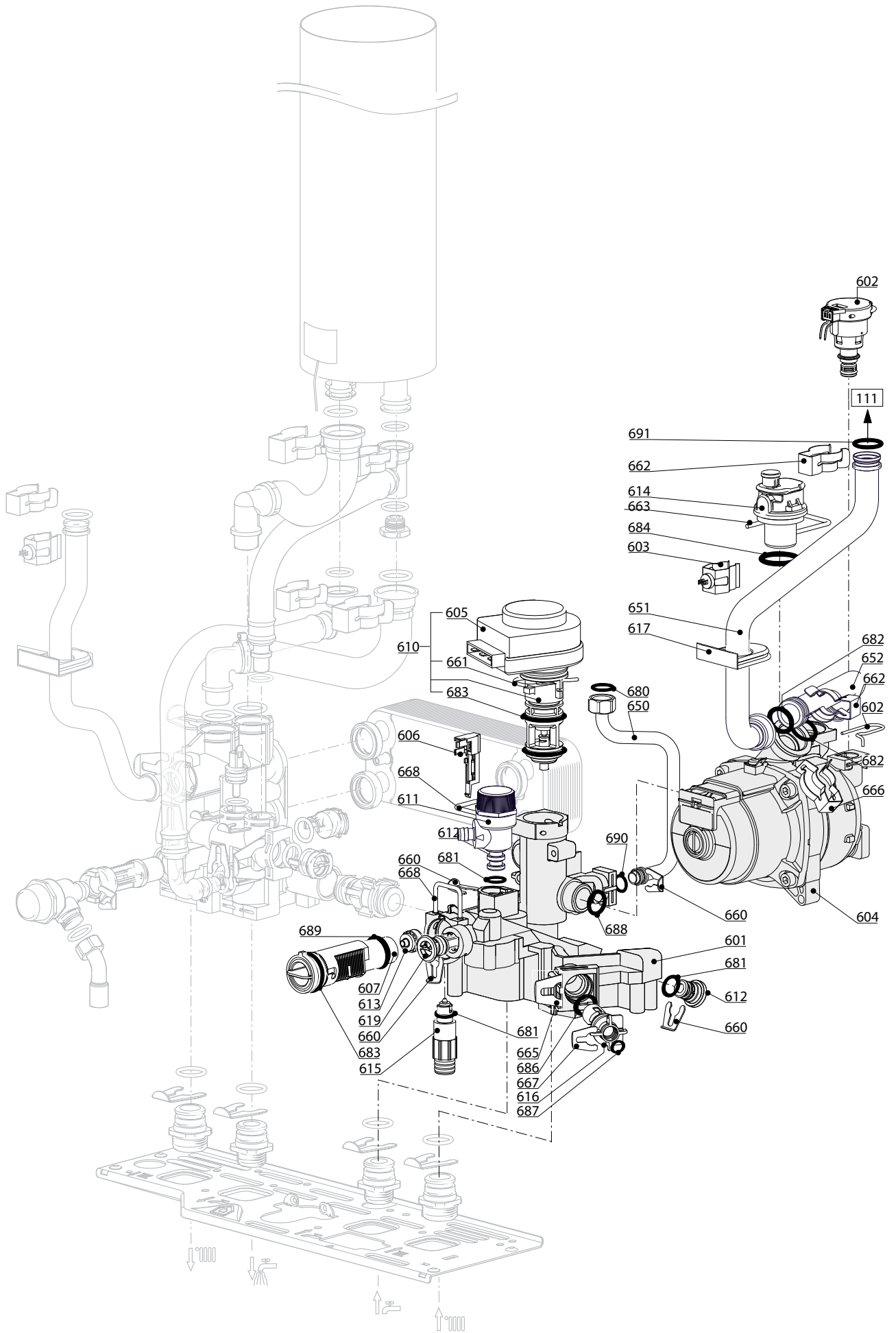

| ☉→ | Description | Manf. Pt. N | Type | <div style="display: flex; justify-content: space-between; font-size: small;"> URBIA 23 CF URBIA 30 CF URBIA 24 VMC URBIA 23 FF URBIA 30 FF SERELIA 23 CF SERELIA 30 CF SERELIA 24 VMC SERELIA 23 FF SERELIA 30 FF </div> | | | | | | | | | | | | | | | | | | 31 |
|-------------|--------------------------------|-------------|------|---|---|---|---|---|---|---|---|---|----|----|----|----|----|----|----|----|----|----|
| | | | | 1 | 2 | 3 | 4 | 5 | 6 | 7 | 8 | 9 | 10 | 11 | 12 | 13 | 14 | 15 | 16 | 17 | 18 | |
| 0600 | RETURN GROUP | | | | | | | | | | | | | | | | | | | | | |
| 0601 | RETURN GROUP | 60000874 | | • | • | • | • | • | • | • | • | • | • | • | • | • | • | • | • | | | |
| 0602 | PROPORTIONAL PRESSURE SWITCH | 65104321 | | • | • | • | • | • | • | • | • | • | • | • | • | • | • | • | • | | | |
| 0603 | TEMPERATURE PROBE + CLIP | 990686 | | • | • | • | • | • | • | • | • | • | • | • | • | • | • | • | • | | | |
| 0604 | PUMP 6M 2V | 60000591 | | • | | | • | • | | • | | • | | • | | | | | | | | |
| | PUMP 5M 2V | 65104319 | | • | • | • | | | • | | • | • | | | | | | | | | | |
| 0605 | MOTOR - THREE-WAY VALVE | 61302483-01 | | • | • | • | • | • | • | • | • | • | • | • | • | • | • | • | • | | | |
| 0606 | SENSOR (REED) | 65104323 | | • | • | • | • | • | • | • | • | • | • | • | • | • | • | • | • | | | |
| 0607 | FLOW METER | 60000870 | | • | • | • | • | • | • | • | • | • | • | • | • | • | • | • | • | | | |
| 0610 | MOTOR + SPRING 3 WAY VALVE KIT | 60001583 | | • | • | • | • | • | • | • | • | • | • | • | • | • | • | • | • | | | |
| 0611 | PRESSURE RELIEF VALVE 7 BARS | 60000171 | | • | • | • | • | • | • | • | • | • | • | • | • | • | • | • | • | | | |
| 0612 | PLUG | 65104377 | | • | • | • | • | • | • | • | • | • | • | • | • | • | • | • | • | | | |
| 0613 | RIDUCTORS (KIT) | 65104318 | | • | • | • | • | • | • | • | • | • | • | • | • | • | • | • | • | | | |
| 0614 | AUTO AIR VENT WITH O-RING | 65104703 | | • | • | • | • | • | • | • | • | • | • | • | • | • | • | • | • | | | |
| 0615 | KIT DRAIN SCREW | 60001385 | | • | • | • | • | • | • | • | • | • | • | • | • | • | • | • | • | | | |
| 0616 | WATER FILTER | 60001372 | | • | • | • | • | • | • | • | • | • | • | • | • | • | • | • | • | | | |
| 0617 | GROMMET | 60000807 | | • | • | • | • | • | • | • | • | • | • | • | • | • | • | • | • | | | |
| 0619 | PLUG | 65104377 | | • | • | • | • | • | • | • | • | • | • | • | • | • | • | • | • | | | |
| 0650 | PIPE (EXPANSION VESSEL) | 60000851 | | • | • | • | • | • | | | | | | | | | | | | | | |
| | PIPE (EXPANSION VESSEL) | 60000856 | | | | | | | • | • | • | • | • | • | • | • | • | • | • | | | |
| 0651 | HEATING RETURN TUBE | 60000723 | | | | | • | | | | | | • | | | | | | | | | |
| | HEATING RETURN TUBE | 60000723 | | • | | • | | • | | • | | • | | • | | | | | | | | |
| | HEATING RETURN TUBE | 60001132 | | | | | • | | | | | | • | | | | | | | | | |
| | PIPE (C.H. RETURN) | 65104265 | | | • | | | | • | | | | | • | | | | | | | | |
| 0652 | HEATING RETURN TUBE | 60000724 | | • | | • | • | • | • | • | • | • | • | • | • | • | • | • | • | | | |
| | HEATING RETURN TUBE | 60000990 | | | • | | | | • | | | | | • | | | | | | | | |
| 0660 | CLIP D:10 | 65104260 | | • | • | • | • | • | • | • | • | • | • | • | • | • | • | • | • | | | |
| 0661 | CLIP | 65104332 | | • | • | • | • | • | • | • | • | • | • | • | • | • | • | • | • | | | |
| 0662 | CLIP | 61307589 | | • | • | • | • | • | • | • | • | • | • | • | • | • | • | • | • | | | |
| 0663 | U-CLIP | 65104704 | | • | • | • | • | • | • | • | • | • | • | • | • | • | • | • | • | | | |
| 0664 | CLIP | 65104322 | | • | • | • | • | • | • | • | • | • | • | • | • | • | • | • | • | | | |
| 0665 | CLIP | 65104331 | | • | • | • | • | • | • | • | • | • | • | • | • | • | • | • | • | | | |
| 0666 | CLIP | 60000309 | | • | • | • | • | • | • | • | • | • | • | • | • | • | • | • | • | | | |
| 0667 | CLIP | 65100680 | | • | • | • | • | • | • | • | • | • | • | • | • | • | • | • | • | | | |
| 0668 | CLIP | 65104316 | | • | • | • | • | • | • | • | • | • | • | • | • | • | • | • | • | | | |
| 0680 | GASKET 3/8 | 573521 | | • | • | • | • | • | • | • | • | • | • | • | • | • | • | • | • | | | |
| 0681 | O - RING (9.19X2.62) | 65104313 | | • | • | • | • | • | • | • | • | • | • | • | • | • | • | • | • | | | |
| 0682 | O-RING 3,53X17,04 | 65104262 | | • | • | • | • | • | • | • | • | • | • | • | • | • | • | • | • | | | |
| 0683 | O - RING (23.47X2.62) | 65104315 | | • | • | • | • | • | • | • | • | • | • | • | • | • | • | • | • | | | |
| 0684 | O-RING | 65104705 | | • | • | • | • | • | • | • | • | • | • | • | • | • | • | • | • | | | |
| 0686 | O - RING (15.54X2.62) | 65104325 | | • | • | • | • | • | • | • | • | • | • | • | • | • | • | • | • | | | |
| 0687 | O RING D: 5.7-1.9 | 61009834-10 | | • | • | • | • | • | • | • | • | • | • | • | • | • | • | • | • | | | |
| 0688 | O - RING (21.89X2.62) | 65104320 | | • | • | • | • | • | • | • | • | • | • | • | • | • | • | • | • | | | |
| 0689 | O-RING 17,17X1,78 | 65104303 | | • | • | • | • | • | • | • | • | • | • | • | • | • | • | • | • | | | |
| 0690 | O-RING D: 8.9-2.7 | 61009834-14 | | • | • | • | • | • | • | • | • | • | • | • | • | • | • | • | • | | | |
| 0691 | O-RING D: 17.86-2.62 | 61308091 | | • | • | • | • | • | • | • | • | • | • | • | • | • | • | • | • | | | |

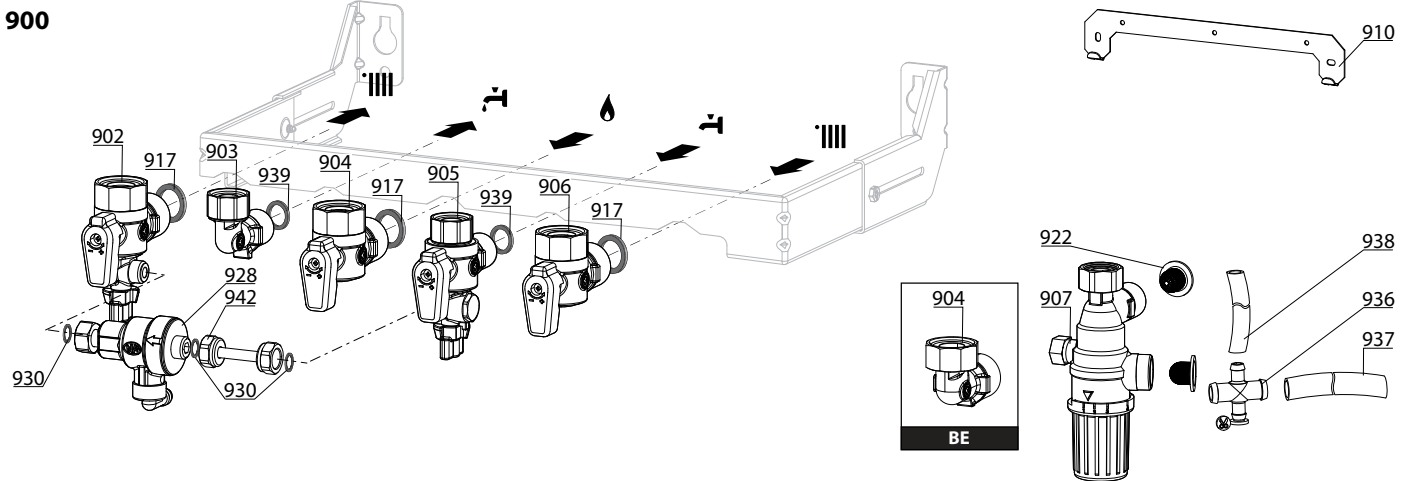
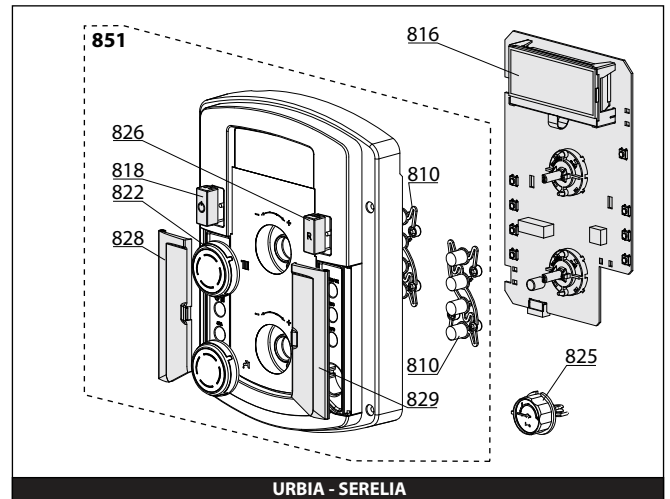
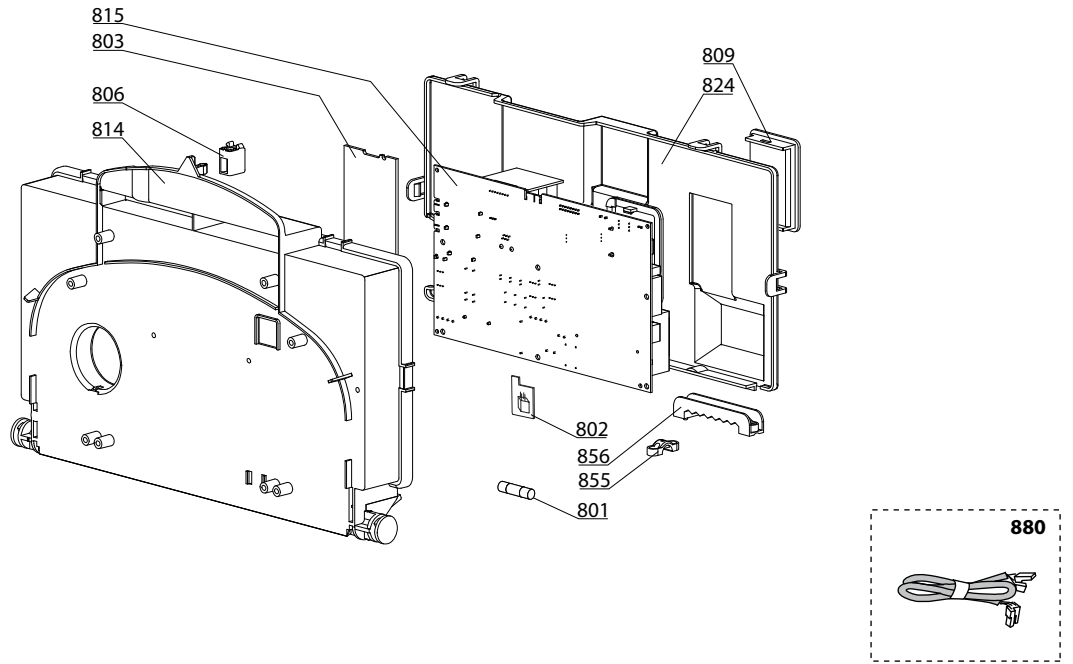

5000

5001
 Transf. gaz > B/P
 Conv. gas > LPG
 Transf. gas > GPL
 Transf. gas > B/P
 Umrustsatz > B/P

5002
 Transf. gaz > Nat
 Conv. gas > Nat
 Transf. gas > Met
 Transf. gas > Met
 Umrustsatz > Nat

5020
 Options
 Accessories
 Opzioni
 Accessorio
 Option

| ☉➔ | Description | Manf. Pt. N | Type | <div style="display: flex; justify-content: space-between; font-size: small;"> URBIA 23 CF URBIA 30 CF URBIA 24 VMC URBIA 23 FF URBIA 30 FF SERELIA 23 FF SERELIA 23 CF SERELIA 30 CF SERELIA 24 VMC SERELIA 23 FF SERELIA 30 FF </div> | | | | | | | | | | | | | | | | | | 31 |
|-------------|--|-------------|--------|--|---|---|---|---|---|---|---|---|----|----|----|----|----|----|----|----|----|----|
| | | | | 1 | 2 | 3 | 4 | 5 | 6 | 7 | 8 | 9 | 10 | 11 | 12 | 13 | 14 | 15 | 16 | 17 | 18 | |
| 0800 | ELECTRICAL BOX | | | | | | | | | | | | | | | | | | | | | |
| 0801 | FUSE 250V 2A - TEMPORIZED | 61003456 | | • | • | • | • | • | • | • | • | • | • | • | • | • | • | • | • | | | |
| 0802 | MODULE KIT (EEPROM) | 65105148 | | • | • | • | • | • | • | • | • | • | • | • | • | • | • | • | • | | | |
| 0803 | P.C.B (CLIP-IN) E-BUS | 65109108 | | • | • | • | • | • | • | • | • | • | • | • | • | • | • | • | • | | | |
| 0806 | PUSH | 65104228 | | • | • | • | • | • | • | • | • | • | • | • | • | • | • | • | • | | | |
| 0809 | INSPECTION COVER | 65104294 | | • | • | • | • | • | • | • | • | • | • | • | • | • | • | • | • | | | |
| 0810 | PUSH BUTTON | 60000978 | | • | • | • | • | • | • | • | • | • | • | • | • | • | • | • | • | | | |
| 0814 | CONTROL PANEL | 65104300 | | • | • | • | • | • | • | • | • | • | • | • | • | • | • | • | • | | | |
| 0815 | P.C.B. (MAIN) | 65109313-02 | | • | • | • | • | • | • | • | • | • | • | • | • | • | • | • | • | | | |
| 0816 | PRINTED CIRCUIT BOARD (DISPLAY) | 60000760-01 | | • | • | • | • | • | • | • | • | • | • | • | • | • | • | • | • | | | |
| 0818 | PUSH BUTTON ON/OFF | 60000809 | | • | • | • | • | • | • | • | • | • | • | • | • | • | • | • | • | | | |
| 0822 | KNOB | 60000762 | | • | • | • | • | • | • | • | • | • | • | • | • | • | • | • | • | | | |
| 0824 | CONTROL PANEL COVER (REAR) | 65104293 | | • | • | • | • | • | • | • | • | • | • | • | • | • | • | • | • | | | |
| 0825 | PRESSURE GAUGE | 60000725 | | • | • | • | • | • | • | • | • | • | • | • | • | • | • | • | • | | | |
| 0826 | BUTTON (RESET) | 60000806 | | • | • | • | • | • | • | • | • | • | • | • | • | • | • | • | • | | | |
| 0828 | LEFT HAND DOOR | 60000761 | | • | • | • | • | • | • | • | • | • | • | • | • | • | • | • | • | | | |
| 0829 | RIGHT HAND DOOR | 60000759 | | • | • | • | • | • | • | • | • | • | • | • | • | • | • | • | • | | | |
| 0851 | FRONT CONTROL PANEL COMPLETE | 60000805 | | • | • | • | • | • | • | • | • | • | • | • | • | • | • | • | • | | | |
| 0855 | CABLE CLAMP | 571562 | | • | • | • | • | • | • | • | • | • | • | • | • | • | • | • | • | | | |
| 0856 | CABLE CLAMP | 65103377 | | • | • | • | • | • | • | • | • | • | • | • | • | • | • | • | • | | | |
| 0880 | EARTH WIRE | 65104286 | | • | • | • | • | • | • | • | • | • | • | • | • | • | • | • | • | | | |
| | DISPLAY WIRING | 60000746 | / CN02 | • | • | • | • | • | • | • | • | • | • | • | • | • | • | • | • | | | |
| | NTC - PRES. SENSOR - GAS VALVE CABLE | 60000840 | / CN04 | • | • | • | • | • | • | • | • | • | • | • | • | • | • | • | • | | | |
| | IONIZATION ELECTRODE CABLE | 65104518 | / CN05 | • | • | • | • | • | • | • | • | • | • | • | • | • | • | • | • | | | |
| | SHUNT CABLE | 60000839 | / CN07 | | | • | | | | | • | | | | | | | | | | | |
| | TACHOMETER FAN CABLE | 65104709 | / CN07 | | | | • | • | • | | | | • | • | • | | | | | | | |
| | THREE WAY VALVE CABLE | 65104523 | / CN09 | • | • | • | • | • | • | • | • | • | • | • | • | • | • | • | • | | | |
| | PUMP 2V CABLE 5M | 65104520 | / CN10 | • | • | • | • | • | • | • | • | • | • | • | • | • | • | • | • | | | |
| | FAN CABLE | 65107270 | / CN10 | | | | • | • | • | | | | • | • | • | | | | | | | |
| | CLIP-IN E-BUS WIRING | 65105169 | / CN11 | • | • | • | • | • | • | • | • | • | • | • | • | • | • | • | • | | | |
| | FLOW METER CABLE | 60000813 | / CN14 | • | • | • | • | • | • | • | • | • | • | • | • | • | • | • | • | | | |
| | FEEDER 240V | 60000993 | / CN20 | • | • | • | • | • | • | • | • | • | • | • | • | • | • | • | • | | | |
| | NTC - OVERHEAT THER. - PRES SWITCH CABLE | 60000814 | / CN22 | | | | • | • | • | | | | • | • | • | | | | | | | |
| | NTC PROBE - OVERHEAT THERMOSTAT CABLE | 60000838 | / CN22 | | | | • | | | | | | • | | | | | | | | | |
| | ROOM THERMOSTAT CABLE | 60000988 | / CN25 | • | • | • | • | • | • | • | • | • | • | • | • | • | • | • | • | | | |
| | NTC PROBE - OVERHEAT THERMOSTAT CABLE | 65104708 | / CN22 | • | • | | | | | • | • | | | | | | | | | | | |
| 0900 | JIG PLATE & PIPE FITTING | | | | | | | | | | | | | | | | | | | | | |
| 0902 | WATER FLOW SERVICE TAP | 60000886 | | • | • | • | • | • | • | • | • | • | • | • | • | • | • | • | • | | | |
| 0903 | HOT WATER CONNECTION | 60000891 | | • | • | • | • | • | • | • | • | • | • | • | • | • | • | • | • | | | |
| 0904 | GAS SERVICE TAP | 60000898 | | • | • | • | • | • | • | • | • | • | • | • | • | • | • | • | • | | | |
| | UNION | 65105631 | | • | • | • | • | • | • | • | • | • | • | • | • | • | • | • | • | | | |
| 0905 | COLD WATER TAP | 60000894 | | • | • | • | • | • | • | • | • | • | • | • | • | • | • | • | • | | | |
| 0906 | WATER FLOW & RETURN SERVI. TAP | 60000885 | | • | • | • | • | • | • | • | • | • | • | • | • | • | • | • | • | | | |
| 0907 | THERMOSTATIC MIXING VALVE | 60001081 | | • | • | • | • | • | • | • | • | • | • | • | • | • | • | • | • | | | |
| 0910 | WALL HOOK | 60001077 | | • | • | • | • | • | • | • | • | • | • | • | • | • | • | • | • | | | |
| 0917 | SHEET GASKET D: 24-17-1.5 | 60061855-19 | | • | • | • | • | • | • | • | • | • | • | • | • | • | • | • | • | | | |
| 0922 | FILTER | 60001087 | | • | • | • | • | • | • | • | • | • | • | • | • | • | • | • | • | | | |
| 0928 | DISCONNECTOR | 60000881 | | • | • | • | • | • | • | • | • | • | • | • | • | • | • | • | • | | | |
| 0930 | SHEET GASKET D: 11-5-1.5 | 60061853-07 | | • | • | • | • | • | • | • | • | • | • | • | • | • | • | • | • | | | |
| 0936 | UNION | 60000879 | | • | • | • | • | • | • | • | • | • | • | • | • | • | • | • | • | | | |
| 0937 | TUBE PVC D: 13x17 L: 1M | 60081266-02 | | • | • | • | • | • | • | • | • | • | • | • | • | • | • | • | • | | | |
| 0938 | TUBE PVC D: 9x12 L: 1M | 60081266 | | • | • | • | • | • | • | • | • | • | • | • | • | • | • | • | • | | | |
| 0939 | SHEET GASKET D: 16.5-11-1.5 | 60061854-14 | | • | • | • | • | • | • | • | • | • | • | • | • | • | • | • | • | | | |
| 0942 | FILLER NECK | 60001078 | | • | • | • | • | • | • | • | • | • | • | • | • | • | • | • | • | | | |
| 5000 | ACCESSORIES | | | | | | | | | | | | | | | | | | | | | |
| 5001 | BURNER JET FULL KIT (LPG) | 65104582 | | | | | | • | | | | | | | | | | • | | | | |
| | BURNER JET FULL KIT (LPG) | 65105166 | | | | | | | • | | | | | | | | | | • | | | |
| | BURNER JET FULL KIT (LPG) | 65106690 | | • | | | • | | • | | | | | | | | | | • | | | |
| | BURNER JET FULL KIT (LPG) | 65106695 | | | • | | | | | • | | | | | | | | | | | | |
| 5002 | BURNER JET FULL KIT (NG) FR | 65104585 | | | | | | • | | | | | | | | | | | • | | | |
| | BURNER JET FULL KIT (NG) | 65105178 | | | | | | | • | | | | | | | | | | • | | | |
| | BURNER JET FULL KIT | 65106513 | | | | • | | | | • | | | | | | | | | | | | |
| | BURNER JET FULL KIT (NG) FR | 65106692 | | • | | | • | | | • | | | | | | | | | • | | | |
| 5020 | ROD PLATE | 60000727 | | • | • | • | • | • | • | • | • | • | • | • | • | • | • | • | • | | | |

LIST OF THE ABBREVIATIONS

| | |
|-------------|--|
| HW | : Hot water. |
| CW | : Cold water. |
| C | : Ceramic resistance (normal heating). |
| Ca | : Ceramic resistance (accelerated heating) |
| TP | : Immersion heater. |
| 1F | : With fittings. |
| 2F | : Without fittings. |
| 3F | : With fittings and another outlet connection. |
| AMI | : With mixing valve. |
| SMI | : Without mixing valve. |
| PUISS | : Power of th appliance. |
| PN | : Appliance with normal pression. |
| LP | : Appliance with low pression. |
| PV | : Appliance with variable power. |
| PF | : Appliance with fixed power. |

IDENTIFICATION PLATE

SERIAL NUMBER

| | | |
|-----------------------------|---------------------------|-----------------------------------|
| 10 Characters : | 04 05 125 011 | |
| | | Sequential number |
| | | Manufacturing day |
| | | Year of manufacture |
| 11 Characters : | 1 95 065004 - 31 | |
| Month of manufacture : | | Technical number of the appliance |
| from 1 to 9 → Jan. to Sep., | | Sequential number |
| O → Oct., N → Nov., | | Year of manufacture |
| D → Dec. | | |
| 19 Characters : | 08 05 0013199 900640031 | |
| Year of manufacture | | Product reference |
| Month of manufacture | | Sequential number |
| 20 Characters : | 3675007 XX 2 07 070 00315 | |
| Product reference | | Sequential number |
| Millenium of manufacture | | Manufacturing day |
| | | Year of manufacture |
| 21 Characters : | 3675007 XX 07 070 0000315 | |
| Product reference | | Sequential number |
| Year of manufacture | | Manufacturing day |

The indications mentioned on the prices, commercial or technical literature and the scheme are written for your guidance and are available at a given time. The CONSTRUCTOR retains the power to modify the presentation, the form, the size, the conception or the material of the products.