

SPARE PARTS EXPLODED VIEW  
INSTANTANEOUS GAS WATER HEATERS  
Model  
**FLUENDO E/T**

R8203043-06 - 21/12/2018

1	3675042	FLUENDO 11 CF E/T NAT FR	10-2006	12-2014
2	3675043	FLUENDO 14 CF E/T NAT FR	03-2007	12-2014
Col	Reference	Model type	Begin	End

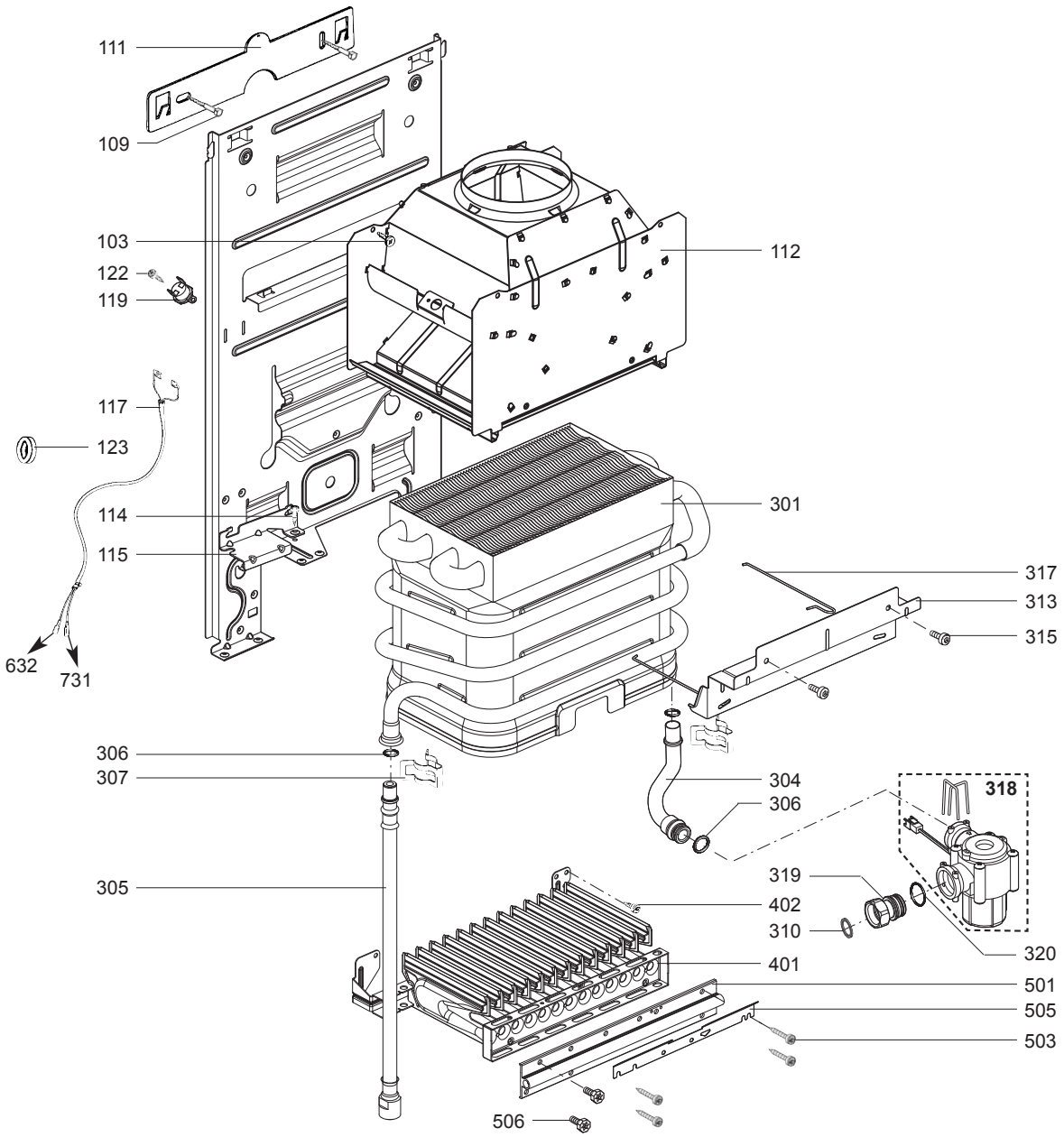



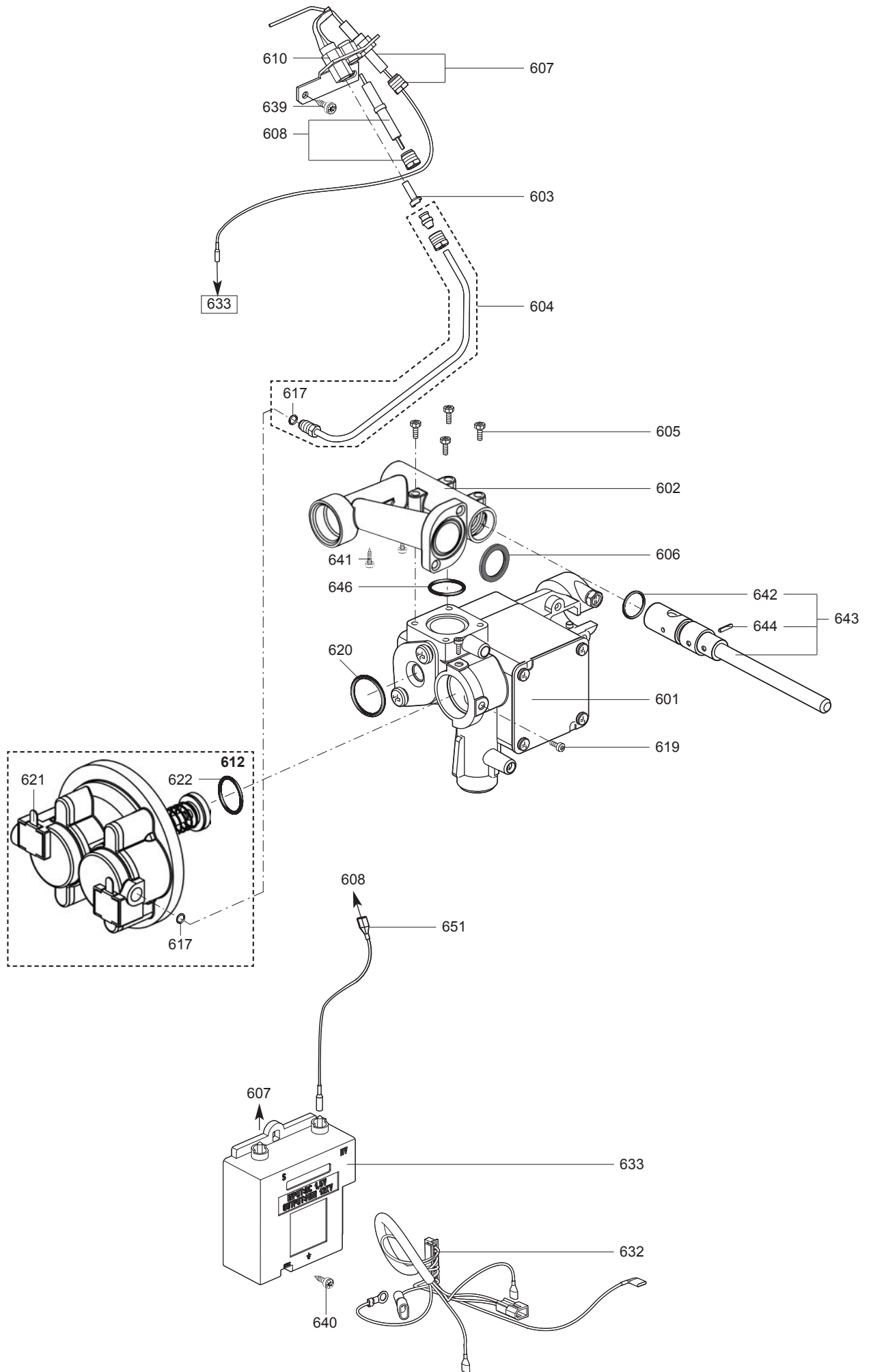



700

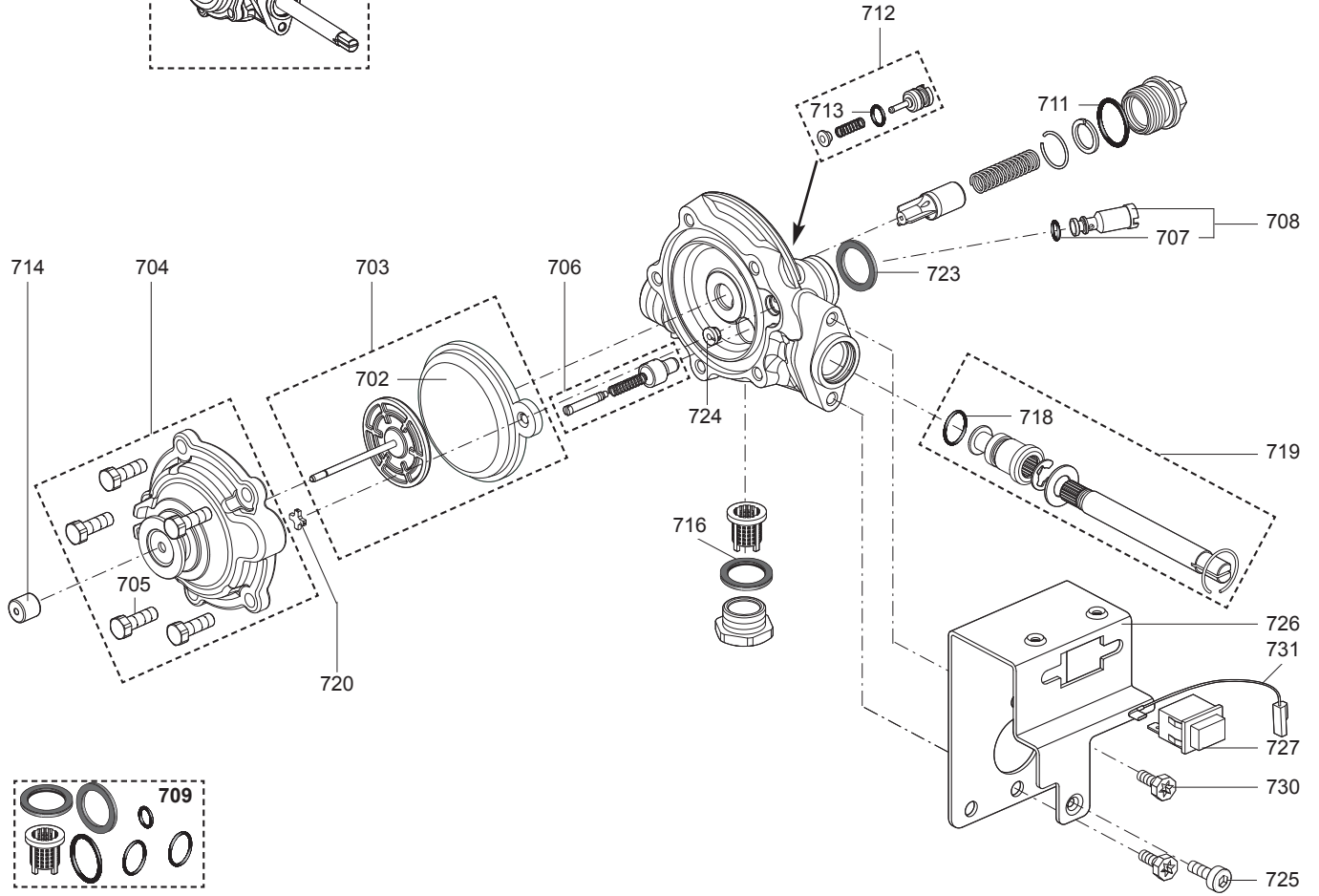
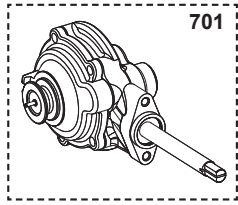

800

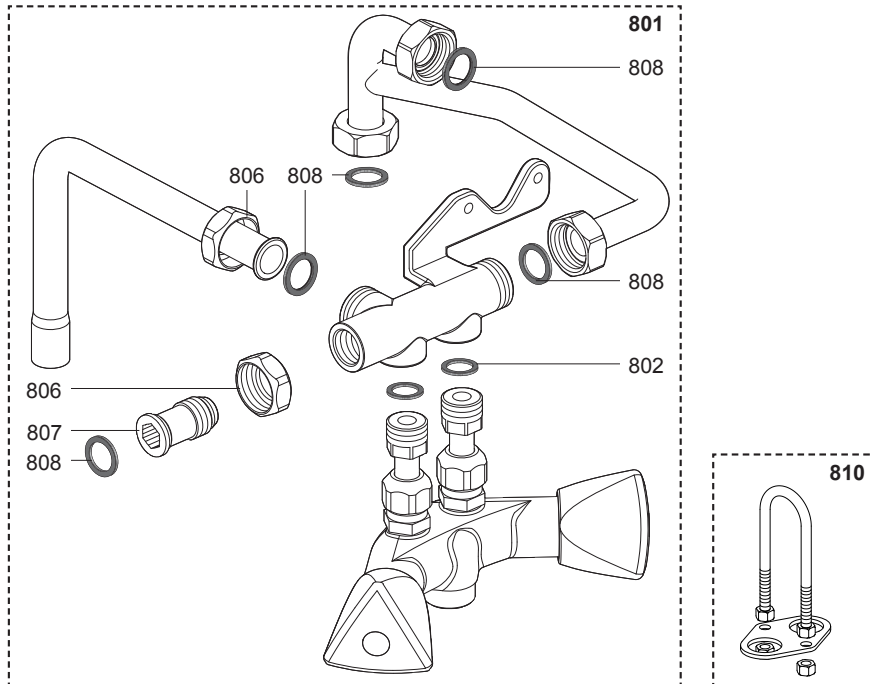



900

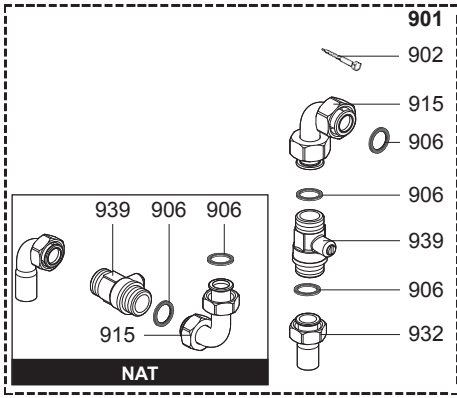

1000

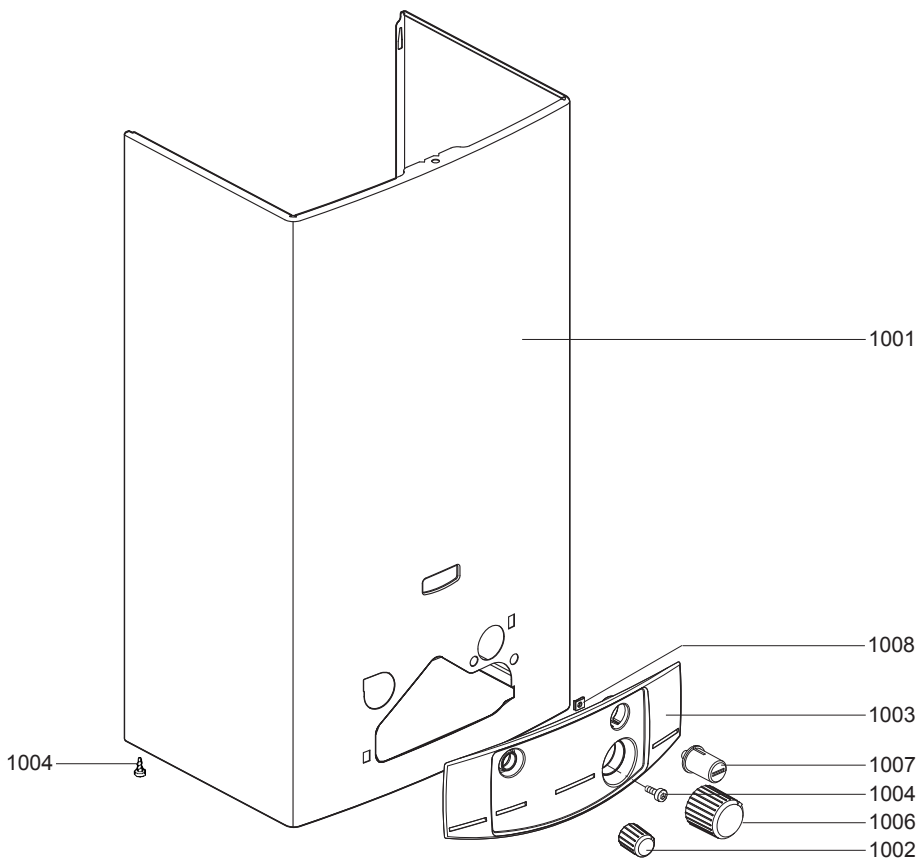

5000

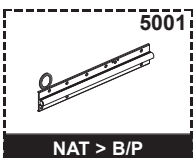





## LIST OF THE ABBREVIATIONS

HW .....	: Hot water.
CW .....	: Cold water.
C .....	: Ceramic resistance (normal heating).
Ca .....	: Ceramic resistance (accelerated heating)
TP .....	: Immersion heater.
1F .....	: With fittings.
2F .....	: Without fittings.
3F .....	: With fittings and another outlet connection.
AMI .....	: With mixing valve.
SMI .....	: Without mixing valve.
PUISS .....	: Power of th appliance.
PN .....	: Appliance with normal pression.
LP .....	: Appliance with low pression.
PV .....	: Appliance with variable power.
PF .....	: Appliance with fixed power.

## IDENTIFICATION PLATE

### SERIAL NUMBER

<b>10 Characters :</b>	04 05 125 011	Sequential number Manufacturing day Year of manufacture
<b>11 Characters :</b>	1 95 065004 - 31	Technical number of the appliance Sequential number Year of manufacture
Month of manufacture : from 1 to 9 → Jan. to Sep., O → Oct., N → Nov., D → Dec.		
<b>19 Characters :</b>	08 05 0013199 900640031	Product reference Sequential number
Year of manufacture Month of manufacture		
<b>20 Characters :</b>	3675007 XX 2 07 070 00315	Sequential number Manufacturing day Year of manufacture
Product reference Millenium of manufacture		
<b>21 Characters :</b>	3675007 XX 07 070 0000315	Sequential number Manufacturing day
Product reference Year of manufacture		