

# SPARE PARTS EXPLODED VIEW GAS WALL BOILERS

Model

## **INOA - TALIA**

R8203103-11 - 14/03/2012

1	3650193	INOA 25 CF N FR-BE	07/07	
1	3650312	INOA S 25 CF N FR	11/08	
1	3650194	INOA 25 CF B/P FR	07/07	
1	3650258	INOA 25 CF GPO FR	12/07	
2	3650198	INOA 30 CF N FR	07/07	
3	3650195	INOA 24 VMC N FR	07/07	
3	3650260	INOA 24 VMC GPO FR	12/07	
4	3650196	INOA 25 FF N FR-BE	07/07	
4	3650197	INOA 25 FF B/P FR	07/07	
4	3650259	INOA 25 FF GPO FR	12/07	
5	3650200	INOA 30 FF N FR-BE	08/07	
6	3650177	TALIA 25 CF N BE	09/07	
7	3650179	TALIA 30 CF N BE	11/07	
8	3650178	TALIA 25 FF N BE	08/07	
9	3650180	TALIA 30 FF N BE	11/07	
10	3650276	TALIA SYSTEM 15 CF N FR		
11	3650236	TALIA SYSTEM 25 CF N FR	10/07	01/10
11	3310101	TALIA SYSTEM 25 CF N FR	02/10	
12	3650277	TALIA SYSTEM 15 VMC N FR		
13	3650237	TALIA SYSTEM 24 VMC N FR	10/07	01/10
13	3310100	TALIA SYSTEM 24 VMC N FR	02/10	
14	3650238	TALIA SYSTEM 25 FF N FR	09/07	07/10
14	3310097	TALIA SYSTEM 25 FF N FR	08/10	
15	3650239	TALIA SYSTEM 30 FF N FR-BE	10/07	05/10
15	3310116	TALIA SYSTEM 30 FF N FR-BE	06/10	

Col	Reference	Model type	Begin	End
-----	-----------	------------	-------	-----

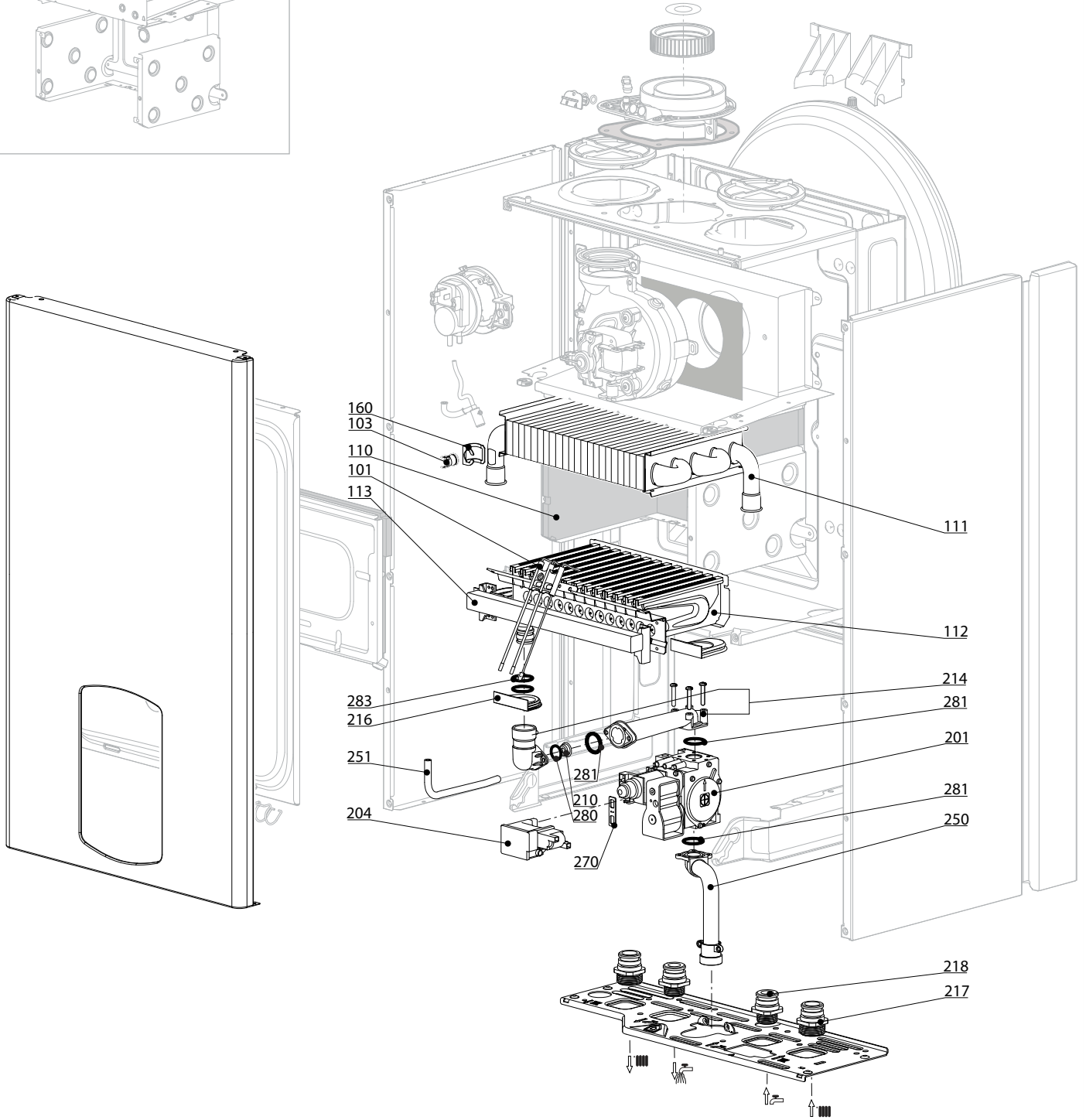
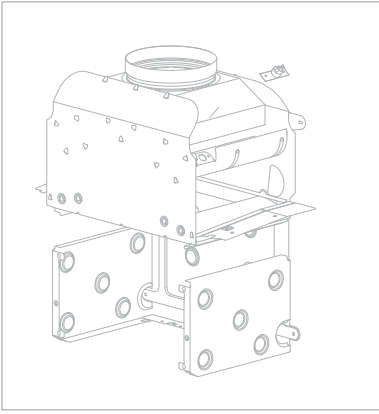

☉	Description	Manf. Pt. N	Type	<div style="display: flex; justify-content: space-between; font-size: 8px; text-align: center;"> <span>INOA 25 CF</span><span>INOA 30 CF</span><span>INOA 24 VMC</span><span>INOA 25 FF</span><span>INOA 30 FF</span><span>TALIA 23 CF</span><span>TALIA 30 CF</span><span>TALIA 23 FF</span><span>TALIA 30 FF</span><span>TALIA SY STEM 15 CF</span><span>TALIA SY STEM 23 CF</span><span>TALIA SY STEM 15 VMC</span><span>TALIA SY STEM 24 VMC</span><span>TALIA SY STEM 23 FF</span> </div>															
				1	2	3	4	5	6	7	8	9	10	11	12	13	14		15
<b>0100</b>	<b>BURNER ASSEMBLY</b>																		
0101	ELECTRODE (IGNITION/DETECTION)	65104549		•	•	•	•	•	•	•	•	•	•	•	•				
0103	THERMOSTAT 102°	65104500		•	•	•	•	•	•	•	•	•	•	•	•				
0110	PANELS (KIT)	65104695				•			•					•					02/08
	PANELS (KIT)	65104695		•	•		•	•		•	•	•	•	•	•				
	PANELS (KIT)	65105029			•			•											
	PANELS (KIT)	65106298				•			•					•					03/08
0111	MAIN EXCHANGER	65104246				•			•					•					02/08
	MAIN EXCHANGER	65104246					•			•					•				
	MAIN EXCHANGER	65104247		•	•			•			•	•	•	•					
	MAIN EXCHANGER	65105030			•			•											
	MAIN EXCHANGER	65106297				•			•					•					03/08
	MAIN EXCHANGER	65104247	GPO	•	•														06/08
	MAIN EXCHANGER	65105030	GPO	•	•														07/08
0112	BURNER 13NP	65104220				•			•					•					02/08
	BURNER 13NP	65104220		•	•		•	•		•	•	•	•	•	•				
	BURNER 15NP	65105027			•			•											
	BURNER 11NP	65106294				•			•					•					03/08
	BURNER 13NP	65104220	GPO	•	•														06/08
	BURNER 15NP	65105027	GPO	•	•														07/08
0113	GAS MANIFOLD	60001134	GPO			•													03/08
	GAS MANIFOLD	60001348	GPO	•	•														07/08
	GAS MANIFOLD 13 INJ. D:2.40	65105915	GPO			•													02/08
	GAS MANIFOLD 13 INJ. D:2.40	65105915	GPO	•	•														06/08
	GAS MANIFOLD 13 INJ. D:0.76	65104223	LPG			•													02/08
	GAS MANIFOLD 13 INJ. D:0.76	65104223	LPG	•															
	GAS MANIFOLD 11 INJ. D:0.80	65106605	LPG			•													03/08
	GAS MANIFOLD 13 INJ. D:1.32	65104226	NAT				•			•					•				
	GAS MANIFOLD 13 INJ. D:1.25	65104302	NAT			•			•					•					02/08
	GAS MANIFOLD 13 INJ. D:1.25	65104302	NAT	•	•			•				•	•	•					
	GAS MANIFOLD 15 INJ. D:1.25	65105026	NAT		•			•											
	GAS MANIFOLD 13 INJ. D:1.15	65105683	NAT				•			•					•				
	GAS MANIFOLD 11 INJ. D:1.32	65106302	NAT				•		•					•					03/08
0160	CLIP	61010050		•	•	•	•	•	•	•	•	•	•	•	•	•	•	•	
<b>0200</b>	<b>GAS SECTION</b>																		
0201	GAS VALVE	65105382	GPO	•	•	•													
	GAS VALVE	65104254	NAT-B/P	•	•	•	•	•	•	•	•	•	•	•	•	•	•	•	
0204	SPARK GENERATOR	65104653		•	•	•	•	•	•	•	•	•	•	•	•	•	•	•	
0210	RESTRICTOR D: 4.2	60000017	NAT								•		•						
	RESTRICTOR D: 6.3	60000018	NAT			•			•					•					02/08
	RESTRICTOR D: 6.3	60000018	NAT	•	•			•				•		•					
	RESTRICTOR D: 5.7	60000498	NAT			•			•					•					03/08
	RESTRICTOR D: 6.5	60000821	NAT		•				•										
	RESTRICTOR D: 7	65105152	NAT				•			•					•				
0214	PIPE (GAS VALVE/BURNER)	65104230		•	•	•	•	•	•	•	•	•	•	•	•	•	•	•	
0216	GROMMET	60000624		•	•	•	•	•	•	•	•	•	•	•	•	•	•	•	
0217	UNION (3/4)	65104326		•	•	•	•	•	•	•	•	•	•	•	•	•	•	•	
0218	UNION (1/2)	65104327		•	•	•	•	•	•	•	•	•	•	•	•	•	•	•	
0250	GAS TUBE	60000720		•	•	•	•	•	•	•	•	•	•	•	•	•	•	•	
0251	EPDM PIPE	65104296				•	•			•	•			•	•				
0270	GASKET (SPARK GENERATOR)	574279		•	•	•	•	•	•	•	•	•	•	•	•	•	•	•	
0280	O-RING D: 14-2.00	60000903	NAT	•	•	•	•	•	•	•	•	•	•	•	•	•	•	•	
0281	O-RING 22,22X2,62	65104304		•	•	•	•	•	•	•	•	•	•	•	•	•	•	•	
0283	O-RING 17,17X1,78	65104303		•	•	•	•	•	•	•	•	•	•	•	•	•	•	•	

300  
400

INOA - TALIA

Domestic Gas Boilers

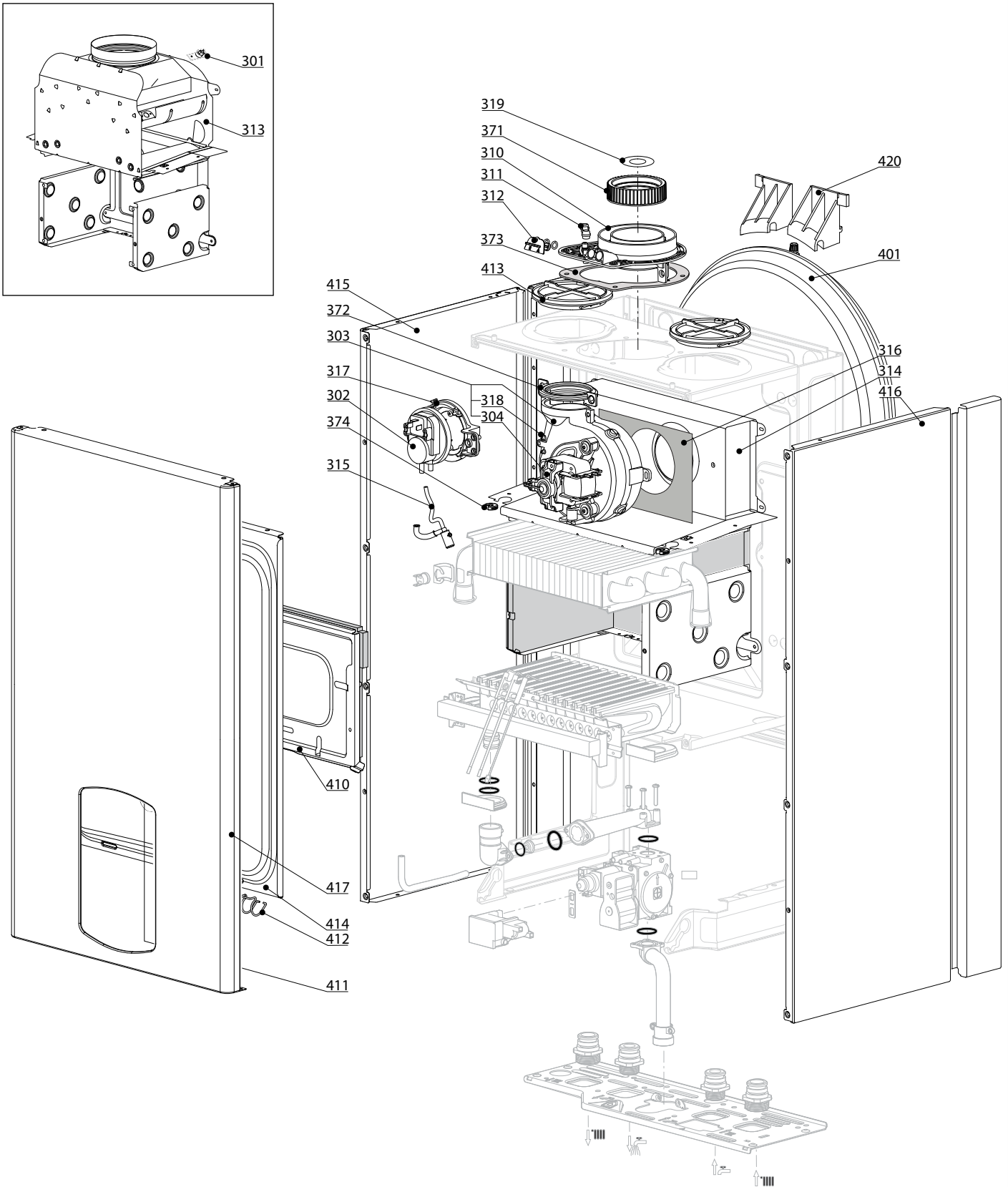

☉⇒	Description	Manf. Pt. N	Type	<div style="display: flex; justify-content: space-between; font-size: 8px; text-align: center;"> <span>INOA 25 CF</span><span>INOA 30 CF</span><span>INOA 24 VMC</span><span>INOA 25 FF</span><span>INOA 30 FF</span><span>TALIA 23 CF</span><span>TALIA 30 CF</span><span>TALIA 23 FF</span><span>TALIA 30 FF</span><span>TALIA SY SYSTEM 15 CF</span><span>TALIA SY SYSTEM 23 CF</span><span>TALIA SY SYSTEM 15 VMC</span><span>TALIA SY SYSTEM 24 VMC</span><span>TALIA SY SYSTEM 23 FF</span> </div>																		31
				1	2	3	4	5	6	7	8	9	10	11	12	13	14	15	16	17	18	
<b>0300</b>	<b>FAN ASSEMBLY</b>																					
0301	OVERHEAT THERMOSTAT 49C	61310767				•							•	•								
	THERMOSTAT 75-65°C	999539		•	•			•	•			•	•									
0302	AIR PRESSURE SWITCH 50 Pa	65104671-01					•				•				•							
	AIR PRESSURE SWITCH 74 Pa	65104672-01						•			•					•						
0303	FAN	65104231									•					•						
	FAN	65104255									•					•						
	FAN	65104357					•															
	FAN	65104452						•														
0304	HALL SENSOR 28/30/35 FF	65108255									•							•				
	HALL SENSOR 15/24/25 FF	65108301									•							•				
0310	FLUE (EXHAUST MANIFOLD / HEADER)	65105393					•	•			•	•			•	•						
0311	AIR INTAKE COVER	573329					•	•			•	•			•	•						
0312	FLUE INTAKE PLUG	65104295					•	•			•	•			•	•						
0313	COMBUSTION CHAMBER 24CF	65104218		•		•			•			•	•	•	•							
	COMBUSTION CHAMBER 28CF	65105028			•				•													
	COMBUSTION CHAMBER 24CF	65104218	GPO	•		•													06/08			
	COMBUSTION CHAMBER 28CF	65105028	GPO	•		•													07/08			
0314	COMBUSTION CHAMBER 24/28 FF	65104219				•				•					•				02/08			
	COMBUSTION CHAMBER 24/28 FF	65104219					•			•						•						
	COMBUSTION CHAMBER 24/28 FF	65106295				•				•					•				03/08			
0315	CONDENSATE TRAP	65104623				•	•			•	•			•	•							
0316	PANEL (INSULATION - FAN)	65104305				•	•			•	•			•	•							
0317	SUPPORT (AIR PRESSURE SWITCH)	65104378				•	•			•	•			•	•							
0318	VENTURI 28/30FF	65106515					•				•					•						
	VENTURI 15/24FF	65106516					•				•					•						
0319	RESTRICTOR KIT	60001598				•	•			•	•			•	•							
0371	COLLAR GASKET	65104258				•	•			•	•			•	•							
0372	FAN GASKET	65104257				•	•			•	•			•	•							
0373	GASKET	60000317				•	•			•	•			•	•							
0374	CABLE INLET RUBBER WASHER	60000716		•	•	•	•	•	•	•	•	•	•	•	•	•	•	•	•			
<b>0400</b>	<b>SEALED CASE</b>																					
0401	EXPANSION VESSEL	65104261		•	•	•	•	•	•	•	•	•	•	•	•	•	•	•	•			
0410	PANEL (COMBUSTION CHAMBER)	65104240					•			•					•				02/08			
	PANEL (COMBUSTION CHAMBER)	65104240		•		•		•			•	•	•	•		•						
	PANEL (COMBUSTION CHAMBER)	65105033			•				•													
	PANEL (COMBUSTION CHAMBER)	65106296					•			•					•				03/08			
0411	SIGHT GLASS	65104232				•	•			•	•			•	•							
0412	SPRING FRONT PANEL (KIT)	65104298				•	•			•	•			•	•							
0413	AIR RETURN COVER	65104249				•	•			•	•			•	•							
0414	PANEL (FRONT - SEALED CHAMBER)	65105679				•	•			•	•			•	•							
0415	CASE PANEL (L.H. SIDE)	65105676		•	•	•	•	•	•	•	•	•	•	•	•	•	•	•	•			
0416	CASE PANEL (R.H. SIDE)	65105677		•	•	•	•	•	•	•	•	•	•	•	•	•	•	•	•			
0417	CASE PANEL (FRONT)	60000719		•	•	•	•	•	•	•	•	•	•	•	•	•	•	•	•			
0420	EXPANSION VESSEL SUPPORT	65104696		•	•	•	•	•	•	•	•	•	•	•	•	•	•	•	•			
0421	LONGERON 61mm	60001382		•		•	•	•	•	•	•		•	•	•	•	•	•	•			

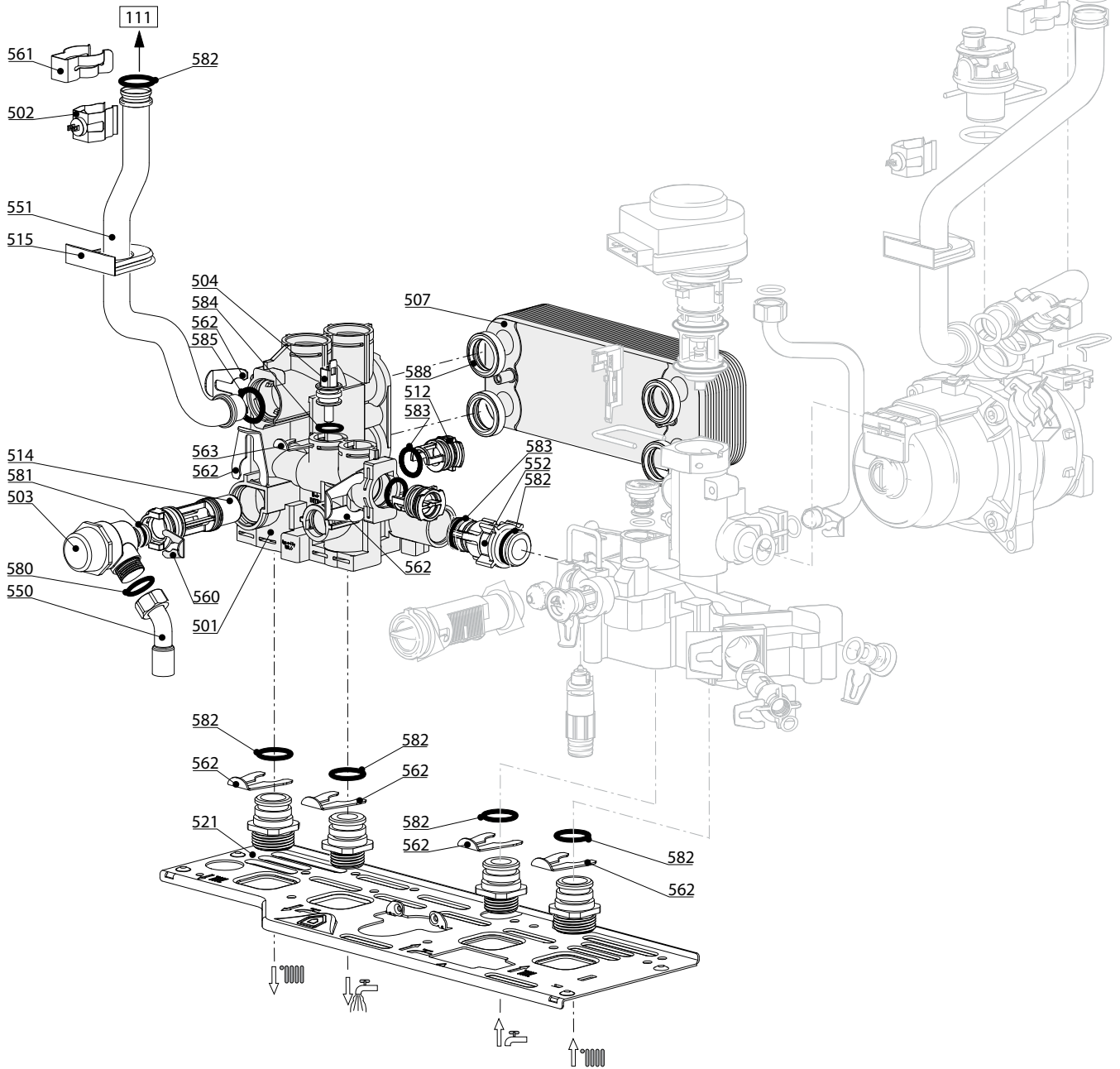
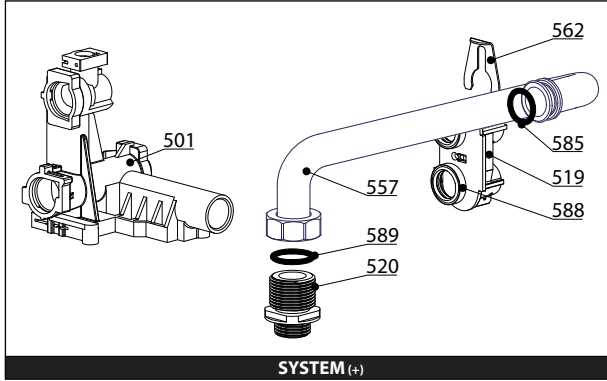

☉⇒	Description	Manf. Pt. N	Type																		
				1	2	3	4	5	6	7	8	9	10	11	12	13	14	15	16	17	18
0500	<b>FLOW GROUP</b>																				
0501	FLOW GROUP	60000844		•	•	•	•	•	•	•											
	FLOW GROUP	60000872									•	•	•	•	•						
0502	TEMPERATURE PROBE + CLIP	990686		•	•	•	•	•	•	•	•	•	•	•	•						
0503	PRESSURE RELIEF VALVE 3 BAR	61312668		•	•	•	•	•	•	•	•	•	•	•	•						
0504	NTC PROBE	65104338		•	•	•	•	•	•	•											
0507	WATER / WATER HEAT EXCHANGER 16	65104333		•	•	•	•	•	•	•											
0512	PLUG	65104445		•	•	•	•	•	•	•	•	•	•	•	•						
0514	BY-PASS	65104336		•	•	•	•	•	•	•	•	•	•	•	•						
0515	GROMMET	60000808		•	•	•	•	•	•	•	•	•	•	•	•						
0519	INTERFACE 'System' Close	65105181	SYST.								•	•	•	•	•						
	INTERFACE 'System +' Open	60001365	SYST. +								•	•	•	•	•						
0520	UNION ( 3/4-1/2)	60001367									•	•	•	•	•						
0521	HYDRAULIC GROUP SUPPORT	60001375		•	•	•	•	•	•	•											
0550	PIPE (SAFETY VALVE)	65104447		•	•	•	•	•	•	•	•	•	•	•	•						
0551	HEATING FLOW TUBE	60000722				•				•					•				02/08		
	HEATING FLOW TUBE	60000722		•	•		•	•		•	•	•	•	•							
	HEATING FLOW TUBE	60000989			•				•										03/08		
	HEATING FLOW TUBE	60001131				•			•						•				06/08		
	HEATING FLOW TUBE	60000722	GPO	•	•														07/08		
	HEATING FLOW TUBE	60000989	GPO	•	•																
0552	BY-PASS PIPE	65104340		•	•	•	•	•	•	•	•	•	•	•	•						
0557	TUBO SYSTEM	60001366									•	•	•	•	•						
0560	CLIP D:10	65104260		•	•	•	•	•	•	•	•	•	•	•	•						
0561	CLIP	61307589		•	•	•	•	•	•	•	•	•	•	•	•						
0562	CLIP D=18	65104259		•	•	•	•	•	•	•	•	•	•	•	•						
0563	CLIP	65104339		•	•	•	•	•	•	•	•	•	•	•	•						
0580	SHEET GASKET D: 13.9-10.4-1.5	60061853-02		•	•	•	•	•	•	•	•	•	•	•	•						
0581	O - RING (15.88X2.62)	65104337		•	•	•	•	•	•	•	•	•	•	•	•						
0582	O-RING D: 17.86-2.62	61308091		•	•	•	•	•	•	•	•	•	•	•	•						
0583	O - RING (15.54X2.62)	65104325		•	•	•	•	•	•	•	•	•	•	•	•						
0584	O-RING D: 11.91-2.62	60000850		•	•	•	•	•	•	•	•	•	•	•	•						
0585	O-RING 3,53X17,04	65104262		•	•	•	•	•	•	•	•	•	•	•	•						
0588	EXCHANGER GASKET	65104334		•	•	•	•	•	•	•	•	•	•	•	•						
0589	SHEET GASKET D: 24-14-1.5	60061855-17									•	•	•	•	•						

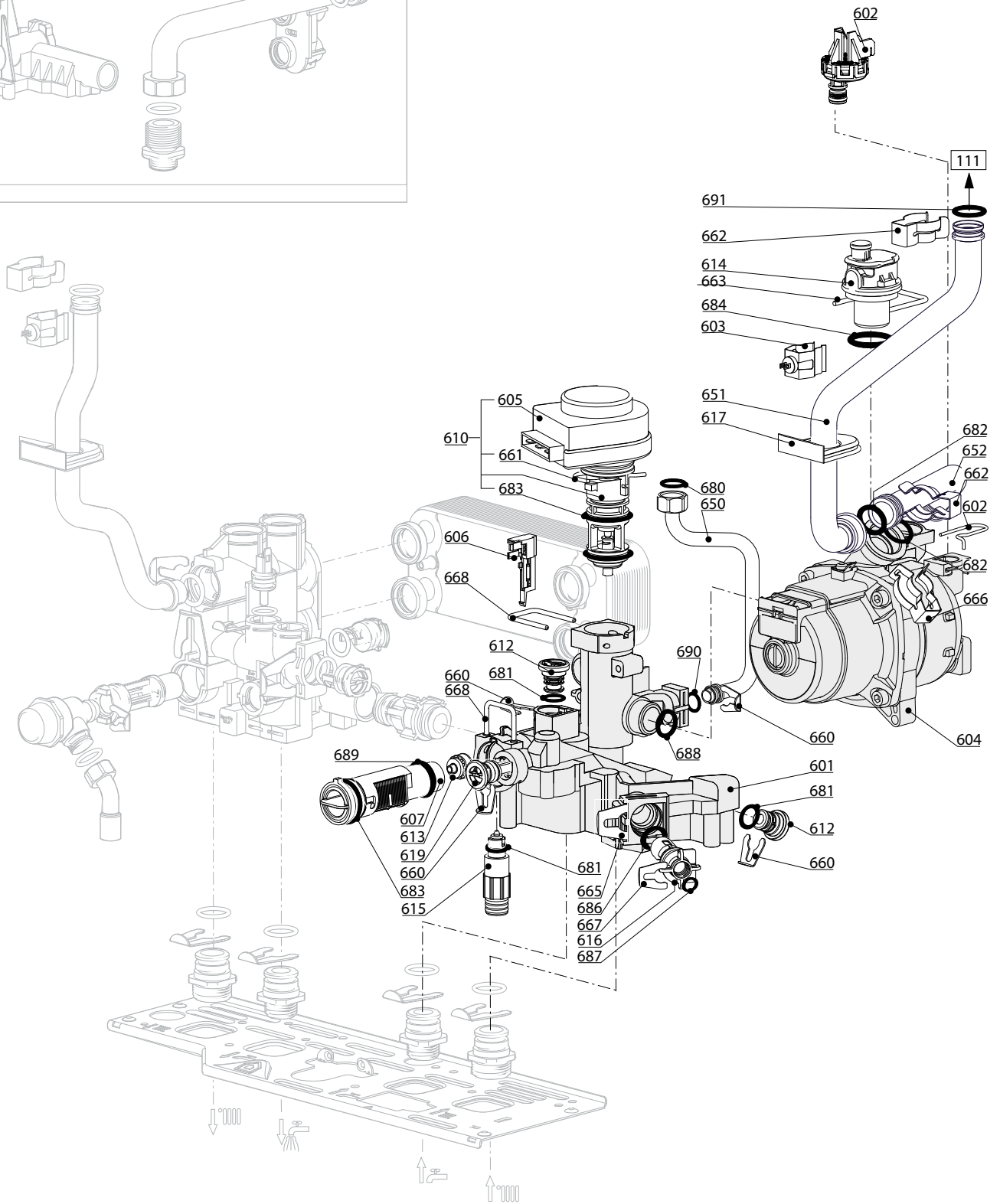
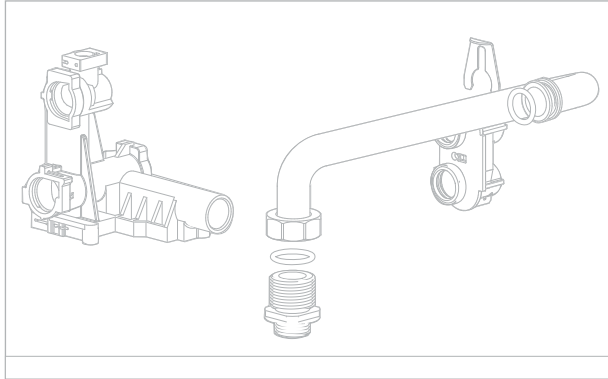



☉⇒	Description	Manf. Pt. N	Type	<div style="display: flex; justify-content: space-between; font-size: small;"> <span>INOA 25 CF</span><span>INOA 30 CF</span><span>INOA 24 VMC</span><span>INOA 25 FF</span><span>INOA 30 FF</span><span>TALIA 23 CF</span><span>TALIA 30 CF</span><span>TALIA 23 FF</span><span>TALIA 30 FF</span><span>TALIA SY SYSTEM 15 CF</span><span>TALIA SY SYSTEM 23 CF</span><span>TALIA SY SYSTEM 15 VMC</span><span>TALIA SY SYSTEM 24 VMC</span><span>TALIA SY SYSTEM 23 FF</span> </div>																		31
				1	2	3	4	5	6	7	8	9	10	11	12	13	14	15	16	17	18	
0600	<b>RETURN GROUP</b>																					
0601	RETURN GROUP	60000845		•																		
	RETURN GROUP	60000874		•	•	•	•	•	•	•	•	•	•	•	•	•	•	•	•			
0602	LOW PRESSURE SWITCH	65105090					•	•		•	•											
0603	TEMPERATURE PROBE + CLIP	990686		•	•	•	•	•	•	•		•	•	•	•	•	•	•	•			
0604	PUMP 5M 1V	60000876			•			•														
	PUMP 4M 1V	60001584		•		•																
	PUMP 5M 2V	65104319							•	•	•	•	•	•	•	•	•	•	•			
0605	MOTOR - THREE-WAY VALVE	61302483-01		•	•	•	•	•	•	•	•	•	•	•	•	•	•	•	•			
0606	SENSOR (REED)	65104323		•	•	•	•	•	•	•	•	•	•	•	•	•	•	•	•			
0607	FLOW METER	60000870		•	•	•	•	•	•	•	•											
	D.H.W. PLUG	60000902										•	•	•	•	•	•	•	•			
0610	MOTOR + SPRING 3 WAY VALVE KIT	60001583		•	•	•	•	•	•	•	•	•	•	•	•	•	•	•	•			
0612	PLUG	65104377		•	•	•	•	•	•	•	•	•	•	•	•	•	•	•	•			
0613	RIDUCTORS (KIT)	65104318		•	•	•	•	•	•	•	•											
0614	AUTO AIR VENT WITH O-RING	65104703		•	•	•	•	•	•	•	•	•	•	•	•	•	•	•	•			
0615	KIT DRAIN SCREW	60001385		•	•	•	•	•	•	•	•	•	•	•	•	•	•	•	•			
0616	WATER FILTER	60001372		•	•	•	•	•	•	•	•	•	•	•	•	•	•	•	•			
0617	GROMMET	60000807		•	•	•	•	•	•	•	•	•	•	•	•	•	•	•	•			
0619	PLUG	65104377		•	•	•	•	•	•	•	•	•	•	•	•	•	•	•	•			
0650	PIPE (EXPANSION VESSEL)	60000718		•	•	•	•	•	•	•	•	•	•	•	•	•	•	•	•			
0651	HEATING RETURN TUBE	60000723					•			•						•						
	HEATING RETURN TUBE	60000723		•		•		•			•	•	•	•	•	•						
	HEATING RETURN TUBE	60001132					•			•						•						
	PIPE (C.H. RETURN)	65104265			•					•												
	HEATING RETURN TUBE	60000723	GPO	•		•																
	PIPE (C.H. RETURN)	65104265	GPO	•		•																
0652	HEATING RETURN TUBE	60000724		•	•	•	•	•	•	•	•	•	•	•	•	•	•	•	•			
	HEATING RETURN TUBE	60000990			•				•													
	HEATING RETURN TUBE	60000724	GPO	•		•																
	HEATING RETURN TUBE	60000990	GPO	•		•																
0660	CLIP D:10	65104260		•	•	•	•	•	•	•	•	•	•	•	•	•	•	•	•			
0661	CLIP	65104332		•	•	•	•	•	•	•	•	•	•	•	•	•	•	•	•			
0662	CLIP	61307589		•	•	•	•	•	•	•	•	•	•	•	•	•	•	•	•			
0663	U-CLIP	65104704		•	•	•	•	•	•	•	•	•	•	•	•	•	•	•	•			
0664	CLIP	65104322					•	•			•	•				•	•					
0665	CLIP	65104331		•	•	•	•	•	•	•	•	•	•	•	•	•	•	•	•			
0666	CLIP	60000309		•	•	•	•	•	•	•	•	•	•	•	•	•	•	•	•			
0667	CLIP	65100680		•	•	•	•	•	•	•	•	•	•	•	•	•	•	•	•			
0668	CLIP	65104316		•	•	•	•	•	•	•	•	•	•	•	•	•	•	•	•			
0680	GASKET 3/8	573521		•	•	•	•	•	•	•	•	•	•	•	•	•	•	•	•			
0681	O - RING (9.19X2.62)	65104313		•	•	•	•	•	•	•	•	•	•	•	•	•	•	•	•			
0682	O-RING 3,53X17,04	65104262		•	•	•	•	•	•	•	•	•	•	•	•	•	•	•	•			
0683	O - RING (23.47X2.62)	65104315		•	•	•	•	•	•	•	•	•	•	•	•	•	•	•	•			
0684	O-RING	65104705		•	•	•	•	•	•	•	•	•	•	•	•	•	•	•	•			
0686	O - RING (15.54X2.62)	65104325		•	•	•	•	•	•	•	•	•	•	•	•	•	•	•	•			
0687	O RING D: 5.7-1.9	61009834-10		•	•	•	•	•	•	•	•	•	•	•	•	•	•	•	•			
0688	O - RING (21.89X2.62)	65104320		•	•	•	•	•	•	•	•	•	•	•	•	•	•	•	•			
0689	O-RING 17,17X1,78	65104303		•	•	•	•	•	•	•	•	•	•	•	•	•	•	•	•			
0690	O-RING D: 8.9-2.7	61009834-14		•	•	•	•	•	•	•	•	•	•	•	•	•	•	•	•			
0691	O-RING D: 17.86-2.62	61308091		•	•	•	•	•	•	•	•	•	•	•	•	•	•	•	•			

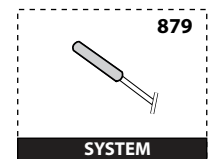
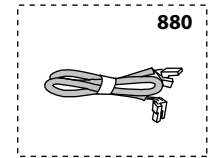
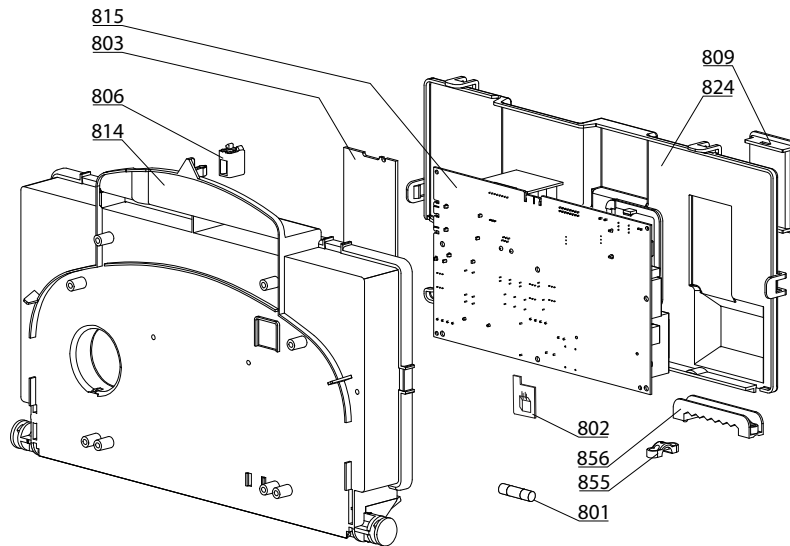

**SYSTEM**

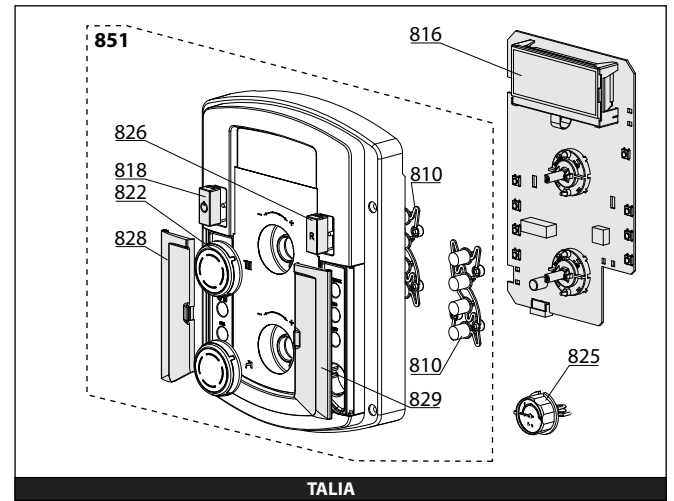
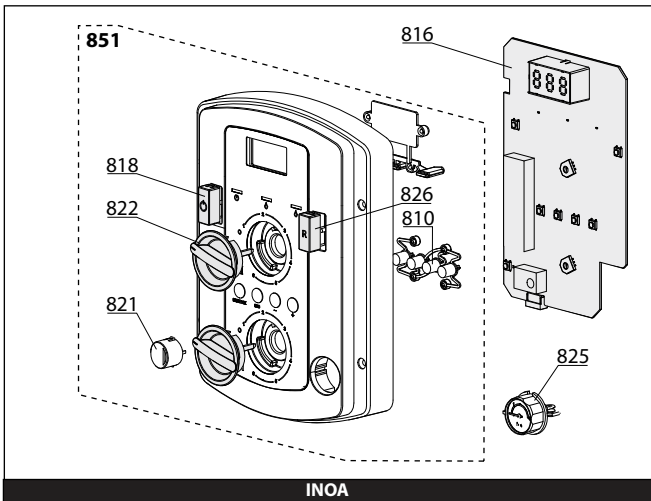

**900**

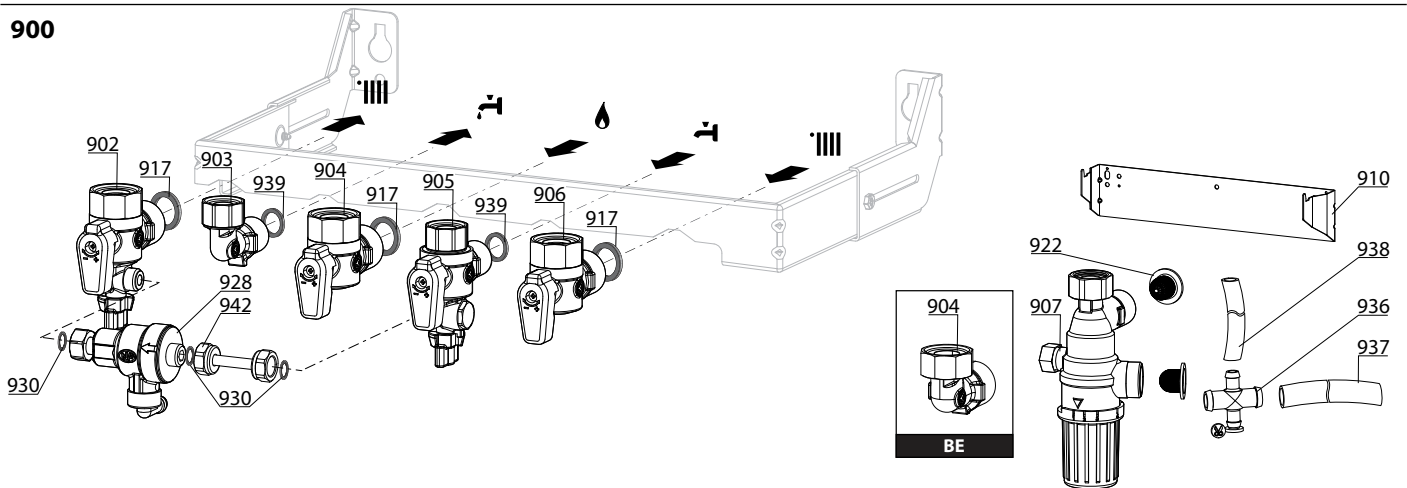

**5000**

**5001**  
 Transf. gaz > B/P  
 Conv. gas > LPG  
 Transf. gas > GPL  
 Transf. gas > B/P  
 Umrustsatz > B/P

**5002**  
 Transf. gaz > Nat  
 Conv. gas > Nat  
 Transf. gas > Met  
 Transf. gas > Met  
 Umrustsatz > Nat

**5020**  
 Options  
 Accessories  
 Opzioni  
 Accessorio  
 Option

☉➔	Description	Manf. Pt. N	Type	<div style="display: flex; justify-content: space-between; font-size: small;"> <span>INOA 25 CF</span><span>INOA 30 CF</span><span>INOA 24 VMC</span><span>INOA 25 FF</span><span>INOA 30 FF</span><span>TALIA 25 CF</span><span>TALIA 30 CF</span><span>TALIA 25 FF</span><span>TALIA 30 FF</span><span>TALIA SY STEM 15 CF</span><span>TALIA SY STEM 25 CF</span><span>TALIA SY STEM 15 VMC</span><span>TALIA SY STEM 24 VMC</span><span>TALIA SY STEM 25 FF</span> </div>																		31
				1	2	3	4	5	6	7	8	9	10	11	12	13	14	15	16	17	18	
<b>0800</b>	<b>ELECTRICAL BOX</b>																					
0801	FUSE 250V 2A - TEMPORIZED	61003456		•	•	•	•	•	•	•	•	•	•	•	•	•	•	•	•			
0802	MODULE KIT (EEPROM)	65105148		•	•	•	•	•	•	•	•	•	•	•	•	•	•	•	•			
0803	P.C.B (CLIP-IN) E-BUS	65109108		•	•	•	•	•	•	•	•	•	•	•	•	•	•	•	•			
0809	INSPECTION COVER	65104294		•	•	•	•	•	•	•	•	•	•	•	•	•	•	•	•			
0810	PUSH BUTTON	60000978		•	•	•	•	•	•	•	•	•	•	•	•	•	•	•	•			
0814	CONTROL PANEL	65104300		•	•	•	•	•	•	•	•	•	•	•	•	•	•	•	•			
0815	P.C.B. (MAIN)	65109313-02		•	•	•	•	•	•	•	•	•	•	•	•	•	•	•	•			
0816	PRINTED CIRCUIT BOARD (DISPLAY)	60000760-01						•	•	•	•	•	•	•	•	•	•	•	•			
	PRINTED CIRCUIT BOARD (DISPLAY)	60000817-01		•	•	•	•	•	•	•	•	•	•	•	•	•	•	•	•			
0818	PUSH BUTTON ON/OFF	60000809						•	•	•	•	•	•	•	•	•	•	•	•			
	PUSH BUTTON ON/OFF	60000836		•	•	•	•	•	•	•	•	•	•	•	•	•	•	•	•			
0821	PUSH BUTTON	60000835		•	•	•	•	•	•	•	•	•	•	•	•	•	•	•	•			
0822	KNOB	60000762						•	•	•	•	•	•	•	•	•	•	•	•			
	KNOB	60001003		•	•	•	•	•	•	•	•	•	•	•	•	•	•	•	•			
0824	CONTROL PANEL COVER (REAR)	65104293		•	•	•	•	•	•	•	•	•	•	•	•	•	•	•	•			
0825	PRESSURE GAUGE	60000725		•	•	•	•	•	•	•	•	•	•	•	•	•	•	•	•			
0826	BUTTON (RESET)	60000806		•	•	•	•	•	•	•	•	•	•	•	•	•	•	•	•			
0828	LEFT HAND DOOR	60000761						•	•	•	•	•	•	•	•	•	•	•	•			
0829	RIGHT HAND DOOR	60000759						•	•	•	•	•	•	•	•	•	•	•	•			
0851	FRONT CONTROL PANEL COMPLETE	60000805						•	•	•	•	•	•	•	•	•	•	•	•			
	FRONT CONTROL PANEL COMPLETE	60000833		•	•	•	•	•	•	•	•	•	•	•	•	•	•	•	•			
0855	CABLE CLAMP	571562		•	•	•	•	•	•	•	•	•	•	•	•	•	•	•	•			
0856	CABLE CLAMP	65103377		•	•	•	•	•	•	•	•	•	•	•	•	•	•	•	•			
0879	BOILER THERMISTOR TEMP. SENSOR	60000454										•	•	•	•	•	•	•	•			
0880	EARTH WIRE	65104286		•	•	•	•	•	•	•	•	•	•	•	•	•	•	•	•			
	DISPLAY WIRING	60000746	/ CN02	•	•	•	•	•	•	•	•	•	•	•	•	•	•	•	•			
	NTC - PRES. SENSOR - GAS VALVE CABLE	60000840	/ CN04	•	•	•	•	•	•	•	•	•	•	•	•	•	•	•	•			
	NTC - PRES. SENSOR - GAS VALVE CABLE	60001369	/ CN04									•	•	•	•	•	•	•	•			
	IONIZATION ELECTRODE CABLE	65104518	/ CN05	•	•	•	•	•	•	•	•	•	•	•	•	•	•	•	•			
	SHUNT CABLE	60000839	/ CN07			•								•	•							
	TACHOMETER FAN CABLE	65104709	/ CN07					•	•	•	•	•	•	•	•	•	•	•	•			
	THREE WAY VALVE CABLE	65104523	/ CN09	•	•	•	•	•	•	•	•	•	•	•	•	•	•	•	•			
	PUMP 2V CABLE 5M	65104520	/ CN10					•	•	•	•	•	•	•	•	•	•	•	•			
	PUMP 1V CABLE	65105081	/ CN10	•	•	•	•	•	•	•	•	•	•	•	•	•	•	•	•			
	FAN CABLE	65107270	/ CN10							•	•					•	•					
	CLIP-IN E-BUS WIRING	65105169	/ CN11	•	•	•	•	•	•	•	•	•	•	•	•	•	•	•	•			
	FLOW METER CABLE	60000813	/ CN14	•	•	•	•	•	•	•	•	•	•	•	•	•	•	•	•			
	FEEDER 240V	60000993	/ CN20	•	•	•	•	•	•	•	•	•	•	•	•	•	•	•	•			
	NTC - OVERHEAT THER. - PRES SWITCH CABLE	60000814	/ CN22					•	•			•	•			•	•					
	NTC PROBE - OVERHEAT THERMOSTAT CABLE	60000838	/ CN22					•						•	•							
	NTC PROBE - OVERHEAT THERMOSTAT CABLE	65104708	/ CN22	•	•			•	•			•	•									
	ROOM THERMOSTAT CABLE	60000988	/ CN25	•	•	•	•	•	•	•	•	•	•	•	•	•	•	•	•			
<b>0900</b>	<b>JIG PLATE &amp; PIPE FITTING</b>																					
0902	WATER FLOW SERVICE TAP	60000886		•	•	•	•	•	•	•	•	•	•	•	•	•	•	•	•			
0903	HOT WATER CONNECTION	60000891		•	•	•	•	•	•	•	•	•	•	•	•	•	•	•	•			
0904	GAS SERVICE TAP	60000898		•	•	•	•	•	•	•	•	•	•	•	•	•	•	•	•			
	UNION	65105631		•	•	•	•	•	•	•	•	•	•	•	•	•	•	•	•			
0905	COLD WATER TAP	60000894		•	•	•	•	•	•	•	•	•	•	•	•	•	•	•	•			
0906	WATER FLOW & RETURN SERVI. TAP	60000885		•	•	•	•	•	•	•	•	•	•	•	•	•	•	•	•			
0907	THERMOSTATIC MIXING VALVE	60001081		•	•	•	•	•	•	•	•	•	•	•	•	•	•	•	•			
0910	WALL HOOK	60000726		•	•	•	•	•	•	•	•	•	•	•	•	•	•	•	•			
0917	SHEET GASKET D: 24-17-1.5	60061855-19		•	•	•	•	•	•	•	•	•	•	•	•	•	•	•	•			
0922	FILTER	60001087		•	•	•	•	•	•	•	•	•	•	•	•	•	•	•	•			
0928	DISCONNECTOR	60000881		•	•	•	•	•	•	•	•	•	•	•	•	•	•	•	•			
0930	SHEET GASKET D: 11-5-1.5	60061853-07		•	•	•	•	•	•	•	•	•	•	•	•	•	•	•	•			
0936	UNION	60000879		•	•	•	•	•	•	•	•	•	•	•	•	•	•	•	•			
0939	SHEET GASKET D: 16.5-11-1.5	60061854-14		•	•	•	•	•	•	•	•	•	•	•	•	•	•	•	•			
0942	FILLER NECK	60001078		•	•	•	•	•	•	•	•	•	•	•	•	•	•	•	•			
<b>5000</b>	<b>ACCESSORIES</b>																					
5001	BURNER JET FULL KIT (LPG)	65104582						•			•								•			
	BURNER JET FULL KIT (LPG)	65106514										•										
	BURNER JET FULL KIT (LPG)	65106690		•		•		•		•		•						•				
	BURNER JET FULL KIT (LPG)	65106695			•				•													
5002	BURNER JET FULL KIT (NG) FR	65104585						•			•								•			
	BURNER JET FULL KIT	65106512										•										
	BURNER JET FULL KIT	65106513											•									
	BURNER JET FULL KIT (NG) FR	65106692		•		•		•		•		•						•				
5020	ROD PLATE	60000727		•	•	•	•	•	•	•	•	•	•	•	•	•	•	•	•			

## LIST OF THE ABBREVIATIONS

HW .....	: Hot water.
CW .....	: Cold water.
C .....	: Ceramic resistance (normal heating).
Ca .....	: Ceramic resistance (accelerated heating)
TP .....	: Immersion heater.
1F .....	: With fittings.
2F .....	: Without fittings.
3F .....	: With fittings and another outlet connection.
AMI .....	: With mixing valve.
SMI .....	: Without mixing valve.
PUISS .....	: Power of th appliance.
PN .....	: Appliance with normal pression.
LP .....	: Appliance with low pression.
PV .....	: Appliance with variable power.
PF .....	: Appliance with fixed power.

## IDENTIFICATION PLATE

### SERIAL NUMBER

<b>10 Characters :</b>	04 05 125 011		
		Sequential number	
		Manufacturing day	
		Year of manufacture	
<b>11 Characters :</b>	1 95 065004 - 31		
Month of manufacture :		Technical number of the appliance	
from 1 to 9 → Jan. to Sep.,		Sequential number	
O → Oct., N → Nov.,		Year of manufacture	
D → Dec.			
<b>19 Characters :</b>	08 05 0013199 900640031		
Year of manufacture		Product reference	
Month of manufacture		Sequential number	
<b>20 Characters :</b>	3675007 XX 2 07 070 00315		
Product reference		Sequential number	
Millenium of manufacture		Manufacturing day	
		Year of manufacture	
<b>21 Characters :</b>	3675007 XX 07 070 0000315		
Product reference		Sequential number	
Year of manufacture		Manufacturing day	

The indications mentioned on the prices, commercial or technical literature and the scheme are written for your guidance and are available at a given time. The CONSTRUCTOR retains the power to modify the presentation, the form, the size, the conception or the material of the products.