

# VUE ECLATEE

## CHAUFFAGE DOMESTIQUE

Modèle

### **CELTIC non RSc**

R8202211-05FR - Edition 05 - 23/11/2009

223 531	CELTIC 2.18 CF NAT - MG 2.18
223 521	CELTIC 2.18 CF B/P
223 631	CELTIC 2.18 VMC NAT - MG 2.18 VMC
223 621	CELTIC 2.18 VMC B/P
225 031	CELTIC 2.22 CF NAT - MG 2.2 b
225 021	CELTIC 2.22 CF B/P
225 631	CELTIC 2.22 VMC NAT
225 621	CELTIC 2.22 VMC B/P
213 531-01	CELTIC 1.18 NAT - MG 1.18
213 521	CELTIC 1.18 B/P
242 731	CELTIC TIG 16 NAT - MGB TIG 16
242 721	CELTIC TIG 16 B/P
216 431	CELTIC 1.22 NAT - MG 1.22 b
200000 216 421	CELTIC 1.22 B/P
245 031	CELTIC TIG 20 NAT - MGB TIG 20
245 021	CELTIC TIG 20 B/P
225 231-01	CELTIC 2.20 RS NAT - MGS 2.20
225 221-01	CELTIC 2.20 RS B/P
215 231	CELTIC 1.20 RS NAT
215 221	CELTIC 1.20 RS B/P
245 231	CELTIC TIG 20 RS NAT
245 221	CELTIC TIG 20 RS B/P
225 035	CELTIC 2.20 BF NAT
225 025	CELTIC 2.20 BF B/P
225 131-02	CELTIC 2.20 VE CFNAT - MGE 2.20
225 121-02	CELTIC 2.20 VE CF B/P
225 137-02	CELTIC 2.20 VE FF NAT - MGE 2.10 VF
225 127-02	CELTIC 2.20 VE FF B/P
227 531	CELTIC 2.30 CF NAT - MG 2.30
227 521	CELTIC 2.30 CF B/P
217 531	CELTIC 1.30 CF NAT - MG 1.30
217 521	CELTIC 1.30 CF B/P
245 435	CELTIC TIG 20 BF NAT
245 425	CELTIC TIG 20 BF B/P
247 531	CELTIC TIG 30 CF NAT
247 521	CELTIC TIG 30 CF B/P

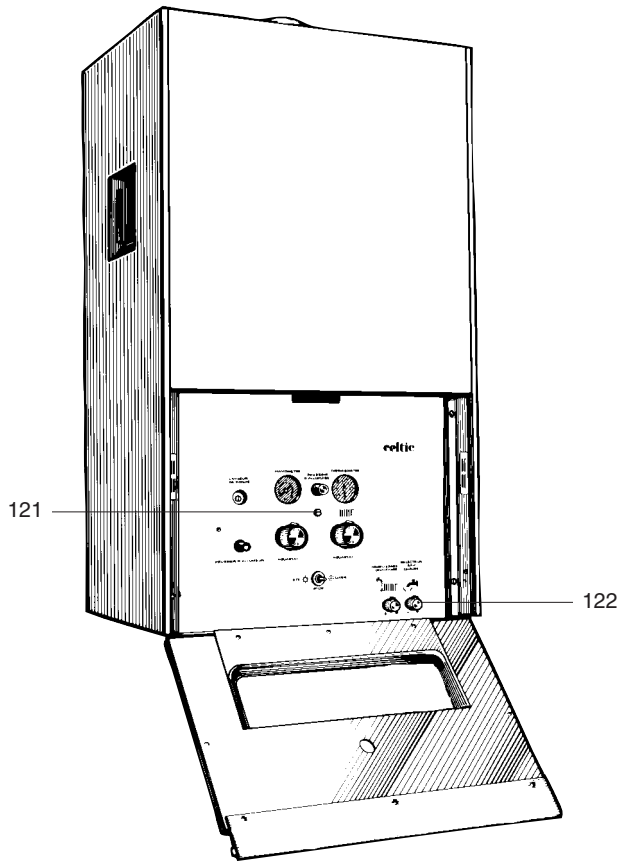

115



116

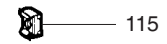
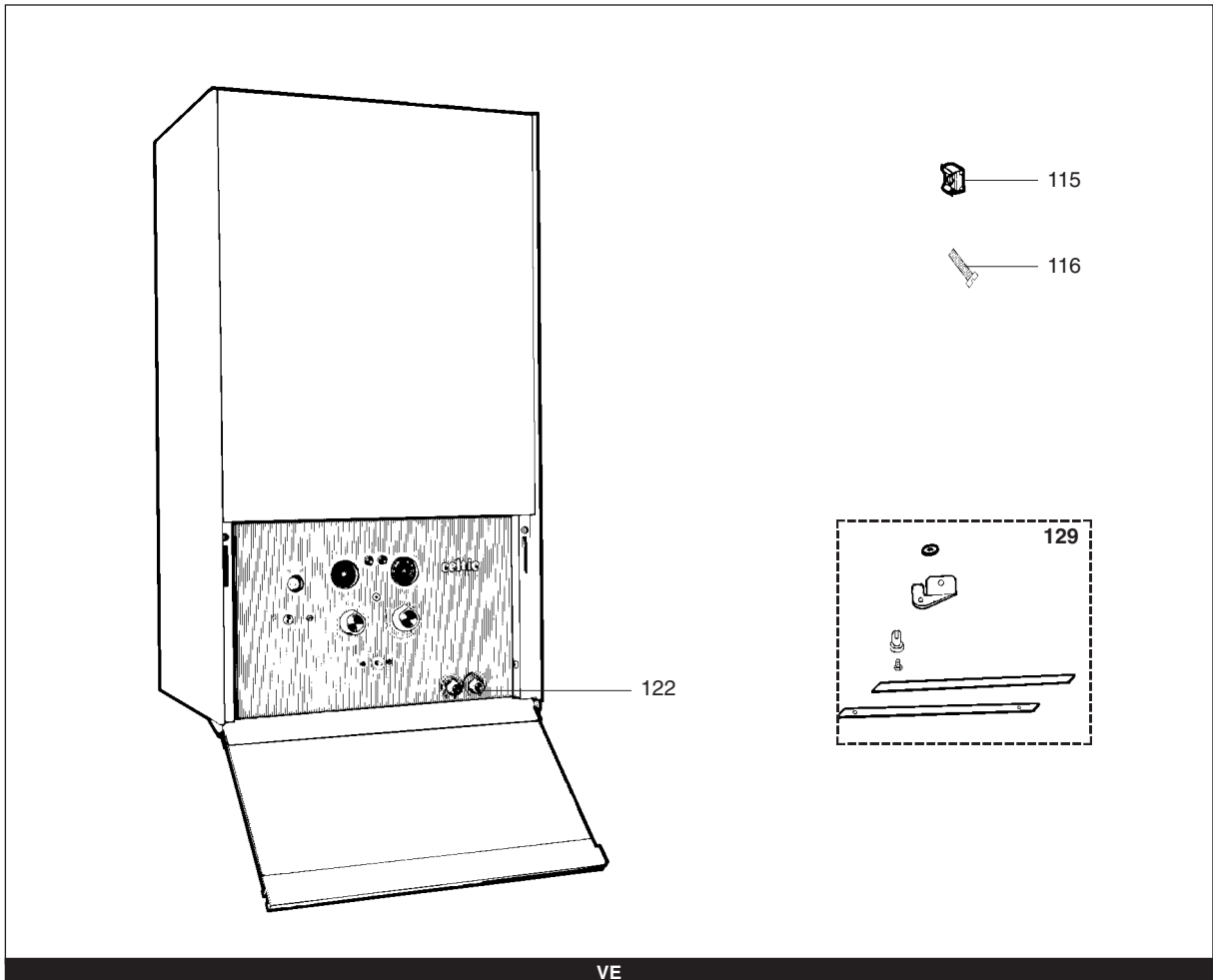

115



116

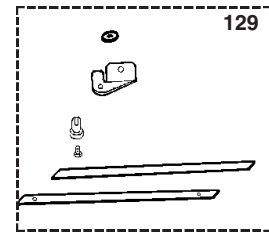

129

Rep.	Désignation	Référence	Type	2-18		2-22		1-18		TIG 16		1-22		TIG 20		2-20		1-20		TIG 20		2-20		TIG 20		2-20		1-30		TIG 30		2-20 VE		Date	
				CF	VMC	CF	VMC	CF	CF	CF	CF	CF	CF	CF	CF	CF	CF	CF	CF	CF	CF	CF	CF	CF	CF	CF	CF	CF	CF	CF	CF	CF	CF	de	à
0100	<b>HABILLAGE</b>																																		
0115	ECROU EN CAGE M 6	60004806-03		•	•	•	•	•	•	•	•	•	•	•	•	•	•	•	•	•	•	•	•	•	•	•	•	•	•	•	•	•	•		
0116	VIS A TOLE CBLZ D: 3.9-9.5	60050460-03	NOTA 1																																
	VIS M 6-10	60031527-03	NOTA 2	•	•	•	•	•	•	•	•	•	•	•	•	•	•	•	•	•	•	•	•	•	•	•	•	•	•	•	•	•	•		
0121	VIS CLS M 6-14	60014044		•	•	•	•	•	•	•	•	•	•	•	•	•	•	•	•	•	•	•	•	•	•	•	•	•	•	•	•	•	•		
0122	BOUTON VALVE DISTRIBUT. BLEU	60038009		•	•	•	•					•																							
	BOUTON VALVE DISTRIBUT. BLEU	60039217																																	
0129	REFECTION CHARNIERE (Pochette)	60081494																																	

NOTA 1 : 52 cm  
NOTA 2 : 58 cm

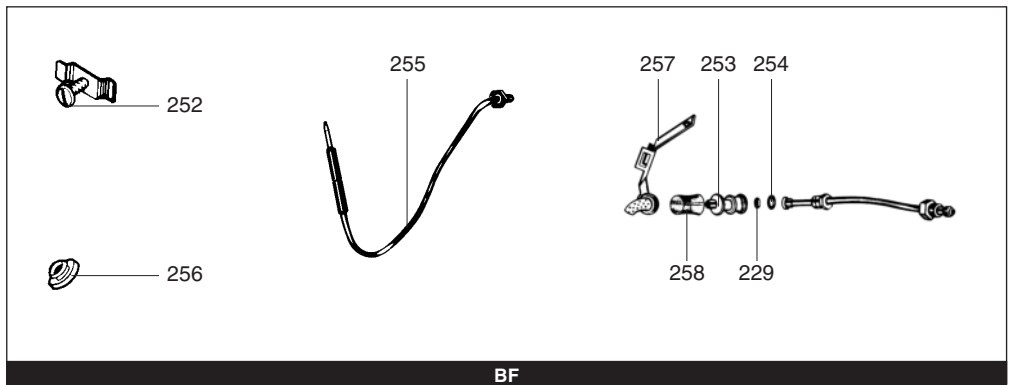
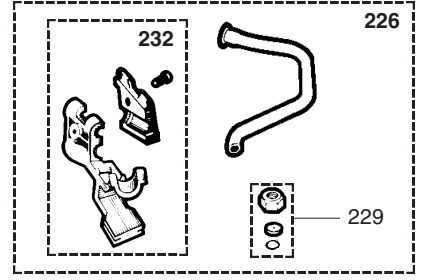
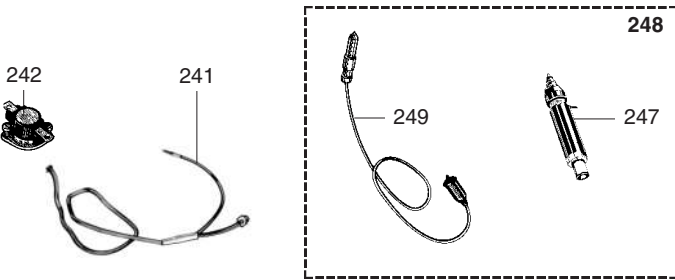
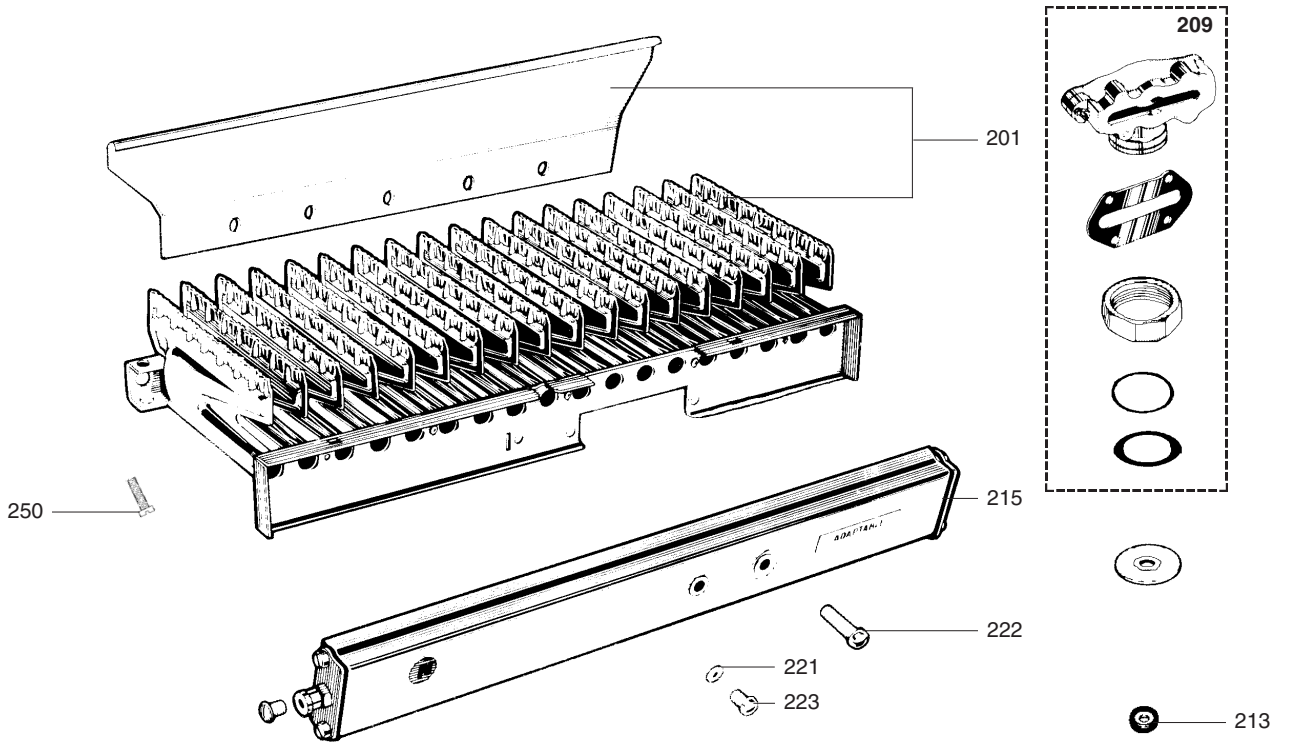

BF

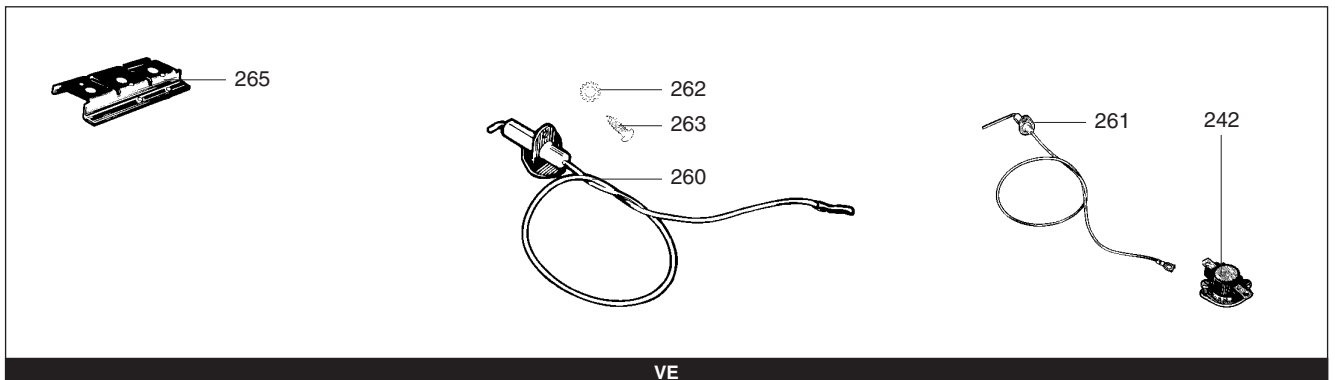

VE



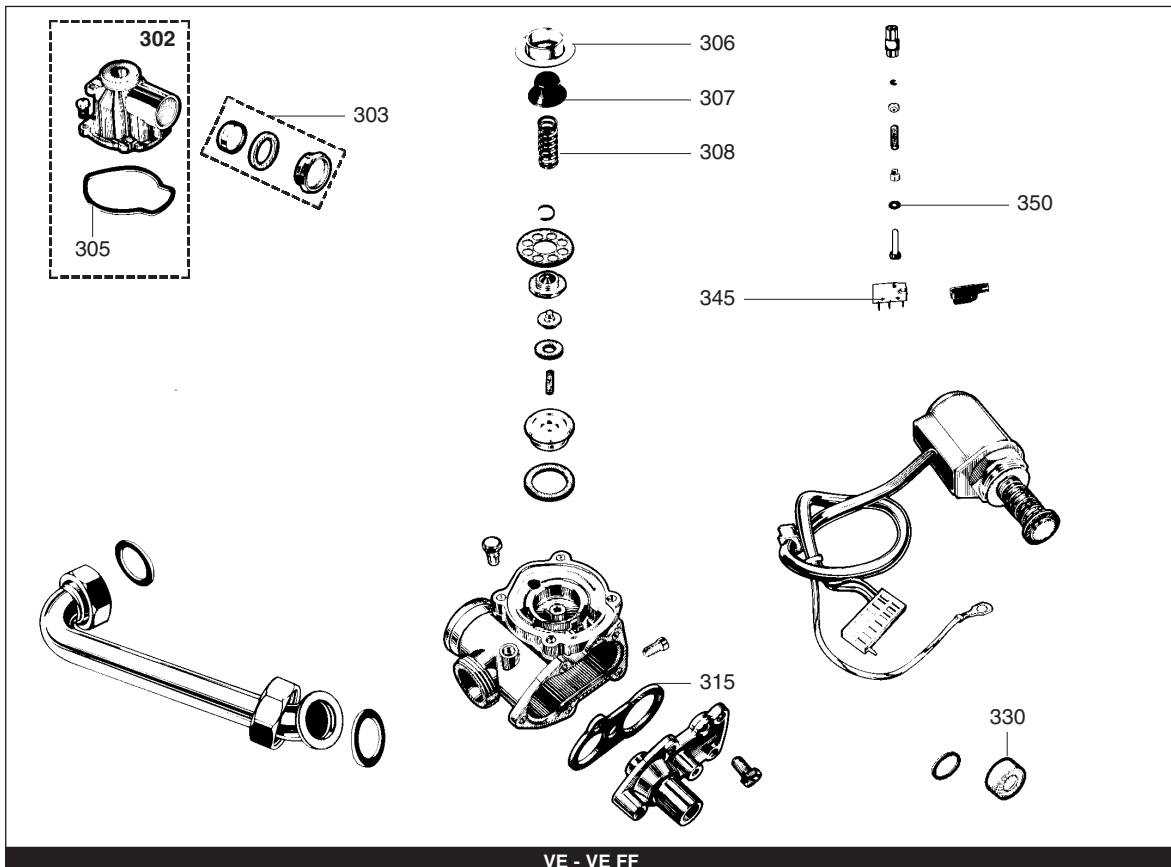
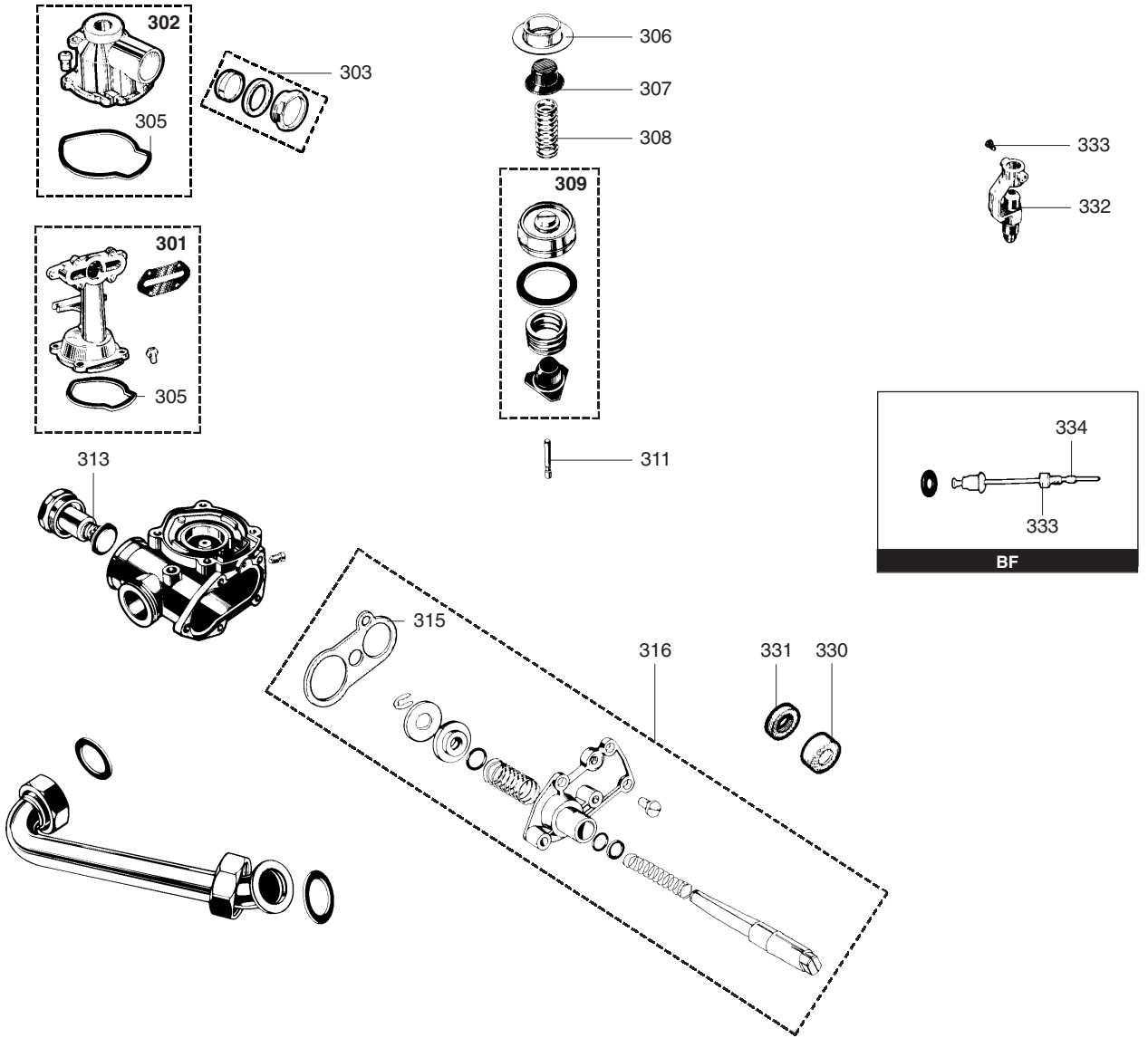

VE - VE FF



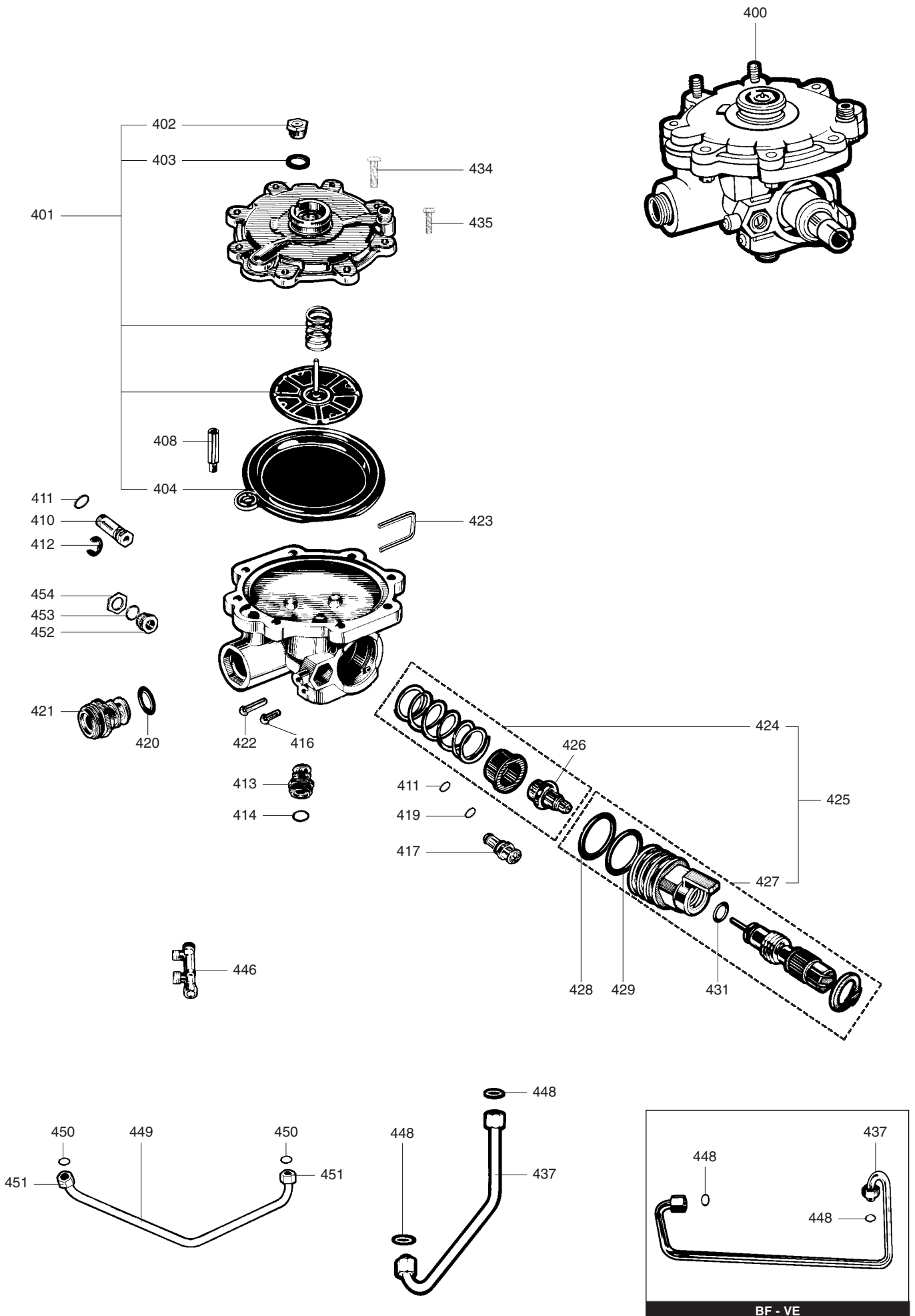



Rep.	Désignation	Référence	Type	2-18		2-22		1-18		TIG 16		1-22		TIG 20		2-20		1-20		TIG 20		RS		BF		30		VE			
				CF	VMC	CF	VMC	CF	CF	CF	CF	CF	CF	CF	CF	CF	CF	CF	CF	CF	CF	CF	CF	CF	CF	CF	CF	CF	CF	CF	CF
				Date		de		à																							
0400	VALVE EAU THERMOSTATIQUE	60030905																													
	VALVE EAU THERMOS.(SS R.P.A.)	60031408		•	•	•	•																								
	VALVE EAU THER.(AVEC Rob.P.A.)	60042739		•	•	•	•																								
	VALVE EAU THERMOSTATIQUE	60042741																													
0401	REFECTION VALVE EAU (Pochette)	60100605-30		•	•	•	•	•	•	•	•	•	•	•	•	•	•	•	•	•	•	•	•	•	•	•	•	•	•		
0402	PRESSE ETOUPE	60022639		•	•	•	•	•	•	•	•	•	•	•	•	•	•	•	•	•	•	•	•	•	•	•	•	•	•		
0403	JOINT PLAT D: 14.8-10.3-1.5	60061854-11		•	•	•	•	•	•	•	•	•	•	•	•	•	•	•	•	•	•	•	•	•	•	•	•	•	•		
0404	MEMBRANE	60022171-10		•	•	•	•	•	•	•	•	•	•	•	•	•	•	•	•	•	•	•	•	•	•	•	•	•	•		
0408	TUBE COMMUNICATION	60025043																													
	TUBE COMMUNICATION	60026418		•	•	•	•																								
0410	RACCORD M 10x100	60042549		•	•	•	•	•	•	•	•	•	•	•	•	•	•	•	•	•	•	•	•	•	•	•	•	•	•		
0411	JOINT TORIQUE D: 7.2-1.9	60024183-12		•	•	•	•	•	•	•	•	•	•	•	•	•	•	•	•	•	•	•	•	•	•	•	•	•	•		
0412	CIRCLIPS EXT D: 8	60020769-23		•	•	•	•	•	•	•	•	•	•	•	•	•	•	•	•	•	•	•	•	•	•	•	•	•	•		
0413	RACCORD SURPRESSION POUR TUBE	60042550-08		•	•	•	•																								
0414	JOINT TORIQUE D: 5.7-1.9	60024183-10		•	•	•	•	•	•	•	•	•	•	•	•	•	•	•	•	•	•	•	•	•	•	•	•	•	•		
0416	CLOU CANNELE D: 3-16	60042551		•	•	•	•	•	•	•	•	•	•	•	•	•	•	•	•	•	•	•	•	•	•	•	•	•	•		
0417	BY-PASS	60042553		•	•	•	•																								
0419	JOINT TORIQUE D: 4.9-1.9	60024183-09		•	•	•	•																								
0420	JOINT TORIQUE D: 12.1-2.7	60024183-16		•	•	•	•	•	•	•	•	•	•	•	•	•	•	•	•	•	•	•	•	•	•	•	•	•	•		
0421	RACCORD M 1/2	60023623		•	•	•	•	•	•	•	•	•	•	•	•	•	•	•	•	•	•	•	•	•	•	•	•	•	•		
0422	CLOU CANNELE D: 3-10	60042552		•	•	•	•																								
0423	CLIP	60023537-03		•	•	•	•	•	•	•	•	•	•	•	•	•	•	•	•	•	•	•	•	•	•	•	•	•	•		
0424	ELEMENT THERMOSTATIQUE (Poch.)	60100602-30		•	•	•	•	•	•	•	•	•	•	•	•	•	•	•	•	•	•	•	•	•	•	•	•	•	•		
	ELEMENT THERMOSTATIQUE (Poch.)	60038991	NOTA 1	•	•	•	•																								
0425	ELEMENT DE MANOEUVRE (Poch.)	60100600-30		•	•	•	•	•	•	•	•	•	•	•	•	•	•	•	•	•	•	•	•	•	•	•	•	•	•		
	ELEMENT DE MANOEUVRE (Poch.)	60100601-30		•	•	•	•																								
0426	ELEMENT THERMOSTATIQUE	60034779		•	•	•	•	•	•	•	•	•	•	•	•	•	•	•	•	•	•	•	•	•	•	•	•	•	•		
0427	ELEMENT DE MANOEUVRE	60034799		•	•	•	•	•	•	•	•	•	•	•	•	•	•	•	•	•	•	•	•	•	•	•	•	•	•		
0428	JOINT TORIQUE D: 21.3-3.6	60024183-25		•	•	•	•	•	•	•	•	•	•	•	•	•	•	•	•	•	•	•	•	•	•	•	•	•	•		
0429	JOINT TORIQUE D: 23-3.6	60024183-32		•	•	•	•	•	•	•	•	•	•	•	•	•	•	•	•	•	•	•	•	•	•	•	•	•	•		
0431	JOINT TORIQUE D: 7.2-1.9	60024164-12		•	•	•	•	•	•	•	•	•	•	•	•	•	•	•	•	•	•	•	•	•	•	•	•	•	•		
0434	VIS M 5-25	60031035-03		•	•	•	•	•	•	•	•	•	•	•	•	•	•	•	•	•	•	•	•	•	•	•	•	•	•		
0435	VIS M 5-15	60031088-03		•	•	•	•	•	•	•	•	•	•	•	•	•	•	•	•	•	•	•	•	•	•	•	•	•	•		
0437	TUBE DE SURPRESSION	60035995-08		•	•	•	•	•	•	•	•	•	•	•	•	•	•	•	•	•	•	•	•	•	•	•	•	•	•		
0446	ROBINET PUISS.AJUSTABLE	60031227		•	•	•	•																								
0448	JOINT PLAT D: 8.5-4.1-1.5	60061852-12		•	•	•	•	•	•	•	•	•	•	•	•	•	•	•	•	•	•	•	•	•	•	•	•	•	•		
0450	BAGUE BICONE D: 6	60022865		•	•	•	•																								
	JOINT PLAT D: 18.2-14-1.5	60061855-16						•	•	•	•	•	•	•	•	•	•	•	•	•	•	•	•	•	•	•	•	•	•		
0451	ECROU H M 10-1	60022864-08		•	•	•	•																								
0453	JOINT TORIQUE D: 15.1-2.7	60024183-19		•	•	•	•																								
0454	CONTRE ECROU H 1/2"	60034780-08		•	•	•	•																								

NOTA 1 : ANCIENNE CARTOUCHE.

CELTIC non RSC

Chauffage Domestique

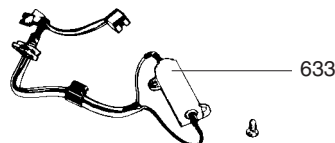
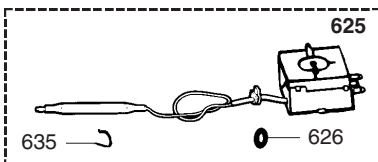
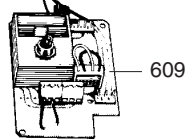
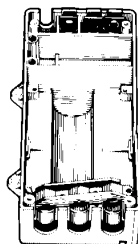
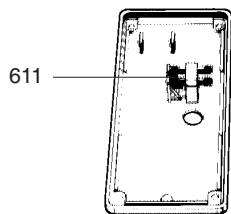
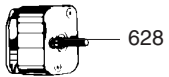
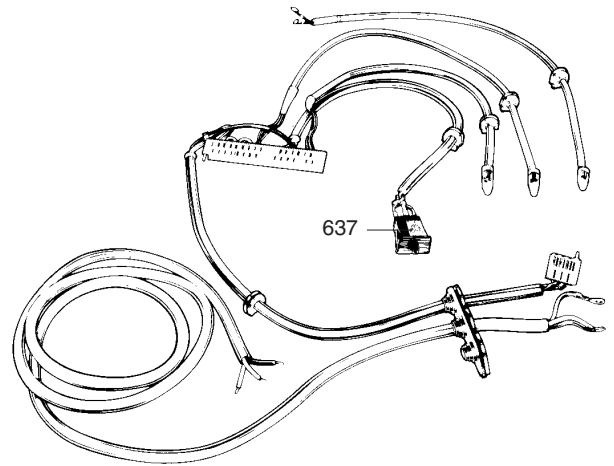
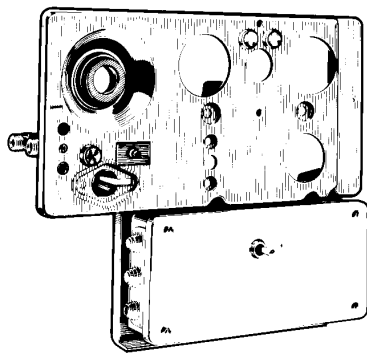
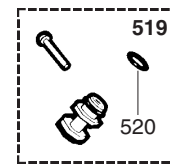
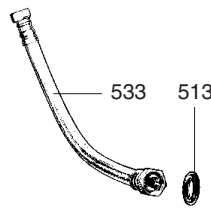
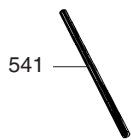
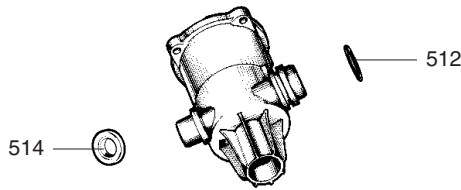
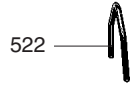
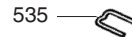
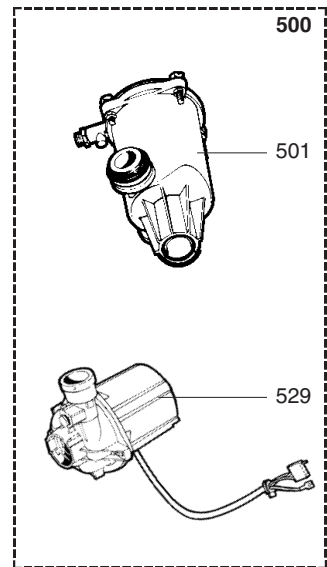
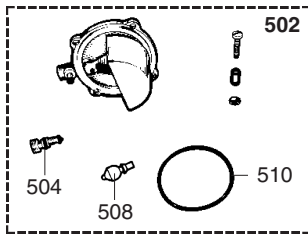
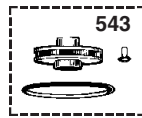
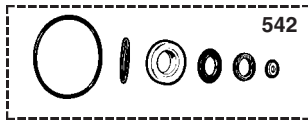

Rep.	Désignation	Référence	Type	2-18		2-22		1-18		TIG 16		1-22		TIG 20		1-20		TIG 20		RS		BF		30		VE			
				CF	VMC	CF	VMC	CF	CF	CF	CF	CF	CF	CF	CF	CF	CF	CF	CF	CF	CF	CF	CF	CF	CF	CF	CF	CF	CF
				Date		de		à																					
<b>0500</b>	<b>CIRCULATEUR + DEGAZEUR ENS</b>	60056685																											
	CIRCULATEUR (EQUIPEMENT)	60060097		•	•	•	•	•	•	•	•	•	•	•	•	•	•	•	•	•	•	•	•	•	•	•	•		
0501	DEGAZEUR COMPLET	60037374		•	•	•	•	•	•	•	•	•	•	•	•	•	•	•	•	•	•	•	•	•	•	•	•		
0502	COUVERCLE DEGAZEUR (Pochette)	60035748		•	•	•	•	•	•	•	•	•	•	•	•	•	•	•	•	•	•	•	•	•	•	•	•		
0504	PURGEUR EQUIPE (Pochette)	60081421		•	•	•	•	•	•	•	•	•	•	•	•	•	•	•	•	•	•	•	•	•	•	•	•		
0508	CLAPET DEGAZEUR	60035750		•	•	•	•	•	•	•	•	•	•	•	•	•	•	•	•	•	•	•	•	•	•	•	•		
0510	JOINT DE FORME ((Degazeur)	60053847		•	•	•	•	•	•	•	•	•	•	•	•	•	•	•	•	•	•	•	•	•	•	•	•		
0512	JOINT TORIQUE D: 27.8-3.6	60024164-35		•	•	•	•	•	•	•	•	•	•	•	•	•	•	•	•	•	•	•	•	•	•	•	•		
0513	JOINT TORIQUE D: 16-5	60024959-12		•	•	•	•	•	•	•	•	•	•	•	•	•	•	•	•	•	•	•	•	•	•	•	•		
0514	SILENCIEUX	60025136		•	•	•	•	•	•	•	•	•	•	•	•	•	•	•	•	•	•	•	•	•	•	•	•		
0515	AMORTISSEUR	60049974		•	•	•	•	•	•	•	•	•	•	•	•	•	•	•	•	•	•	•	•	•	•	•	•		
0516	RACCORD DE DEGAZEUR (Pochette)	60081020		•	•	•	•	•	•	•	•	•	•	•	•	•	•	•	•	•	•	•	•	•	•	•	•		
0519	BOUCHON SURPRESSION (Pochette)	60081332		•	•	•	•	•	•	•	•	•	•	•	•	•	•	•	•	•	•	•	•	•	•	•	•		
	RACCORD DE SURPRESSION (Poch.)	60081511																											
0520	JOINT TORIQUE D: 5.7-1.9	60024183-10		•	•	•	•	•	•	•	•	•	•	•	•	•	•	•	•	•	•	•	•	•	•	•	•		
0522	CLIP	60030898-03		•	•	•	•	•	•	•	•	•	•	•	•	•	•	•	•	•	•	•	•	•	•	•	•		
0529	CIRCULATEUR 1 VITESSE (D)	60073887		•	•	•	•	•	•	•	•	•	•	•	•	•	•	•	•	•	•	•	•	•	•	•	•		
0532	FILTRE	60036677		•	•	•	•	•	•	•	•	•	•	•	•	•	•	•	•	•	•	•	•	•	•	•	•		
0533	DURIT	60060039		•	•	•	•	•	•	•	•	•	•	•	•	•	•	•	•	•	•	•	•	•	•	•	•		
0535	CLIP	60031764		•	•	•	•	•	•	•	•	•	•	•	•	•	•	•	•	•	•	•	•	•	•	•	•		
0541	TUBE PVC D:9 LG 315	60030900		•	•	•	•	•	•	•	•	•	•	•	•	•	•	•	•	•	•	•	•	•	•	•	•		
0542	JOINTS DE DEGAZEUR (Pochette)	60081024		•	•	•	•	•	•	•	•	•	•	•	•	•	•	•	•	•	•	•	•	•	•	•	•		
0543	TURBINE DE CIRCULATEUR D:63 Poch	60100802-30		•	•	•	•	•	•	•	•	•	•	•	•	•	•	•	•	•	•	•	•	•	•	•	•		
	TURBINE DE CIRCULATEUR D:55 Poch	60100804-30		•	•	•	•	•	•	•	•	•	•	•	•	•	•	•	•	•	•	•	•	•	•	•	•		
<b>0600</b>	<b>BOITIER ELECTRIQUE</b>																												
0607	CONDENSATEUR 2 MF	60028463		•	•	•	•	•	•	•	•	•	•	•	•	•	•	•	•	•	•	•	•	•	•	•	•		
	CONDENSATEUR 1 VITESSE	60028464																											
0609	CIRCUIT IMPRIME	60030179		•	•	•	•																						
	CIRCUIT IMPRIME	60030180						•																					
	CIRCUIT IMPRIME	60030181							•																				
	CIRCUIT IMPRIME	60043136																											
0611	FUSIBLE 220V 630mA	60028472		•	•	•	•	•	•	•	•	•	•	•	•	•	•	•	•	•	•	•	•	•	•	•	•		
	FUSIBLE 220V 1A	60041557																											
0613	VIS A TOLE D: 3.56-16	60045654		•	•	•	•	•	•	•	•	•	•	•	•	•	•	•	•	•	•	•	•	•	•	•	•		
0625	AQUASTAT 57°C (Pochette)	60100606-30		•	•	•	•																						
	THERMOSTAT (Pochette)	60100607-30																											
0626	JOINT TORIQUE D: 7.2-1.9	60024164-12		•	•	•	•																						
0628	CHRONORUPTEUR 14H	60030697		•	•	•	•	•	•	•	•																		
0630	VIS M 4-6	60019197-03		•	•	•	•	•	•	•	•																		
0633	RESISTANCE CABLEE 680 OHMS	60030886		•	•	•	•																						
0635	CLIP	60031546		•	•	•	•																						
0637	DISJONCTEUR	60037021																											

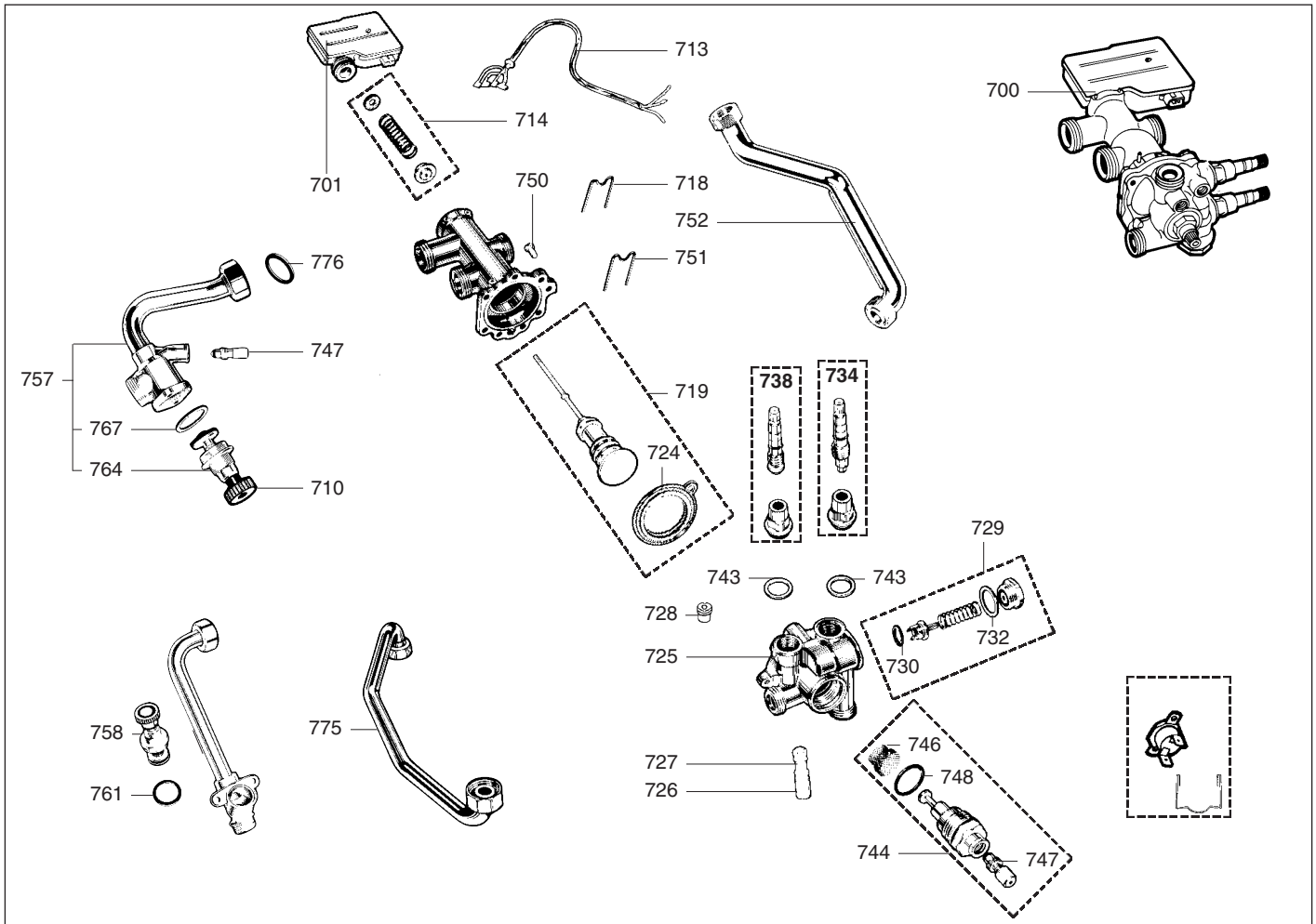

1.XX & 2.XX

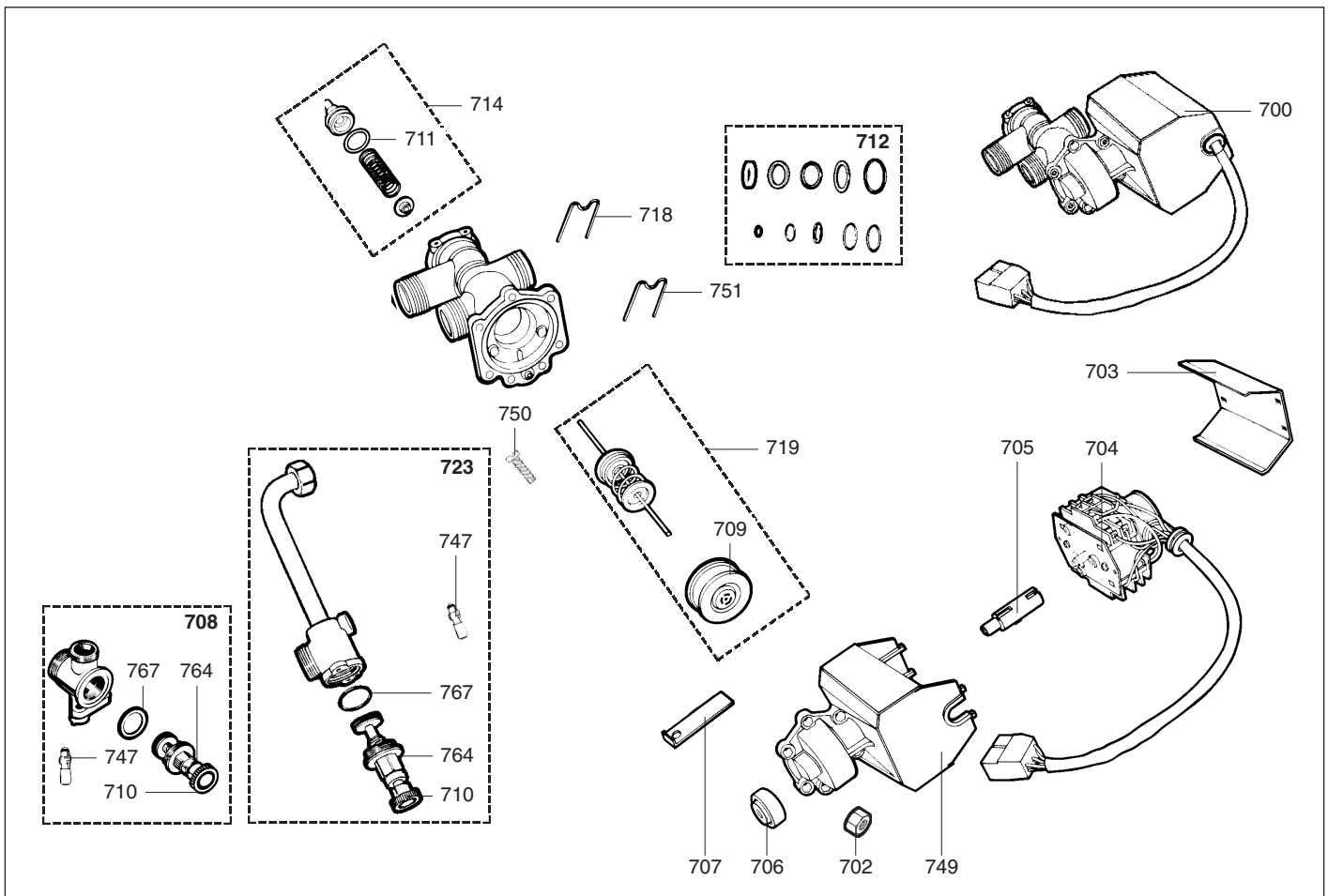

TIG

Rep.	Désignation	Référence	Type	2-18		2-22		1-18		TIG 16		1-22		TIG 20		2-20		1-20		TIG 20		RS		BF		30		VE				
				CF	VMC	CF	VMC	CF	CF	CF	CF	CF	CF	CF	CF	CF	CF	CF	CF	CF	CF	CF	CF	CF	CF	CF	CF	CF	CF	CF	CF	CF
				Date		Date		Date		Date		Date		Date		Date		Date		Date		Date		Date		Date		Date		Date		Date
0700	VALVE DISTRIBUTRICE ENS	60030586		•	•																											
	VALVE DISTRIBUTRICE ENS	60031411			•																											
	VALVE DISTRIBUTRICE ENS - FR	60045596			•																											
	VALVE DISTRIBUTRICE TI	60045652						•		•																						
0701	BOITIER MICRORUPTEUR	60031107-10		•	•	•	•																									
	BOITIER MICRORUPTEUR	60046713																														
0702	ECROU H M 5-0.80	60008664-13						•		•																						
0703	COUVERCLE COTE MOTEUR	60026207						•		•																						
0704	MOTEUR REDUCTEUR	60045350						•		•																						
0705	AXE CAME	60026202						•		•																						
0706	CAME MANOEUVRE	60026203						•		•																						
0707	LAME VD TI	60026206						•		•																						
0708	ROBINET	60031721						•		•																						
0709	JOINT TORIQUE D: 25-2.4	60024164-32						•		•																						
0710	BOUTON DE MANOEUVRE	60066107		•	•	•	•			•																						
0711	JOINT TORIQUE D: 19.8-3.6	60024164-24						•		•																						
0712	JOINTS VALVE DISTRIBUT (Poch.)	60081176						•		•																						
0713	CABLAGE VALVE DISTRIBUTRICE	60031298		•	•	•	•																									
0714	CLAPET CIRCUIT COURT (Poch.)	60081178		•	•	•	•																									
	CLAPET (Pochette)	60081513						•		•																						
0718	CLIP	60031764		•	•	•	•			•																						
0719	CLAPET CHAUFFAGE (Pochette)	60081514						•		•																						
	CLAPET CHAUFFAGE (Pochette)	60100506-30		•	•	•	•																									
0723	TUBE DEPART CHAUFFAGE	60045476						•		•																						
0724	MEMBRANE	60025809-30		•	•	•	•																									
0725	FOND DE VALVE DISTRI. USINE	60030587-08		•	•	•																										
	CORPS VALVE DISTRIBUTRICE	60035278-08																														
	FOND DE VD EQUIPE (Pochette)	60081528																														
0726	VENTURI D: 5.2	60031664-08		•	•																											
	VENTURI D: 5.4	60032803-08																														
0727	JOINT TORIQUE D: 8.9-1.9	60024164-13		•	•	•	•																									
0728	DIAPHRAGME EAU D: 4.42	60023206-03																														
	DIAPHRAGME EAU D: 4.05	60023206-04		•	•																											
0729	CLAPET BY-PASS (Pochette)	60081182		•	•	•	•																									
0730	JOINT PLAT D: 15-8.5-1.5	60030867		•	•	•	•																									
0732	JOINT PLAT D: 23.9-20.1-1.5	60061855-03		•	•	•	•																									
0734	SELECTEUR DE TEMPERATURE ENS	60030958		•	•																											
	SELECTEUR DE TEMPERATURE ENS	60031993																														
0738	ROBINET DE REMPLISSAGE	60030959		•	•	•	•																									
0743	JOINT PLAT D: 20.1-17.1-1.5	60061855-09		•	•	•	•																									
0744	REGULATEUR EAU	60031055		•	•	•	•																									
0746	FILTRE	60031226		•	•	•	•																									
0747	PURGEUR EQUIPE (Pochette)	60081028		•	•	•	•			•																						
0748	JOINT TORIQUE D: 22-2	60024959-03		•	•	•	•																									
0749	CARTER MOTO REDUCTEUR	60026003																														
0750	VIS H M 5-20	60019317																														
	VIS HX M 5-12	61010131		•	•	•	•																									
0751	CLIP	60025076-03		•	•	•	•																									
0757	TUBE DEPART CHAUFFAGE	60073662		•	•	•	•																									
0758	TETE DE ROBINET ENS	60069115		•	•	•	•																									
0761	JOINT PLAT D: 24.3-21-1.5	60061856-13		•	•	•	•																									
0764	TETE DE ROBINET ENS	60067704		•	•	•	•																									
0767	JOINT PLAT D: 29.6-25.5-1.5	60061856-04		•	•	•	•																									
0775	TUBE EAU FROIDE VD A ECHANGEUR	61001209		•	•	•	•																									
0776	JOINT TORIQUE D: 16-1.9	60024183-37		•	•	•	•																									

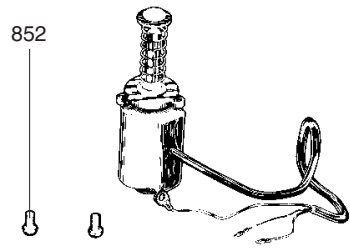
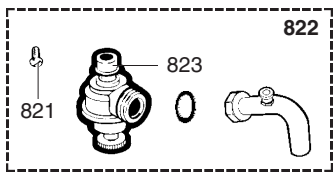
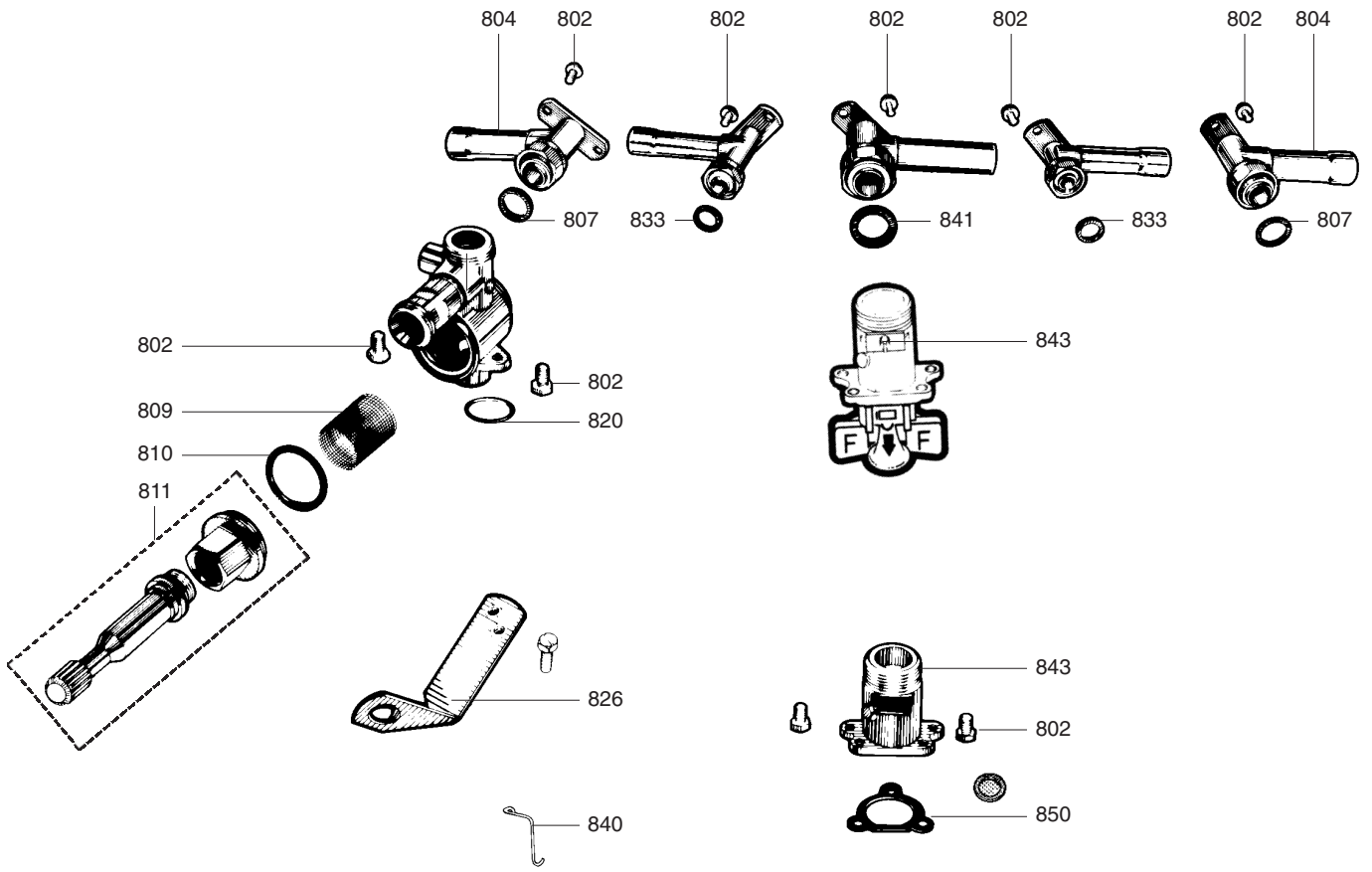

Rep.	Désignation	Référence	Type	2-18		2-22		1-18		TIG 16		1-22		TIG 20		2-20		1-20		TIG 20		RS		BF		30		VE			
				CF	VMC	CF	VMC	CF	CF	CF	CF									CF	CF	CF	CF	CF	CF	CF	CF	CF	CF	de	à
<b>0800</b>	<b>BARRETTE DE ROBINETTERIE</b>																														
0802	VIS M 6-10	60031527-03		•	•	•	•	•	•	•	•	•	•	•	•	•	•	•	•	•	•	•	•	•	•	•	•				
0807	JOINT PLAT D: 24-18.2-1.5	60061855-01		•	•	•	•	•	•	•	•	•	•	•	•	•	•	•	•	•	•	•	•	•	•	•	•				
0809	FILTRE	60025261		•	•	•	•	•	•	•	•	•	•	•	•	•	•	•	•	•	•	•	•	•	•	•	•				
0810	JOINT PLAT D: 38-32.2-1.5	60061857-23		•	•	•	•	•	•	•	•	•	•	•	•	•	•	•	•	•	•	•	•	•	•	•	•				
0811	TETE DE ROBINET ENS	60031040		•	•	•	•	•	•	•	•	•	•	•	•	•	•	•	•	•	•	•	•	•	•	•	•				
0820	JOINT TORIQUE D: 13.6-2.7	60024164-18		•	•	•	•	•	•	•	•	•	•	•	•	•	•	•	•	•	•	•	•	•	•	•	•				
0821	VIS A TETON M5	60017908		•	•	•	•	•	•	•	•	•	•	•	•	•	•	•	•	•	•	•	•	•	•	•	•				
0822	SOUPAPE DE SECURITE (Pochette)	60100702-30		•	•	•	•	•	•	•	•	•	•	•	•	•	•	•	•	•	•	•	•	•	•	•	•				
0823	SOUPAPE DE SECURITE 3 BARS	61020933		•	•	•	•	•	•	•	•	•	•	•	•	•	•	•	•	•	•	•	•	•	•	•	•				
0833	JOINT PLAT D: 18.4-12.2-1.5	60061855-14		•	•	•	•					•																			
0840	CROCHET	60031784																													
0841	JOINT PLAT D: 29.6-22-1.5	60022834-14		•	•	•	•	•	•	•	•	•	•	•	•	•	•	•	•	•	•	•	•	•	•	•	•				
0843	ROBINET GAZ	60027032		•	•	•	•	•	•	•	•	•	•	•	•	•	•	•	•	•	•	•	•	•	•	•	•				
	ROBINET GAZ	60045804																													
0850	JOINT DE FORME (/Robinet gaz)	60019119																													
0852	VIS M 6-12	60000101-13																													

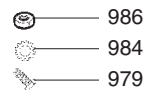
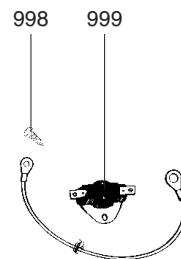
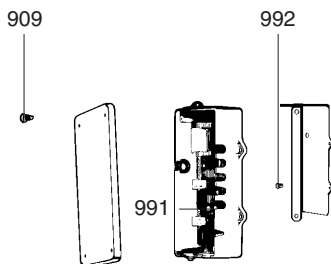
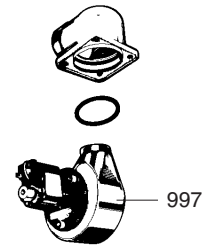
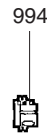
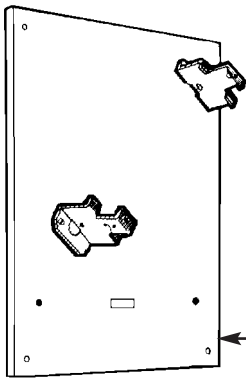
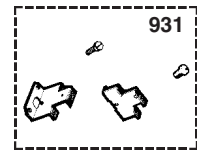
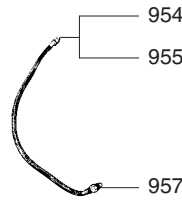
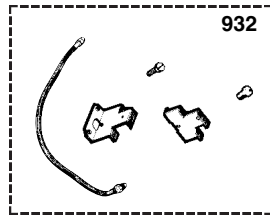
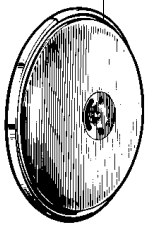
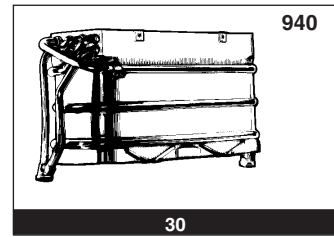
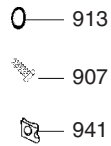
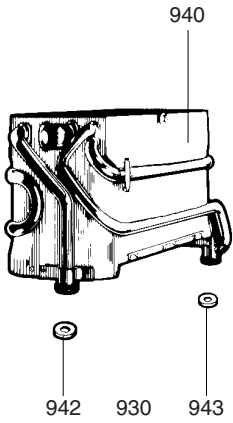
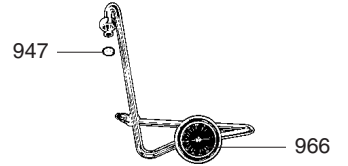
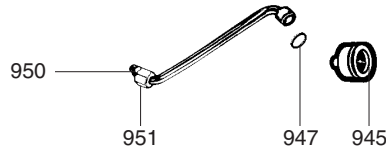
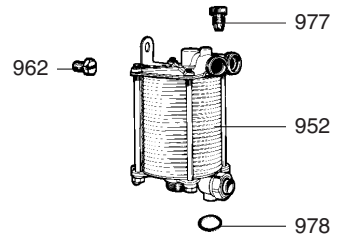
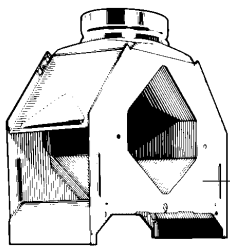



Rep.	Désignation	Référence	Type	2-18		2-22		1-18		TIG 16		1-22		TIG 20		1-20		TIG 20		RS		BF		30		VE		
				CF	VMC	CF	VMC	CF	CF	CF	CF									CF	CF	CF	CF	CF	FF	de	à	
				Date																								
<b>0900</b>	<b>CHASSIS</b>																											
0907	VIS M 6-10	60031527-03		•	•	•	•	•	•	•	•	•	•	•	•	•	•	•	•	•	•	•	•	•	•	•	•	•
0909	VIS A TOLE D: 3.56-16	60045654																										
0913	RONDELLE D: 12-6.2-1.2	60007059-03		•	•	•	•	•	•	•	•	•	•	•	•	•	•	•	•	•	•	•	•	•	•	•	•	•
0929	ANTIREFOULEUR	60034633-06		•																								
0930	VASE D'EXPANSION	60056676-06		•	•	•	•	•	•	•	•	•	•	•	•	•	•	•	•	•	•	•	•	•	•	•	•	•
0931	SUPPORT DE VESPI (Pochette)	60081014																										
0932	EQT REMPLACEMENT VESPI	60081067																										
	EQT REMPLACEMENT VESPI	60081068		•	•																							
0940	CORPS DE CHAUFFE	60026881-06																										
	CORPS DE CHAUFFE	60036933-06																										
	CORPS DE CHAUFFE	60044357-06																										
0941	PATTE DE FIXATION	60014066-03		•	•	•	•	•	•	•	•	•	•	•	•	•	•	•	•	•	•	•	•	•	•	•	•	•
0942	JOINT PLAT D: 24-16.2-1.5	60061855-02		•	•	•	•	•	•	•	•	•	•	•	•	•	•	•	•	•	•	•	•	•	•	•	•	•
	JOINT PLAT D: 23.8-14.4-1.5	60061855-18																										
0943	JOINT PLAT D: 24-18.2-1.5	60061855-01		•	•	•	•	•	•	•	•	•	•	•	•	•	•	•	•	•	•	•	•	•	•	•	•	•
	JOINT PLAT D: 29.9-20-1.5	60061856-03																										
0945	MANOMETRE EQUIPE (Pochette)	60081180		•	•	•	•	•	•	•	•	•	•	•	•	•	•	•	•	•	•	•	•	•	•	•	•	•
0947	JOINT PLAT D: 8.5-4.1-1.5	60061852-12		•	•	•	•	•	•	•	•	•	•	•	•	•	•	•	•	•	•	•	•	•	•	•	•	•
0950	BAGUE BICONE D: 6	60022865		•	•	•	•	•	•	•	•	•	•	•	•	•	•	•	•	•	•	•	•	•	•	•	•	•
0951	ECROU H M 10-1	60022864-08		•	•	•	•	•	•	•	•	•	•	•	•	•	•	•	•	•	•	•	•	•	•	•	•	•
0952	ECHANGEUR SANITAIRE 24 C KIT	61001974		•	•	•	•																					
0954	BAGUE BICONE D: 6	60022865																										
0955	VIS RACCORD BICONE	60031269																										
0957	BAGUE BICONE D: 8.2	60003947																										
0958	RACCORD M 3/4 F 1/2	60048257		•	•	•	•																					
0962	VIS HS M 8-16	60031519-03		•	•	•	•																					
0964	TUBE EAU CHAUDE SANIT. EQUIPE	60078766		•	•	•	•																					
0966	THERMOMETRE	60044333		•	•	•	•	•	•	•	•	•	•	•	•	•	•	•	•	•	•	•	•	•	•	•	•	•
0970	JOINT TORIQUE D: 7.2-1.9	60024164-12		•	•	•	•																					
0977	BOUCHON M 10-100	60036342-08		•	•	•	•																					
0978	JOINT TORIQUE D: 16-1.9	60024183-37		•	•	•	•																					
0979	VIS M 4-6	60019197-03		•	•																							
0983	JOINT MOUSSE SIL 7x7 L: 2.5M	60081273-03																										
0984	RONDELLE EVENTAIL D: 4	60028466-03		•	•																							
0985	HUBLLOT (Pochette)	60081047																										
0991	CIRCUIT IMPRIME	60041067																										
0992	VIS M 5-8	60015691-03																										
0994	ALLUMEUR	60046009-10																										
0997	EXTRACTEUR	60037930																										
0998	VIS A TOLE CBLZ D: 3.5-6.5	60031521-03																										
0999	THERMOSTAT 65°C	60023169-10																										
	SECURITE THERMIQUE 60°C	60040049																										
	SECURITE THERMIQUE 125°C	60041317																										

## LISTE DES ABRÉVIATIONS

EC .....	: Eau chaude.
EF .....	: Eau froide.
C .....	: Résistance Céramique (Chauffe normale).
Ca .....	: Résistance Céramique (Chauffe accélérée).
TP .....	: Résistance ThermoPlongeur.
1F .....	: Avec Robinetterie.
2F .....	: Sans Robinetterie.
3F .....	: Avec Robinetterie et une sortie supplémentaire.
AMI .....	: Avec Mélangeur Intégré.
SMI .....	: Sans Mélangeur Intégré.
TYPE .....	: Indique la nature de l'appareil.
PN .....	: Ces références concernent uniquement un appareil à Pression Normale.
BP .....	: Ces références concernent uniquement un appareil à Basse Pression.
PV .....	: Ces références concernent uniquement un appareil à Puissance Variable.
PF .....	: Ces références concernent uniquement un appareil à Puissance Fixe.

## PLAQUE SIGNALÉTIQUE

### NUMÉRO DE SÉRIE

**12 Caractères :** 1 95 065004 - 31

Mois de fabrication : de 1 à 9 → Jan. à Sep., O → Oct., N → Nov., D → Dec.	1	95	065004	-	31	Indice technique de l'appareil
						Code séquentiel
						Année de fabrication

**20 Caractères :** 3675007 XX 2 07 070 00315

Code appareil	3675007	XX	2	07	070	00315	Code séquentiel
Millénium de fabrication							Jour de fabrication
							Année de fabrication

**21 Caractères :** 3675007 XX 07 070 0000315

Code appareil	3675007	XX	07	070	0000315	Code séquentiel
						Jour de fabrication
						Année de fabrication

Les renseignements portés sur les tarifs et documentations commerciales ou techniques, les schémas et côtes d'encadrements sont donnés à titre indicatif et valables à un instant donné. Le CONSTRUCTEUR se réserve le droit d'apporter toutes modifications de présentation, de forme, de dimension, de conception ou matière à ses produits.