

SPARE PARTS EXPLODED VIEW GAS WALL BOILERS

Model

NECTRA TOP

R8202223-07 - 22/03/2012

1	400243531	NECTRA TOP 3.14 CF NAT	09/00	10/02
2	400243536	NECTRA TOP 3.14 VMC NAT	12/00	10/02
3	400243631	NECTRA TOP 3.18 CF NAT	11/99	10/02
4	400223731	NECTRA TOP 2.23 CF NAT	09/98	01/02
4	400223721	NECTRA TOP 2.23 CF B/P	09/98	09/01
5	400223736	NECTRA TOP 2.23 VMC NAT	09/98	03/02
5	400223726	NECTRA TOP 2.23 VMC B/P
6	400223737	NECTRA TOP 2.23 FF NAT	09/98	11/01
6	400223727	NECTRA TOP 2.23 FF B/P	09/98	11/01
7	400243731	NECTRA TOP 3.23 CF NAT	06/99	03/02
8	400243736	NECTRA TOP 3.23 VMC NAT	07/99	10/01
9	400243737	NECTRA TOP 3.23 FF NAT	07/99	03/02
10	300223731	NECTRA C 2.23 CF NAT	12/00	01/02
10	300223721	NECTRA C 2.23 CF B/P
11	200006778036	NECTRA C 2.23 VMC NAT	10/00	12/011
11	200006778026	NECTRA C 2.23 VMC B/P
12	300223737	NECTRA C 2.23 FF NAT	01/01	01/02
12	300223727	NECTRA C 2.23 FF B/P
13	400223831	NECTRA 2.28 CF NAT	09/98	12/01
13	400223821	NECTRA 2.28 CF B/P
14	400223837	NECTRA 2.28 FF NAT	10/98	02/02
14	400223827	NECTRA 2.28 FF B/P

Col	Reference	Model type	Begin	End
-----	-----------	------------	-------	-----

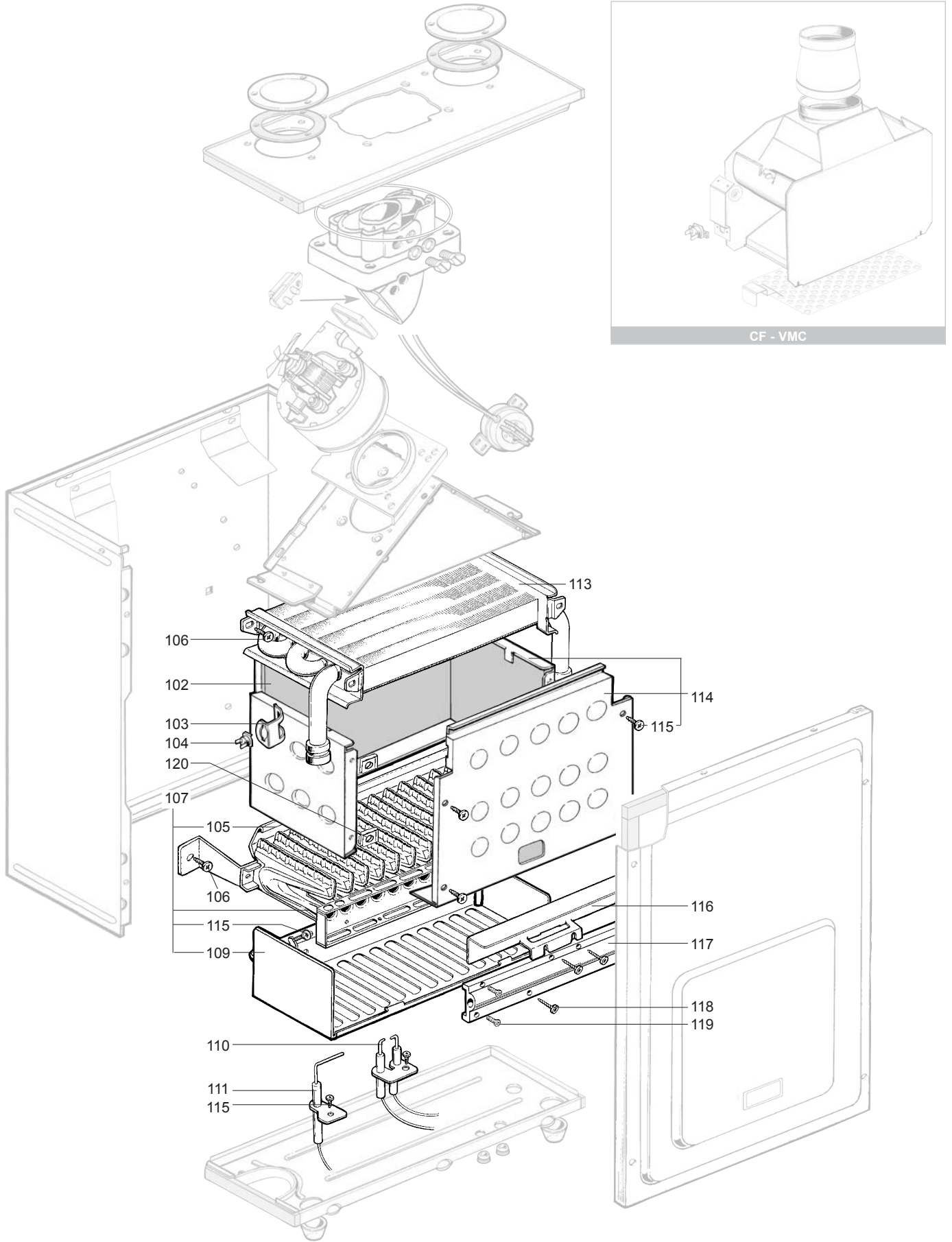

☺	Description	Manf. Pt. N	Type	<div style="display: flex; justify-content: space-between; font-size: 8px; text-align: center;"> NECTRA TOP 314 CF NECTRA TOP 314 MMC NECTRA TOP 318 CF NECTRA TOP 223 CF NECTRA TOP 223 MMC NECTRA TOP 223 FF NECTRA TOP 323 CF NECTRA TOP 323 MMC NECTRA C 223 CF NECTRA C 223 FF NECTRA C 223 MMC NECTRA TOP 228 CF NECTRA TOP 228 FF </div>																		31
				1	2	3	4	5	6	7	8	9	10	11	12	13	14	15	16	17	18	
0100	BURNER ASSEMBLY																					
0102	COMBUSTION CHAMBER LINING KIT	60081722		•	•	•	•	•	•	•	•	•	•	•	•	•	•	•	•			
0103	CLIP	61010050		•	•	•	•	•	•	•	•	•	•	•	•	•	•	•	•			
0104	OVERHEAT THERMOSTAT 105C	61010191		•	•	•	•	•	•	•	•	•	•	•	•	•	•	•	•			
	OVERHEAT THERMOSTAT 100C	61010572						•		•			•		•			•				
0105	CROSS LIGHTING STRIP	61002811						•		•			•		•			•				
	CROSS LIGHTING STRIP	61010038		•	•	•	•	•	•	•	•	•	•	•	•	•	•	•	•			
0106	TAPPING SCREW CBLX D: 6.3-13	61010648		•	•	•	•	•	•	•	•	•	•	•	•	•	•	•	•			
0107	BURNER HEAD	61010415		•	•	•	•	•	•	•	•	•	•	•	•	•	•	•	•			
	BURNER HEAD	61010753						•		•			•		•			•				
0109	GRILLE	61010223						•		•			•		•			•				
0110	IGNITION ELECTRODE	61002801		•	•	•	•	•	•	•	•	•	•	•	•	•	•	•	•			
	IGNITION ELECTRODE	61015740										•	•	•	•	•	•	•	•			
0111	IONIZATION ELECTRODE	61002802		•	•	•	•	•	•	•	•	•	•	•	•	•	•	•	•			
0113	HEAT EXCHANGER	61010017		•	•	•	•	•	•	•	•	•	•	•	•	•	•	•	•			
	HEAT EXCHANGER	61010754																•	•			
	HEAT EXCHANGER	61011136																	•			
0114	COMBUSTION CHAMBER ASSY	60081721		•	•	•	•	•	•	•	•	•	•	•	•	•	•	•	•			
0115	TAPPING SCREW CBLX D: 4.2-9.5	61010125		•	•	•	•	•	•	•	•	•	•	•	•	•	•	•	•			
0116	DEFLECTOR	61010392						•		•			•		•			•				
	DEFLECTOR	61011642																	•			
0117	MANIFOLD 16 INJ.	61010175	B/P	•	•	•	•	•	•	•	•	•	•	•	•	•	•	•	•			
	MANIFOLD 16 INJ.	61011312	B/P																•			
	MANIFOLD 16 INJ.	61011617	B/P																•			
	MANIFOLD 16 INJ.	61010030	NAT	•	•	•	•	•	•	•	•	•	•	•	•	•	•	•	•			
	MANIFOLD 16 INJ.	61010341	NAT					•		•			•		•			•				
	MANIFOLD 16 INJ.	61011305	NAT																•			
0118	TAPPING SCREW CBLX D: 4.2-25	61010128		•	•	•	•	•	•	•	•	•	•	•	•	•	•	•	•			
0119	SCREW HX M 5-12	61010131		•	•	•	•	•	•	•	•	•	•	•	•	•	•	•	•			
0120	SPIRE CLIP	60057488		•	•	•	•	•	•	•	•	•	•	•	•	•	•	•	•			

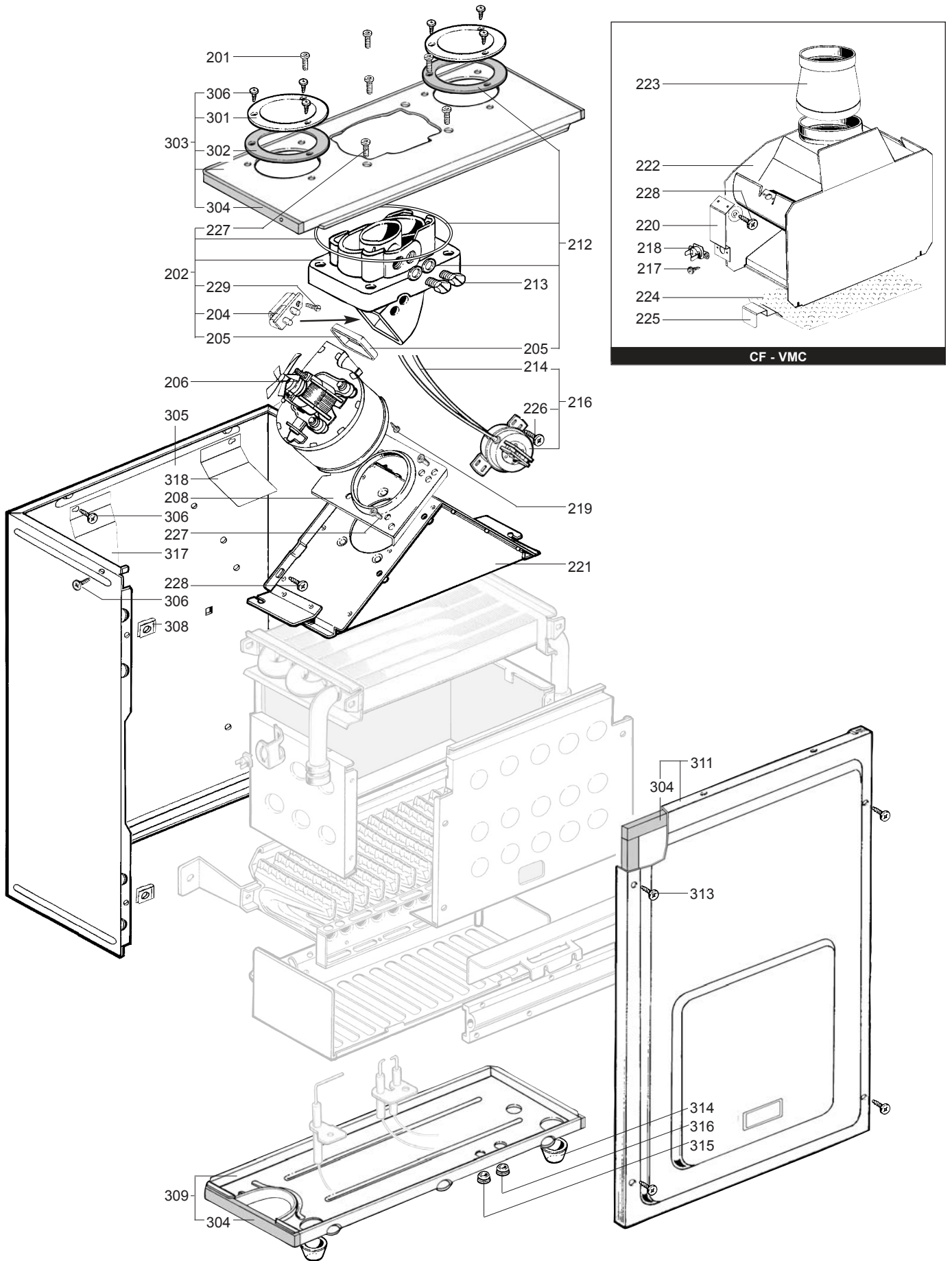

☉⇒	Description	Manf. Pt. N	Type	<div style="display: flex; justify-content: space-between; font-size: 8px; text-align: center;"> NECTRA TOP 314 CF NECTRA TOP 314 VMC NECTRA TOP 318 CF NECTRA TOP 223 CF NECTRA TOP 223 VMC NECTRA TOP 223 FF NECTRA TOP 323 CF NECTRA TOP 323 VMC NECTRA C 223 CF NECTRA C 223 FF NECTRA C 223 VMC NECTRA TOP 228 CF NECTRA TOP 228 FF </div>																	
				1	2	3	4	5	6	7	8	9	10	11	12	13	14	15	16	17	18
0200	FAN ASSEMBLY																				
0201	SCREW H M 6-12	61013098							•		•		•		•						
0202	BEND 45 DEG KIT.	60081726							•		•		•		•						
0204	VENTURI D: 3.7	61010337							•		•		•		•						
0205	GASKET (/Fan assy)	60081729							•		•		•		•						
0206	FAN ASSY	61003011							•		•		•		•						
	FAN ASSY	61010212							•		•		•		•						
0208	FAN PLATE MOUNTING	61010096							•		•		•		•						
0212	COMPLETE GASKETS KIT	60081727							•		•		•		•						
0213	CONNECTION M 14x100	60061665							•		•		•		•						
0214	SILICONE TUBE D: 9x3 L: 1.30M	60081265							•		•		•		•						
0216	AIR PRESSURE SWITCH KIT	60081725							•		•		•		•						
0217	SHEET SCREW CBLX D: 3.5-6.5	61010126		•	•	•	•	•		•		•	•		•						
0218	OVERHEAT THERMOSTAT 72C	61010074				•	•		•		•		•		•						
	OVERHEAT THERMOSTAT 54C	61010358					•		•		•		•		•						
	THERMOSTAT (SAFETY - 70C)	61012479		•																	
	OVERHEAT THERMOSTAT 51.5C	61012480			•																
0219	TAPPING SCREW CBLZ D: 3.5-9.5	60054033						•		•		•		•		•					
0220	SUPPORT BRACKET	61012482			•																
0221	HOOD	61010589						•		•		•		•							
0222	DRAUGHT DIVERTER	61010117		•		•	•		•		•		•		•						
	DRAUGHT DIVERTER	61010354						•		•		•		•							
	DRAUGHT DIVERTER	61011170												•							
0223	FLUE SPIGOT D: 112	61009894		•																	
0224	GRILLE	61011760		•	•																
0225	CLIP	61011761		•	•																
0226	TAPPING SCREW CBLX D: 4.2-9.5	61010125																•			
0227	SCREW HX M 5-12	61010131																•			
0228	TAPPING SCREW CBLX D: 6.3-13	61010648		•	•	•	•	•	•	•	•	•	•	•	•	•	•	•			
0229	SCREW THZ 5-14	61003768							•		•		•		•			•			
0300	SEALED CASE																				
0301	CLOSURE PLATE	61010218							•		•		•		•			•			
0302	GASKET (/Connection)	61010238							•		•		•		•			•			
0303	TOP PANEL BOX KIT	61010590							•		•		•		•			•			
0304	FOAM SEAL 12.5x5 L: 2.5M	60081273							•		•		•		•			•			
0305	CASE	61010106							•		•		•		•			•			
0306	TAPPING SCREW CBLZ D: 4.2-13	60079486							•		•		•		•			•			
0308	SPIRE CLIP	60057488							•		•		•		•			•			
0309	BASE - BOX	61010588							•		•		•		•			•			
0311	CASE COVER	60081851							•		•		•		•			•			
0313	TAPPING SCREW CBLZ D: 4.2-19	61003114							•		•		•		•			•			
0314	GROMMET	61010109							•		•		•		•			•			
0315	GROMMET	60039017							•		•		•		•			•			
0316	GROMMET - DOUBLE	60042707							•		•		•		•			•			
0317	DEFLECTOR	61012601																•			
0318	DEFLECTOR	61012602																•			

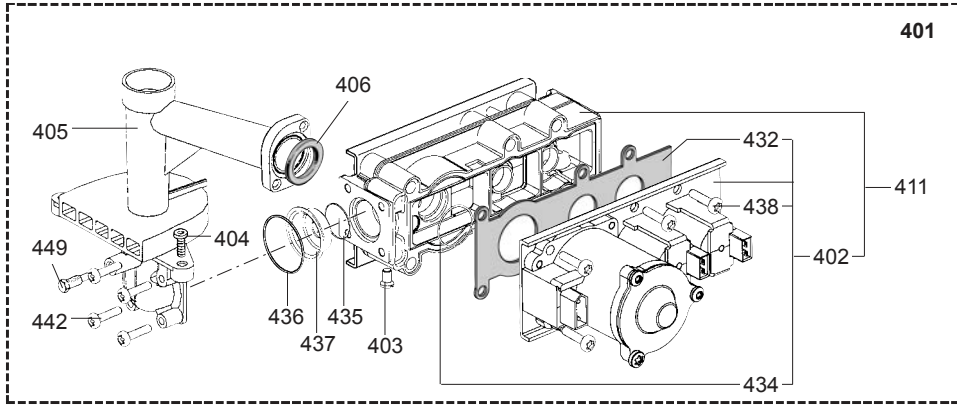

☉⇒	Description	Manf. Pt. N	Type	<div style="display: flex; justify-content: space-between; font-size: 8px; text-align: center;"> NECTRA TOP 3/14 CF NECTRA TOP 3/14 VMC NECTRA TOP 3/18 CF NECTRA TOP 2/23 CF NECTRA TOP 2/23 VMC NECTRA TOP 2/23 FF NECTRA TOP 3/23 CF NECTRA TOP 3/23 VMC NECTRA C 2/23 CF NECTRA C 2/23 FF NECTRA C 2/23 VMC NECTRA TOP 2/28 CF NECTRA TOP 2/28 FF </div>																	
				1	2	3	4	5	6	7	8	9	10	11	12	13	14	15	16	17	18
0400	GAS SECTION																				
0401	GAS VALVE LPG	61014775	B/P				●	●	●	●	●	●	●	●							
	GAS VALVE NAT	61013015	NAT				●	●	●	●	●	●	●	●							
	GAS VALVE NAT	61015664	NAT												●	●					
	GAS VALVE	61017380	NAT			●															
	GAS VALVE	61020775	NAT	●	●																
0402	SOLENOID VALVES KIT LPG	60081860	B/P	●	●	●	●	●	●	●	●	●	●	●	●	●	●	●			
	SOLENOID VALVES KIT NAT	60081859	NAT	●	●	●	●	●	●	●	●	●	●	●	●	●	●	●			
0403	PRESSURE TEST POINT SCREW	60019445		●	●	●	●	●	●	●	●	●	●	●	●	●	●	●			
0404	SCREW HX M 5-12	61010131		●	●	●	●	●	●	●	●	●	●	●	●	●	●	●			
0405	BURNER BASE KIT	60081835		●	●	●	●	●	●	●	●	●	●	●	●	●	●	●			
0406	GASKET (/Manifold)	61010071		●	●	●	●	●	●	●	●	●	●	●	●	●	●	●			
0410	FOAM SEAL 12x7 L: 5M	60081273-04								●											
0411	GAS SECTION LPG	61017399	B/P	●	●	●	●	●	●	●	●	●	●	●	●	●	●	●			
	GAS SECTION NAT	61017398	NAT	●	●	●	●	●	●	●	●	●	●	●	●	●	●	●			
0432	GASKET (/Solenoid valve)	61013018		●	●	●	●	●	●	●	●	●	●	●	●	●	●	●			
0434	O-RING D: 14.1-1.6	60021061-41		●	●	●	●	●	●	●	●	●	●	●	●	●	●	●			
0435	O-RING D: 17.1-1.6	60021061-42		●	●	●	●	●	●	●	●	●	●	●	●	●	●	●			
0436	O-RING D: 22-2.6	60021061-40		●	●	●	●	●	●	●	●	●	●	●	●	●	●	●			
0437	RESTRICTOR D: 6.7	61013016-01					●	●	●	●	●	●	●	●							
	CESTRICTOR D: 3.1	61013016-03	B/P			●															
	RESTRICTOR D: 2.6	61013016-12	B/P	●	●																
	RESTRICTOR D: 4.6	61013016-04	NAT			●															
	RESTRICTOR D: 3.8	61013016-11	NAT	●	●																
0438	SCREW CLXS M 5-45	61014414		●	●	●	●	●	●	●	●	●	●	●	●	●	●	●			
0442	SCREW CBLXS M 4-20	61014415		●	●	●	●	●	●	●	●	●	●	●	●	●	●	●			
0449	PRESSURE TEST POINT SCREW	61016378		●	●	●	●	●	●	●	●	●	●	●	●	●	●	●			

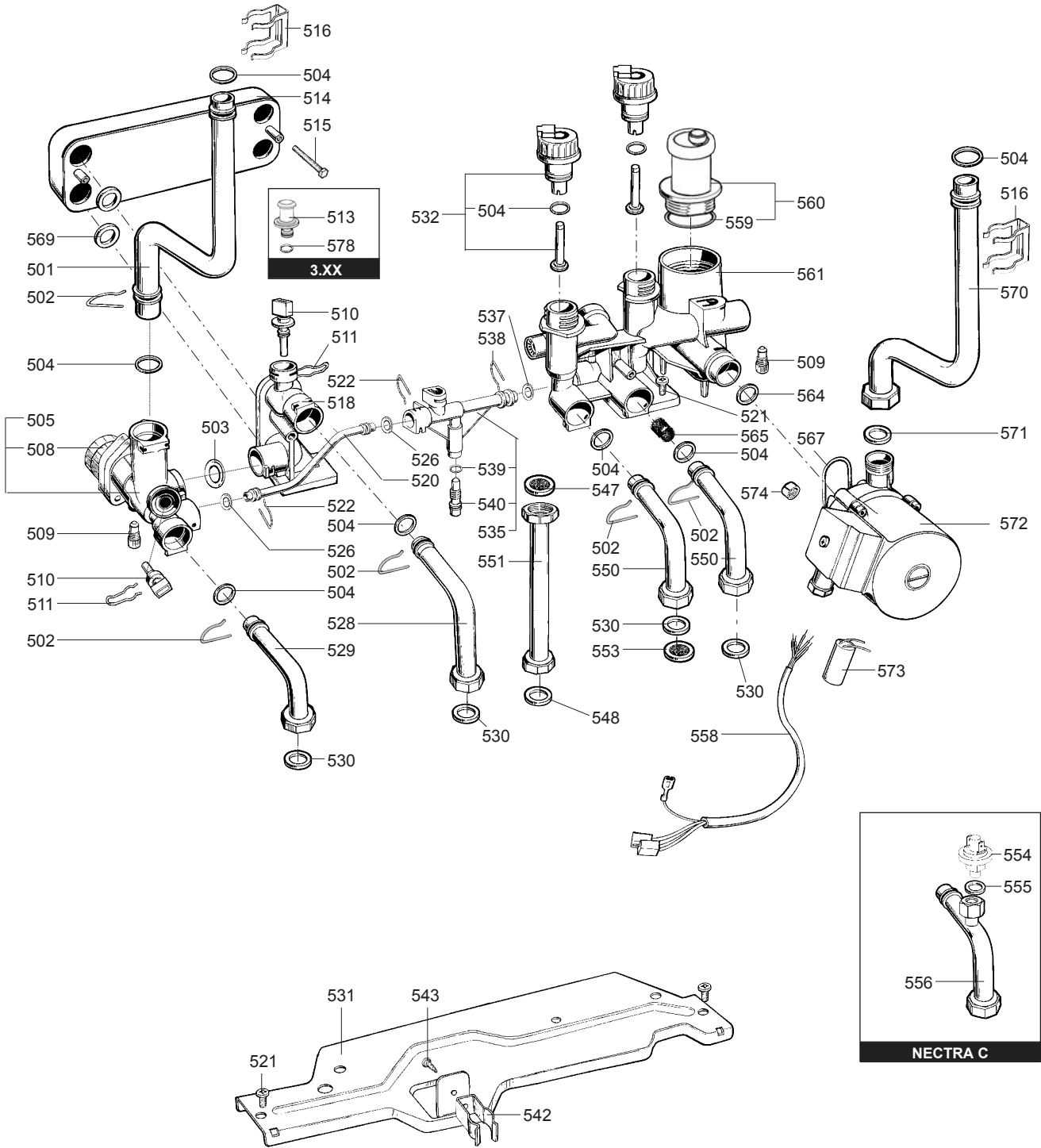
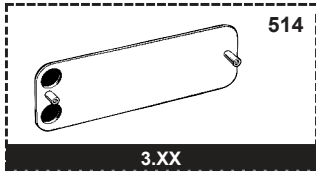

☉⇒	Description	Manf. Pt. N	Type	<div style="display: flex; justify-content: space-between; font-size: small;"> NECTRA TOP 3/14 CF NECTRA TOP 3/14 VMC NECTRA TOP 3/18 CF NECTRA TOP 2/23 CF NECTRA TOP 2/23 VMC NECTRA TOP 2/23 FF NECTRA TOP 3/23 CF NECTRA TOP 3/23 VMC NECTRA C 2/23 CF NECTRA C 2/23 FF NECTRA C 2/23 VMC NECTRA TOP 2/28 CF NECTRA TOP 2/28 FF </div>																	
				1	2	3	4	5	6	7	8	9	10	11	12	13	14	15	16	17	18
0500	HYDRAULIC BLOCK																				
0501	TUBE-EXCHAN TO 3-WAY VALVE	61010333		•	•	•	•	•	•	•	•	•	•	•	•	•	•	•			
0502	CLIP	61010012		•	•	•	•	•	•	•	•	•	•	•	•	•	•	•			
0503	O-RING D: 18.4-2.7	60024164-22		•	•	•	•	•	•	•	•	•	•	•	•	•	•	•			
0504	O-RING D: 17-4	60024164-51		•	•	•	•	•	•	•	•	•	•	•	•	•	•	•			
0505	THREE-WAY VALVE	61010000		•	•	•	•	•	•	•	•	•	•	•	•	•	•	•			
0508	MOTOR - THREE-WAY VALVE	60081953		•	•	•	•	•	•	•	•	•	•	•	•	•	•	•			
0509	DRAIN SCREW ASSY	60081028		•	•	•	•	•	•	•	•	•	•	•	•	•	•	•			
0510	THERMISTOR TEMP. SENSOR	61000733		•	•	•	•	•	•	•	•	•	•	•	•	•	•	•			
0511	TEMPERATURE SENSOR CLIP	61002083		•	•	•	•	•	•	•	•	•	•	•	•	•	•	•			
0513	PLUG	61010485		•	•	•	•	•	•	•	•	•	•	•	•	•	•	•			
0514	SHUNT PLATE	61010611		•	•	•	•	•	•	•	•	•	•	•	•	•	•	•			
	WATER / WATER HEAT EXCHANGER 14	61011164					•	•	•	•	•	•	•	•	•	•	•	•			
0515	SCREW CBLX M 5-40	61010129		•	•	•	•	•	•	•	•	•	•	•	•	•	•	•			
0516	CLIP	61010609		•	•	•	•	•	•	•	•	•	•	•	•	•	•	•			
0518	LEFT HAND HYDRAULIC BLOCK	61010003		•	•	•	•	•	•	•	•	•	•	•	•	•	•	•			
0520	BYPASS TUBE	61010044		•	•	•	•	•	•	•	•	•	•	•	•	•	•	•			
0521	TAPPING SCREW CBLX D: 6.3-19	61010127		•	•	•	•	•	•	•	•	•	•	•	•	•	•	•			
0522	CLIP	61010005		•	•	•	•	•	•	•	•	•	•	•	•	•	•	•			
0526	O-RING D: 8.9-2.7	61009834-14		•	•	•	•	•	•	•	•	•	•	•	•	•	•	•			
0528	HOT WATER BEND	61010056		•	•	•	•	•	•	•	•	•	•	•	•	•	•	•			
0529	HEATING FLOW BEND	61010057		•	•	•	•	•	•	•	•	•	•	•	•	•	•	•			
0530	SHEET GASKET D: 24-17-1.5	60061855-19		•	•	•	•	•	•	•	•	•	•	•	•	•	•	•			
0531	HYDRAULIC PLATE	61010042		•	•	•	•	•	•	•	•	•	•	•	•	•	•	•			
0532	WATER THROTTLE	60081471		•	•	•	•	•	•	•	•	•	•	•	•	•	•	•			
0535	BYPASS BODY	61016387		•	•	•	•	•	•	•	•	•	•	•	•	•	•	•			
0537	O-RING D: 13.6-2.7	60024164-18		•	•	•	•	•	•	•	•	•	•	•	•	•	•	•			
0538	CLIP	61010112		•	•	•	•	•	•	•	•	•	•	•	•	•	•	•			
0539	O-RING D: 1.9-8	61009833-34		•	•	•	•	•	•	•	•	•	•	•	•	•	•	•			
0540	ADJUSTING SCREW OF BY-PASS	61010111		•	•	•	•	•	•	•	•	•	•	•	•	•	•	•			
0542	CLIP	60079845		•	•	•	•	•	•	•	•	•	•	•	•	•	•	•			
0543	TAPPING SCREW CBLX D: 4.2-9.5	61010125		•	•	•	•	•	•	•	•	•	•	•	•	•	•	•			
0547	GAS FILTER	60037309		•	•	•	•	•	•	•	•	•	•	•	•	•	•	•			
0548	SHEET GASKET D: 24-18.2-1.5	60022835-01		•	•	•	•	•	•	•	•	•	•	•	•	•	•	•			
0550	BEND RETURN	61010055		•	•	•	•	•	•	•	•	•	•	•	•	•	•	•			
0551	GAS TUBE	61010040		•	•	•	•	•	•	•	•	•	•	•	•	•	•	•			
0553	WATER FILTER	61007727				•	•	•			•	•	•	•	•	•	•	•			
0554	PRESSURE SENSOR 0.8b	61002720									•	•	•	•	•	•	•	•			
0555	SHEET TASKET D: 15-8.5-1.5	60030867									•	•	•	•	•	•	•	•			
0556	HEATING RETURN TUBE	61015735									•	•	•	•	•	•	•	•			
0558	PUMP LEAD (2 SPEEDS)	61004115		•	•	•	•	•	•	•	•	•	•	•	•	•	•	•			
0559	O-RING D: 45-3.5	61009833-46		•	•	•	•	•	•	•	•	•	•	•	•	•	•	•			
0560	AIR SEPARATOR HEAD ASSEMBLY	61002653		•	•	•	•	•	•	•	•	•	•	•	•	•	•	•			
0561	RIGHT HAND HYDRAULIC BLOCK	61010167		•	•	•	•	•	•	•	•	•	•	•	•	•	•	•			
0564	O-RING D: 24.6-3.6	61009834-30		•	•	•	•	•	•	•	•	•	•	•	•	•	•	•			
0565	HEATING FILTER	61305560		•	•	•	•	•	•	•	•	•	•	•	•	•	•	•			
0567	CLIP	60030898-03		•	•	•	•	•	•	•	•	•	•	•	•	•	•	•			
0569	EXCHANGER GASKET	65104334		•	•	•	•	•	•	•	•	•	•	•	•	•	•	•			
0570	HEATING RETURN TUBE	61010043		•	•	•	•	•	•	•	•	•	•	•	•	•	•	•			
0571	O-RING D: 16-1.9	61009833-37		•	•	•	•	•	•	•	•	•	•	•	•	•	•	•			
0572	PUMP UP 15/50 230V	61010612		•	•	•	•	•	•	•	•	•	•	•	•	•	•	•			
0573	CAPACITOR	61000652-10		•	•	•	•	•	•	•	•	•	•	•	•	•	•	•			
0574	PLUG M 10-100	60015709		•	•	•	•	•	•	•	•	•	•	•	•	•	•	•			
0578	O-RING D: 5.7-1.9	60024164-10		•	•	•			•	•	•										

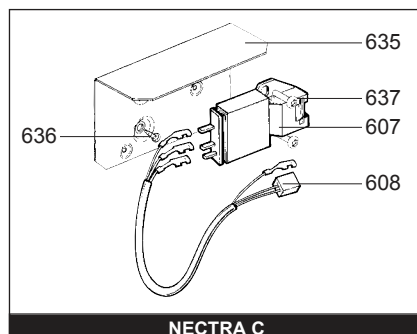
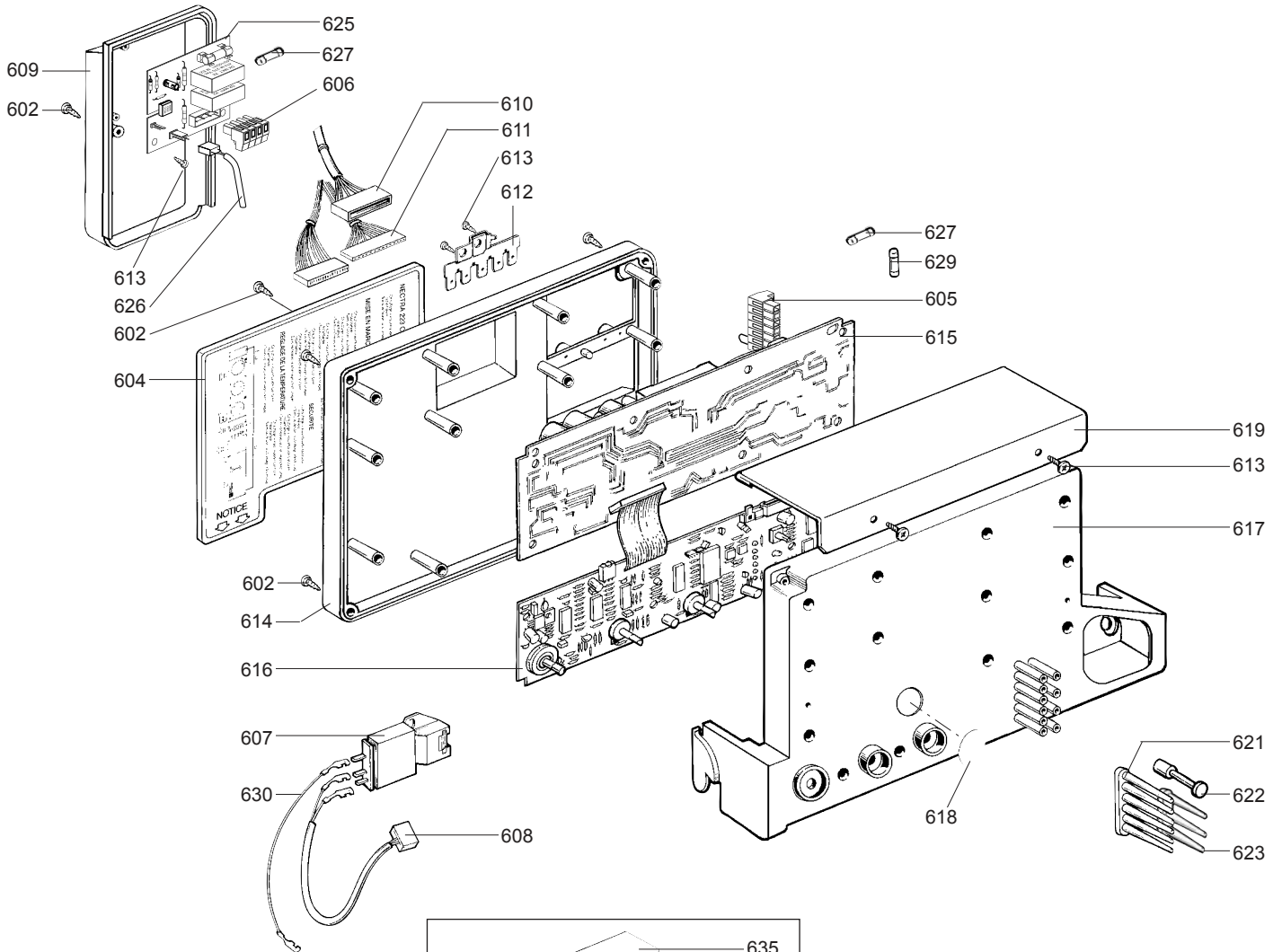
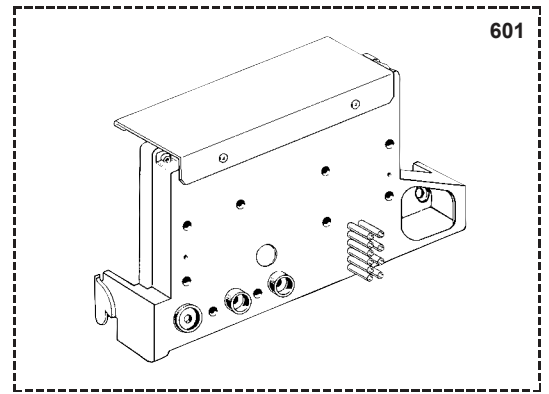

NECTRA C

☉⇒	Description	Manf. Pt. N	Type	<div style="display: flex; justify-content: space-between; font-size: 8px; text-align: center;"> NECTRA TOP 314 CF NECTRA TOP 314 VMC NECTRA TOP 318 CF NECTRA TOP 223 CF NECTRA TOP 223 VMC NECTRA TOP 223 FF NECTRA TOP 323 CF NECTRA TOP 323 VMC NECTRA C 223 CF NECTRA C 223 FF NECTRA C 228 VMC NECTRA TOP 228 CF NECTRA TOP 228 FF </div>																	
				1	2	3	4	5	6	7	8	9	10	11	12	13	14	15	16	17	18
0600	ELECTRICAL BOX																				
0601	ELECTRICAL BOX	61016851										•	•	•							
	ELECTRICAL BOX	61017548				•	•	•						•	•						
	ELECTRICAL BOX	61018982		•	•	•			•	•	•										
0602	SCREW FX90 L:16	61020510		•	•	•	•	•	•	•	•	•	•	•	•	•	•	•			
0604	INSTRUCTIONS HOLDER	61010330				•	•	•				•	•	•	•	•					
	INSTRUCTIONS HOLDER	61010560		•	•	•			•	•	•										
0605	CONNECTOR	61010349		•	•	•	•	•	•	•	•	•	•	•	•	•	•	•			
0606	CONNECTOR	61011046		•	•	•			•	•	•	•	•	•	•	•	•	•			
0607	IGNITER	61002105-20		•	•	•	•	•	•	•	•	•	•	•	•	•	•	•			
0608	IGNITOR CABLE	61010151		•	•	•	•	•	•	•	•			•	•						
	IGNITOR CABLE	61015739										•	•	•	•	•	•	•			
0609	CONNECTOR COVER	61010014		•	•	•	•	•	•	•	•	•	•	•	•	•	•	•			
0610	FAN CABLE	61010332						•			•			•			•	•			
0611	WIRE ASSEMBLY	61014423				•									•						
	WIRE ASSEMBLY	61015012						•								•					
	WIRE ASSEMBLY	61015013					•														
	WIRE ASSEMBLY	61015736										•	•								
	WIRE ASSEMBLY	61015737											•								
	WIRE ASSEMBLY	61020085		•		•			•												
	WIRE ASSEMBLY	61020086									•										
	WIRE ASSEMBLY	61020087			•					•											
0612	CONNECTION STRIP	61010152		•	•	•	•	•	•	•	•	•	•	•	•	•	•	•			
0613	TAPPING SCREW TCBL D:4 L:10	61020509		•	•	•	•	•	•	•	•	•	•	•	•	•	•	•			
0614	ELECTRICAL BOX COVER	61010007		•	•	•	•	•	•	•	•	•	•	•	•	•	•	•			
0615	PRINTED CIRCUIT BOARD OF POWER	61010592		•	•	•	•	•	•	•	•	•			•	•					
	PRINTED CIRCUIT BOARD	61016602										•	•	•							
0616	PRINTED CIRCUIT BOARD OF REGU.	61012951				•	•	•						•	•						
	PRINTED CIRCUIT BOARD	61016603										•	•	•							
	PRINTED CIRCUIT BOARD OF REGU.	61018940		•	•	•			•	•	•										
0617	ELECTRIC BOX PLATE	61010006		•	•	•	•	•	•	•	•	•	•	•	•	•	•	•			
0618	PLUG	61011316		•	•	•	•	•	•	•	•	•	•	•	•	•	•	•			
0619	PROTECTIVE PLATE	61010239		•	•	•	•	•	•	•	•	•	•	•	•	•	•	•			
0621	TRANSMITTER OF LEDS - TEMPORA.	61010010		•	•	•	•	•	•	•	•	•	•	•	•	•	•	•			
0622	IGNITION PUSH ROD	61010072		•	•	•	•	•	•	•	•	•	•	•	•	•	•	•			
0623	TRANSMITTER OF LEDS - ON/OFF	61010011		•	•	•	•	•	•	•	•	•	•	•	•	•	•	•			
0625	PRINTED CIRCUIT BOARD	61010916		•	•	•			•	•	•										
0626	PRINTED CIRCUIT BOARD LEAD	61014837		•	•	•			•	•	•										
0627	FUSE 250V 2A - TEMPORIZED	61003456		•	•	•	•	•	•	•	•	•	•	•	•	•	•	•			
0629	FUSE 250V 1.25A - TEMPORIZED	61003635		•	•	•	•	•	•	•	•	•	•	•	•	•	•	•			
0630	EARTH WIRE	61011585		•	•	•	•	•	•	•	•			•	•						
0635	IGNITION SUPPORT	61015738										•	•	•							
0636	TAPPING SCREW D: 3.5-9.5	61015329										•	•	•							
0637	SELF TAPPING SCREW M 4-8	60044851										•	•	•							

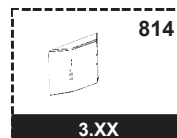
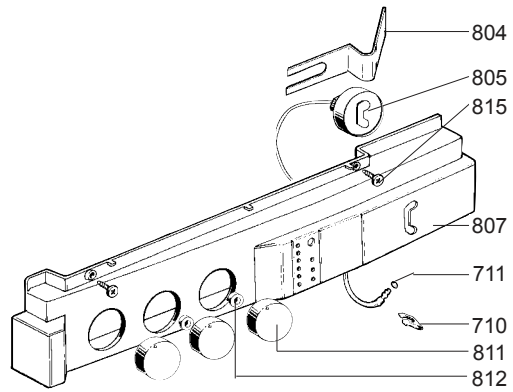
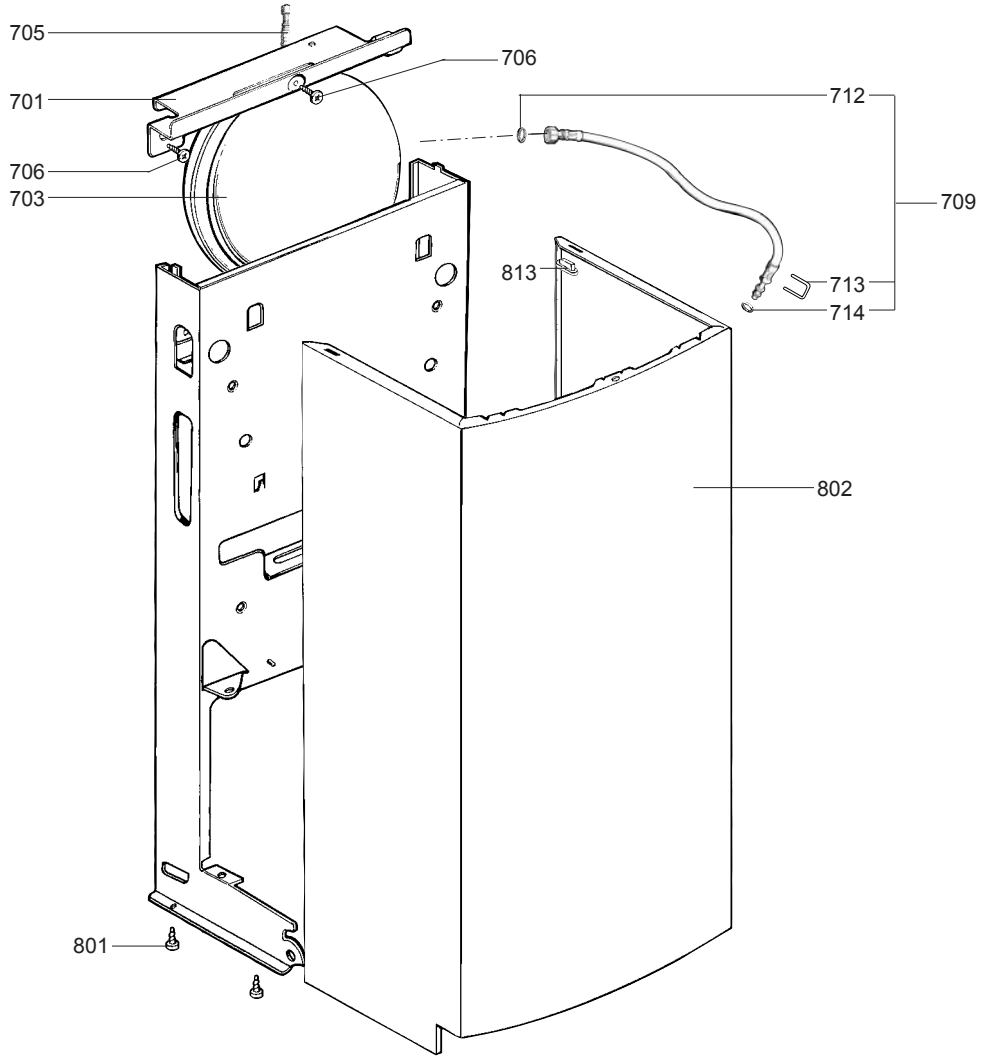

☉⇒	Description	Manf. Pt. N	Type	<div style="display: flex; justify-content: space-between; font-size: small;"> NECTRA TOP 314 CF NECTRA TOP 314 VMC NECTRA TOP 318 CF NECTRA TOP 223 CF NECTRA TOP 223 VMC NECTRA TOP 223 FF NECTRA TOP 323 CF NECTRA TOP 323 VMC NECTRA C 223 CF NECTRA C 223 VMC NECTRA C 223 FF NECTRA TOP 228 CF NECTRA TOP 228 FF </div>																	
				1	2	3	4	5	6	7	8	9	10	11	12	13	14	15	16	17	18
0700	CHASSIS																				
0701	TOP STAY PLATE	61010029		•	•	•	•	•	•	•	•	•	•	•	•						
0703	EXPANSION VESSEL	60056676-06		•	•	•	•	•	•	•	•	•	•	•	•						
0705	EXPANSION VESSEL AIR HOSE	61010170		•	•	•	•	•	•	•	•	•	•	•	•						
0706	TAPPING SCREW CBLX D: 6.3-19	61014516		•	•	•	•	•	•	•	•	•	•	•	•						
0709	FLEXIBLE PIPE KIT	60081824		•	•	•	•	•	•	•	•	•	•	•	•						
0710	CLIP	61002406		•	•	•	•	•	•	•	•	•	•	•	•						
0711	O RING D: 5.7-1.9	61009834-10		•	•	•	•	•	•	•	•	•	•	•	•						
0712	SHEET GASKET D: 12-6-2	61308868		•	•	•	•	•	•	•	•	•	•	•	•						
0713	CLIP	61010005		•	•	•	•	•	•	•	•	•	•	•	•						
0714	O-RING D: 8.9-2.7	61009834-14		•	•	•	•	•	•	•	•	•	•	•	•						
0800	FRONT CASE																				
0801	TAPPING SCREW CBLX D: 4.2-9.5	61010125		•	•	•	•	•	•	•	•	•	•	•	•						
0802	CASE	61010016		•	•	•	•	•	•	•	•	•	•	•	•						
0804	SUPPORT BRACKET	61010095		•	•	•	•	•	•	•	•	•	•	•	•						
0805	PRESSURE GAUGE	61010048		•	•	•	•	•	•	•	•	•	•	•	•						
0807	SERIGRAPHED STRIP (FOR PROG.)	61018703									•	•	•	•							
	SERIGRA. STRIP (WITHOUT PROG.)	61018705									•	•	•	•							
	SERIGRAPHED STRIP (FOR PROG.)	61018711		•	•	•	•	•	•	•				•	•						
	SERIGRA. STRIP (WITHOUT PROG.)	61018713		•	•	•	•	•	•	•				•	•						
0811	BLACK KNOB	61010009		•	•	•	•	•	•	•	•	•	•	•	•						
0812	CENTRING PIECE	61010241		•	•	•	•	•	•	•	•	•	•	•	•						
0813	SPACER	61015797		•	•	•	•	•	•	•	•	•	•	•	•						
0814	HOLE PLATE	61010421		•	•	•		•	•	•	•	•	•	•	•						
0815	SCREW FX90 D: 3.5-16	61010133		•	•	•	•	•	•	•	•	•	•	•	•						

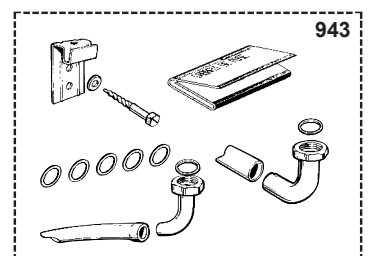
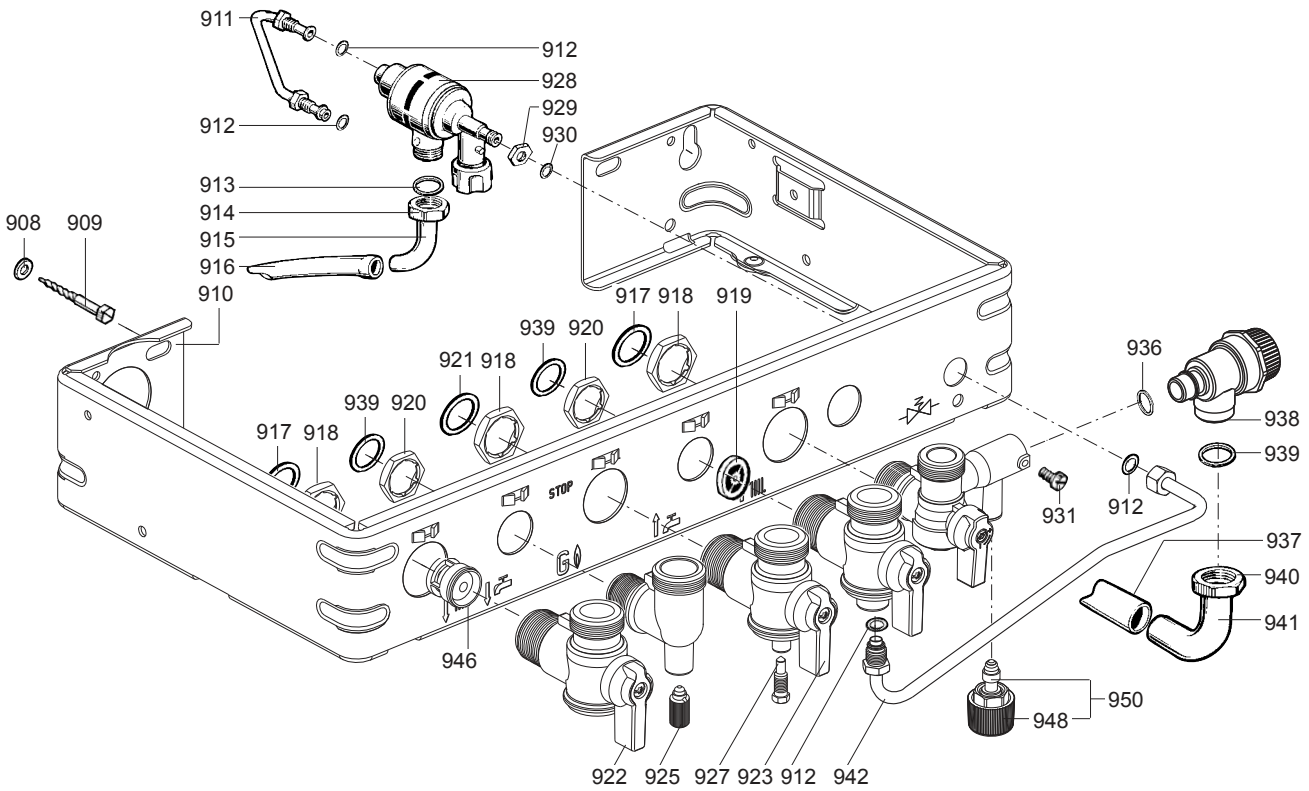
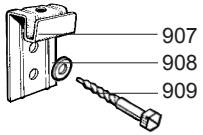
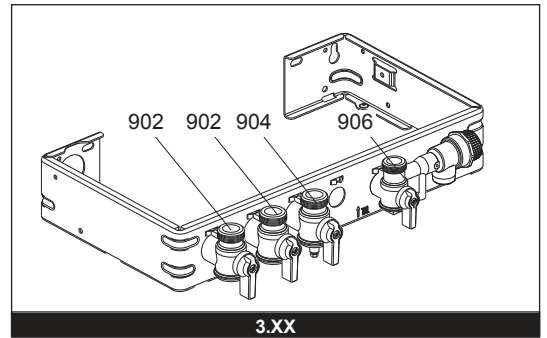
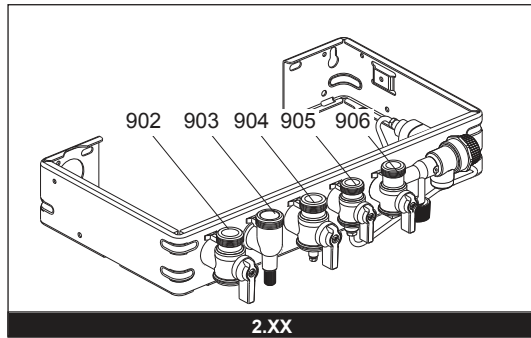

☉⇒	Description	Manf. Pt. N	Type	<div style="display: flex; justify-content: space-between; font-size: small;"> NECTRA TOP 3/4 CF NECTRA TOP 3/4 VMC NECTRA TOP 3/8 CF NECTRA TOP 2/3 CF NECTRA TOP 2/3 VMC NECTRA TOP 2/3 FF NECTRA TOP 3/23 CF NECTRA TOP 3/23 VMC NECTRA C 2/3 CF NECTRA C 2/3 VMC NECTRA TOP 2/3 CF NECTRA TOP 2/3 FF </div>																		31
				1	2	3	4	5	6	7	8	9	10	11	12	13	14	15	16	17	18	
0900	JIG PLATE & PIPE FITTING																					
0902	WATER FLOW SERVICE TAP	61020388		•	•																	
0903	HOT WATER CONNECTION	61020916																				
0904	GAS SERVICE TAP	61020389		•	•	•	•	•	•	•	•	•	•	•	•	•	•	•	•			
0905	COLD WATER TAP	61302612																				
0906	WATER RETURN SERVICE TAP	61302614		•	•	•	•	•	•	•	•	•	•	•	•	•	•	•	•			
0907	WALL HOOK	61002497		•	•	•	•	•	•	•	•	•	•	•	•	•	•	•	•			
0908	WASHER D: 14.2-7.2-1.2	60005369-03		•	•	•	•	•	•	•	•	•	•	•	•	•	•	•	•			
0909	WOOD SCREW	60025617-03		•	•	•	•	•	•	•	•	•	•	•	•	•	•	•	•			
0911	DISCONNECTOR TUBE	61010065																				
0912	O-RING D: 6-1	60024164-41																				
0913	SHEET GASKET D: 14.8-10.3-1.5	60061854-11																				
0914	NUT 3/8» THICK: 11	60020746-20																				
0915	CONNECTING PIPE	60001574																				
0916	TUBE PVC D: 9x12 L: 1M	60081266																				
0917	SHEET GASKET D: 24-17-1.5	60061855-19		•	•	•	•	•	•	•	•	•	•	•	•	•	•	•	•			
0918	LOCK NUT	60031140		•	•	•	•	•	•	•	•	•	•	•	•	•	•	•	•			
0919	FLOW REGULATORE 7L/MIN(DARK GREEN)	61002775-07																				
	FLOW REGULATORE 8L/MIN (WHITE)	61002775-08																				
	FLOW REGULATORE 10L/MIN (BLUE)	61002775-10																				
	FLOW REGULATORE 12L/MIN (RED)	61002775-12																				
	FLOW REGULATORE 14L/MIN (PINK)	61002775-14																				
	FLOW REGULATORE 15L/MIN (PALE GREEN)	61002775-15																				
0920	CONTRODADO H 1/2	60031139																				
0921	SHEET GASKET D: 24-18.2-1.5	60022835-01		•	•	•	•	•	•	•	•	•	•	•	•	•	•	•	•			
0922	HAND LEVER BLACK	61302611		•	•	•	•	•	•	•	•	•	•	•	•	•	•	•	•			
0923	HAND LEVER YELLOW	61302610		•	•	•	•	•	•	•	•	•	•	•	•	•	•	•	•			
0925	DRAIN SCREW ASSY	60081028		•	•	•	•	•	•	•	•	•	•	•	•	•	•	•	•			
0927	PRESSURE TEST POINT SCREW	60019445		•	•	•	•	•	•	•	•	•	•	•	•	•	•	•	•			
	PRESSURE TEST POINT SCREW	61016378		•	•	•	•	•	•	•	•	•	•	•	•	•	•	•	•			
0928	DISCONNECTOR KIT	60081664																				
0929	NUT H M 10-1	60031825-08																				
0930	SHEET GASKET D: 8.5-4.1-1.5	60061852-12																				
0931	GRUB SCREW	60017908		•	•	•	•	•	•	•	•	•	•	•	•	•	•	•	•			
	GRUB SCREW	61304327		•	•	•	•	•	•	•	•	•	•	•	•	•	•	•	•			
0936	O-RING D: 13.6-2.7	61009834-18																				
0937	TUBE PVC D: 13x17 L: 1M	60081266-02		•	•	•	•	•	•	•	•	•	•	•	•	•	•	•	•			
0938	PRESSURE RELIEF VALVE	61020933		•	•	•	•	•	•	•	•	•	•	•	•	•	•	•	•			
0939	WASHER D: 18.4-12.2-1.5	60061855-14		•	•	•	•	•	•	•	•	•	•	•	•	•	•	•	•			
0940	NUT 1/2» THICK: 10	60020747-68		•	•	•	•	•	•	•	•	•	•	•	•	•	•	•	•			
0941	VALVE CONNECTING PIPE	60047727		•	•	•	•	•	•	•	•	•	•	•	•	•	•	•	•			
0942	DISCONNECTOR TUBE	61010064																				
	FILLER NECK	61020885																				
0943	ACCESSORY KIT	61010324																				
0946	NON-RETURN VALVE	61014425		•	•	•																
0948	GREY KNOB	61302613		•	•	•	•	•	•	•	•	•	•	•	•	•	•	•	•			
0950	TAP HEAD	61314798		•	•	•	•	•	•	•	•	•	•	•	•	•	•	•	•			

5000

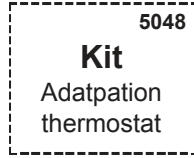
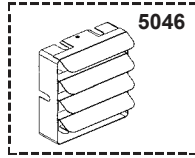
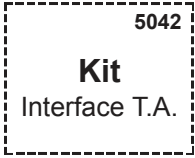
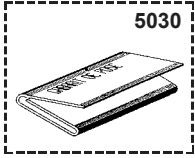
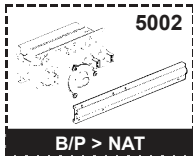
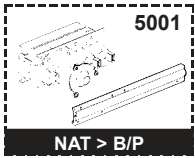

6000

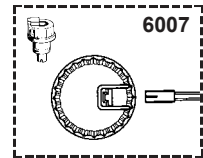
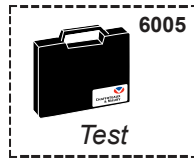
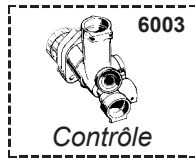
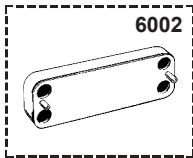
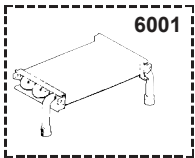

☉⇒	Description	Manf. Pt. N	Type	<div style="display: flex; justify-content: space-between; font-size: small;"> NECTRA TOP 3/14 CF NECTRA TOP 3/14 VMC NECTRA TOP 3/18 CF NECTRA TOP 2/23 CF NECTRA TOP 2/23 VMC NECTRA TOP 2/23 FF NECTRA TOP 3/23 CF NECTRA TOP 3/23 VMC NECTRA C 2/23 CF NECTRA C 2/23 FF NECTRA C 2/23 VMC NECTRA TOP 2/28 CF NECTRA TOP 2/28 FF </div>																	
				1	2	3	4	5	6	7	8	9	10	11	12	13	14	15	16	17	18
5000	ACCESSORIES																				
5001	CONVERSION KIT NAT > LPG	61018430				•															
	CONVERSION KIT NAT > LPG	61018431					•	•	•	•	•	•	•	•							
	CONVERSION KIT NAT > LPG	61018432															•				
	CONVERSION KIT NAT > LPG	61018433																•			
	CONVERSION KIT NAT > LPG	61301725		•	•																
5002	CONVERSION KIT BUT/PROP > NAT	61018426				•															
	CONVERSION KIT BUT/PROP > NAT	61018427					•	•		•	•		•	•							
	CONVERSION KIT BUT/PROP > NAT	61018428							•			•									
	CONVERSION KIT LPG > NAT	61018429																•			
5030	JIG PLATE	61010073		•	•	•	•	•	•	•	•	•	•	•	•	•	•	•			
5041	ANTIFREEZE KIT	61011278		•	•	•	•	•		•	•	•	•	•	•	•	•	•			
	ANTIFREEZE KIT	61011279						•			•			•				•			
5042	INTERFACE SYSTEM - ROOM THERMO	61012505		•	•	•	•	•	•	•	•	•	•	•	•	•	•	•			
5043	KIT NECTRA TOP 2.23>18 CF LPG	61301393	B/P				•														
	KIT NECTRA TOP 2.23>18 VMC LPG	61301394	B/P					•													
	KIT NECTRA TOP 3.23>18 VMC LPG	61301395	B/P								•										
	KIT NECTRA TOP 2.23>18 CF NAT	61301390	NAT				•														
	KIT NECTRA TOP 2.23>18 VMC NAT	61301391	NAT					•													
	KIT NECTRA TOP 3.23>18 VMC NAT	61301392	NAT								•										
5046	DEFLECTOR 30DEG KIT	61014810						•			•			•				•			
5048	THERMOSTAT ADAPTATION KIT	61015000		•	•	•	•	•	•	•	•	•	•	•	•	•	•	•			
6000	MAINTENANCE																				
6001	DESCALING INTERFACE/HEAT EXCHA	61014100		•	•	•	•	•	•	•	•	•	•	•	•	•	•	•			
6002	DESCALING INTERFACE/WATER EXCH	61011075					•	•	•			•	•	•	•	•	•	•			
6003	SIMULATING BOX 3 WAY VALVE	61012597		•	•	•	•	•	•	•	•	•	•	•	•	•	•	•			
6005	TEST SUITCASE-SECURITY SYSTEM	60081881		•	•	•	•	•	•	•	•	•	•	•	•	•	•	•			
	TEST SUITCASE FOR P.C.B.	60081882		•	•	•	•	•	•	•	•	•	•	•	•	•	•	•			
6006	SPANNER	61302650		•			•					•									
6007	STOPPED W/THROT. CONNECTOR KIT	61306970		•				•					•								

LIST OF THE ABBREVIATIONS

HW	: Hot water.
CW	: Cold water.
C	: Ceramic resistance (normal heating).
Ca	: Ceramic resistance (accelerated heating)
TP	: Immersion heater.
1F	: With fittings.
2F	: Without fittings.
3F	: With fittings and another outlet connection.
AMI	: With mixing valve.
SMI	: Without mixing valve.
PUISS	: Power of th appliance.
PN	: Appliance with normal pression.
LP	: Appliance with low pression.
PV	: Appliance with variable power.
PF	: Appliance with fixed power.

IDENTIFICATION PLATE

SERIAL NUMBER

10 Characters :	04 05 125 011	
		Sequential number
		Manufacturing day
		Year of manufacture
11 Characters :	1 95 065004 - 31	
Month of manufacture :		Technical number of the appliance
from 1 to 9 → Jan. to Sep.,		Sequential number
O → Oct., N → Nov.,		Year of manufacture
D → Dec.		
19 Characters :	08 05 0013199 900640031	
Year of manufacture		Product reference
Month of manufacture		Sequential number
20 Characters :	3675007 XX 2 07 070 00315	
Product reference		Sequential number
Millenium of manufacture		Manufacturing day
		Year of manufacture
21 Characters :	3675007 XX 07 070 0000315	
Product reference		Sequential number
Year of manufacture		Manufacturing day

The indications mentioned on the prices, commercial or technical literature and the scheme are written for your guidance and are available at a given time. The CONSTRUCTOR retains the power to modify the presentation, the form, the size, the conception or the material of the products.