

## VENUS3 PLUS

Componenti Struttura Esterna / External structure components / Bauteile Aussenkorpus / Composants structure externe / Componentes estructura externa

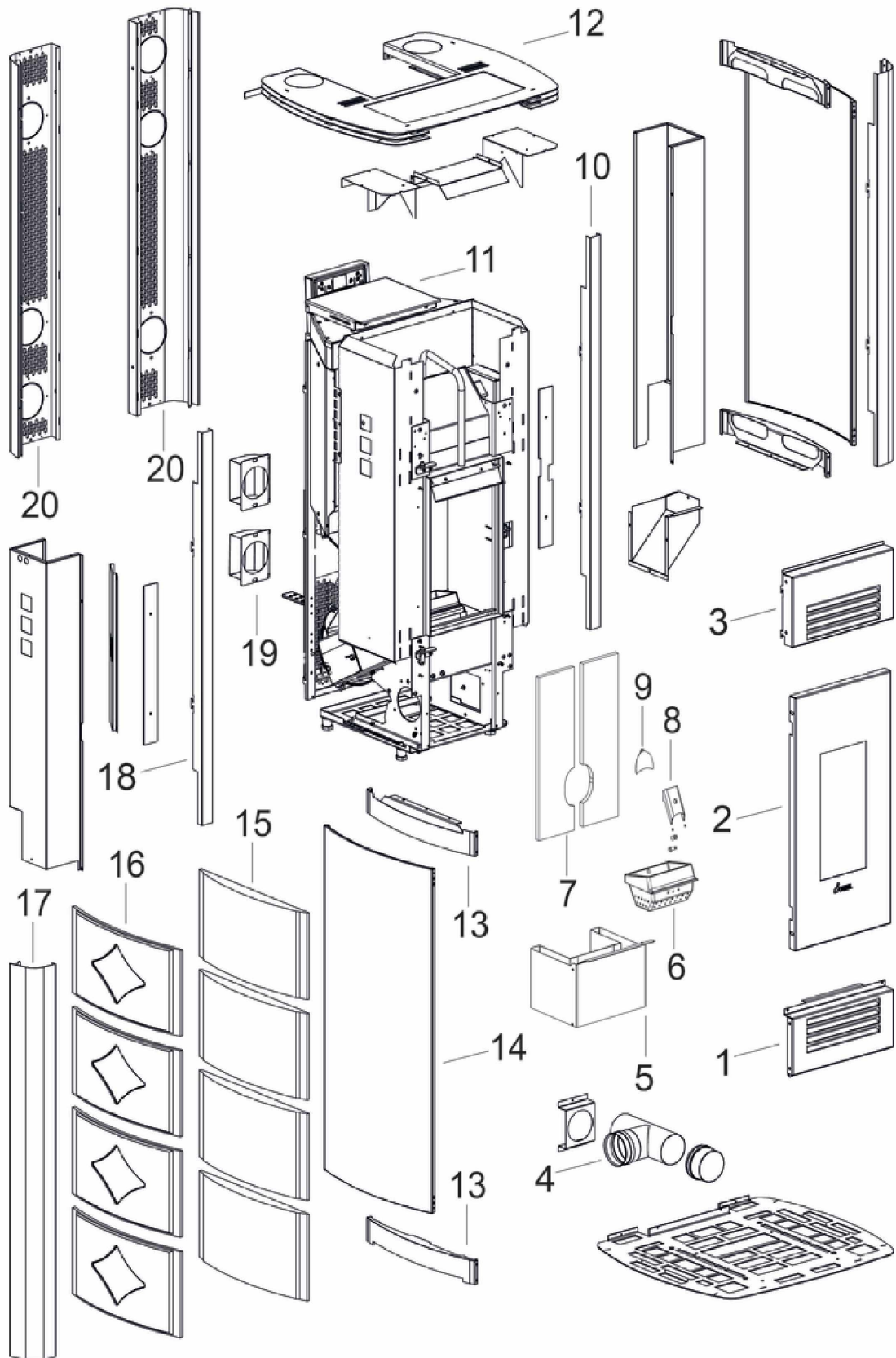

N°	Codice/Code	Descrizioni / Description / Beschreibung / Description / Descripcion	Prezzo (€)
1	4D24014911363	Pannello frontale inferiore / Frontal lower panel / Untere Frontblende / Panneau frontal inferieur / Panel frontal inferior	51.00
2	4D245GP16011	Porta fuoco completa / Complete fire door / Komplette Feuertür / Porte foyer complète / Puerta hogar completa	196.00
2	4D24015841361	Kit decompressione camera di combustione / Pressure relief kit / Bausatz Überdruckablauf Brennkammer / Kit decompression chambre de combustion / Kit decompression cámara de combustión	32.00
3	4D24014912361	Pannello frontale superiore / Frontal upper panel / Obere Frontblende / Panneau frontal superieur / Panel frontal superior	53.00
4	4D160140070	Raccordo a "T" + Guarnizione / T-Union + Gasket / T-Stück + Dichtung / Raccord en "T" + joint / Tubería en te + Junta	51.00
5	4D24014015461	Cassetto cenere / Ash drawer / Aschenkasten / Tiroir à cendres / Cajón ceniza	84.00
6	413008003	Braciere completo in ghisa / Cast iron complete grate / Kompletter Brennertopf aus Gusseisen / Brasero complet en fonte / Brasero completo de arrabio	67.00
6	4D13016602061	Braciere / Grate / Brennschale / Brasero / Brasero	62.00
7	4D115140020	Schiena in Calorite (2pz) / Calorite back (2 Pcs) / Rückwand aus Calorite (2 Stk) / Fond en Calorite (2 Pcs) / Parte trasera de Calorite (2 Pz)	49.00
8	4D242140053	Antiscoppio / Anti-explosion / Bausatz Überdruckablauf Brennkammer / Plaquelette Easy-Start / Anti-explosión	28.00
9	4D2401303101	Deflettore pellet / Pellet deflector / Pellet Leitblech / Deflecteur pellet / Deflector pellet	34.00
10	4D242149013	Profilo laterale / Side profile / Seitenprofil / Profil latéral / Perfil lateral	51.00
11	4D24014020361	Coperchio serbatoio pellet / Pellet hopper cover / Deckel Pelletbehälter / Couvercle réservoir pellet / Tapadera depósito	48.00
11	4D18013016	Guarnizione 155X190 mm / Gasket 155X190 mm / Dichtung 155x190 mm / Joint 155X190 mm / Junta 155X190 mm	34.00
12	4D24014919461	Top Venus 3P / Top / Topplatte / Dessus / Top	164.00
13	4D24014920463	Compensatore Venus 3P / Venus 3P compensator / Abstandhalterung Venus 3P / Compensateur / Compensador Venus 3P	61.00
13	4D24014920463	Compensatore Venus 3P / Venus 3P compensator / Abstandhalterung Venus 3P / Compensateur / Compensador Venus 3P	61.00
14	6913036	Rivestimento metallo Silver / Silver metal cladding / Verkleidung aus Metall Silber / Habillage metal Silver / Revestimiento metal Silver	187.00
14	6913037	Rivestimento metallo Rosso / Red metal cladding / Verkleidung aus Metall Rot / Habillage métal Rouge / Revestimiento metal Rojo	175.00
14	6913038	Rivestimento metallo Avorio / Ivory metal cladding / Verkleidung aus Metall Elfenbein / Habillage métal Ivoire / Revestimiento metal Marfil	187.00
14	6913078	Rivestimento metallo Antracite / Charcoal metal cladding / Verkleidung aus Metall Anthrazit / Habillage métal Antracite / Revestimiento metal Antracita	175.00
14	6915020	Rivestimento completo metallo Light bronze / Complete Light bronze metal cladding / Komplette Verkleidung Metall Light bronze / Habillage complet métal Light Bronze / Revestimiento completo metal Light bronze	208.00
15	4D12513010	Pietra laterale serpentino / Lateral soapstone / Seitliche Stein aus Serpentino / Pierre latérale serpentine / Piedra lateral en Serpentino	124.00
15	4D12513009	Pietra laterale bianca / White lateral stone / Seitliche Stein Weiss / Pierre latérale blanche / Piedra lateral Blanca	-
16	4D12513028	Ceramica laterale rosso / Red side ceramic / Seitliche Keramik Rot / Céramique latérale rouge / Cerámica lateral rojo	108.00
16	4D12513030	Ceramica laterale avorio / Ivory side ceramic / Seitliche Keramik Elfenbein / Céramique latérale ivoire / Cerámica lateral marfil	118.00
16	4D12513032	Ceramica laterale nero brillante / Sparkling black side ceramic / Seitliche Keramik glänzend Schwarz / Céramique latérale noire brillante / Cerámica lateral negro brillante	99.00
17	4D24014904363	Montante anteriore Nero 500° / Front rod black 500° / Vordere Montageleiste Schwarz 500° / Montant antérieur noir 500° / Montante frontal negro 500°	63.00
18	4D242149013	Profilo laterale / Side profile / Seitenprofil / Profil latéral / Perfil lateral	51.00
19	4D24014023363	Diffusore aria calda / Hot air diffuser / Warmluftdiffusor / Diffuseur air chaude / Difusor aire caliente	28.00
20	4D24014913363	Montante posteriore Nero 80° / Rear rod black 80° / Hintere Montageleiste Schwarz 80° / Montant posterior noir 80° / Montante posterior negro 80°	75.00
20	4D24014913363	Montante posteriore Nero 80° / Rear rod black 80° / Hintere Montageleiste Schwarz 80° / Montant posterior noir 80° / Montante posterior negro 80°	75.00

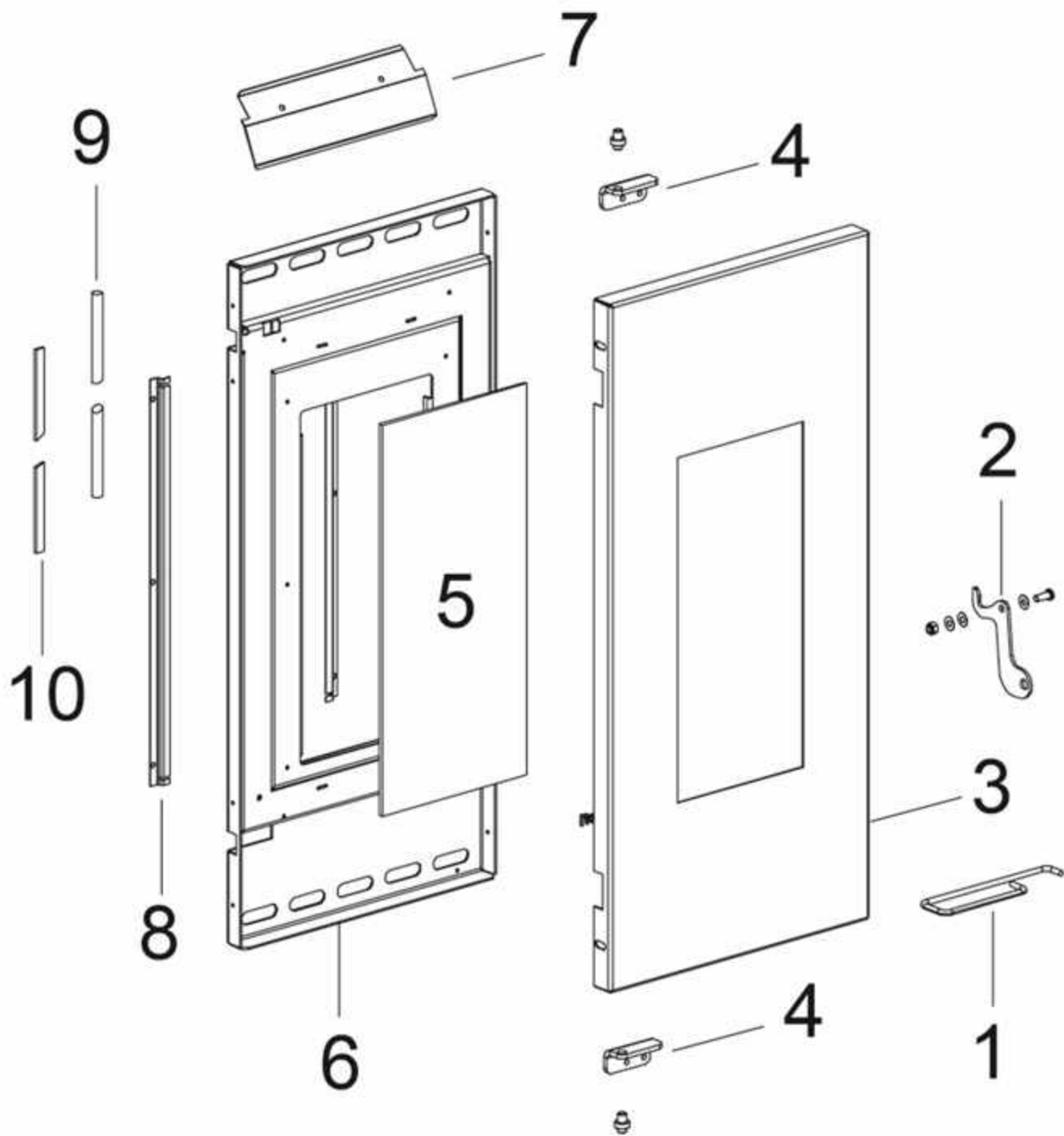

## VENUS3 PLUS

Porta fuoco / Fire door / Feuertür / Porte foyer / Puerta hogar

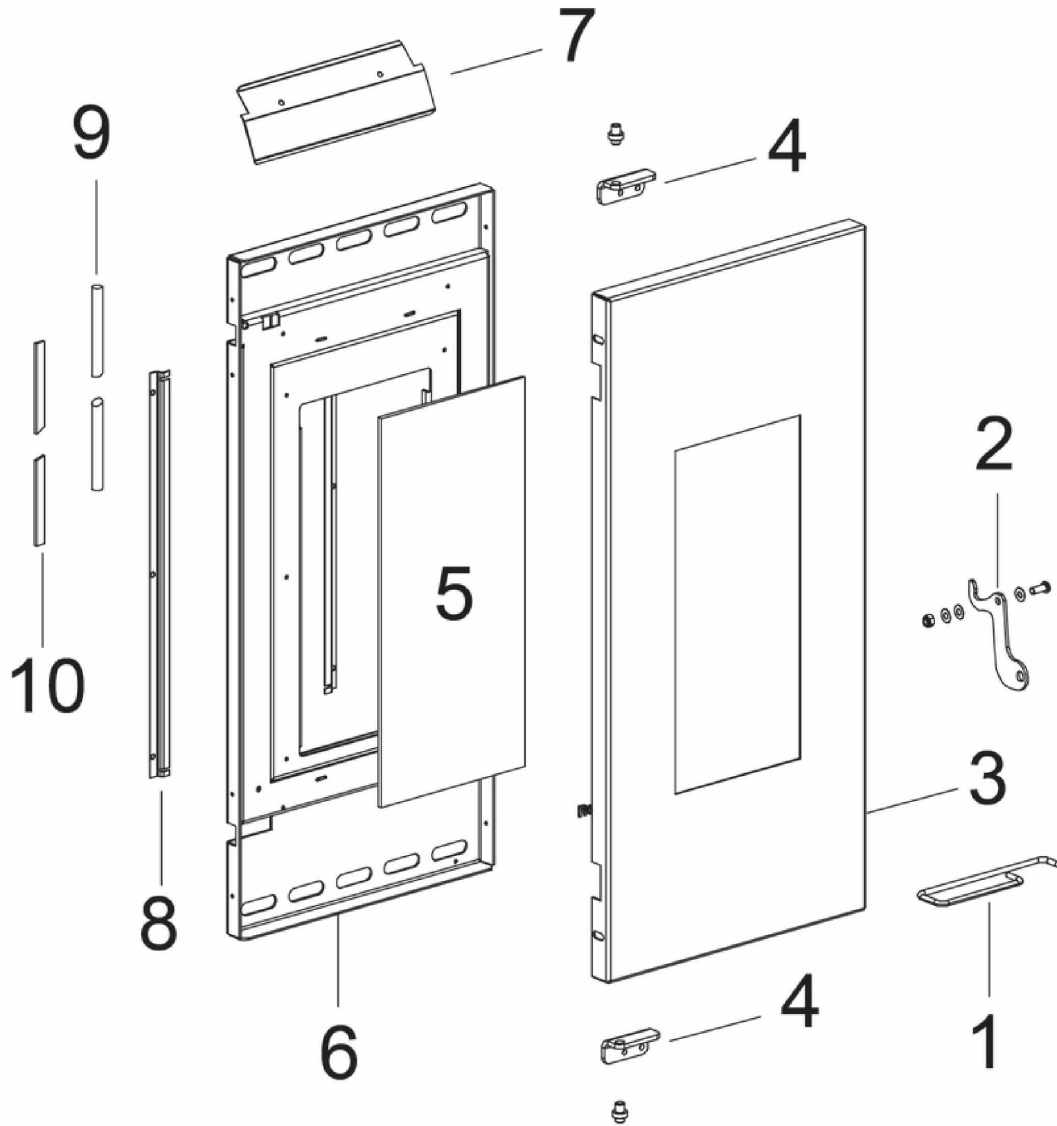

N°	Codice/Code	Descrizioni / Description / Beschreibung / Description / Descripción	Prezzo (€)
1	4D12013060	Gancio "Mano fredda" / Hook "Cold hand" / Haken "Kalte Hand" / Crochet "Main froide" / Gancho "mano fría"	21.00
2	4D24014066161	Maniglia / Handle / Griff / Poignée / Tirador	23.00
2	4D24015841361	Kit decompressione camera di combustione / Pressure relief kit / Bausatz Überdruckablauf Brennkammer / Kit decompression chambre de combustion / Kit decompression cámara de combustión	32.00
3	4D24014048361	Telaio porta esterna / External door frame / Außentürrahmen / Cadre porte extérieure / Armazón puerta exterior	80.00
3	4D13015701061	Telaio porta fuoco in ghisa / Cast iron fire door frame / Feuertürrahment aus Guß / Cadre porte foyer en fonte / Armazón puerta hogar de arrabio	172.00
4	4D2401303720	Supporto porta nero / Black door support / Schwarzes Türhaltebügel / Support porte noir / Soporte puerta negro	21.00
4	4D2401303720	Supporto porta nero / Black door support / Schwarzes Türhaltebügel / Support porte noir / Soporte puerta negro	21.00

5	4D170140010	Vetroceramico 385x175x4 mm / Glass 385x175x4 mm / Glasskeramikscheibe 385x175x4 mm / Vitroc�ramique 385x175x4 mm / Cristal cer�mico 385x175x4 mm	77.00
5	4D170157040	Vetroceramico 379X193X4 / Ceramic glass 379X193X4 / Glaskeramikscheibe 379X193X4 / Vitrec�ramique 379x193x4 mm / Cristal cer�mico 379x193x4 mm	106.00
6	4D24014064461	Telaio porta fuoco / Fire door frame / Feuert�rrahmen / Cadre porte foyer / Armaz�n puerta hogar	122.00
7	4D242140013	Deflettore aria / Air deflector / Luft Leitblech / Deflecteur air / Deflector aire	-
8	4D241140163	Fermavetro / Glass fastening bracket / Halteb�gel f�r Scheibenbefestigung / Etrier de fixation de la vitre / Retendor del cristal	29.00
8	4D2401317703	Fermavetro (pz.2) / Glass fastening brackets (pcs.2) / Halteb�gel f�r Scheibenbefestigung (stk.2) / Etrier de fixation de la vitre (pcs.2) / Retendor del cristal (pz.2)	31.00
9	4D18013021A	Guarnizione treccia nera D.10 - 5 M / Black twist gasket D.10 - 5 M / Dichtung D.10 - 5 M / Joint tresse noire D.10 - 5 M / Junta D.10 - 5 M	33.00
9	4D18013021B	Guarnizione treccia nera D.10 - 50 M / Black twist gasket D.10 - 50 M / Dichtung D.10 - 50 M / Joint tresse noire D.10 - 50 M / Junta D.10 - 50 M	144.00
10	4D18013008A	Guarnizione 10x3 (5m) / Gasket 10x3 (5m) / Dichtung 10x3 (5m) / Joint 10x3 (5m) / Junta 10x3 (5m)	35.00
10	4D18013008C	Guarnizione 10x3 (100m) / Gasket 10x3 (100m) / Dichtung 10x3 (100m) / Joint 10x3 (100m) / Junta 10x3 (100m)	287.00
10	4D18013034A	Guarnizione Tricotex D.6mm (5m) / Gasket Tricotex D.6mm (5m) / Dichtung Tricotex D.6mm (5m) / Joint Tricotex D.6mm (5m) / Junta Tricotex D.6mm (5m)	32.00

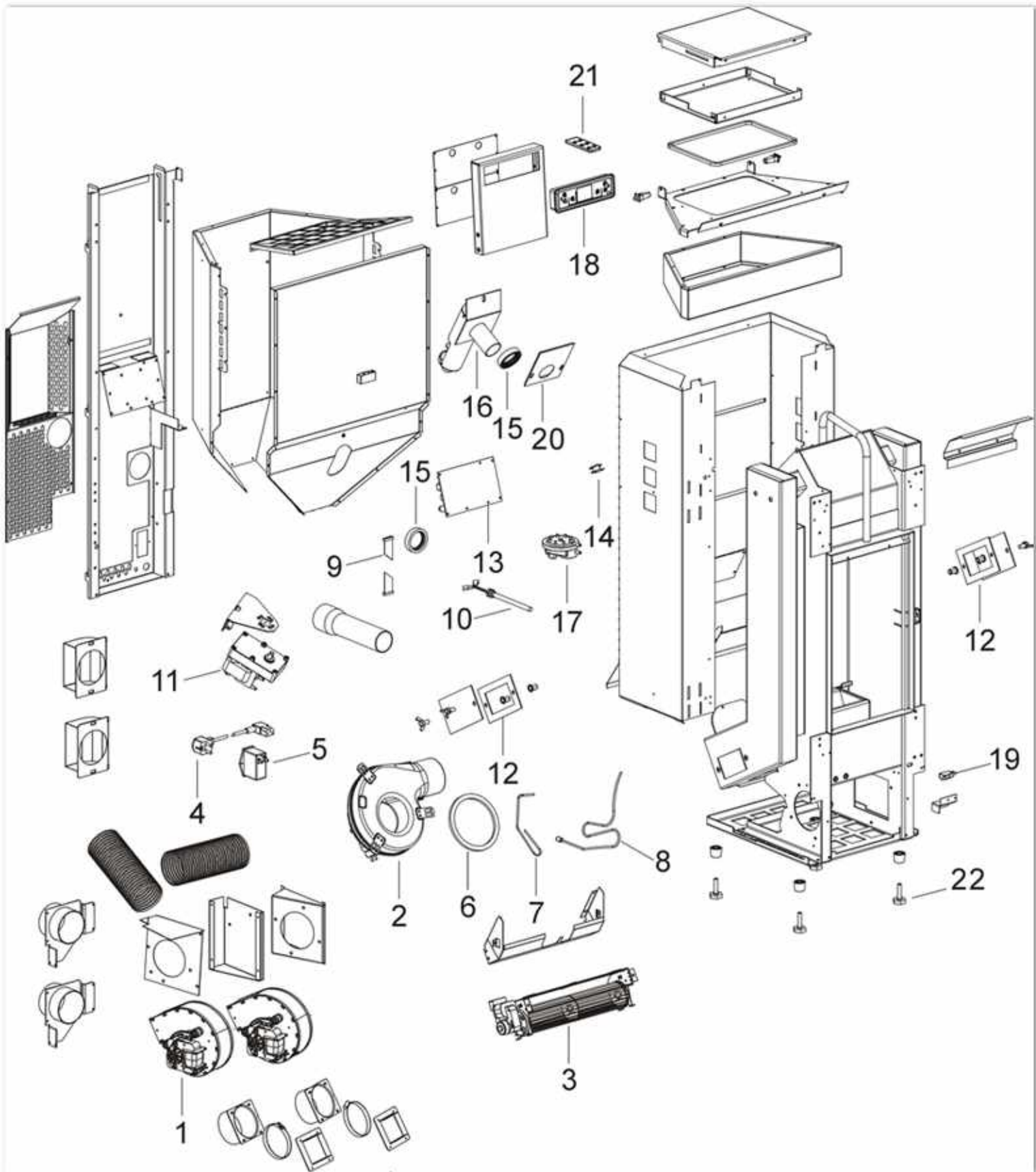

## VENUS3 PLUS

Componenti interni meccanici ed elettronici / Electronic and mechanic internal parts / Interne mechanische und elektronische Bauteile / Composants internes mécaniques et électroniques / Componentes internos electrónicos y mecánicos

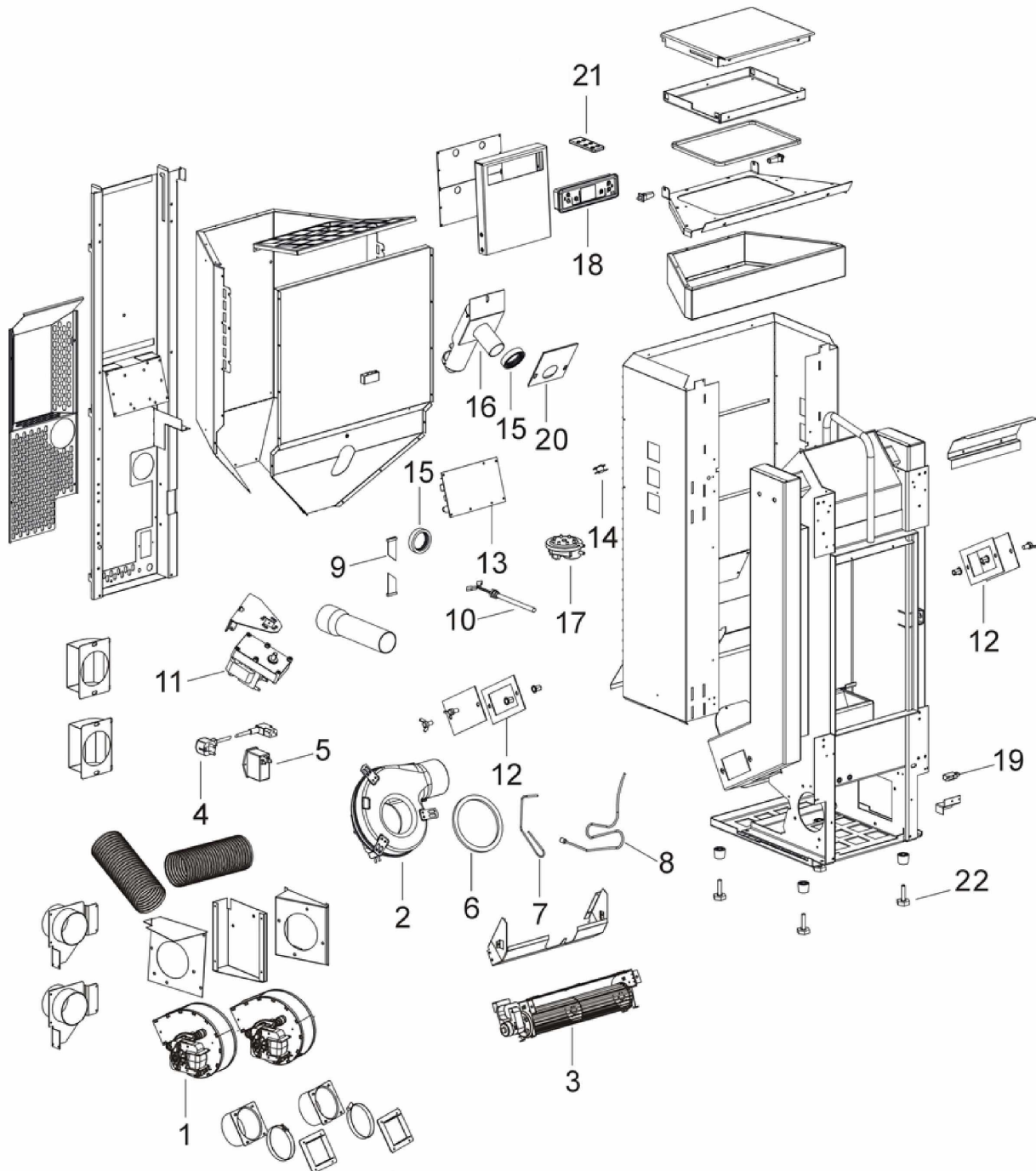

N°	Codice/Code	Descrizioni / Description / Beschreibung / Description / Descripción	Prezzo (€)
1	4D145201070	Ventilatore aria / Air fan / Luftgebläse / Ventilateur air / Ventilador aire	91.00
2	4D145140150	Ventilatore fumi stagno / Air-tight smoke exhausted fan / Luftdichtes Rauchgasgebläse / Ventilateur fumées étanche / Ventilador humos hermético	121.00
2	41801600800	Guarnizione ventilatore fumi / Smoke exhaust fan gasket / Dichtung Rauchabsauggebläse / Joint Ventilateur aspiration fumées / Junta ventilador aspiración humos	22.00
2	41451209300	Encoder per ventilatore fumi marchi LN2/SIT / Encoder for LN2/SIT smoke fan / Encoder für LN2/SIT Rauchgasgebläse / Encoder pour ventilateur des fumées marques LN2/SIT / Encoder para ventilador humos marcas LN2/SIT	21.00

3	4D14513004	Ventilatore aria / Air fan / Luftgebläse / Ventilateur air / Ventilador aire	69.00
4	4D14513041	Cavo alimentazione / Power source cable / Zündungskabel / Câble alimentation / Cable alimentación	25.00
5	4D14513090	Pulsante accensione / On/Off button / Zündungstaste / Touche d'allumage / Botón encendido	36.00
6	4D18013024	Guarnizione / Gasket / Dichtung / Joint / Junta	26.00
7	4D145150090	Sonda fumi / Smoke sensor / Rauchsonde / Sonde fumées / Sonda humos	28.00
8	4D145150110	Sonda ambiente / Room temperature sensor / Raumtemperaturfühler / Sonde température ambiance / Sonda ambiente	23.00
9	4D14513007	Cavo flat scheda-pannello / Flat cable motherboard-control panel / Flat Kabel Hauptplatine-Bedienblende / Câble flat carte mère-panneau commande / Cable flat tarjeta madre-panel de mandos	31.00
10	4D14513002	Candeletta / Sparkplug / Zündkerze Pelletzündung / Bougie / Bujía encendido pellet	50.00
10	4D145181040	Candeletta / Sparkplug / Zündkerze / Bougie / Bujía	51.00
11	4D145159010	Motoriduttore 3,3 rpm / Reduction motor 3,3 rpm / Getriebemotor 3,3 rpm / Motorréducteur 3,3 rpm / Motorreductor 3,3 rpm	120.00
11	4D145181020	Motoriduttore 2 rpm / Reduction motor 2 rpm / Getriebemotor 2 rpm / Motorréducteur 2 rpm / Motorreductor 2 rpm	107.00
12	4D18013001	Guarnizione 130x80 mm / Gasket 130x80 mm / Dichtung 130x80 mm / Joint 130x80 mm / Junta 130x80 mm	26.00
12	4D18013001	Guarnizione 130x80 mm / Gasket 130x80 mm / Dichtung 130x80 mm / Joint 130x80 mm / Junta 130x80 mm	26.00
13	4D14513064B	Scheda madre / Motherboard / Hauptplatine / Carte mère / Tarjeta madre	233.00
13	4D145181060	Scheda madre L023-V5-64K / Motherboard L023-V5-64K / Hauptplatine L023-V5-64K / Carte mère L023-V5-64K / Tarjeta madre L023-V5-64K	183.00
14	4D14513006	Termostato 60°C / Thermostat 60°C / Thermostat 60°C / Thermostat 60°C / Termostato 60°C	48.00
15	4D18013003	Guarnizione D.50 mm / Gasket D.50 mm / Dichtung D.50 mm / Joint D.50 mm / Junta D.50 mm	26.00
15	4D18013003	Guarnizione D.50 mm / Gasket D.50 mm / Dichtung D.50 mm / Joint D.50 mm / Junta D.50 mm	26.00
16	4D140160030	Coclea di caricamento pellet / Pellet feed screw / Pelletsförderschnecke / Vis sans fin pour chargement du pellet / Cóclea de carga pellet	163.00
16	4D180177070	Coclea di caricamento pellet / Pellet feed screw / Pelletsförderschnecke / Vis sans fin pour chargement du pellet / Cóclea de carga pellet	141.00
16	4D180177010	Boccola / Bushing / Buchse / Douille / Abrazadera	23.00
17	4120631A	Tubicino siliconico - 5m / Silicon tube - 5m / Silikonrohr - 5m / Petit tuyau en silicone - 5m / Tubo silicónico - 5m	22.00
17	4160482	Pressostato 0,4 mbar / Pressure gauge 0,4 mbar / Druckwächter 0,4 mbar / Pressostat 0,4 mbar / Presostato 0,4 mbar	38.00
18	4D14513032	Pannello comandi / Control panel / Bedienblende / Tableau de commande / Panel de mandos	114.00
18	4D1451303300	Pannello comandi grafico / Graphic control panel / Graphische Bedienblende / Tableau de commande / Panel de mandos gráfico	138.00
19	4D14513030	Interruttore di sicurezza della porta fuoco / Fire door safety switch / Microswitch / Interrupteur de sécurité porte foyer / Microswitch	18.00
20	4D18013004	Guarnizione 100X108 mm / Gasket 100X108 mm / Dichtung 100x108 mm / Joint 100X108 mm / Junta 100X108 mm	28.00
21	5019012	Telecomando / Remote control / Fernbedienung / Télécommande / Mando a distancia	55.00
22	4D12013006	Piedini di appoggio (4 pz.) / Support feet (4 pcs.) / Einstellfüße (4 Stck.) / Vérins (4 pcs) / Pies de apoyo (4 pzs)	25.00
23	4D241140013	Carter posteriore / Back carter / Hinteres Blech / Protection arrière / Carter trasero	71.00