

AQUOS 24 H2O

Componenti Struttura Esterna / External structure components / Bauteile Aussenkorpus / Composants structure externe / Componentes estructura externa

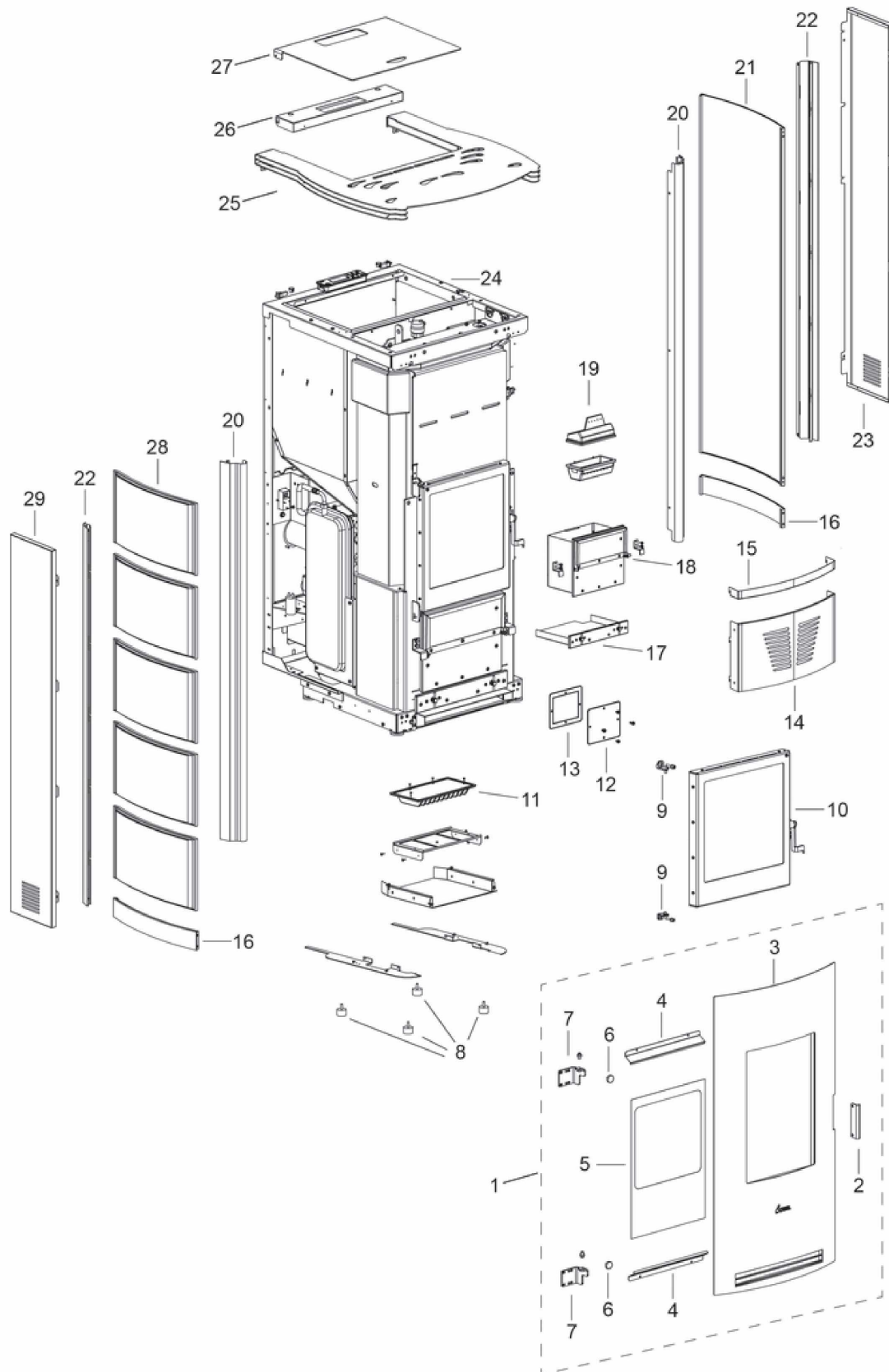

N°	Codice/Code	Descrizioni / Description / Beschreibung / Description / Descripcion	Prezzo (€)
1	4D245GP15007	Porta esterna completa / Complete external door / Komplette externe Tür / Porte extérieur complete / Puerta exterior completa	352.00
2	4D242156013	Maniglia porta esterna / External door handle / Griff externer Tür / Poignée porte extérieur / Tirador puerta externa	25.00
3	4D24015634463	Telaio porta esterna / External door frame / Rahmen externer Tür / Cadre porte extérieur / Armazón externo puerta	231.00
4	4D24015615363	Fermavetro / Guard glas / Haltebügel für Scheibenbefestigung / Etrier de fixation de la vitre / Fermacrystal	33.00
4	4D24015615363	Fermavetro / Guard glas / Haltebügel für Scheibenbefestigung / Etrier de fixation de la vitre / Fermacrystal	33.00
5	4D17013022	Vetroceramico 442,5X288X4 mm / Ceramic glass 442,5X288X4 mm / Glaskeramikscheibe 442,5X288X4 mm / Vitreoceramique 442,5X288X4 mm / Cristal cerámico 442,5X288X4 mm	114.00
6	4D14013104	Perno porta (2pz) / Door pivot (2pcs) / Türscharnierstift (2stck) / Pivot porte (2pcs) / Peral puerta (2pz)	24.00
6	4D14013104	Perno porta (2pz) / Door pivot (2pcs) / Türscharnierstift (2stck) / Pivot porte (2pcs) / Peral puerta (2pz)	24.00
7	4D24015605363	Cerniera / Hinge / Scharnier / Charnière / Bisagra	30.00
7	4D24015605363	Cerniera / Hinge / Scharnier / Charnière / Bisagra	30.00
8	41201104200	Piedini di appoggio (4 pz) / Support feet (4 pcs) / Einstellfüße (4 Stck) / Vérins d'appui (4 pcs) / Pies de apoyo (4 pz)	35.00
9	412008063	Cerniere porta fuoco (2 pz) / Fire door hinge (2pcs) / Scharnier Feuertür (2 Stck) / Charnière porte foyer (2 pcs) / Bisagra puerta del hogar (2 pz)	27.00
9	412008063	Cerniere porta fuoco (2 pz) / Fire door hinge (2pcs) / Scharnier Feuertür (2 Stck) / Charnière porte foyer (2 pcs) / Bisagra puerta del hogar (2 pz)	27.00
10	437012055	Porta fuoco completa / Complete finished door / Komplette Tür / Porte finie complète / Puerta completa	237.00
11	41300901100	Scambiatore in ghisa / Cast iron exchanger / Gusseiserne Wärmetauscher / Echangeur en fonte / Intercambiador en arrabio	86.00
12	43641024A1	Tappo ispezione vano fumi / Smoke compartment inspection plug / Inspektionskappe Rauchabzug / Clapet inspection compartiment fumées / Tapón inspección compartimento humos	20.00
13	41801209600	Guarnizione / Gasket / Dichtung / Joint / Junta	20.00
14	4D24015628463	Pannello frontale superiore nero 80° / Frontal upper panel black 80° / Oberes Frontpaneel schwarz 80° / Panneau supérieur frontal noir / Panel superior frontal negro	78.00
15	4D242156023	Profilo frontale superiore inox / Upper front profile inox / oberes Frontprofil Inox / Profil frontal supérieur Inox / Perfil frontal superior inox	35.00
16	4D24015627463	Chiusura fianco laterale nero 80° / Side closing black 80° / Untere Paneel Seitenteil schwarz 80° / Fermeture côté lateral noir 80° / Cierre lateral negro 80°	55.00
16	4D24015627463	Chiusura fianco laterale nero 80° / Side closing black 80° / Untere Paneel Seitenteil schwarz 80° / Fermeture côté lateral noir 80° / Cierre lateral negro 80°	55.00
17	41401129530	Cassetto cenere inferiore / Lower ash drawer / Unteres Aschenkasten / Tiroir à cendres inférieur / Cajón ceniza inferior	103.00
18	41401129630V	Cassetto cenere superiore / Upper ash drawer / Oberer Aschenkasten / Tiroir à cendres supérieur / Cajón ceniza superior	123.00
19	4130120050100	Braciere in ghisa / Cast iron combustion pot / Brennerpotf aus Gusseisen / Brasero en fonte / Brasero de arrabio	114.00
20	4D24015618363	Binario Maioliche anteriore nero 80° / Front rod for ceramics black 80° / Vordere Montageleiste Schwarz 80° / Voie ceramiques antérieur noir 80° / Montante anterior cerámica negro 80°	58.00
20	4D24015618363	Binario Maioliche anteriore nero 80° / Front rod for ceramics black 80° / Vordere Montageleiste Schwarz 80° / Voie ceramiques antérieur noir 80° / Montante anterior cerámica negro 80°	58.00
21	6915021	Rivestimento completo metallo Avorio / Complete Ivory metal cladding / Komplette Verkleidung Metall Elfenbein / Habillage complète métal Ivoire / Revestimiento completo metal Marfil	109.00
21	6915022	Rivestimento completo metallo Rosso / Complete Red metal cladding / Komplette Verkleidung Metall Rot / Habillage complète métal Rouge / Revestimiento completo metal Rojo	109.00
22	4D24015619363	Binario maioliche posteriore nero 80° / Rear rod for ceramics black 80° / Hintere Montageleiste Schwarz 80° / Voie ceramiques posterieur noir 80° / Montante posterior cerámica negro 80°	59.00
22	4D24015619363	Binario maioliche posteriore nero 80° / Rear rod for ceramics black 80° / Hintere Montageleiste Schwarz 80° / Voie ceramiques posterieur noir 80° / Montante posterior cerámica negro 80°	59.00
23	4D24015631363	Carter posteriore DX nero 80° / R. Rear guard black 80° / Hintere Kurbelgehäuse RE schwarz 80° / Dosseret posterieur droite noir 80° / Carter posterior DCHO negro 80°	66.00
24	41401245730V	Top in acciaio inferiore / Lower steel top / Untere Stahlabdeckplatte / Dessus en acier inférieur / Top en acero inferior	81.00
25	4D24015629463	Top nero 80° / Black top / Schwarzes Topplatte 80° / Dessus noir 80° / Top negro 80°	185.00
26	4D24015609363	Porta display nero 80° / Display stand black 80° / Displayträger schwarz 80° / Support tableau de commande noir 80° / Soporte panel de mandos negro 80°	84.00
27	4D24015625363	Coperchio serbatoio pellet nero 80° / Pellet hopper cover 80° (black) / Deckel Pelletbehälter schwarz 80° / Couvercle reservoir pellet noir 80° / Tapadera depósito pellet	63.00
28	4D12512032	Ceramica laterale avorio / Ivory side ceramic / Seitliche Keramik Elfenbein / Céramique latérale ivoire / Cerámica lateral marfil	-

28	4D12512031	Ceramica laterale rosso / Red side ceramic / Seitliche Keramik Rot / Céramique latérale rouge / Cerámica lateral rojo	-
28	4D12512033	Ceramica laterale nero brillante / Sparkling black side ceramic / Seitliche Keramik glänzend Schwarz / Céramique latérale noire brillante / Cerámica lateral negro brillante	-
29	4D24015630363	Carter posteriore SX nero 80° / L. Rear guard black 80° / Hintere Kurbelgehäuse LI schwarz 80° / Dosseret posterieur gauche noir 80° / Cárter posterior IZDA negro 80°	67.00

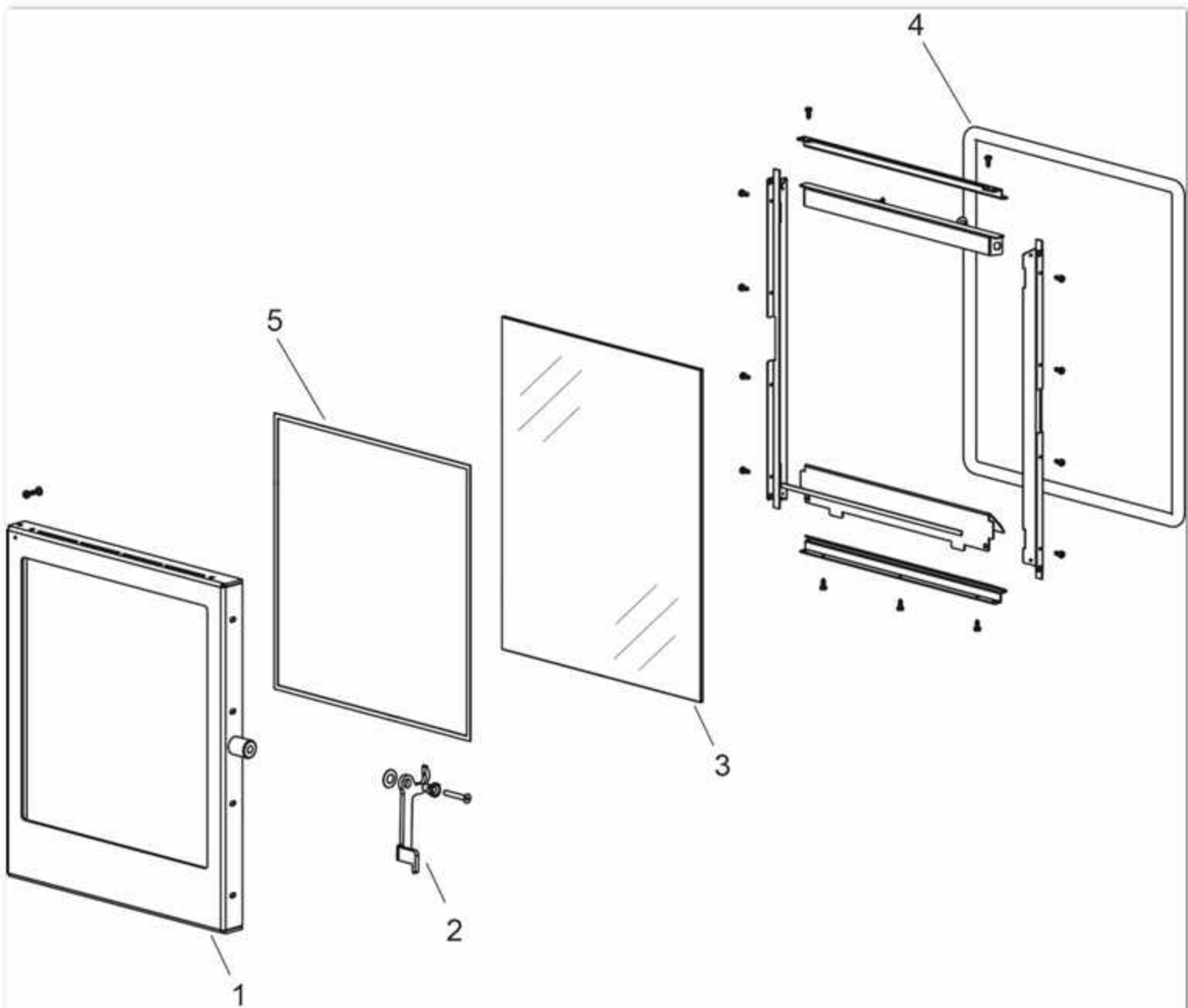

AQUOS 24 H2O

Porta fuoco / Fire door / Feuertür / Porte foyer / Puerta hogar

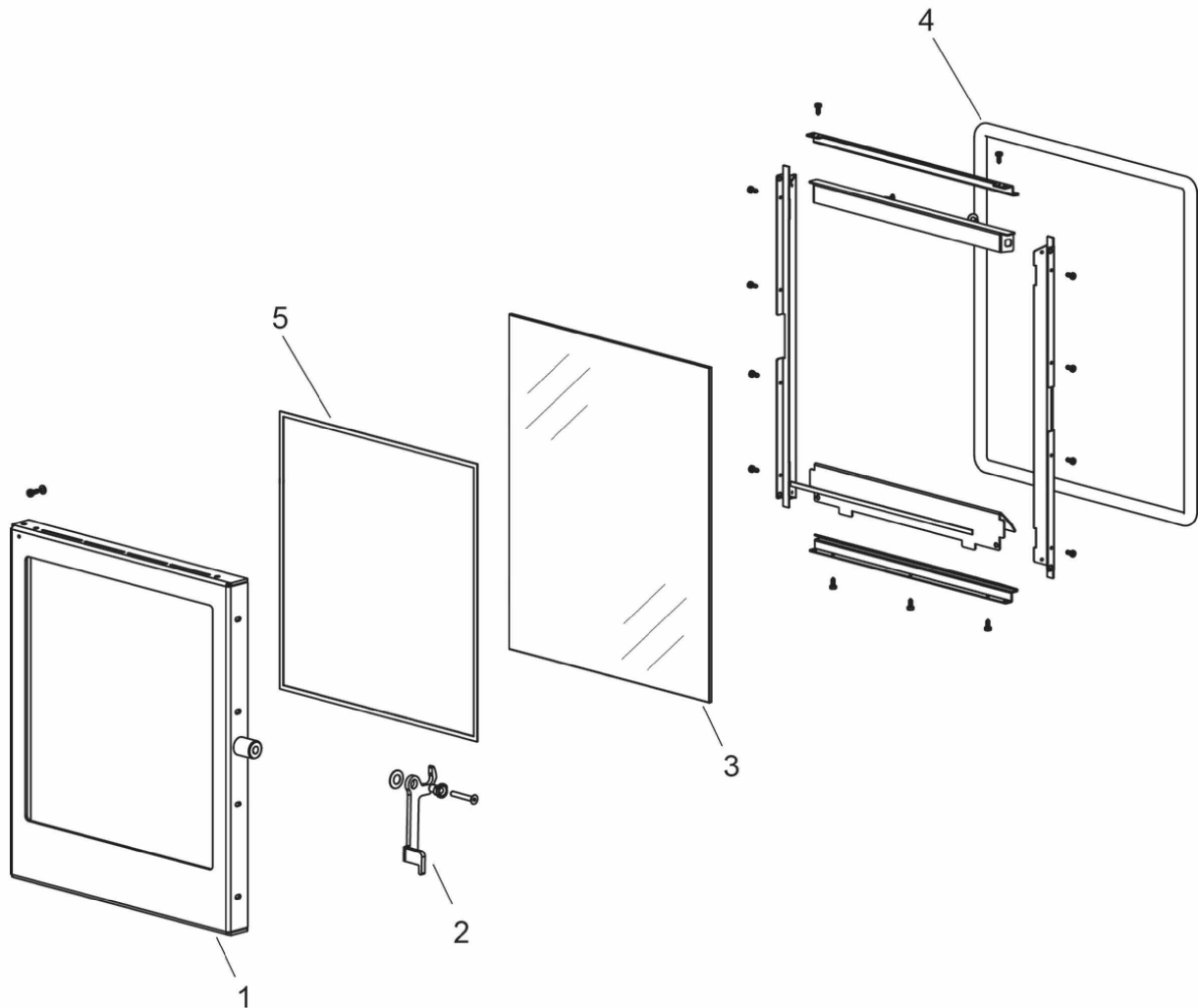

N°	Codice/Code	Descrizioni / Description / Beschreibung / Description / Descripción	Prezzo (€)
1	41401246541V	Telaio porta fuoco / Fire door frame / Feuertürrahmen / Cadre porte foyer / Armazón puerta de arrabio	67.00
2	41401247130V	Maniglia / Handle / Griff / Poignée / Tirador	21.00
3	41701200100	Vetroceramico / Glass / Glaskeramikscheibe / Vitrocéramique / Cristal cerámico	205.00
4	41201203700A	Guarnizione con anima in metallo Ø 15 (5 M) / Gasket with metallic core Ø 15 (5 M) / Dichtung mit Metalseele Ø 15 (5 M) / Joint avec nuyau métallique Ø 15 (5 M) / Junta con alma metálica Ø 15 (5 M)	69.00
4	41201203700B	Guarnizione con anima in metallo Ø 15 (50 M) / Gasket with metallic core Ø 15 (50 M) / Dichtung mit Metalseele Ø 15 (50 M) / Joint avec nuyau métallique Ø 15 (50 M) / Junta con alma metálica Ø 15 (50 M)	559.00
5	4120572A	Guarnizione a nastro 6 mm (5 mt.) per porta / Door strip gasket 6 mm (5 m) / Türbanddichtung 6 mm (5 m) / Joint ruban 6 mm (5 m) pour porte / Guarnición de cinta para puerta 6 mm (5 m)	33.00
5	4120572B	Guarnizione a nastro 6 mm (50 mt.) per porta / Door strip gasket 6 mm (50 m) / Türbanddichtung 6 mm (50 m) / Joint ruban 6 mm (50 m) pour porte / Guarnición de cinta para puerta 6 mm (50 m)	210.00

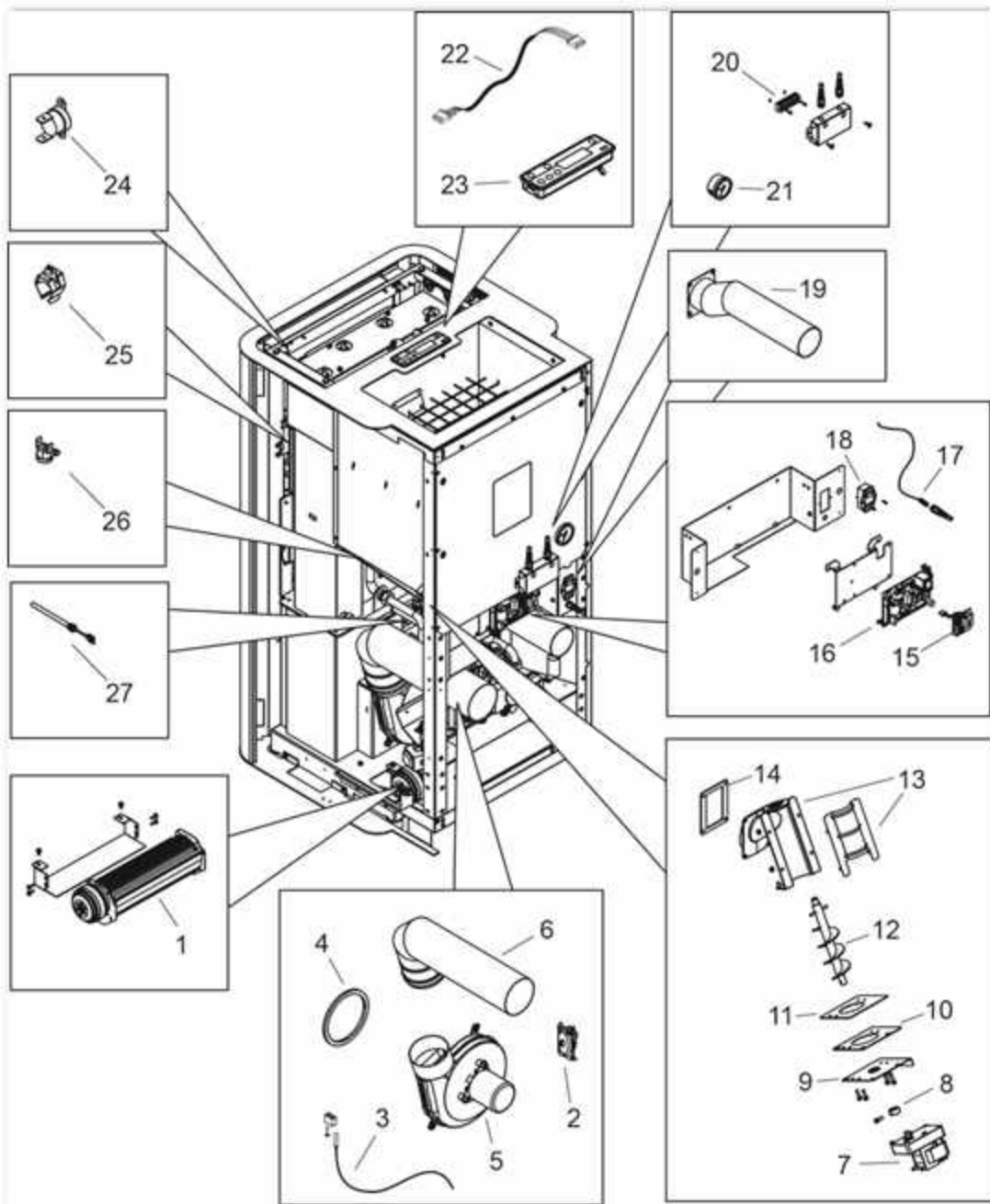

AQUOS 24 H2O

Componenti interni elettronici e meccanici / Electronic and mechanical internal components / Interne elektronische und mechanische Bauteile / Composants électroniques et mécaniques internes / Componentes internos electrónicos y mecánicos

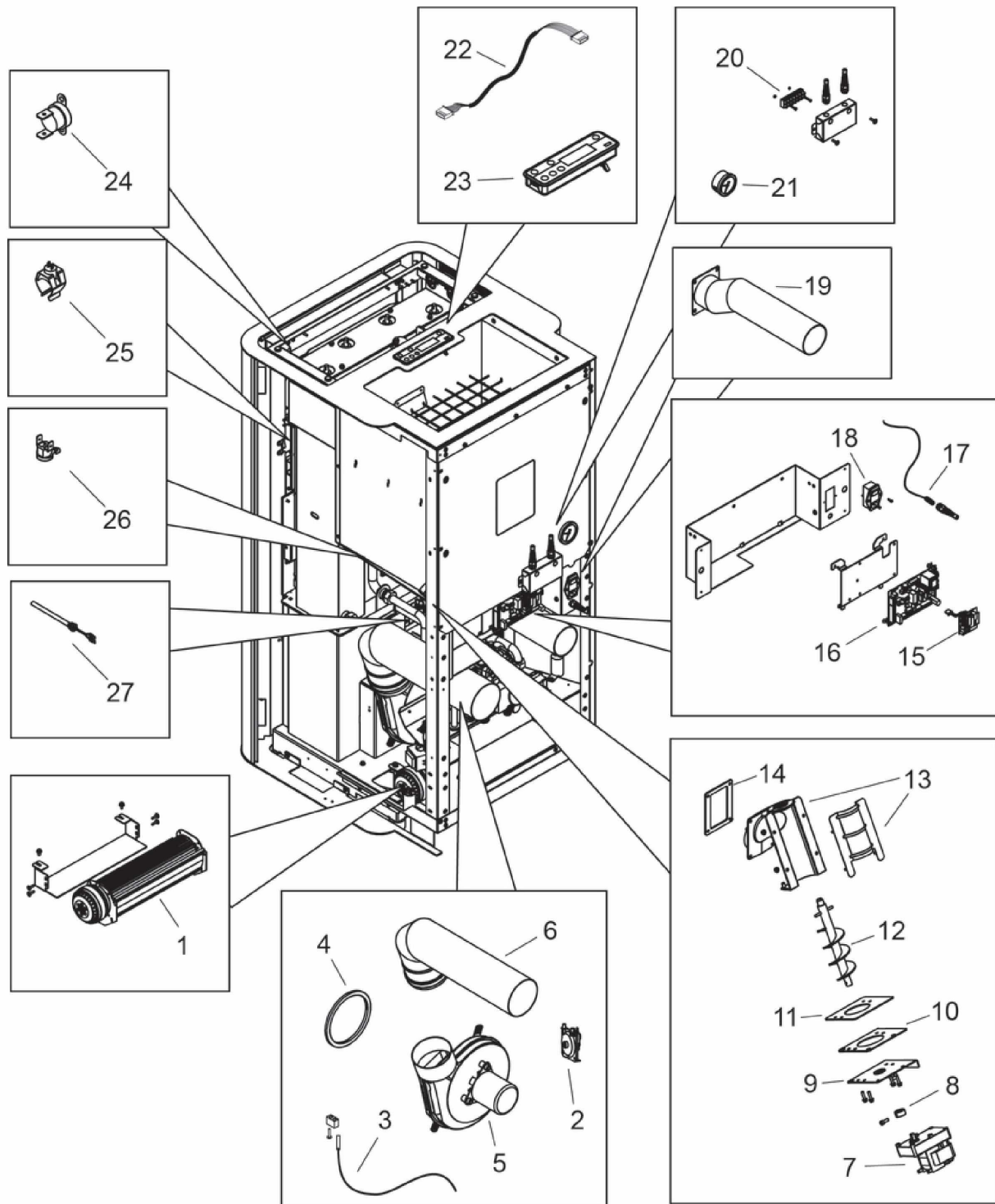

N°	Codice/Code	Descrizioni / Description / Beschreibung / Description / Descripción	Prezzo (€)
1	41451001701	Ventilatore aria calda / Warm air fan / Warmluftgebläse / Ventilateur air chaud / Ventilador aire caliente	176.00
2	4160482	Pressostato 0,4 mbar / Pressure gauge 0,4 mbar / Druckschalter 0,4 mbar / Pressostat 0,4 mbar / Presostato 0,4 mbar	38.00
3	41451002300	Sonda fumi / Smoke sensore / Rauchgassonde / Sonde fumées / Sonda humos	31.00

4	41801100100	Guarnizione adesiva voluta fumi / Adhesive gasket smoke volute / Haftenddichtung Rauchvolute / Joint adhesive volute fumées / Junta adhesiva voluta humos	21.00
5	41451100300	Ventilatore aspirazione fumi con encoder / Smoke exhausted fan WITH encoder / Rauchabsauggebläse MIT Encoder / Ventilateur aspiration fumées AVEC encoder / Ventilador aspiración humos con codificador	220.00
5	41801803900	Guarnizione ø212 / Gasket ø212 / Dichtung ø212 / Joint ø212 / Junta ø212	20.00
6	41601103960	Tubo uscita fumi / Smoke outlet pipe / Rohr Rauchabzug / Tuyau sortie fumées / Tubo salida humos	66.00
7	41450901600	Motoriduttore 3,3 rpm Merkle Korff / Reduction motor 3,3 rpm Merkle Korff / Getriebemotor 3,3 RPM MERKLE KORFF / Motoréducteur 3,3 RPM MERKLE KORFF / Motorreductor 3,3 rpm Merkle Korff	114.00
8	4120398	Connettore motoriduttore-coclea / Reduction motor-feed screw connector / Verbindung Getriebemotor-Schnecke / Connecteur motoréducteur-vis sans fin / Conector motorreductor-cóclea	22.00
9	41400944351	Base della coclea / Feed screw base / Untergestell der Förderschnecke / Base de la vis sans fin / Base de la cóclea	25.00
10	41400903310	Flangia condotto coclea / Base of feed screw conduit / Untergestell Rohrleitung der Förderschnecke / Base du conduit de la vis sans fin / Base de conducto de la cóclea	20.00
11	4120615	Guarnizione base della coclea / Feed screw base gasket / Dichtung Untergestell der Förderschnecke / Joint pour la base de la vis sans fin / Junta base de la cóclea	19.00
12	41200901040	Coclea di caricamento pellet / Pellet feed screw / Pelletsförderschnecke / Vis sans fin pour chargement du pellet / Cóclea de carga pellet	46.00
13	41401077540V	Condotto della coclea / Conduit of feed screw / Rohrleitung der Förderschnecke / Conduit de la vis sans fin / Conducto de la cóclea	81.00
14	418008029	Guarnizione / Gasket / Dichtung / Joint / Junta	21.00
15	41451104900	Scheda aggiuntiva hydro / Supplementary mother board Hydro / Zusätzliche Platine Hydro / Carte mère additionnelle Hydro / Tarjeta adicional Hydro	53.00
16	41451200500	Scheda madre completa MICRONOVA / Complete mother board MICRONOVA / Komplette Hauptplatine MICRONOVA / Carte mère complete MICRONOVA / Tarjeta madre completa MICRONOVA	239.00
17	4160386	Sonda temperatura ambiente/acqua / Room/Water temperature sensor / Raum- Wassertemperaturfühler / Sonde température ambiance/eau / Sonda temperatura ambiente/agua	21.00
18	41451107400	Pulsante accensione / On/Off button / Zündungstaste / Touche d'allumage / Botón encendido	45.00
19	41601201960	Tubo aspirazione aria comburente / Combustion air aspiration tube / Verbrennungsluft Förderrohr / Tuyau aspiration air comburant / Tubo aspiración aire de combustión	43.00
20	41451202000	Morsettiera / Terminal board / Klemmenbret / Serre-câble / Borne	25.00
21	41501100901	Manometro / Manometer / Manometer / Manomètre / Manómetro	42.00
22	41451201900	Cavo Flat L 1,4 M / Flat cable L 1,4 M / Flat Kable L 1,4 M / Câble Flat L 1,4 M / Cable Flat L 1,4 M	21.00
23	4D1451303300	Pannello comandi grafico / Graphic control panel / Graphische Bedienblende / Tableau de commande / Panel de mandos gráfico	138.00
24	41450901100	Clickson 95°C / Clickson 95°C / Clickson 95°C / Clickson 95°C / Clickson 95°C	20.00
25	41450901200	Sonda temperatura acqua / Water temperature sensor / Wassertemperaturfühler / Sonde température eau / Sonda temperatura agua	26.00
26	412007004	Clickson 110°C / Clickson 110°C / Clickson 110°C / Clickson 110°C / Clickson 110°C	20.00
27	41451209600	Candeletta accensione pellet 350 W / Pellet ignition sparkplug 350 W / Zündkerze Pelletzündung 350 W / Bougie d'allumage pellet 350 W / Bujía encendido pellet 350 W	45.00

AQUOS 24 H2O

Gruppo scambiatore / Exchanger group / Austausch Baugruppe / Groupe échangeur / Grupo intercambiador

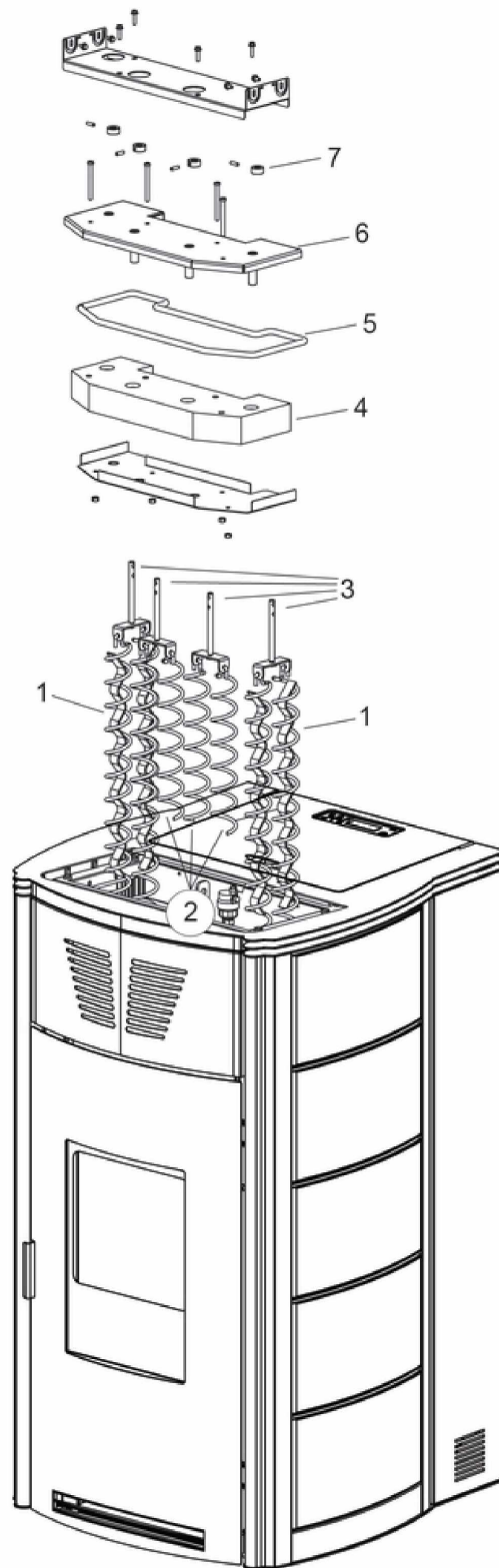

N°	Codice/Code	Descrizioni / Description / Beschreibung / Description / Descripción	Prezzo (€)
1	41201302500	Eliche raschiatore Inox (1 pz.) / Inox Turbulator props (1 pc.) / Propeller des Schabers Inox (1 Teil) / Hélices turbulateur Inox (1 pz.) / Hélice rascador Inox (1 pz.)	47.00
1	41201302500	Eliche raschiatore Inox (1 pz.) / Inox Turbulator props (1 pc.) / Propeller des Schabers Inox (1 Teil) / Hélices turbulateur Inox (1 pz.) / Hélice rascador Inox (1 pz.)	47.00
2	41201302400	Eliche raschiatore Inox (1 pz.) / Inox Turbulator props (1 pc.) / Propeller des Schabers Inox (1 Teil) / Hélices turbulateur Inox (1 pz.) / Hélice rascador Inox (1 pz.)	33.00
3	41401129341	Staffa sostegno raschiatore Inox / Inox turbulator support bar / Haltebügel des Schabers aus Inox / Etrier support turbulateur en Inox / Zuncho apoyo rascador de Inox	28.00
4	41151101100	Pannello Calorite coperchio caldaia / Boiler cover Calorite panel / Kesseldeckepaneel aus Calorite / Panneau en calorite couvercle chaudière / Panel en Calorite tapa caldera	44.00
5	4120103A	Cordino fibroceramico Ø 10 mm (5 mt.) / Ceramic fibre cord Ø 10 mm (5 m) / Keramikfaserschnur Ø 10 mm (5 m) / Cordon en fibre céramique Ø 10 mm (5 m) / Junta a cuerda de fibra cerámica Ø 10 mm (5 m)	29.00
6	41401129140V	Coperchio scambiatore / Exchanger cover / Deckel des Austauschers / Couvercle Echangeur / Tapa intercambiador	70.00
7	41200903300	Trascinatore turbolatori (2 pz.) / Turbolator props puller (2 PC.) / Reinigungsspiralenmitnehmer (2 STCK). / Meneur de turbolateur (2 Pc.) / Arrebatador hélice rascador (2 pz.)	25.00

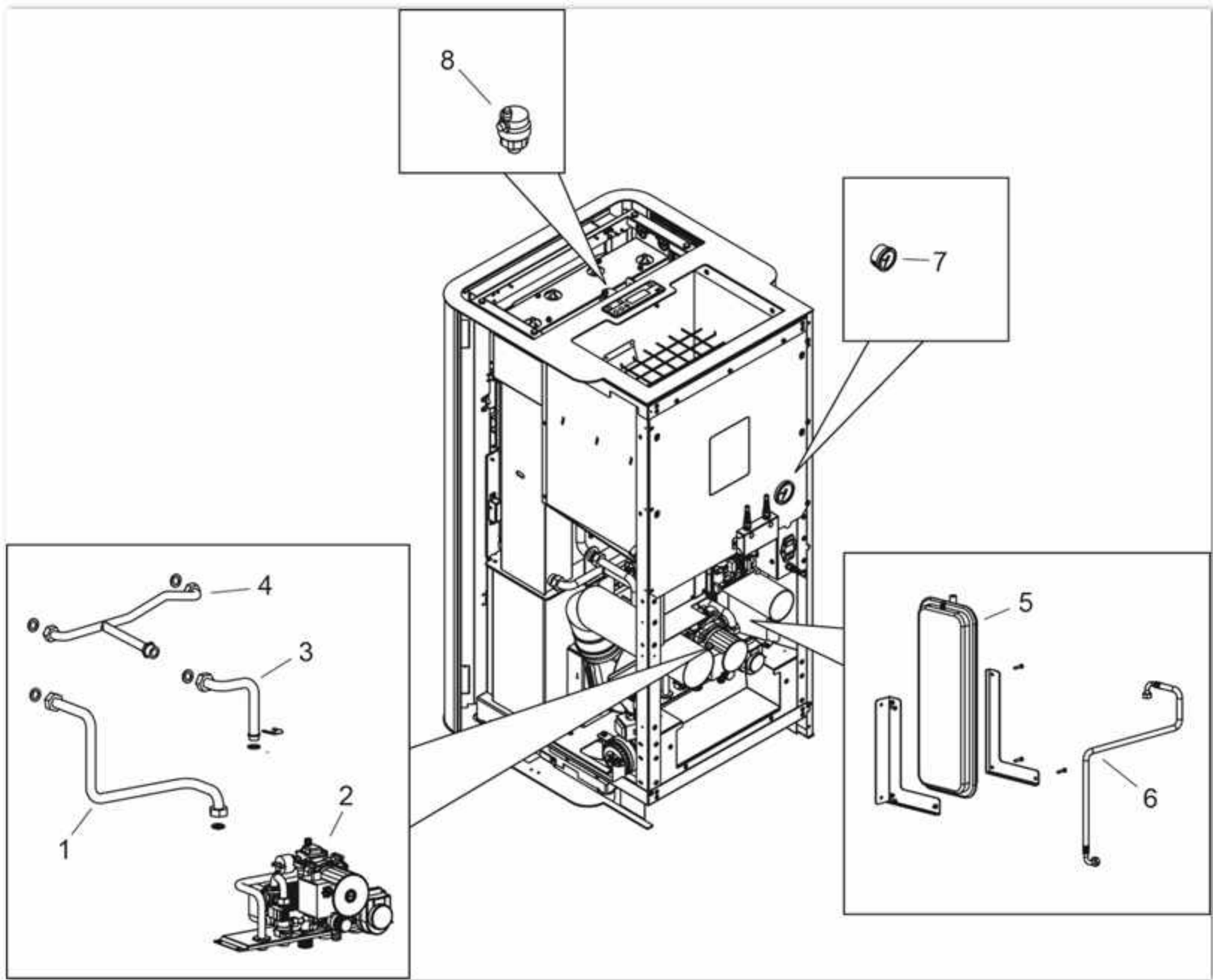

AQUOS 24 H2O

Componenti interni idraulici CON kit acqua sanitaria / Internal plumbing components WITH domestic water kit / Interne hydraulische Bauteile MIT Brauchwassersatz / Composants hydrauliques internes AVEC kit eau sanitaire / Componentes internos hidráulicos CON kit de agua sanitaria

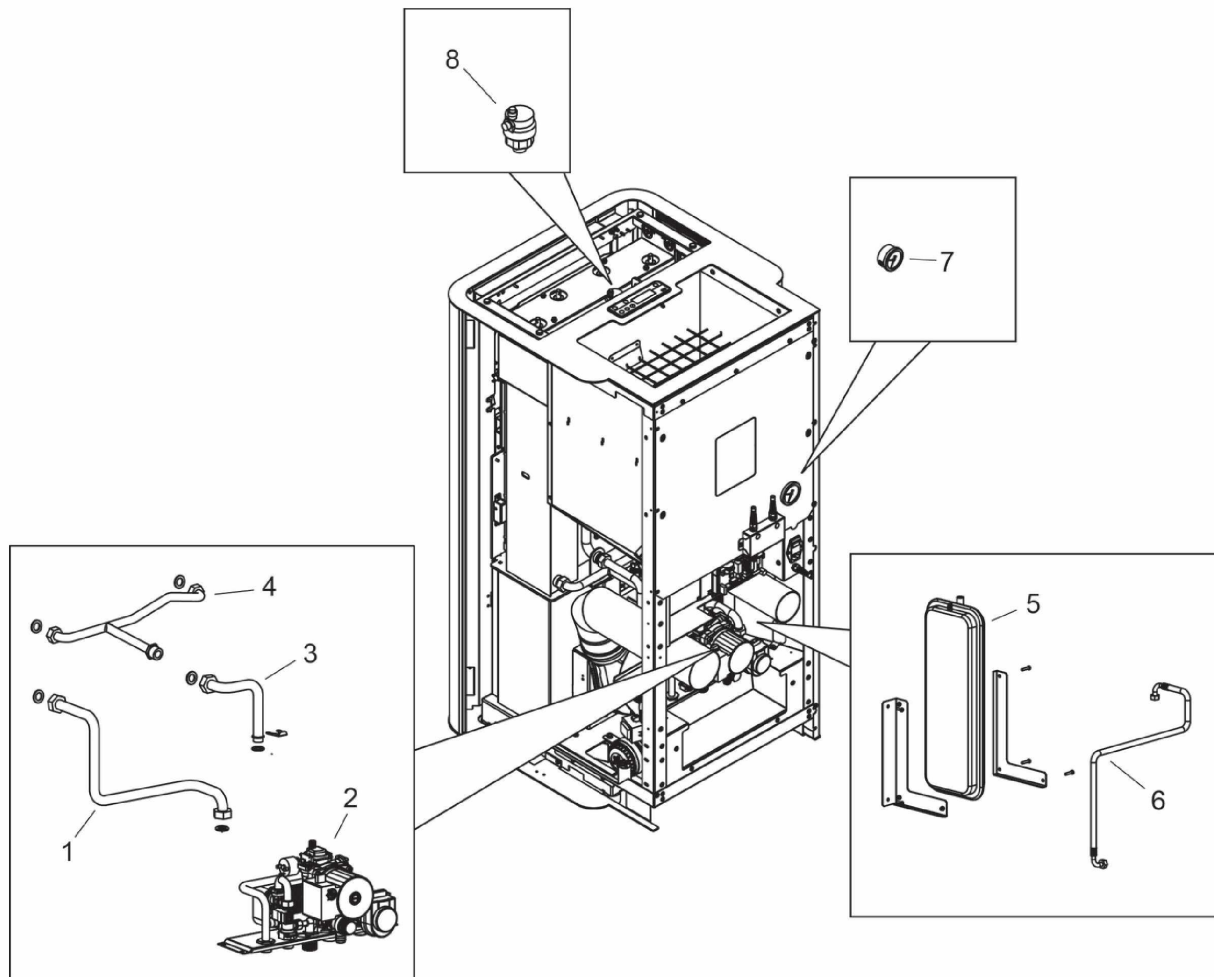

N°	Codice/Code	Descrizioni / Description / Beschreibung / Description / Descripción	Prezzo (€)
1	41501203400	Tubo di mandata riscaldamento - con circolatore alta efficienza / Heating water delivery tube - with high efficiency circulation pump / Heizungsvorlaufrohr - mit Hochleistungs-Zirkulator / Tuyau de refoulement eau chauffage - avec circulateur à haut rendement / Tubo de envío de agua calentamiento - con bomba alto rendimiento	40.00
2	41501203301	Gruppo idraulico - con produzione acqua sanitaria - con circolatore alta efficienza / Hydraulic unit - with domestic hot water production - with high efficiency circulation pump / Hydraulikeinheit - mit Brauchwarmwasser Herstellung - mit Hochleistungs-Zirkulator / Unité hydraulique - avec production eau chaude sanitaire - avec circulateur à haut rendement / Unidad hidráulica - con producción agua caliente sanitaria - con bomba alto rendimiento	0.00
2	41501103300	Valvola di sicurezza 3 bar / Maximum pressure valve 3 Bar / Sicherheitsventil 3 Bar / Soupape de pression maximale 3 Bar / Válvula máxima presión 3 Bar	32.00
2	41501205500	VALVOLA SFOGO ARIA / AIR VENT VALVE / ENTLÜFTUNGSVENTIL / SOUPAPE DÉGAGEMENT AIR / VÁLVULA SALIDA AIRE	0.00
2	41502002000	CIRCOLATORE WILO PARA 7SC / WATER CIRCULATION PUMP WILO PARA 7S C / UMWÄLZPUMPE WILO PARA 7SC / POMPE DE CIRCULATION WILO PARA 7SC / BOMBA DE CIRCULACIÓN AGUA WILO PARA 7SC	0.00
2	41501103500	SCAMBIATORE SANITARIO 14 PIASTRE / HEAT EXCHANGER 14 PLATES / WÄRMETAUSCHER 14 PLATTEN / ÉCHANGEUR SANITAIRE 14 PLAQUES / INTERCAMBIADOR SANITARIO 14 PLACAS	0.00
2	41501205800	FLUSSOSTATO / WATER FLOW SENSOR / FLUSSWÄCHTER / FLUXOSTAT / FLUJOSTATO	0.00
3	41501203100	Tubo collegamento circolatore - con circolatore alta efficienza / Pump connection tube - with high efficiency circulation pump / Verbindungsrohr zur Pumpe - mit Hochleistungs-Zirkulator / Tuyau de connection à la pompe - avec circulateur à haut rendement / Tubo de conexión a la bomba - con bomba alto rendimiento	25.00
4	41501200900	Tubo collegamento ritorno riscaldamento / Heating connection water return tube / Heizung Verbindungsrücklaufrohr / Tuyau de connection retour eau chauffage / Tubo de conexión regreso agua calentamiento	39.00
5	4120775	Vaso espansione (6 l) / Expansion vessel (6 l) / Expansionsgefäß (6 l) / Vase d'expansion (6 l) / Vaso de expansión	75.00

		(6 l)	
6	41501100800	Tubo di mandata acqua da caldaia / Boiler water delivery tube / Vorlaufrohr Wasser vom Kessel / Tuyau de refoulement eau de la chaudière / Tubo de envío de agua de la caldera	34.00
7	41501100901	Manometro / Manometer / Manometer / Manomètre / Manómetro	42.00
8	4120779	Valvola di sfiato / Vent valve / Entlüftungsventil / Soupape de dégagement / Válvula respiradero	26.00