

## IBIS 22 KW H2O

Componenti Struttura Esterna / External structure components / Bauteile Aussenkorpus / Composants structure externe / Componentes estructura externa

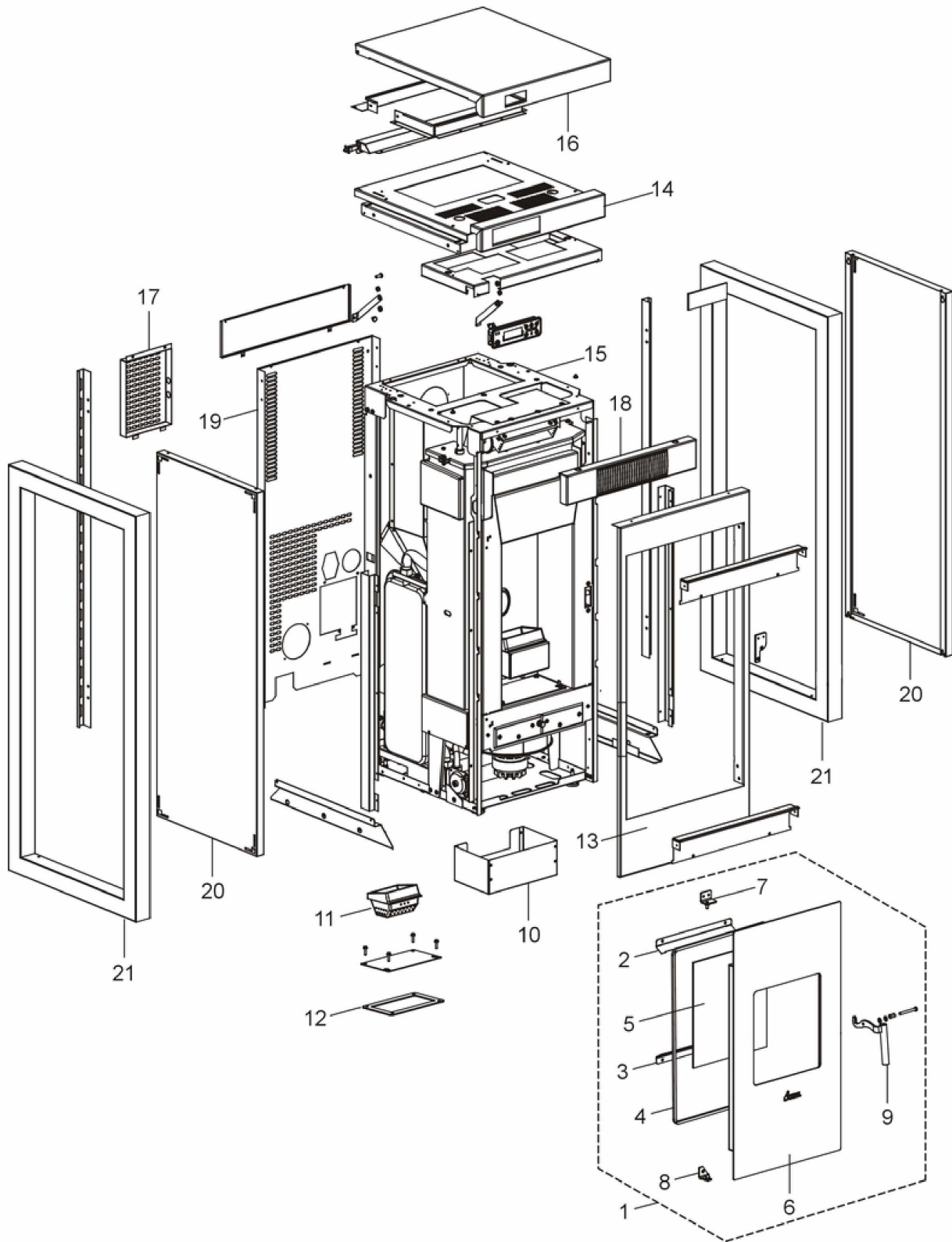

N°	Codice/Code	Descrizioni / Description / Beschreibung / Description / Description	Prezzo (€)
----	-------------	--	------------

1	4D245GP14008	Porta fuoco completa / Complete fire door / Komplette Feurtür / Porte foyer complète / Puerta hogar completa	210.00
2	4D242146013	Fermavetro superiore/inferiore / Upper/Lower pyroceram fastening bracket / Oberes/Unteres Befestigungsbügel Glaskeramik / Étrier supérieure/inférieure de fixation vitrocéramique / Abrazadera superior/inferior de fijación vidrio cerámico	20.00
3	4D242146013	Fermavetro superiore/inferiore / Upper/Lower pyroceram fastening bracket / Oberes/Unteres Befestigungsbügel Glaskeramik / Étrier supérieure/inférieure de fixation vitrocéramique / Abrazadera superior/inferior de fijación vidrio cerámico	20.00
4	4D18013021A	Guarnizione treccia nera D.10 - 5 M / Black twist gasket D.10 - 5 M / Dichtung D.10 - 5 M / Joint tresse noire D.10 - 5 M / Junta D.10 - 5 M	33.00
4	4D180146010	Guarnizione / Gasket / Dichtung / Joint / Junta	42.00
5	4D17013029	Vetroceramico 257x299x4 mm / Vitrocéramique 257x299x4 mm / Glasskeramik Scheibe 257x299x4 mm / Glass 257x299x4 mm / Cristal cerámico 257x299x4 mm	73.00
6	4D24014611461	Telaio porta fuoco / Fire door frame / Feuertürrahmen / Cadre porte foyer / Armazón puerta hogar	119.00
7	4D24014601361	Supporto superiore della porta / Upper door support / Oberes Türhaltebügel / Support supérieur de la porte / Soporte superior de la puerta	20.00
8	4D24014602361	Supporto inferiore della porta / Lower door support / Unteres Türhaltebügel / Support inférieur de la porte / Soporte inferior de la puerta	20.00
9	4D12013031	Maniglia / Handle / Griff / Poignée / Tirador	47.00
10	4D2401315418	Cassetto cenere / Ash drawer / Aschenkasten / Tiroir à cendres / Cajón ceniza	60.00
11	413008003	Braciere completo in ghisa / Cast iron complete grate / Kompletter Brenntopf aus Gusseisen / Brasero complet en fonte / Brasero completo de arrabio	67.00
11	4D242140053	Antiscoppio / Anti-explosion / Bausatz Überdruckablauf Brennkammer / Plaque Easy-Start / Anti-explosión	28.00
12	41800900600	Guarnizione / Gasket / Dichtung / Joint / Junta	21.00
13	4D24014621361	Telaio frontale / Frontal frame / Vorderes Rahmen / Cadre frontal / Armazón frontal	69.00
14	4D24014622363	Pannello frontale nero / Black frontal panel / Vorderes schwarze Paneel / Panneau antérieur noir / Panel frontal negro	59.00
15	41400907563	Supporto top / Top support / Deckelhaltebügel / Support du dessus / Soporte del top	47.00
16	4D24014623363	Coperchio serbatoio pellet / Pellet hopper cover / Deckel Pelletbehälter / Couvercle réservoir pellet / Tapadera depósito	47.00
17	4D2401315405	Coperchio scheda madre / Motherboard cover / Deckel Hauptplatine / Couvercle carte mère / Tapadera tarjeta madre	23.00
18	4D24014632463	Griglia frontale nera / Black frontal grille / Vordere schwarze Gitter / Grille frontale noire / Rejilla frontale negra	197.00
19	4D241146043	Schiena esterna / External back / Rückwand / Dossier extérieur / Parte trasera	61.00
20	4D24014628363	Fianco nero / Black side / Schwarze Seite / Côté noir / Lateral negro	68.00
20	4D24014628363	Fianco nero / Black side / Schwarze Seite / Côté noir / Lateral negro	68.00
21	6914005	Rivestimento completo Rosso / Complete Red cladding / Komplette Verkleidung Rot / Habillage complète Rouge / Revestimiento completo Rojo	190.00
21	6914006	Rivestimento completo Bianco / Complete White cladding / Komplette Verkleidung Weiß / Habillage complète Blanc / Revestimiento completo Blanco	190.00
21	6914007	Rivestimento completo Cromo / Complete Chrome cladding / Komplette Verkleidung Chrom / Habillage complète Chrome / Revestimiento completo Cromo	190.00
21	6914005	Rivestimento completo Rosso / Complete Red cladding / Komplette Verkleidung Rot / Habillage complète Rouge / Revestimiento completo Rojo	190.00
21	6914006	Rivestimento completo Bianco / Complete White cladding / Komplette Verkleidung Weiß / Habillage complète Blanc / Revestimiento completo Blanco	190.00
21	6914007	Rivestimento completo Cromo / Complete Chrome cladding / Komplette Verkleidung Chrom / Habillage complète Chrome / Revestimiento completo Cromo	190.00

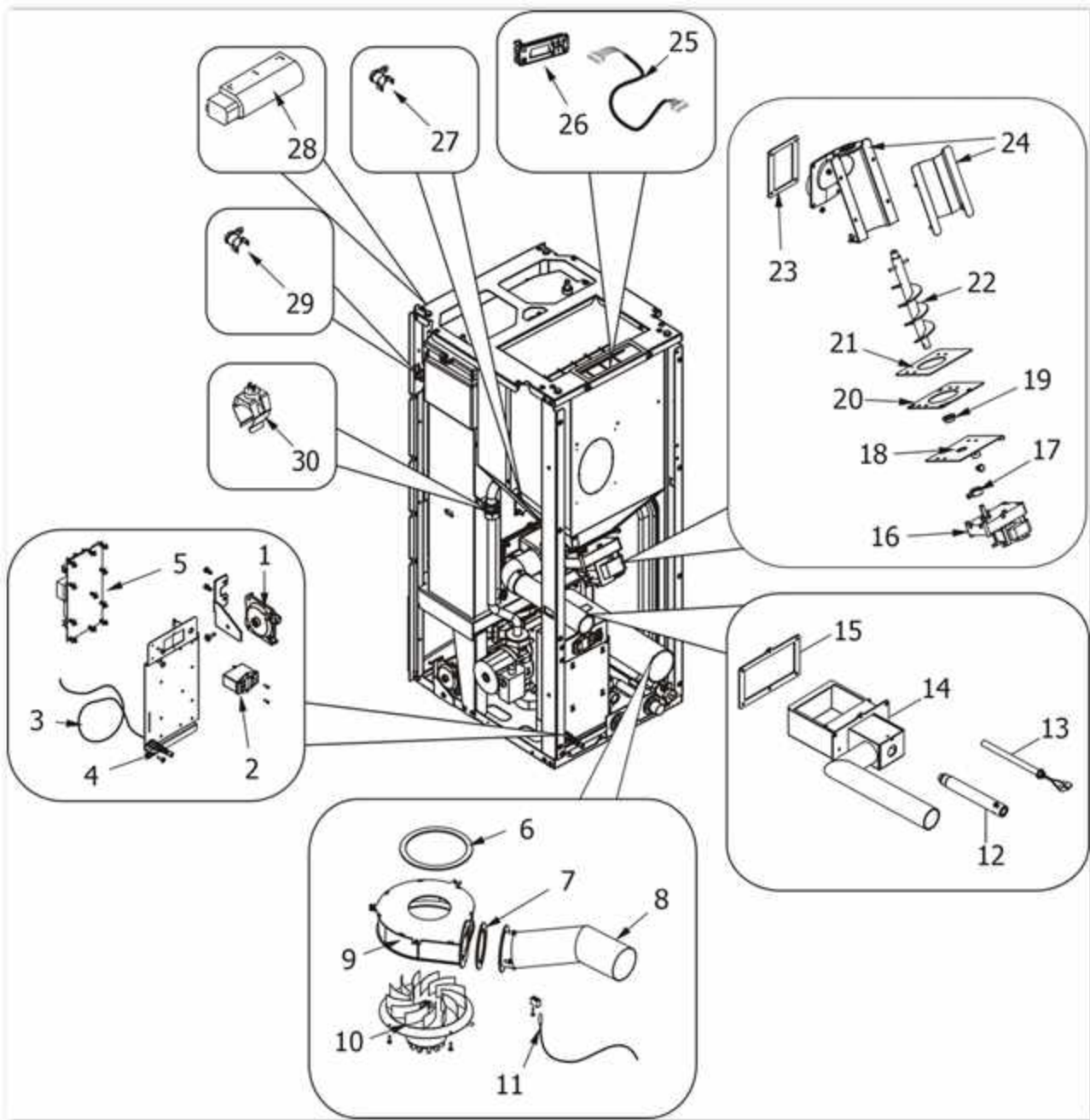

## IBIS 22 KW H2O

Componenti interni meccanici ed elettronici / Electronic and mechanic internal parts / Interne mechanische und elektronische Bauteile / Composants internes mécaniques et électroniques / Componentes internos electrónicos y mecánicos

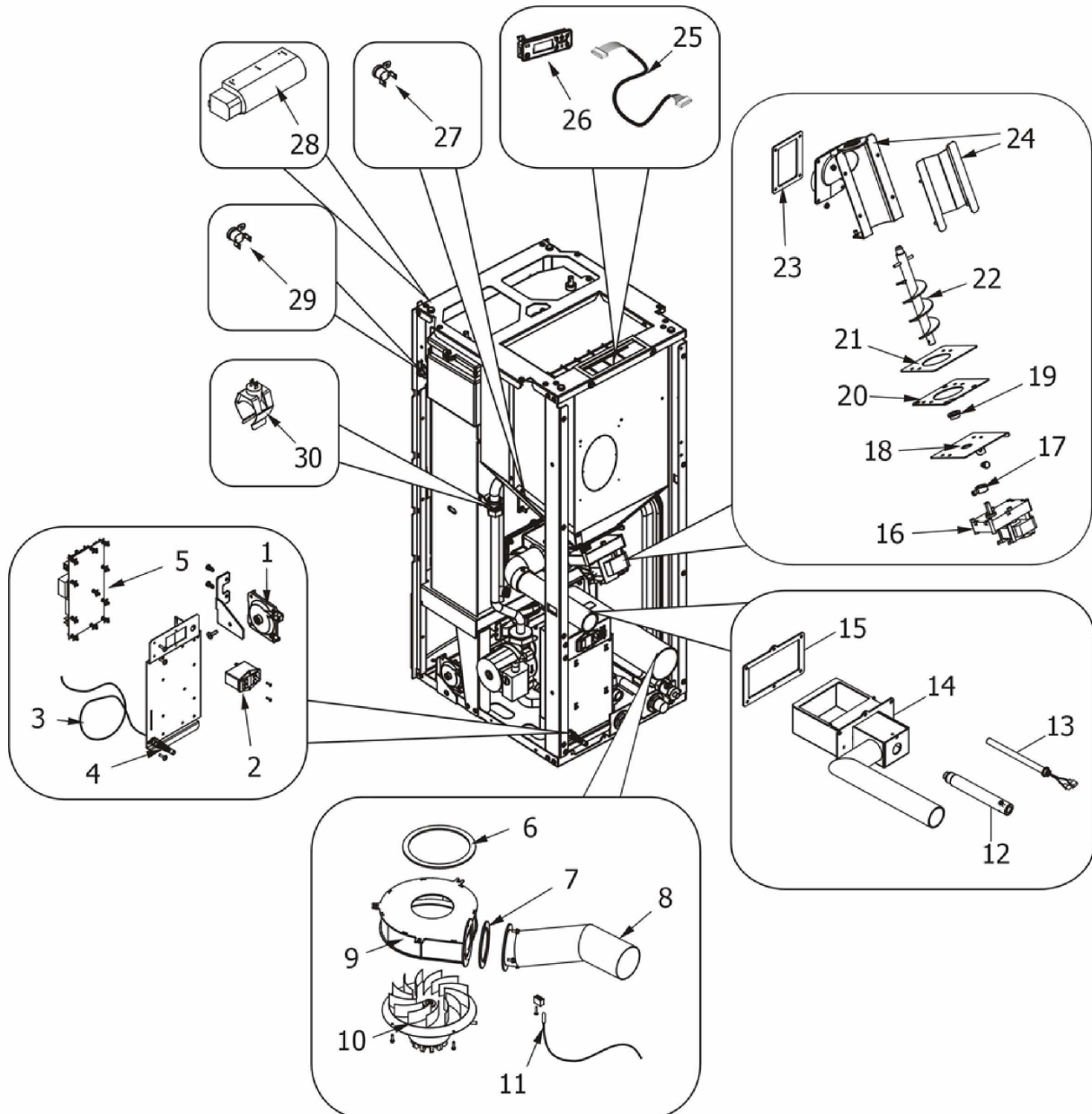

N°	Codice/Code	Descrizioni / Description / Beschreibung / Description / Descripción	Prezzo (€)
1	4160482	Pressostato 0,4 mbar / Pressure gauge 0,4 mbar / Druckschalter 0,4 mbar / Pressostat 0,4 mbar / Presostato 0,4 mbar	38.00
2	4160193	Pulsante accensione / On/Off button / Zündungstaste / Touche d'allumage / Botón encendido	28.00
3	4160386	Sonda temperatura ambiente/acqua / Room/Water temperature sensor / Raum- Wassertemperaturfühler / Sonde température ambiante/eau / Sonda temperatura ambiente/agua	21.00
4	414508038	Pressacavo / cable holder / Kabelklemme / presse-cable / presionacable	21.00
5	41451200500	Scheda madre completa MICRONOVA / Complete mother board MICRONOVA / Komplette Hauptplatine MICRONOVA / Carte mère complete MICRONOVA / Tarjeta madre completa MICRONOVA	239.00
6	41801002600	Guarnizione adesiva voluta fumi / Adhesive gasket smoke volute / Haftenddichtung Rauchvolute / Joint adhesive volute fumées / Junta adhesiva voluta humos	20.00
7	41801001700	Guarnizione / Gasket / Dichtung / Joint / Junta	22.00
8	41601001460	Tubo uscita fumi / Smoke outlet pipe / Rohr Rauchabzug / Tuyau sortie fumées / Tubo salida humos	55.00

9	41401042942	Voluta per ventilatore con encoder / Volute for fan with encoder / Volute für Gebläse mit Encoder / Volute pour ventilateur avec encoder / Voluta para ventilador con encoder	89.00
10	414508016	Ventilatore aspirazione fumi con encoder / Smoke exhaust fan WITH encoder / Rauchabsauggebläse MIT Encoder / Ventilateur aspiration fumées AVEC encoder / Ventilador aspiración humos con codificador	282.00
10	41801301500	Guarnizione adesiva SP 6 D210 / Adhesive Gasket SP 6 D210 / Haftenddichtung SP 6 D210 / Joint Adhesive SP 6 D210 / Junta Adhesiva SP 6 D210	20.00
11	4160239	Sonda temperatura fumi / Smoke temperature sensor / Rauchtemperaturfühler / Sonde température fumées / Sonda temperatura humos	27.00
12	41200903900	Condotto candeletta / Sparkplug conduit / Zündkerzenkanal / Conduit bougie / Conducto bujía	36.00
13	41450905000	Candeletta accensione pellet / Pellet ignition sparkplug / Zündkerze Pelletzündung / Bougie d'allumage pellet / Bujía encendido pellet	45.00
14	41401069141V	Tasca braciere / Combustion pot container / Brenntopfkasten / Récipient braséro / Contenedor brasero	164.00
15	418008027	Guarnizione / Gasket / Dichtung / Joint / Junta	22.00
16	41450901600	Motoriduttore 3,3 rpm Merkle Korff / Reduction motor 3,3 rpm Merkle Korff / Getriebemotor 3,3 RPM MERKLE KORFF / Motorréducteur 3,3 RPM MERKLE KORFF / Motorreductor 3,3 rpm Merkle Korff	114.00
17	4120398	Connettore motoriduttore-coclea / Reduction motor-feed screw connector / Verbindung Getriebemotor-Schnecke / Connecteur motorréducteur-vis sans fin / Conector motorreductor-cóclea	22.00
18	41400944351	Base della coclea / Feed screw base / Untergestell der Förderschnecke / Base de la vis sans fin / Base de la cóclea	25.00
19	4120614	Boccola grafitata (2 pz) / Etched bush (2 pcs) / Graphitbuchse (2 Stck) / Bride graphitée (2 pcs) / Brida grafitada (2 pz)	20.00
20	41400903310	Flangia condotto coclea / Base of feed screw conduit / Untergestell Rohrleitung der Förderschnecke / Base du conduit de la vis sans fin / Base de conducto de la cóclea	20.00
21	4120615	Guarnizione base della coclea / Feed screw base gasket / Dichtung Untergestell der Förderschnecke / Joint pour la base de la vis sans fin / Junta base de la cóclea	19.00
22	41200901040	Coclea di caricamento pellet / Pellet feed screw / Pelletsförderschnecke / Vis sans fin pour chargement du pellet / Cóclea de carga pellet	46.00
23	418008029	Guarnizione / Gasket / Dichtung / Joint / Junta	21.00
24	41401077540V	Condotto della coclea / Conduit of feed screw / Rohrleitung der Förderschnecke / Conduit de la vis sans fin / Conducto de la cóclea	81.00
25	41451201900	Cavo Flat L 1,4 M / Flat cable L 1,4 M / Flat Kable L 1,4 M / Câble Flat L 1,4 M / Cable Flat L 1,4 M	21.00
26	4D1451303300	Pannello comandi grafico / Graphic control panel / Graphische Bedienblende / Tableau de commande / Panel de mandos gráfico	138.00
27	412007004	Clickson 110°C / Clickson 110°C / Clickson 110°C / Clickson 110°C / Clickson 110°C	20.00
28	41451000300	Ventilatore scambiatore aria calda / Hot air exchanger fan / Wärmeluftgebläse / Ventilateur échangeur air chaud / Ventilador intercambiador aire caliente	55.00
29	41450901100	Clickson 95°C / Clickson 95°C / Clickson 95°C / Clickson 95°C / Clickson 95°C	20.00
30	41450901200	Sonda temperatura acqua / Water temperature sensor / Wassertemperaturfühler / Sonde température eau / Sonda temperatura agua	26.00

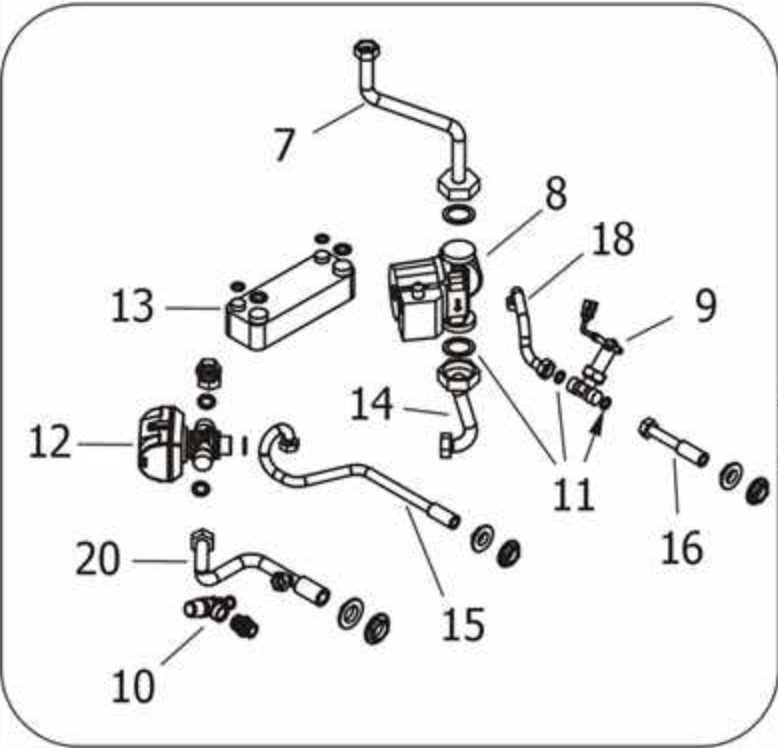
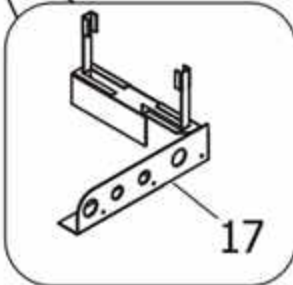
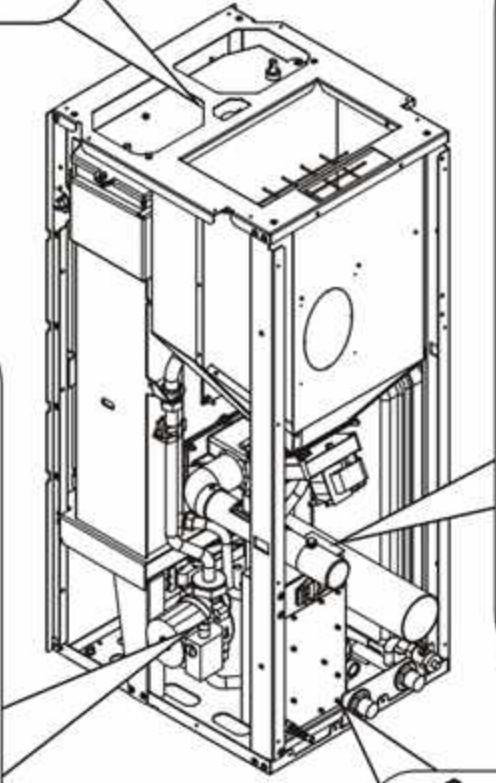
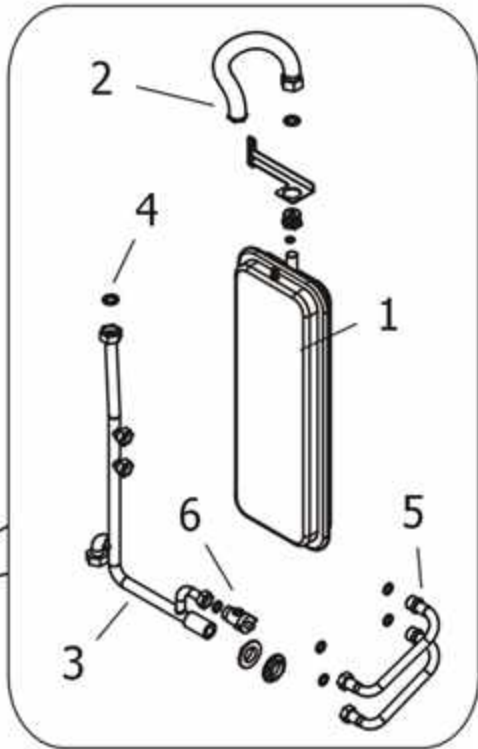
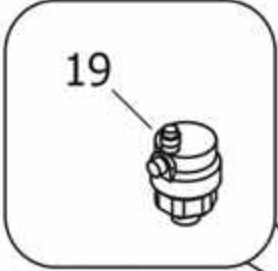

## IBIS 22 KW H2O

Componenti interni idraulici CON kit acqua sanitaria / Internal plumbing components WITH domestic water kit / Interne hydraulische Bauteile MIT Brauchwassersatz / Composants hydrauliques internes AVEC kit eau sanitaire / Componentes internos hidráulicos CON kit de agua sanitaria

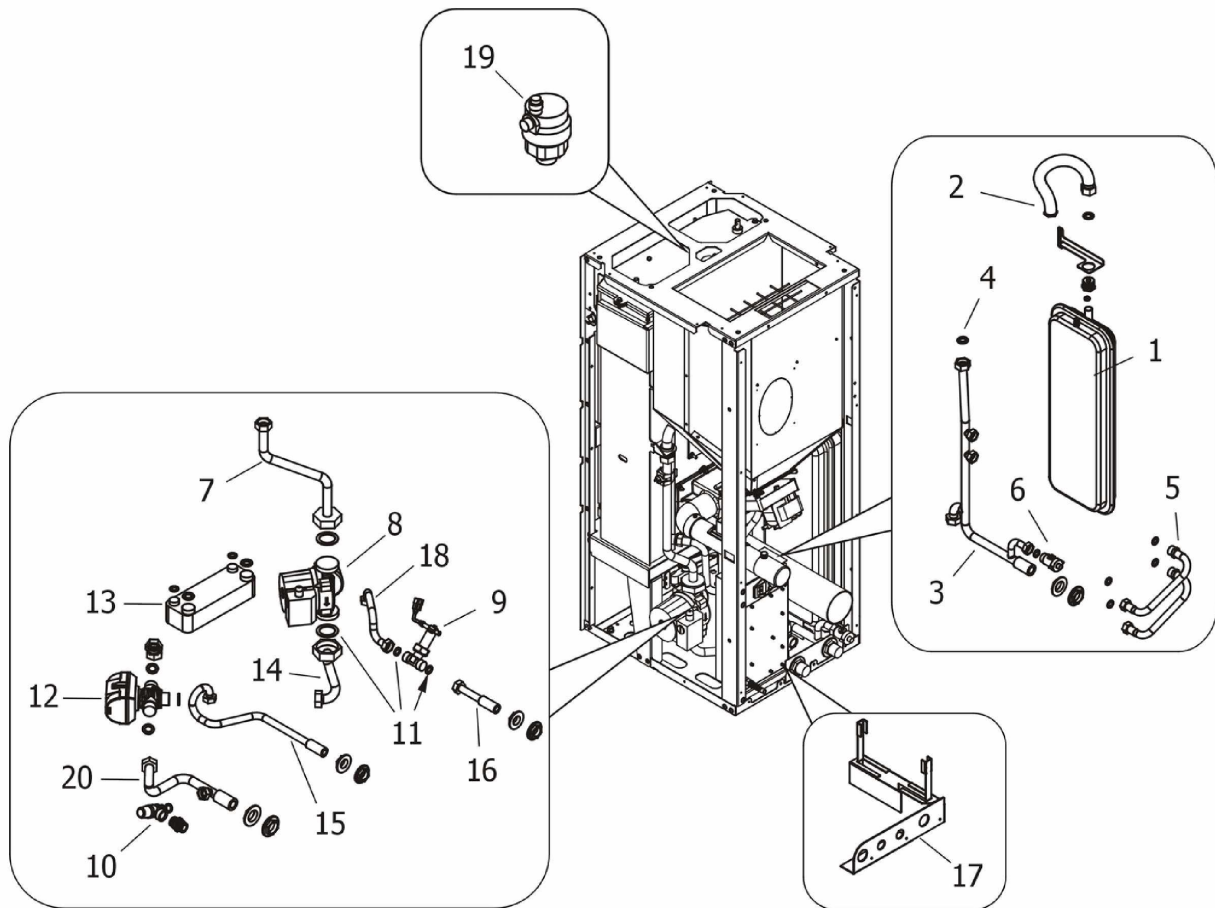

N°	Codice/Code	Descrizioni / Description / Beschreibung / Description / Descripción	Prezzo (€)
1	4120775	Vaso espansione (6 l) / Expansion vessel (6 l) / Expansionsgefäß (6 l) / Vase d'expansion (6 l) / Vaso de expansión (6 l)	75.00
2	4120781	Giunto estensibile inox ¾" / ¾" stainless steel flexible joint / Edelstahl Verbindungsschlauch ¾" / Joint flexible inox ¾" / junta flexible inox ¾"	48.00
3	41501002300	Tubo di ritorno acqua in caldaia / Boiler water return tube / Wasserrücklaufrohr zum Kessel / Tuyau retour eau dans la chaudière / Tubo de regreso agua a la caldera	57.00
4	41207910	Kit guarnizioni impianto idraulico / Hydraulic system gasket kit / Dichtungsbausatz für Hydraulikanlage / Kit de joints pour l'installation hydraulique / Kit de juntas de la instalación de fontanería	34.00
5	41500901300	Tubo flessibile inox 1/2" / 1/2" stainless steel flexible tube / Edelstahlschlauch 1/2" / Tuyau flexible inox 1/2" / Tubo flexible inox 1/2"	23.00
6	4160351	Rubinetto scarico ½" con tappo / ½" drain valve with plug / Ablaufhahn ½" mit Stopfen / Robinet évacuation ½" avec bouchon / Grifo de desagüe ½" con tapón	31.00
7	41501002400	Tubo di mandata acqua da caldaia / Boiler water delivery tube / Vorlaufrohr Wasser vom Kessel / Tuyau de refoulement eau de la chaudière / Tubo de envío de agua de la caldera	35.00
8	41501500100	Pompa alta efficienza / High efficiency pump / Hoch effizient Pumpe / Pompe de circulation haut rendement / Bomba circulación alto rendimiento	-
9	415008018	Flussostato / Flow switch / Strömungswächter / Fluxostat / Flujostato	82.00
10	4120778	Valvola di massima pressione (3 bar) / Maximum pressure valve (3 bar) / Hochdruckventil (3 Bar) / Soupape de pression maximale (3 bar) / Válvula de máxima presión (3 bar)	31.00
11	41207910	Kit guarnizioni impianto idraulico / Hydraulic system gasket kit / Dichtungsbausatz für Hydraulikanlage / Kit de joints pour l'installation hydraulique / Kit de juntas de la instalación de fontanería	34.00
12	41501001600	Valvola deviatrice a 3 vie / 3-way deviator valve / 3-Wegeumleitventil / Soupape de déviation à 3 voies / Válvula desviadora de 3 vías	203.00
13	415008017	Scambiatore a piastre / Plate heat exchanger / Plattenwärmetauscher / Échangeur à plaques / Intercambiador de	149.00



		placas	
<b>14</b>	<b>41501002000</b>	Tubo di mandata acqua da caldaia / Boiler water delivery tube / Vorlaufrohr Wasser vom Kessel / Tuyau de refoulement eau de la chaudière / Tubo de envío de agua de la caldera	<b>31.00</b>
<b>15</b>	<b>41501001900</b>	Tubo di mandata acqua sanitaria / Domestic hot water delivery tube / Vorlaufrohr Warmwasser / Tuyau de refoulement eau sanitaire / Tubo de envío de agua caliente	<b>37.00</b>
<b>16</b>	<b>41501002200</b>	Tubo ingresso acqua sanitaria / Domestic water inlet tube / Sănitărwasser Eingangrohr / Tuyau d'entré eau sanitaire / Tubo de entrada agua sanitaria	<b>27.00</b>
<b>17</b>	<b>41401069030</b>	Staffa di supporto gruppo idraulico / Hydraulic group support bracket / Haltebügel der Hydraulischen Baugruppe / Étrier support du group hydraulic / Zuncho de soporte del kit idraulico	<b>30.00</b>
<b>18</b>	<b>41501500100</b>	Pompa alta efficienza / High efficiency pump / Hoch effizientz Pumpe / Pompe de circulation haut rendement / Bomba circulación alto rendimiento	-
<b>19</b>	<b>4120779</b>	Valvola di sfıato / Vent valve / Entlüftungsventil / Soupape de dégagement / Válvula respiradero	<b>26.00</b>
<b>20</b>	<b>41501001800</b>	Tubo di mandata / Water delivery tube / Vorlaufrohr Wasser / Tuyau de refoulement / Tubo de envío de agua	<b>87.00</b>

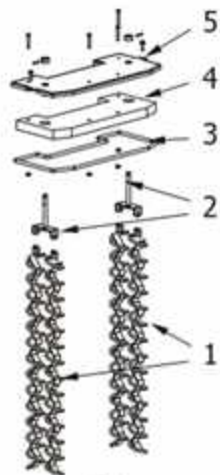

## IBIS 22 KW H2O

Gruppo scambiatore / Exchanger group / Austausch Baugruppe / Groupe échangeur / Grupo intercambiador

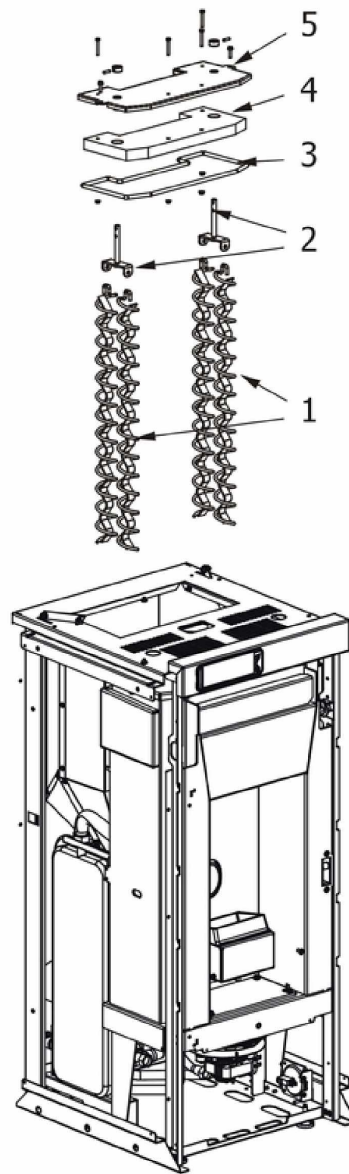

N°	Codice/Code	Descrizioni / Description / Beschreibung / Description / Descripción	Prezzo (€)
1	41200903100	Eliche raschiatore (1 pz.) / Turbulator props (1 pc.) / Reinigungsspirale (1 Teil) / Hélices turbulateur (1 pz.) / Hélice rascador (1 pz.)	27.00
2	41400914740	Staffa sostegno raschiatore / Turbulator support bar / Haltebügel der Reinigungsspirale / étrier support turbulateur / Zuncho apoyo rascador	25.00

<b>3</b>	<b>4D18013021A</b>	Guarnizione treccia nera D.10 - 5 M / Black twist gasket D.10 - 5 M / Dichtung D.10 - 5 M / Joint tresse noire D.10 - 5 M / Junta D.10 - 5 M	<b>33.00</b>
<b>4</b>	<b>41150900100</b>	Pannello calorite coperchio caldaia / Boiler cover calorite panel / Kesseldeckepaneel aus Calorite / Panneau en calorite couvercle chaudière / Panel en calorite tapa caldera	<b>29.00</b>
<b>5</b>	<b>41400914840V</b>	Coperchio scambiatore / Exchanger cover / Deckel des Austauschers / Couvercle Echangeur / Tapa intercambiador	<b>55.00</b>