

EVO3 - 8,5KW

Componenti Struttura Esterna / External structure components / Bauteile Aussenkorpus / Composants structure externe / Componentes estructura externa

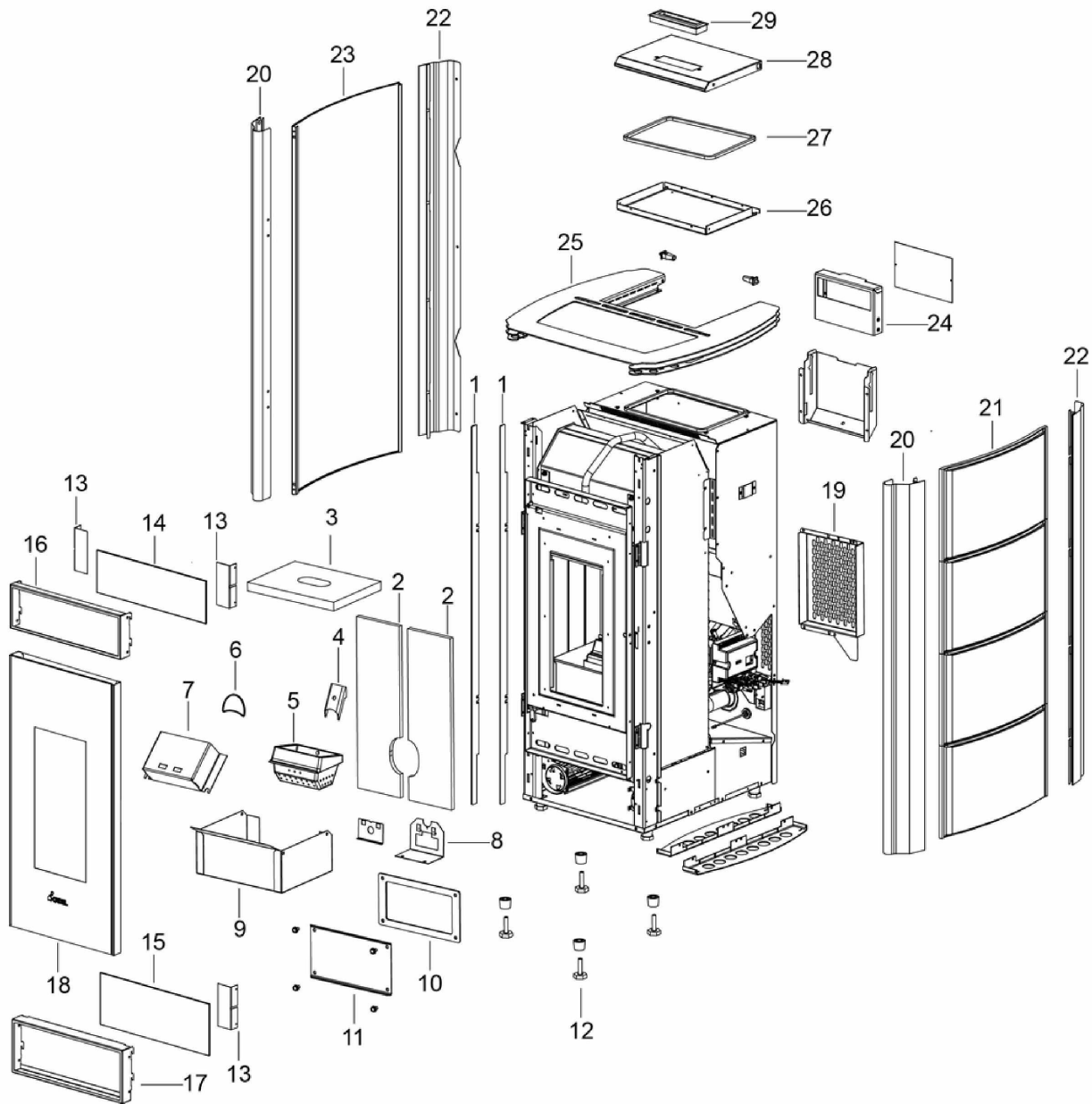

N°	Codice/Code	Descrizioni / Description / Beschreibung / Description / Descripción	Prezzo (€)
1	4D242157071	Profilo DX/SX inox frontale / L.-R. front profile inox / Frontprofil RE/LI Inox / Profil frontal gauche/droite inox / IZDO-DCHO perfil frontal inox	48.00
1	4D242157071	Profilo DX/SX inox frontale / L.-R. front profile inox / Frontprofil RE/LI Inox / Profil frontal gauche/droite inox / IZDO-DCHO perfil frontal inox	48.00
2	4D115157040	Schiena Vermiculite (2 pz.) / Vermiculite back (2 pcs.) / Rückwand aus Vermiculite (2 Stck.) / Fond en Vermiculite (2 pcs.) / Parte trasera de Vermiculite (2 pzs.)	50.00
2	4D115157040	Schiena Vermiculite (2 pz.) / Vermiculite back (2 pcs.) / Rückwand aus Vermiculite (2 Stck.) / Fond en Vermiculite (2 pcs.) / Parte trasera de Vermiculite (2 pzs.)	50.00
2	41451209300	Encoder per ventilatore fumi marchi LN2/SIT / Encoder for LN2/SIT smoke fan / Encoder für LN2/SIT Rauchgasgebläse / Encoder pour ventilateur des fumées marques LN2/SIT / Encoder para ventilador humos marcas LN2/SIT	21.00
3	4D115157020	Deflettore vermiculite superiore / Upper vermiculite deflector / Obere leitblech aus Vermiculite / Deflecteur vermiculite superieur / Deflector en vermiculite superior	42.00
4	4D242140053	Antiscoppio / Anti-explosion / Bausatz Überdruckablauf Brennkammer / Plaquette Easy-Start / Anti-explosión	28.00

5	413008003	Braciere completo in ghisa / Cast iron complete grate / Kompletter Brennertopf aus Gusseisen / Brasero complet en fonte / Brasero completo de arrabio	67.00
5	4D13016602061	Braciere / Grate / Brennschale / Brasero / Brasero	62.00
6	4D2401303101	Deflettore pellet / Pellet deflector / Pellet Leitblech / Deflecteur pellet / Deflector pellet	34.00
7	4D24015747361	Deviatore fumi nero 500° / Black Smoke Conveyor 500° / Schutzblech Abgasgebläse schwarz 500° / Deviateur fumée noir 500° / Conductor De Humos Negro 500°	43.00
8	4D242157153	Farfalla automatica / Air Flux Regulator / Clapet Ventil - Luftflussregler / Volet automatique / Regulador Flujo Aire	41.00
9	4D24015728461	Cassetto cenere nero / Ash drawer / Aschenkasten schwarz / Tiroir à cendres noir / Cajón ceniza	100.00
10	41800900600	Guarnizione / Gasket / Dichtung / Joint / Junta	21.00
11	4D24015762361	Chiusura fumi nera / Smoke Compartment Inspection Plug / Schwarze Inspektionsklappe Rauchabzug / Fermeture fumée noir / Tapón Inspección Compartim.Humos	29.00
12	4D12013006	Piedini di appoggio (4 pz.) / Support feet (4 pcs.) / Einstellfüße (4 Stck.) / Vérins (4 pcs) / Pies de apoyo (4 pzs)	25.00
13	4D241157193	Supporto vetro / Glass support / Scheibenrahmen / Support Vitre / Soporte cristal	25.00
13	4D241157193	Supporto vetro / Glass support / Scheibenrahmen / Support Vitre / Soporte cristal	25.00
13	4D241157193	Supporto vetro / Glass support / Scheibenrahmen / Support Vitre / Soporte cristal	25.00
14	4D170157020	Vetro superiore Evo / Upper glass Evo / Obere Glasscheibe Evo / Vitre inferieur / Cristal superior Evo	44.00
15	4D170157010	Vetro inferiore Evo / Lower glass Evo / Untere Glasscheibe Evo / Joint 130x80 mm / Cristal inferior Evo	69.00
16	4D24015749361	Pannello frontale superiore / Frontal upper panel / Oberes Frontpaneel / Panneau frontal supérieur / Panel frontal superior	46.00
17	4D24015748363	Pannello frontale inferiore / Frontal lower panel / Unteres Frontpaneel / Panneau frontal inférieur / Panel frontal inferior	45.00
18	4D245GP14004	Porta fuoco completa / Complete fire door / Komplette Feuertür / Porte foyer complète / Puerta hogar completa	319.00
18	4D24015841361	Kit decompressione camera di combustione / Pressure relief kit / Bausatz Überdruckablauf Brennkammer / Kit decompression chambre de combustion / Kit decompression cámara de combustión	32.00
19	4D241157123	Carter ispezione posteriore / Rear Casing / Hintere Inspektionskurbelgehäuse / Dossieret inspection posterieur / Carter Trasero	42.00
20	4D24015754363	Binario anteriore maioliche / Frontal ceramic rod / Vordere Montageleiste Kachel / Voie antérieur ceramiques / Montante anterior cerámica	66.00
20	4D24015754363	Binario anteriore maioliche / Frontal ceramic rod / Vordere Montageleiste Kachel / Voie antérieur ceramiques / Montante anterior cerámica	66.00
21	4D12512031	Ceramica laterale rosso / Red side ceramic / Seitliche Keramik Rot / Céramique latérale rouge / Cerámica lateral rojo	-
21	4D12512032	Ceramica laterale avorio / Ivory side ceramic / Seitliche Keramik Elfenbein / Céramique latérale ivoire / Cerámica lateral marfil	-
21	4D12512033	Ceramica laterale nero brillante / Sparkling black side ceramic / Seitliche Keramik glänzend Schwarz / Céramique latérale noire brillante / Cerámica lateral negro brillante	-
21	4D12513040	Pietra laterale serpentino / Lateral soapstone / Seitliche Stein aus Serpentino / Pierre latérale serpentine / Piedra lateral en Serpentino	-
21	4D12514004025	Pietra laterale bianca / White lateral stone / Seitenstein Weiss / Pierre latérale Blanche / Piedra lateral Blanca	-
22	4D24015755363	Binario posteriore maioliche / Rear ceramic rod / Hintere Montageleiste Kachel / Voie posterieur ceramiques / Montante posterior cerámica	53.00
22	4D24015755363	Binario posteriore maioliche / Rear ceramic rod / Hintere Montageleiste Kachel / Voie posterieur ceramiques / Montante posterior cerámica	53.00
23	6913007	Rivestimento metallo Silver / Silver metal cladding / Verkleidung aus Metall Silber / Habillage métal Silver / Revestimiento metal Silver	-
23	6913008	Rivestimento metallo Antracite / Charcoal metal cladding / Verkleidung aus Metall Anthrazit / Habillage métal Antracite / Revestimiento metal Antracita	88.50
23	6913009	Rivestimento metallo Rosso / Red metal cladding / Verkleidung aus Metall Rot / Habillage métal Rouge / Revestimiento metal Rojo	88.50
23	6913010	Rivestimento metallo Avorio / Ivory metal cladding / Verkleidung aus Metall Elfenbein / Habillage métal Ivoire / Revestimiento metal Marfil	-
23	6915018	Rivestimento completo metallo Light bronze / Complete Light bronze metal cladding / Komplette Verkleidung Metall Light bronze / Habillage complète métal Light Bronze / Revestimiento completo metal Light bronze	119.00
24	4D24015765363	Porta display 64K nero / Display support 64K black / Displayträger 64K schwarz / Support tableau de commande 64K noir / Soporte panel de mandos 64K negro	53.00
25	4D24015760461	Top nero 500° / Black top 500° / Schwarzes Topplatte 500° / Dessus noir 500° / Top negro 500°	171.00
26	4D241157093	Supporto / Support / Haltebügel / Support / Soporte	45.00
27	4D18013016	Guarnizione 155X190 mm / Gasket 155X190 mm / Dichtung 155x190 mm / Joint 155X190 mm / Junta 155X190 mm	34.00
28	4D24015730363	Coperchio serbatoio pellet nero / Pellet hopper cover (black) / Deckel Pelletbehälter schwarz / Couvercle réservoir	48.00

		pellet noir / Tapadera depósito pellet negro	
29	4D12013068	Maniglia coperchio / Cover handle / Deckel Griff / Poignée couvercle / Tirador tapadera	35.00
30	4D241157253	Supporto pannello comandi / Display support / Display halterung / Support pour le panneau de comande / Soporte panel de mandos	50.00

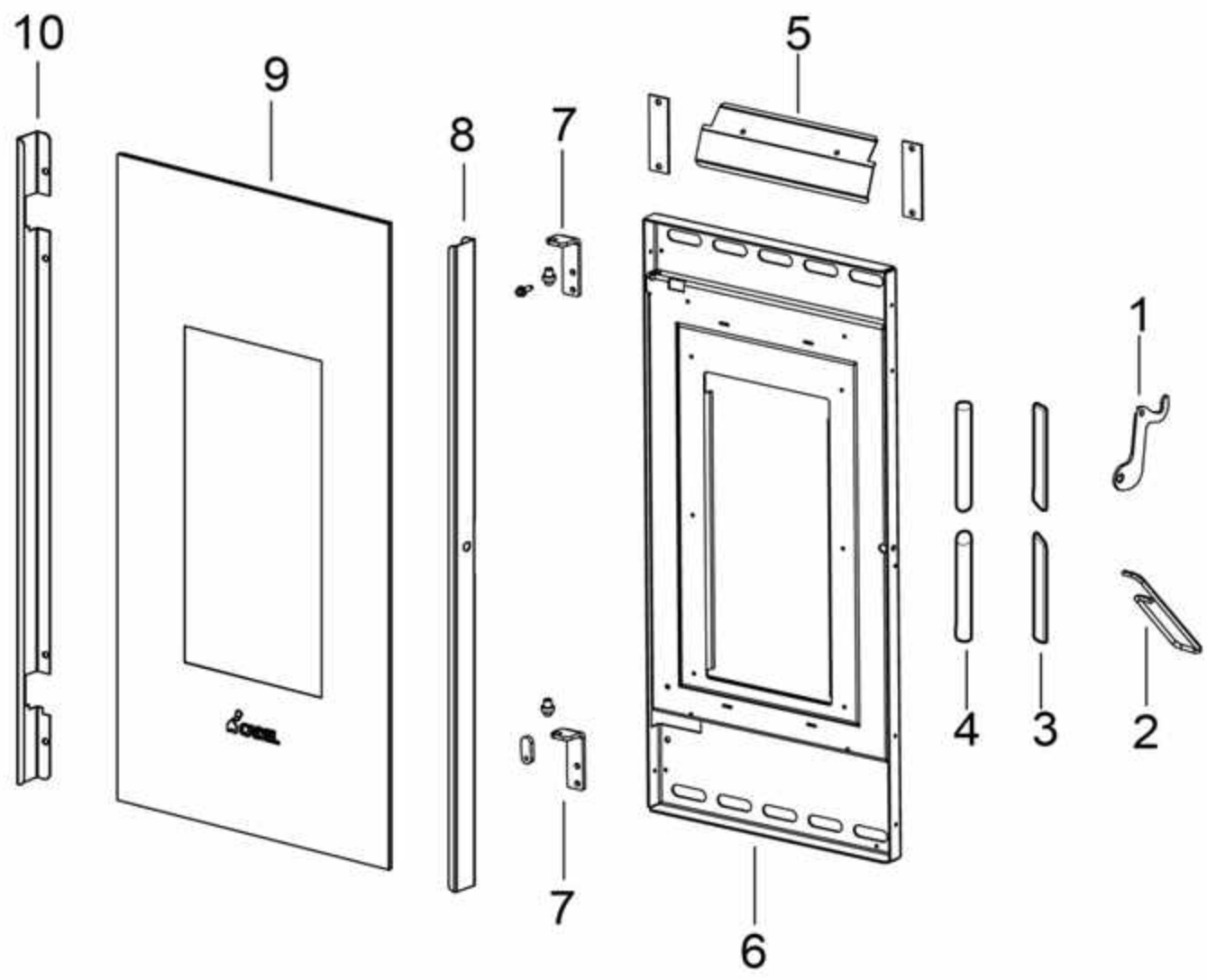

EVO3 - 8,5KW

Porta fuoco / Fire door / Feuertür / Porte foyer / Puerta hogar

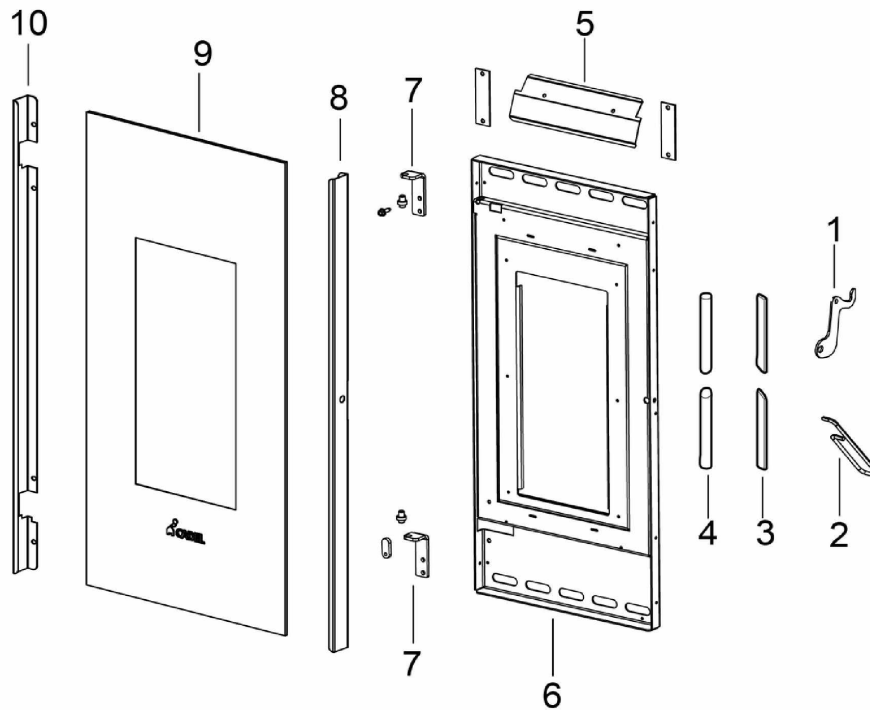

N°	Codice/Code	Descrizioni / Description / Beschreibung / Description / Descripción	Prezzo (€)
1	4D24014066161	Maniglia / Handle / Griff / Poignée / Tirador	23.00
1	4D24015841361	Kit decompressione camera di combustione / Pressure relief kit / Bausatz Überdruckablauf Brennkammer / Kit decompression chambre de combustion / Kit decompression cámara de combustión	32.00
2	4D12013060	Gancio "Mano fredda" / Hook "Cold hand" / Haken "Kalte Hand" / Crochet "Main froide" / Gancho "mano fría"	21.00
3	4D18013039A	Guarnizione a nastro (5 m) / Door strip gasket (5 m) / Türbanddichtung (5 m) / Joint vitre 25x3N5M / Guarnición cinta puerta (5m)	43.00
3	4D18013039B	Guarnizione a nastro (50 m) / Door strip gasket (50 m) / Türbanddichtung (50 m) / Joint vitre 25x3N50M / Guarnición cinta puerta (50m)	144.00
4	4D18013021A	Guarnizione treccia nera D.10 - 5 M / Black twist gasket D.10 - 5 M / Dichtung D.10 - 5 M / Joint tresse noire D.10 - 5 M / Junta D.10 - 5 M	33.00
4	4D18013021B	Guarnizione treccia nera D.10 - 50 M / Black twist gasket D.10 - 50 M / Dichtung D.10 - 50 M / Joint tresse noire D.10 - 50 M / Junta D.10 - 50 M	144.00
5	4D242157093	Deflettore aria porta / Door air deflector / Luftleitblech Tür / Deflecteur air porte / Deflector aire puerta	29.00
6	4D24014064461	Telaio porta fuoco / Fire door frame / Feuertürrahmen / Cadre porte foyer / Armazón puerta hogar	122.00
7	4D24015703361	Cerniere porta (2 pz) / Door hinges (2 pc.) / Tür Scharnier (2 Teile) / Charnières porte (2. pcs.) / Bisagras puerta (2 pz.)	35.00
7	4D24015703361	Cerniere porta (2 pz) / Door hinges (2 pc.) / Tür Scharnier (2 Teile) / Charnières porte (2. pcs.) / Bisagras puerta (2 pz.)	35.00
8	4D24014043361	Fermavetro DX Nero / R. Black Glass frame / R. Schwarze Haltebügel für Scheibenbefestigung / Étrier droite de fixation vitrocéramique / Retendor del cristal DCHO Negro	39.00
9	4D170140040	Vetroceramico 308x668x4 mm / Glass 308x668x4 mm / Glasskeramikscheibe 308x668x4 mm / Vitrocéramique 308x668x4 mm / Cristal cerámico 308x668x4 mm	173.00
10	4D24014042361	Fermavetro SX Nero / L. Black Glass frame / L. Schwarze Haltebügel für Scheibenbefestigung / Étrier gauche de fixation vitrocéramique / Retendor del cristal IZDO Negro	39.00

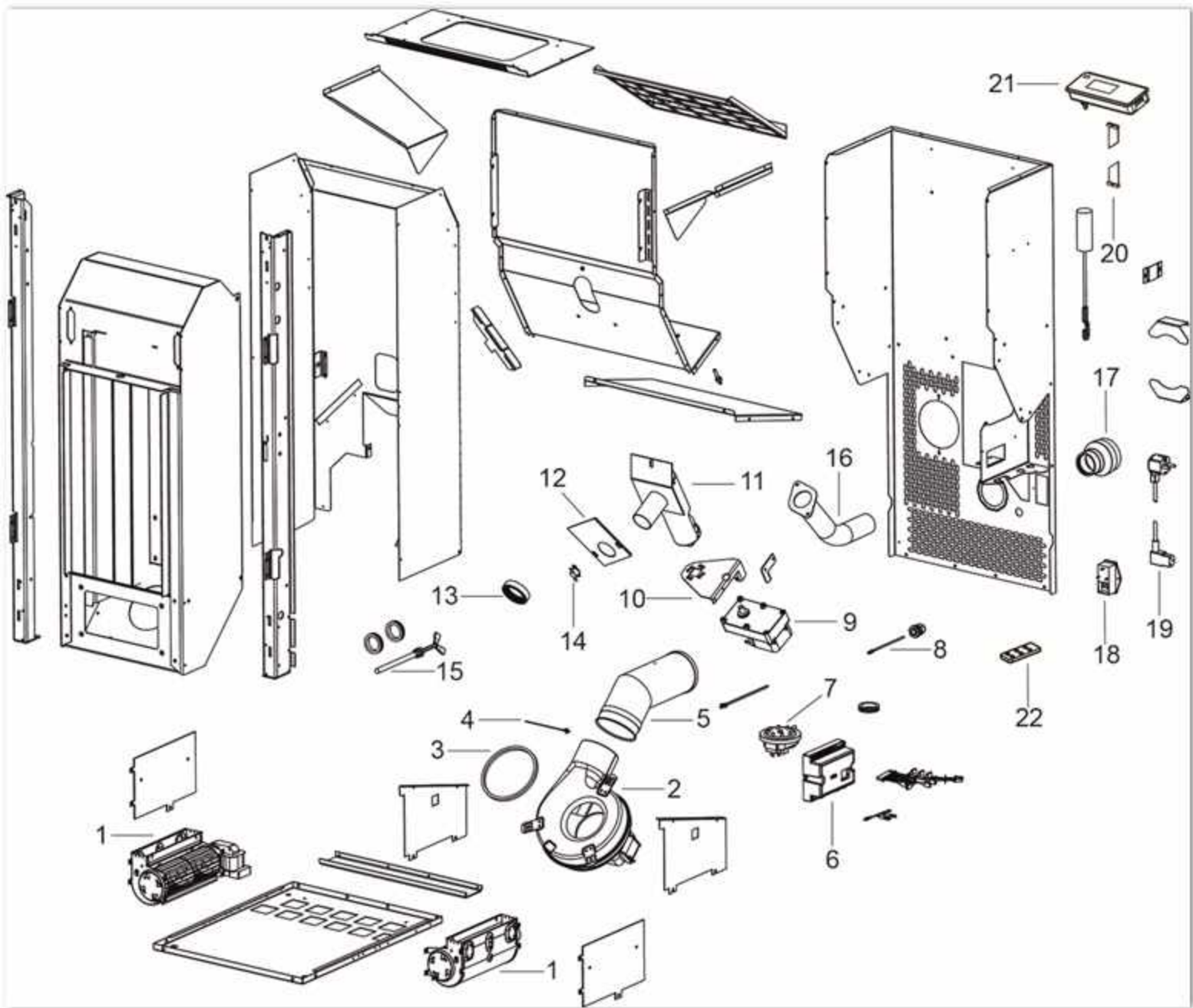

EVO3 - 8,5KW

Componenti interni meccanici ed elettronici / Electronic and mechanic internal parts / Interne mechanische und elektronische Bauteile / Composants internes mécaniques et électroniques / Componentes internos electrónicos y mecánicos

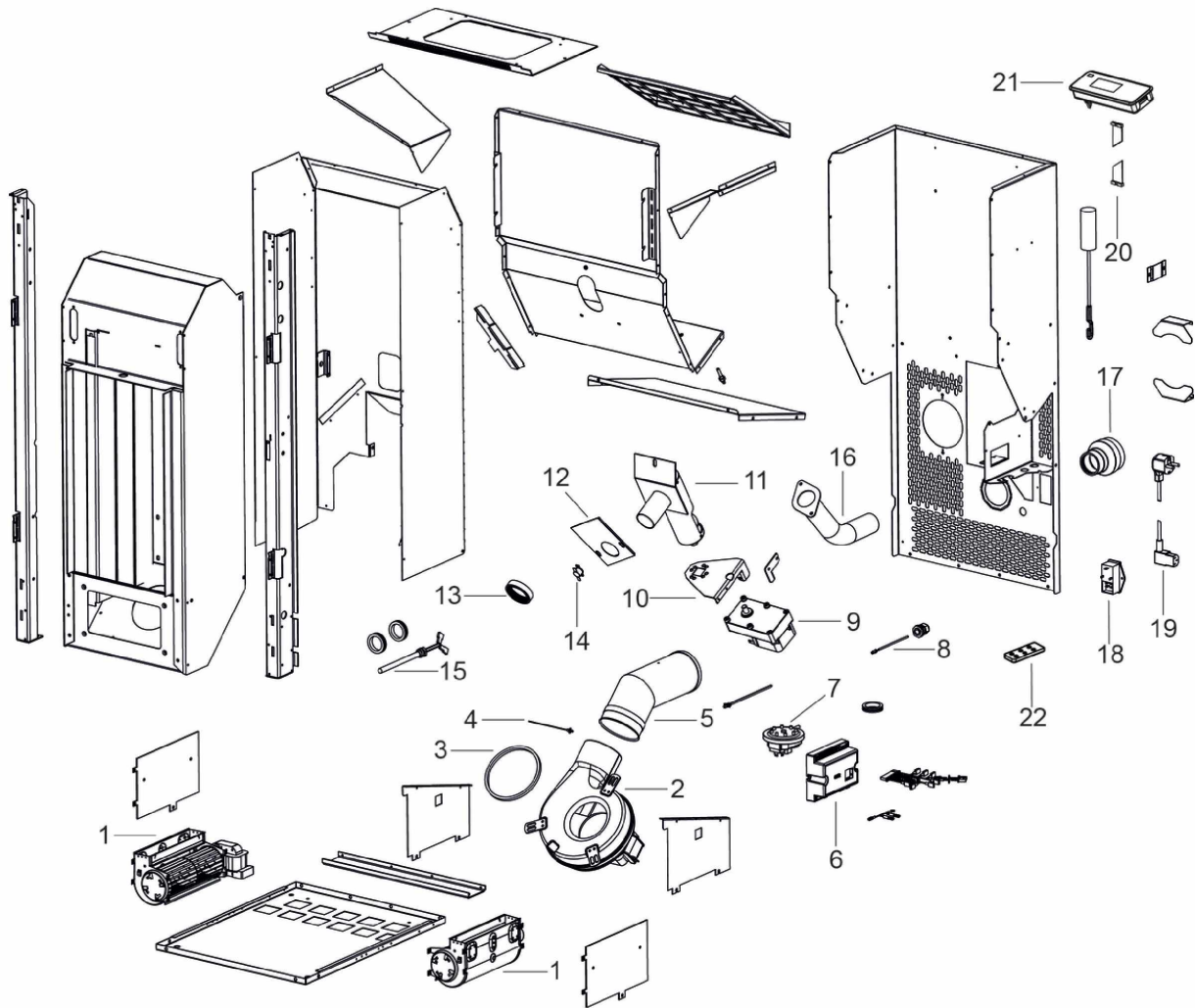

N°	Codice/Code	Descrizioni / Description / Beschreibung / Description / Descripcion	Prezzo (€)
1	4D145157030	Ventilatore aria / Air fan / Warmluftgebläse / Ventilateur air / Ventilador aire	75.00
1	4D145157040	Ventilatore aria / Air fan / Warmluftgebläse / Ventilateur air / Ventilador aire	75.00
2	4D145140150	Ventilatore fumi stagno / Air-tight smoke exhausted fan / Luftdichtes Rauchgasgebläse / Ventilateur fumées étanche / Ventilador humos hermético	121.00
2	41801600800	Guarnizione ventilatore fumi / Smoke exhaust fan gasket / Dichtung Rauchabsauggebläse / Joint Ventilateur aspiration fumées / Junta ventilador aspiración humos	22.00
2	41451209300	Encoder per ventilatore fumi marchi LN2/SIT / Encoder for LN2/SIT smoke fan / Encoder für LN2/SIT Rauchgasgebläse / Encoder pour ventilateur des fumées marques LN2/SIT / Encoder para ventilador humos marcas LN2/SIT	21.00
3	4D18013024	Guarnizione / Gasket / Dichtung / Joint / Junta	26.00
4	4D145150060	Sonda fumi / Smoke sensor / Rauchsonde / Sonde fumées / Sonda humos	30.00
5	4D160157030	Tubo 45° / 45° pipe / Rohr 45° / Tuyau 45° / Tubo 45°	52.00
6	4D145157020	Scheda madre N100 / Motherboard N100 / Hauptplatine N100 / Carte mère N100 / Tarjeta madre N100	155.00
6	4D145157020A	Scheda madre N10064K / Motherboard N10064K / Hauptplatine N10064K / Carte mère N10064K / Tarjeta madre N10064K	155.00
7	4160482	Pressostato 0,4 mbar / Pressure gauge 0,4 mbar / Druckwächter 0,4 mbar / Pressostat 0,4 mbar / Presostato 0,4 mbar	38.00
8	4D145150100	Sonda ambiente / Room temperature sensor / Raumtemperaturfühler / Sonde température ambiance / Sonda ambiente	24.00

9	4D145159010	Motoriduttore 3,3 rpm / Reduction motor 3,3 rpm / Getriebemotor 3,3 rpm / Motoréducteur 3,3 rpm / Motorreductor 3,3 rpm	120.00
9	4160278	Motoriduttore 1,5 RPM / Reduction motor 1,5 RPM / Getriebemotor 1,5 RPM / Motoréducteur 1,5 RPM / Motorreductor 1,5 RPM	103.00
10	4D2401302613	Supporto coclea / Feed screw support / Schnecke Halterung / Support de la vis-sans-fin / Soporte cóclea	37.00
11	4D140160030	Coclea di caricamento pellet / Pellet feed screw / Pelletsförderschnecke / Vis sans fin pour chargement du pellet / Cóclea de carga pellet	163.00
11	4D180177070	Coclea di caricamento pellet / Pellet feed screw / Pelletsförderschnecke / Vis sans fin pour chargement du pellet / Cóclea de carga pellet	141.00
11	4D180177010	Boccola / Bushing / Buchse / Douille / Abrazadera	23.00
12	4D18013004	Guarnizione 100X108 mm / Gasket 100X108 mm / Dichtung 100x108 mm / Joint 100X108 mm / Junta 100X108 mm	28.00
13	4D18013003	Guarnizione D.50 mm / Gasket D.50 mm / Dichtung D.50 mm / Joint D.50 mm / Junta D.50 mm	26.00
14	4D14513006	Termostato 60°C / Thermostat 60°C / Thermostat 60°C / Thermostat 60°C / Termostato 60°C	48.00
15	4D14513002	Candeletta / Sparkplug / Zündkerze Pelletzündung / Bougie / Bujía encendido pellet	50.00
15	4D145181040	Candeletta / Sparkplug / Zündkerze / Bougie / Bujía	51.00
16	4D160157050	Tubo ingresso aria / Air inlet pipe / Lufteingangsrohr / Tuyau entrée air / Tubo entrada aire	37.00
17	4D180150030	Raccordo / Connector / Anschlußrohr / Raccord / Racor	24.00
18	4160193	Pulsante accensione / On/Off button / Zündungstaste / Touche d'allumage / Botón encendido	28.00
18	4D145181080	Pulsante accensione 30.5x50 mm / On/Off button 30.5x50 mm / Zündungstaste 30.5x50 mm / Touche d'allumage 30.5x50 mm / Botón encendido 30.5x50 mm	18.00
19	4D14513041	Cavo alimentazione / Power source cable / Zündungskabel / Câble alimentation / Cable alimentación	25.00
20	4D14513031	Cavo flat scheda-pannello / Flat cable motherboard-control panel / Flat Kabel Hauptplatine-Bedienblende / Câble flat carte mère-panneau commande / Cable flat tarjeta madre-panel de mandos	36.00
21	4D1451303300	Pannello comandi grafico / Graphic control panel / Graphische Bedienblende / Tableau de commande / Panel de mandos gráfico	138.00
22	5019012	Telecomando / Remote control / Fernbedienung / Télécommande / Mando a distancia	55.00