

AURON

Componenti interni meccanici ed elettronici / Electronic and mechanic internal parts / Interne mechanische und elektronische Bauteile / Composants internes mécaniques et électroniques / Componentes internos electrónicos y mecánicos

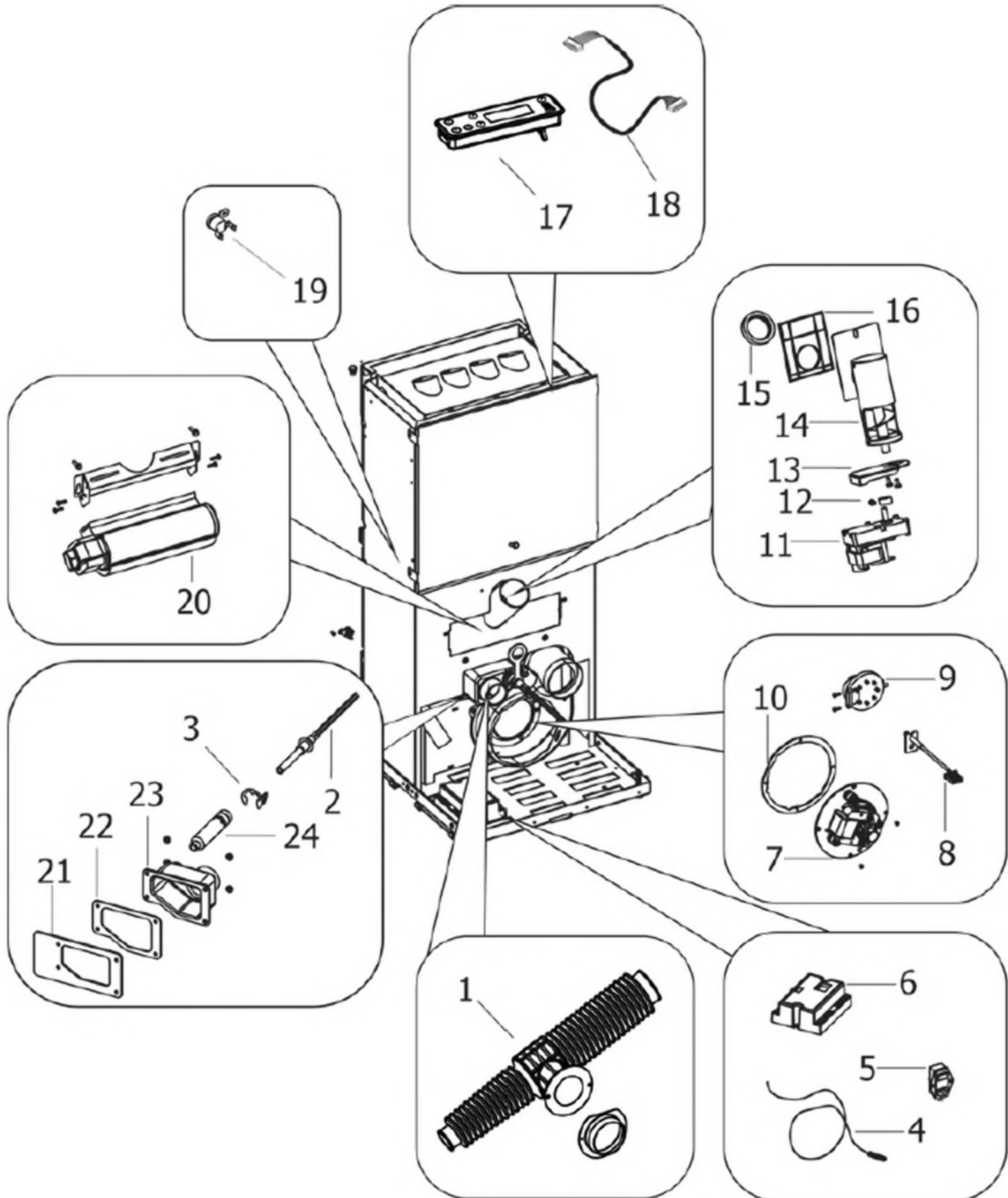

AURON

Componenti interni meccanici ed elettronici / Electronic and mechanic internal parts / Interne mechanische und elektronische Bauteile / Composants internes mécaniques et électroniques / Componentes internos electrónicos y mecánicos

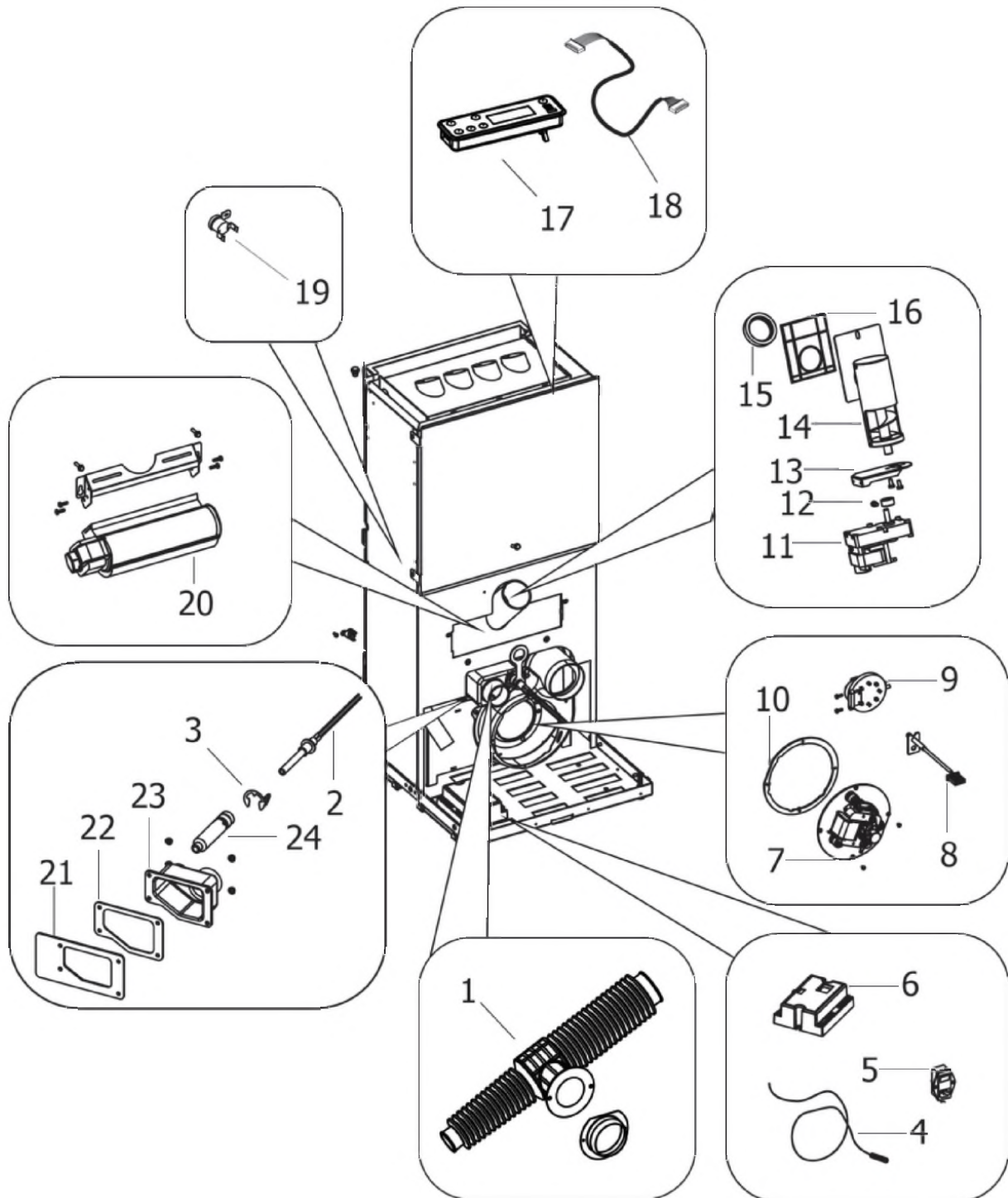

N°	Codice/Code	Descrizioni / Description / Beschreibung / Description / Description	Prezzo (€)
1	41801605200	Tubo siliconico con flangia diffusore aria / Silicone pipe with flange diffuser air / Silikonrohr mit Flansch diffuser Luft / Tuyau en silicone avec bride air diffusant / Tubo silicónico con arandela difusor aire	40.00
2	41451308101	Candeletta 315 Watt / Sparkplug 315 Watt / Zündkerze 315 Watt / Bougie 315 Watt / Bujía 315 Watt	77.00
3	41201601500	Anello arresto candeletta / Sparkplug stop / Zündkerzestopper / Butée bougie / Tope bujía	24.00
4	41451405600	Sonda ambiente / Room temperature sensor / Raumtemperaturfühler / Sonde température ambiance / Sonda	19.00

		temperatura ambiente	
5	4160193	Pulsante accensione / On/Off button / Zündungstaste / Touche d'allumage / Botón encendido	28.00
6	41451308300H	Scheda madre N100 con software precaricato / Motherboard N100 with loaded software / Hauptplatine N100 mit eingegebenem Software / Carte mère N100 avec software préchargé / Tarjeta madre N100 con software precargado	101.00
6	41451308300A	Scheda madre N100 vergine, senza software / Motherboard N100 with no software / Hauptplatine N100 ohne Software / Carte mère N100 vierge, sans software / Tarjeta madre N100 virgen, sin software	101.00
7	41451503200	Ventilatore fumi stagno / Air-tight smoke exhausted fan / Luftdichtes Rauchgasgebläse / Ventilateur fumées étanche / Ventilador humos hermético	82.00
7	41451703000	Encoder per ventilatore fumi marchio EBM / Encoder for EMB smoke fan / Encoder für EBM Rauchgasgebläse / Encoder pour ventilateur des fumées marque EBM / Encoder para ventilador humos marca EBM	22.00
7	41451209300	Encoder per ventilatore fumi marchi LN2/SIT / Encoder for LN2/SIT smoke fan / Encoder für LN2/SIT Rauchgasgebläse / Encoder pour ventilateur des fumées marques LN2/SIT / Encoder para ventilador humos marcas LN2/SIT	21.00
8	41451401300	Sonda fumi con flangia / Smoke sensor with flange / Rauchsonde mit Flansche / Sonde fumées avec bride / Sonda humos con brida	30.00
9	41451003700	Pressostato / Pressure switch / Druckschalter / Pressostat / Presostato	40.00
10	41801600800	Guarnizione ventilatore fumi / Smoke exhaust fan gasket / Dichtung Rauchabsauggebläse / Joint Ventilateur aspiration fumées / Junta ventilador aspiración humos	22.00
11	41401611831	Staffa bloccaggio motore / Motor fixing bracket / Motor Haltebügel / Etrier de blocage du moteur / Abrazadera por motor	21.00
11	41451602400	Motoriduttore 2rpm Merkle Korff senza encoder / Reduction motor 2 rpm Merkle Korff without encoder / Getriebemotor 2 rpm Merkle Korff ohne Encoder / Motorréducteur 2 rpm Merkle Korff sans codeur / Motorreductor 2 rpm Merkle Korff sin encoder	96.00
12	4120398	Connettore motoriduttore-coclea / Reduction motor-feed screw connector / Verbindung Getriebemotor-Schnecke / Connecteur motorréducteur-vis sans fin / Conector motorreductor-cóclea	22.00
13	41401611730	Base coclea / Feed screw base / Untergestell der Förderschnecke / Base de la vis sans fin / Base de la cóclea	25.00
14	41411800151	Gruppo alimentazione completo / Complete feed screw / Komplette Förderschnecke / Vis sans fin complète / Coclea de carga completa	113.00
15	41801702600	Disaccoppiatore mesc. Marrone / Brown disengaging device / Braun Verängungsrohr / Tuyau de découplage maron / Tubo de desvio marron	18.00
16	41801600400	Guarnizione gruppo caricamento / Gasket / Dichtung / Joint / Junta	20.00
17	41451702900	Pannello comandi / Control panel / Bedienblende / Panneau de commande / Panel de mandos	100.00
18	41451201900	Cavo Flat L 1,4 M / Flat cable L 1,4 M / Flat Kable L 1,4 M / Câble Flat L 1,4 M / Cable Flat L 1,4 M	21.00
18	41451601400	Cablaggio / Wiring / Verkabelung / Câblage / Cableado	34.00
19	412007004	Clickson 110°C / Clickson 110°C / Clickson 110°C / Clickson 110°C / Clickson 110°C	20.00
20	41451600800	Ventilatore aria / Air fan / Luftgebläse / Ventilateur air / Ventilador aire	76.00
21	41801601500	Guarnizione tasca braciere / Combustion pot container gasket / Brenntopfkasten Dichtung / Joint récipient brasero / Junta contenidor brasero	18.00
22	41801602300	Guarnizione codolo / Gasket / Dichtung / Joint / Junta	19.00
23	41311600100	Codolo / Tool chuck / Einspannschaft / Outil d'emmanchement / Mango	29.00
24	41601601000	Condotto candeletta / Sparkplug Conduit / Zündkerzenkanal / Conduit Bougie / Conducto Bujía	27.00
24	41501701599	Manicotto potenziamento accensione / Combustion air extension pipe / Zusatzrohr für Nachrüstung / Tuyau amélioration allumage / Tubo impulso de encendido	26.00

AURON

Componenti Struttura Esterna / External structure components / Bauteile Aussenkorpus / Composants structure externe / Componentes estructura externa

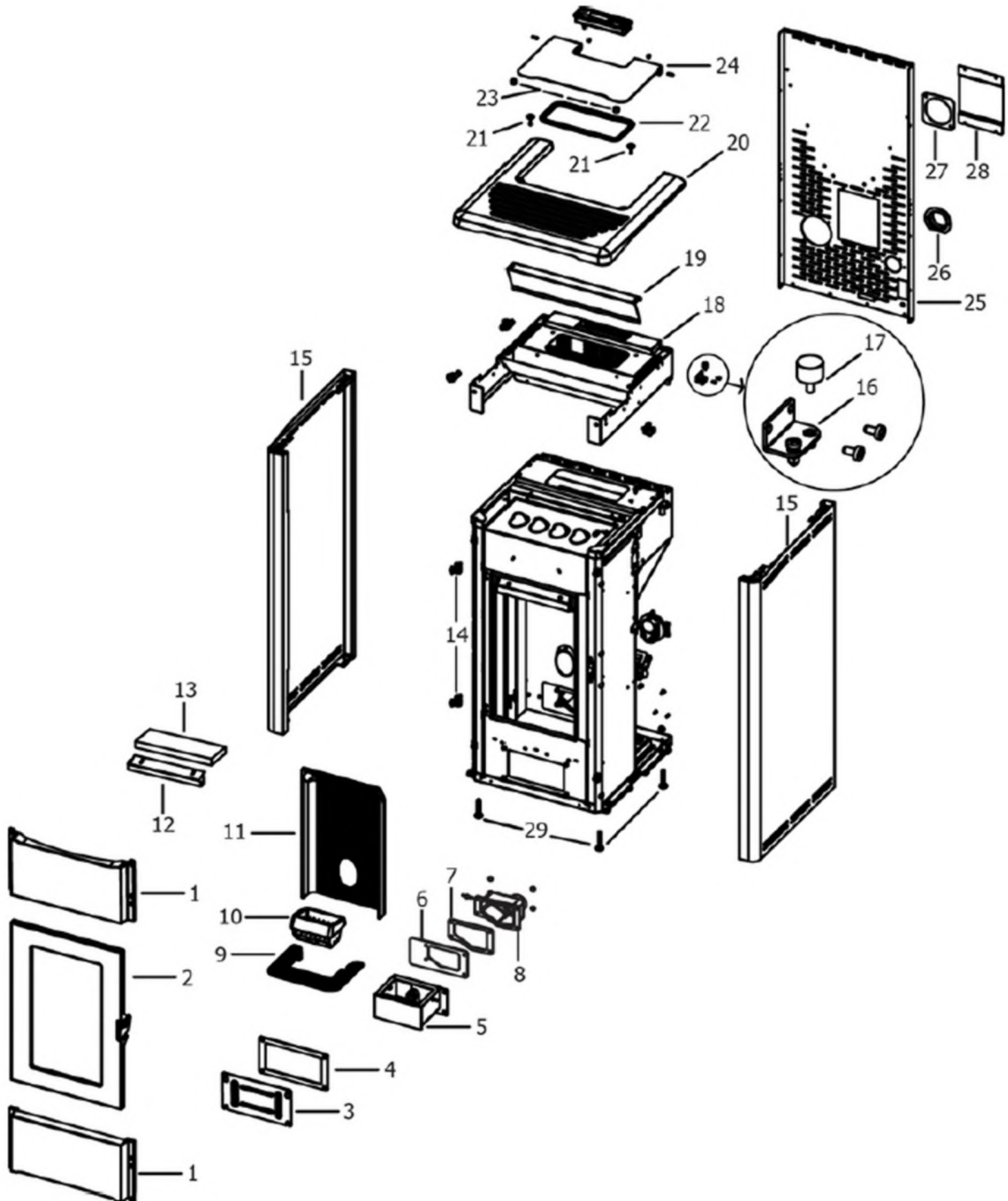

AURON

Componenti Struttura Esterna / External structure components / Bauteile Aussenkorpus / Composants structure externe / Componentes estructura externa

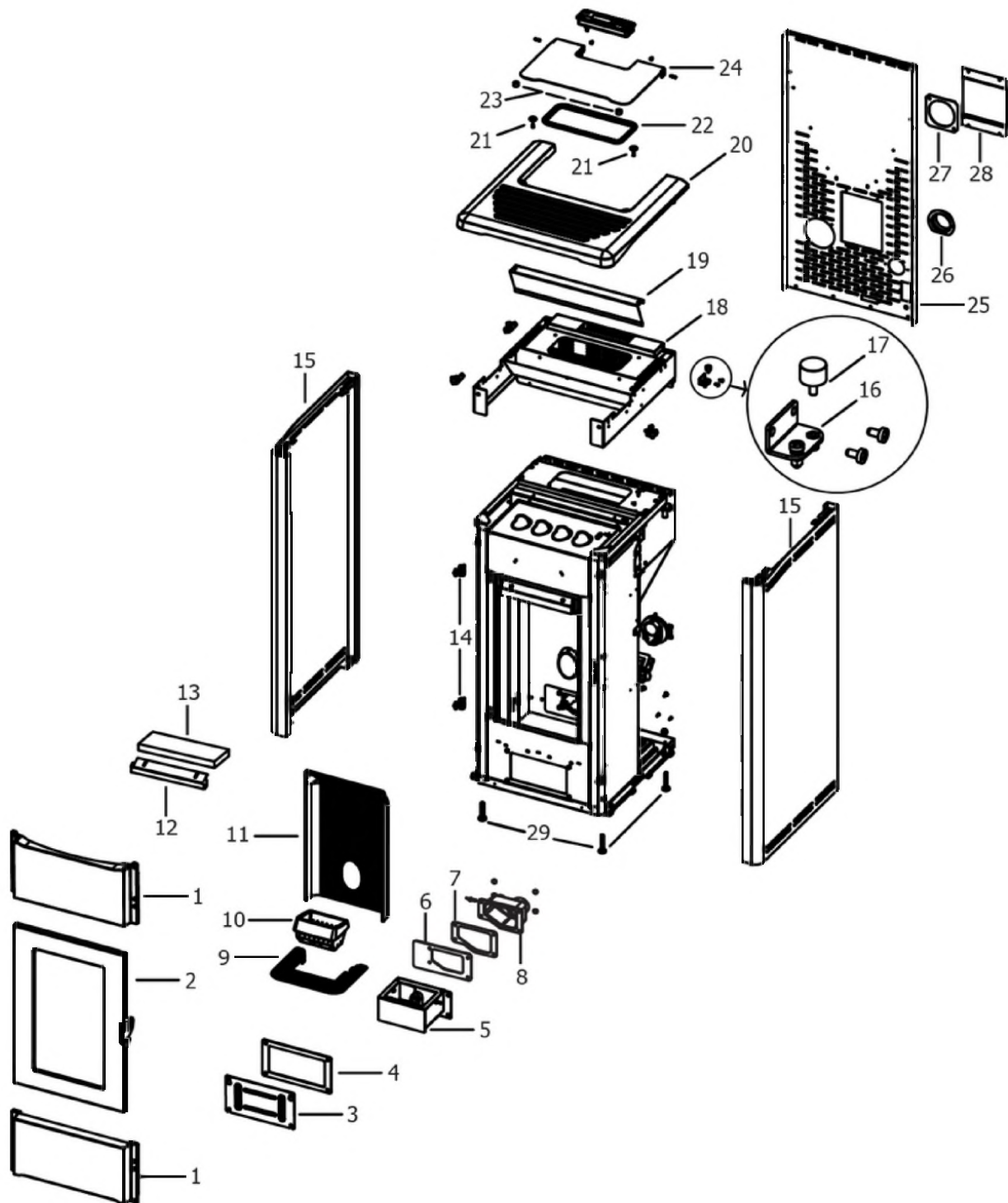

N°	Codice/Code	Descrizioni / Description / Beschreibung / Description / Descripción	Prezzo (€)
1	41301701900V	Frontale in ghisa / Cast iron front / Gusseiserne Blende Vorne / Panneau en fonte / Frontal en arrabio	114.00
2	437016063	Porta fuoco completa / Complete fire door / Komplette Feuertür / Porte complète chambre combustion / Puerta fuego completa	223.00
1	41301701900V	Frontale in ghisa / Cast iron front / Gusseiserne Blende Vorne / Panneau en fonte / Frontal en arrabio	114.00
3	41401339610	Tappo ispezione vano fumi / Smoke compartment inspection plug / Inspektionsdeckel Rauchabzug / Clapet inspection compartiment fumées / Tapón inspección compartimento humos	21.00

4	41800900600	Guarnizione / Gasket / Dichtung / Joint / Junta	21.00
4	41801599750	Kit 50 guarnizioni / Kit 50 gaskets / Bausatz 50 Dichtungen / Kit 50 joints / Kit 50 juntas	840.00
5	41402071340	Tasca braciere / Combustion pot container / Brenntopfkasten / Récipient brasero / Contenedor brasero	87.00
6	41801601500	Guarnizione tasca braciere / Combustion pot container gasket / Brenntopfkasten Dichtung / Joint récipient brasero / Junta contenedor brasero	18.00
7	41801602300	Guarnizione codolo / Gasket / Dichtung / Joint / Junta	19.00
8	41311803500	Codolo / Tool chuck / Einspannschaft / Outil d'emmanchement / Mango	44.00
9	41411634830V	Griglia focolare / Fire Box Grille / Feuerstellenrost / Grille Foyer / Rejilla Hogar	29.00
10	41301502400V	Braciere ghisa / Cast iron grate / Brenntopf aus Gusseisen / Brasero en fonte / Brasero en arrabio	51.00
11	41301502600BN	Schiena ghisa bianco / Cast iron back white / Rückwand aus Gusseisen weiß / Dosseret en fonte blanc / Parte trasera de arrabio blanco	83.00
12	41411615430V	Deflettore aria / Air deflector / Luftleitblech / Déflecteur aire / Deflector aire	26.00
13	41151600200	Deflettore focolare in vermiculite / Vermiculite deflector / Leitblech aus Vermiculite / Déflecteur en vermiculite / Deflector en vermiculite	22.00
14	41201504460	Cerniera porta (2 pz.) / Door hinge (2 pc.) / Tür Scharnier (2 Stk.) / Charnière porte (2 pc.) / Bisagra puerta (2)	24.00
15	69A17011	Rivestimento Antracite / Anthracite coating / Bekleidung Anthrazit / Revêtement Anthracite / Revestimiento Antracita	0.00
15	69A17012	Rivestimento alluminio / Aluminium cladding / Verkleidung Aluminium / Revêtement aluminium / Revestimiento aluminium	0.00
15	69A17013	Rivestimento bianco / White cladding / Verkleidung Weiss / Revêtement blanc / Revestimiento blanco	0.00
15	69A17014	Rivestimento tortora / Taupe cladding / Verkleidung Taupe / Revêtement taupe / Revestimiento color topo	0.00
15	69A17015	Rivestimento rosso / Red cladding / Verkleidung Rot / Revêtement rouge / Revestimiento rojo	0.00
15	69A17011	Rivestimento Antracite / Anthracite coating / Bekleidung Anthrazit / Revêtement Anthracite / Revestimiento Antracita	0.00
15	69A17012	Rivestimento alluminio / Aluminium cladding / Verkleidung Aluminium / Revêtement aluminium / Revestimiento aluminium	0.00
15	69A17013	Rivestimento bianco / White cladding / Verkleidung Weiss / Revêtement blanc / Revestimiento blanco	0.00
15	69A17014	Rivestimento tortora / Taupe cladding / Verkleidung Taupe / Revêtement taupe / Revestimiento color topo	0.00
15	69A17015	Rivestimento rosso / Red cladding / Verkleidung Rot / Revêtement rouge / Revestimiento rojo	0.00
16	41411770430	Supporto / Bracket / Gestell / Support / Soporte	19.00
17	41201704500	Supporti antivibranti (10pz) / Anti-vibration supports (10pcs) / Schwingungsdämpfend Halterungen (10 Stck.) / Suport pour éléments antivibrations (10 pcs) / Apoyo anti-vibraciones (10 pzs)	41.00
18	41411999650	Distanziale serbatoio / Hopper spacer / Pellettank Abstandsstück / Espaceur réservoir / Separador depósito pellet	193.00
19	41411696730P	Riparo calore serbatoio / Hopper heat protection / Beähler- Wärmeschutz / Protection chaleur reservoir / Resguardo calor deposito pellet	31.00
20	41301701800V	Top in ghisa / Cast iron top / Abdeckplatte aus Gusseisen / Dessus en fonte / Top en arrabio	194.00
21	41801002300	Paracolpi in silicone Ø 8/5 (2pz) / Silicone bumpers Ø 8/5 (2pcs) / Schlagschutzgummi Ø 8/5 (2 Stck) / Pièces silicone antichoc Ø 8/5 (2pcs) / Anti-golpes en silicona Ø 8/5 (2pzs)	18.00
21	41801002300	Paracolpi in silicone Ø 8/5 (2pz) / Silicone bumpers Ø 8/5 (2pcs) / Schlagschutzgummi Ø 8/5 (2 Stck) / Pièces silicone antichoc Ø 8/5 (2pcs) / Anti-golpes en silicona Ø 8/5 (2pzs)	18.00
22	41801601400	Guarnizione coperchio serbatoio / Pellet hopper cover gasket / Deckel Pelletbehälter Dichtung / Joint couvercle réservoir pellet / Junta tapa depósito pellet	21.00
23	41801657900	Magneti (pz.2) / Magnet (pcs.2) / Magnet (stk. 2) / Aimant (pcs.2) / Imán (pz.2)	22.00
24	41411770840	Coperchio serbatoio / Hopper cover / Deckel Pelletbehälter / Couvercle réservoir / Tapa depósito	76.00
25	41401852231	Schiena serbatoio / Hopper rear back / Rückwand von Pelletbehälter / Dos du réservoir / espalda de depósito	47.00
26	41600900460	Flangia Ø 60 / Flange Ø 60 / Flansch Ø 60 / Bride Ø 60 / Brida Ø 60	21.00
27	41400904810	Flangia tubo ingresso aria / Flange for combustion air aspiration tube / Flansch Verbrennungsluft Förderrohr / Bride tuyau aspiration air comburant / Brida tubo aspiración aire de combustión	20.00
28	41401612530	Coperchio motoriduttore / Reduction motor cover / Deckel des Getriebemotors / Couvercle motoréducteur / Tapa del motorreductor	34.00
29	41200906660	Piedini di appoggio (4 pz.) / Support feet (4 pcs.) / Einstellfüße (4 Stck.) / Vérins d'appui (4 p.es) / Pies de apoyo (4 piezas)	19.00

AURON

Porta fuoco / Fire door / Feuertür / Porte foyer / Puerta hogar

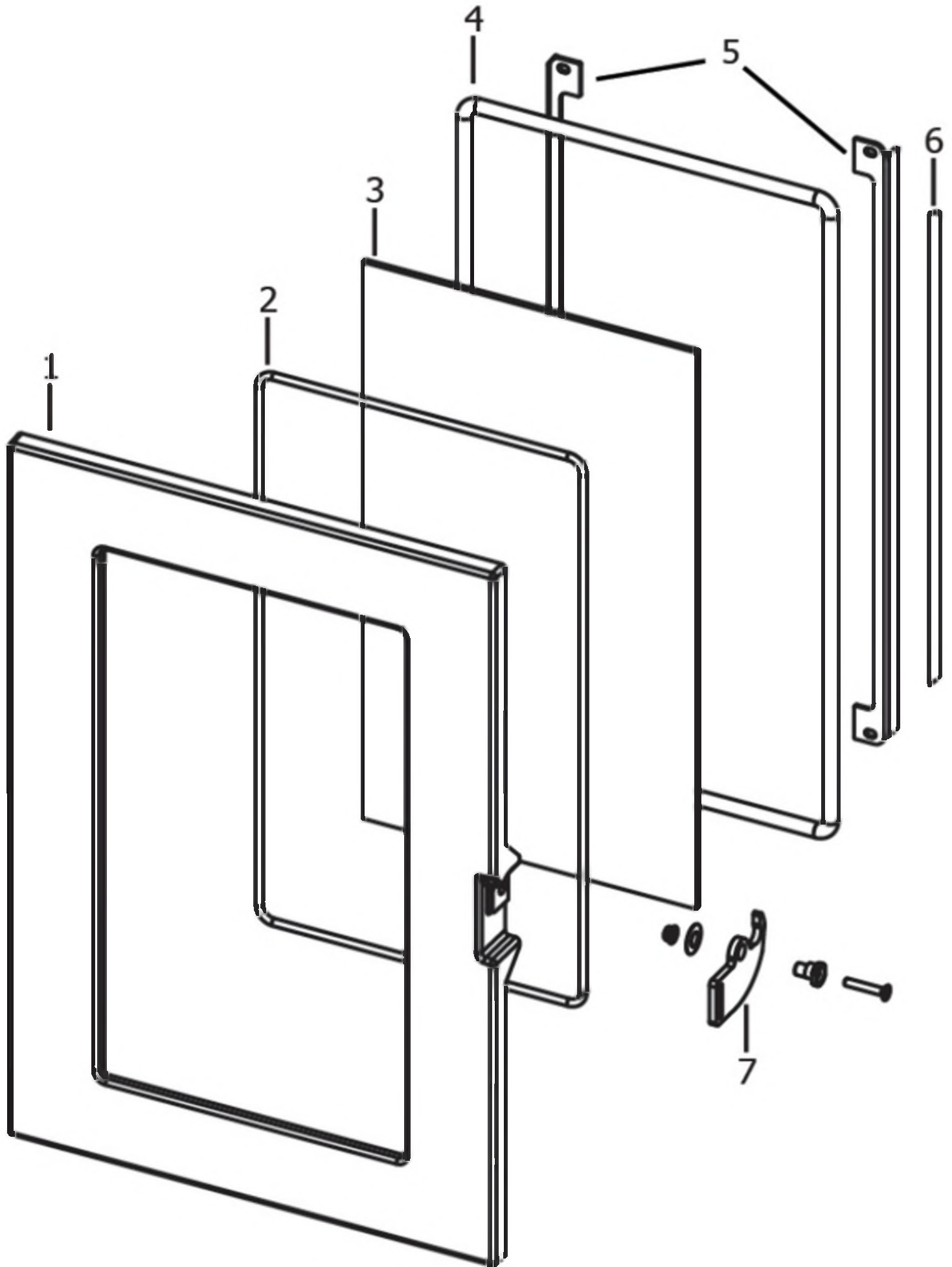

AURON

Porta fuoco / Fire door / Feuertür / Porte foyer / Puerta hogar

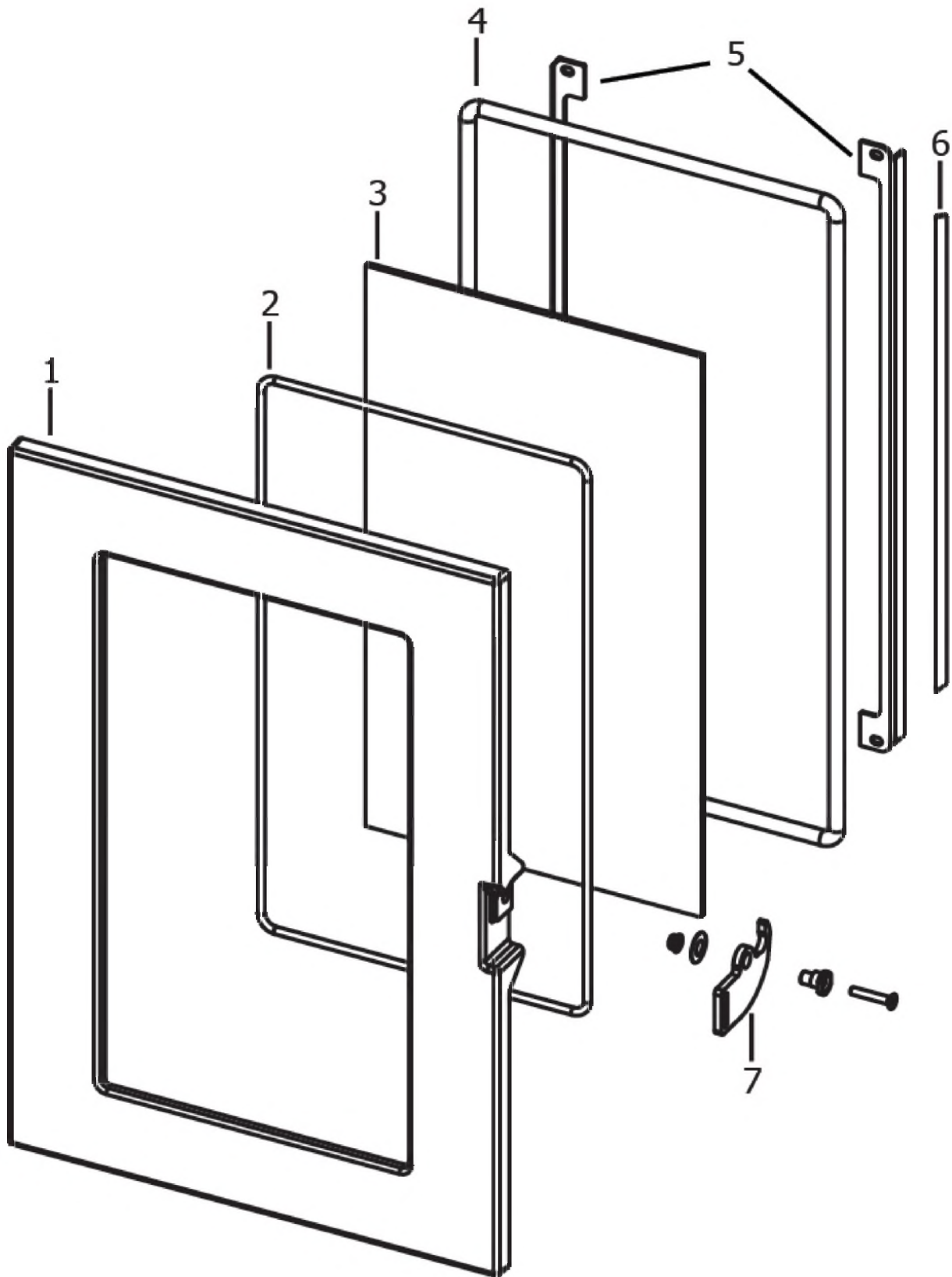

N°	Codice/Code	Descrizioni / Description / Beschreibung / Description / Descripción	Prezzo (€)
1	41301502300V	Telaio porta fuoco / Fire door frame / Rahmen Feuertür / Cadre porte foyer / Armazón puerta hogar	124.00

2	41801603300A	Guarnizione Ø5 5mt / Gasket Ø5 5mt / Dichtung Ø5 5mt / Joint Ø5 5mt / Junta Ø5 5mt	42.00
2	41801603300B	Guarnizione Ø5 50mt / Gasket Ø5 50mt / Dichtung Ø5 50mt / Joint Ø5 50mt / Junta Ø5 50mt	299.00
2	41801603300C	Guarnizione Ø5 5mt + silicone / Gasket Ø5 5mt + silic / Dichtung Ø5 5mt + Silikon / Joint Ø5 5mt + silic / Junta Ø5 5mt	63.00
3	41701600300	Vetroceramico porta ghisa / Cast iron door glass / Glaskeramikscheibe Tür aus Gusseise / Vitrocéremique porte en fonte / Cristal cerámico puerta en arrabio	79.00
4	4120104A	Cordino fibrocaramico Ø 12 mm (5 mt.) / Ceramic fibre cord Ø 12 mm (5 m.) / Keramikfaserschnur Ø 12 mm (5 m) / Cordon en fibre céramique Ø 12 mm (5 m) / Junta a cuerda de fibra cerámica Ø 12 mm (5 m)	36.00
4	4120104B	Cordino fibrocaramico Ø 12 mm (50 mt.) / Ceramic fibre cord Ø 12 mm (50 m.) / Keramikfaserschnur Ø 12 mm (50 m) / Cordon en fibre céramique Ø 12 mm (50 m) / Junta a cuerda de fibra cerámica Ø 10 mm (52 m)	210.00
4	41201041	Kit sostituzione cordino (cordino+silicone) Ø 12 mm / Cord replacement kit (cord + silicon) Ø 12 mm / Schnuraustauschsatz (Schnur+Silikon) Ø 12 mm / Kit remplacement cordon (cordon + silicone) Ø 12 mm / Kit sustitución junta a cuerda (junta a cuerda+silicón) Ø 12 mm	50.00
5	41411622030V	Profilo fermavetro / Fastening bracket profile / Haltebügel für Scheibebefestigung Profil / Profil patte de fixation / Perfil fermacristal	37.00
6	4120573A	Guarnizione a nastro 8 mm (5 mt.) per porta / Door strip gasket 8 mm (5 m) / Türbanddichtung 8 mm (5 m) / Joint ruban 8 mm (5 m) pour porte / Guarnición de cinta para puerta 8 mm (5 m)	32.00
6	4120573B	Guarnizione a nastro 8 mm (50 mt.) per porta / Door strip gasket 8 mm (50 m) / Türbanddichtung 8 mm (50 m) / Joint ruban 8 mm (50 m) pour porte / Guarnición de cinta para puerta 8 mm (50 m)	162.00
7	41401424160	Maniglia completa / Complete handle / Kompletter Griff / Poignée complète / Tirador completo	25.00