

EC 85

L-D107.04-BM

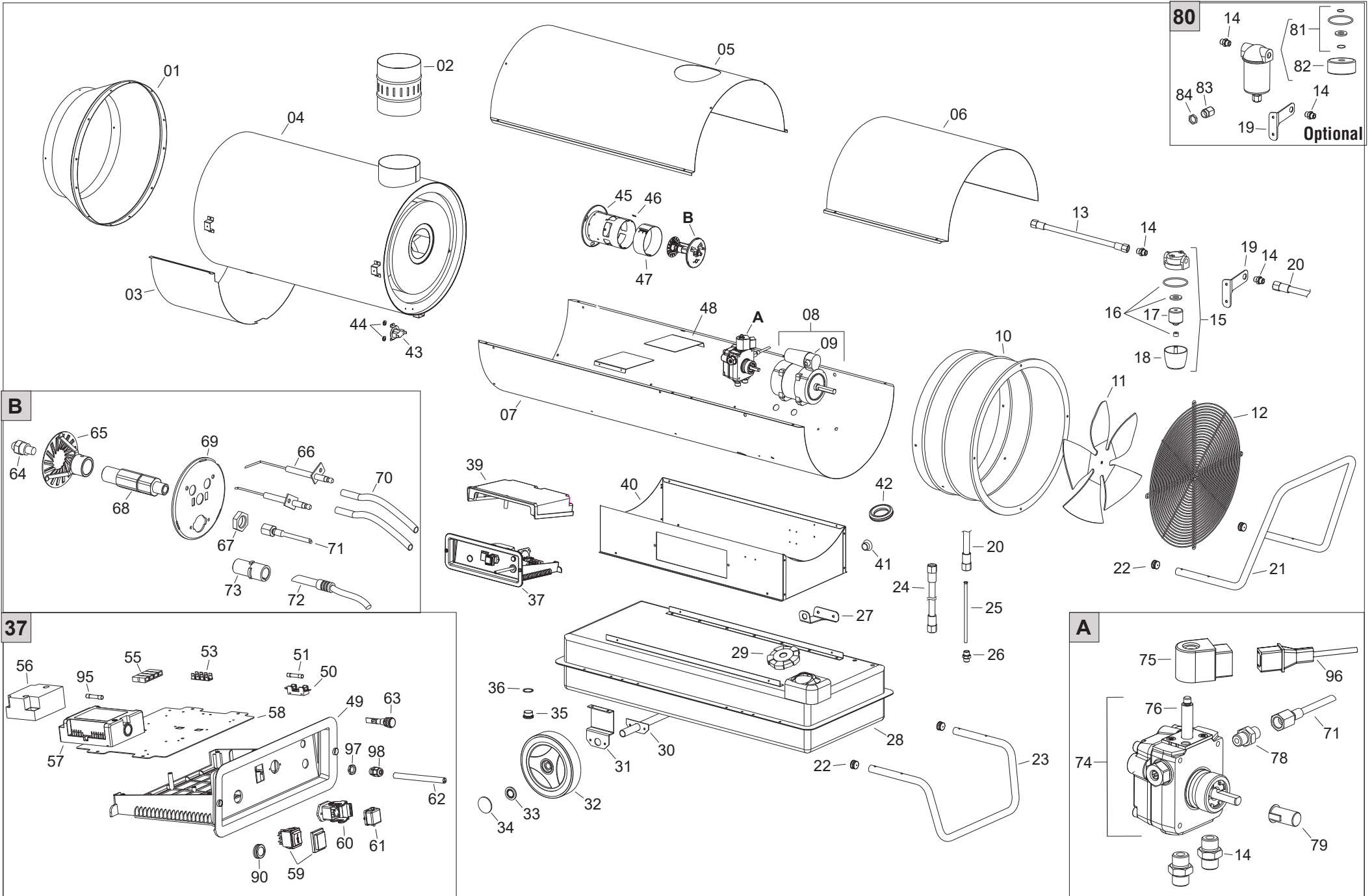

PL 01/18			Da N.° serie	De No. Serie	Von Masch. Nr.	From S/N
20921001						
POS	P/N	LEGENDA	DESCRIZIONE	DESCRIPTION	BESCHREIBUNG	DESCRIPTION
01	G06114-3001	-	Cono diffusore	Embout conique	Ausblaskonus	Outlet cone
02	G06492	Ø 150	Raccordo camino	Raccord cheminée	Schornsteinanschluss	Chimney fitting
03	G06175	-	Pannello isolante	Panneau d'isolation	Isolierplatte	Insulating panel
04	G06177-09	-	Camera di combustione	Chambre de combustion	Brennkammer	Combustion chamber
05	G06413-3001	-	Carrozzeria superiore	Carrosserie sup.	Karosserie Oberteil	Upper body
06	G06122-3001	-	Pannello ispezione	Porte visite	Inspektionsklappe	Inspection panel
07	G06179-3001	-	Carrozzeria inferiore	Carrosserie Inf.	Karosserie Unterteil	Lower body
08	E10694	750 W - 230V - 50Hz	Motore	Moteur	Motor	Motor
09	E11244	20 µF	Condensatore	Condensateur	Kondensator	Capacitor
10	G06126-3001	-	Convogliatore aria	Air collecteur	Luftkollektor	Air conveyor
11	T10259	Ø 500 - 33°	Ventola	Ventilateur	Lüfter	Fan
12	P30129	-	Griglia aspirazione	Grille aspiration	Ansauggitter	Inlet grill
13	I40330	L = 420mm - 1/4" FF	Tubo gasolio flessibile	Flexible fuel	Flexibler Heizölschlauch	Flex diesel pipe
14	I20104	1/4"M - 1/4"M	Raccordo ferro	Raccord fer	Anschluss, Eisen	Iron fitting
15	T20201	1/4"FF	Filtro gasolio	Filtre fuel	Heizölfilter	Diesel filter
16	T20234	GIULIANI ANELLO	Kit guarnizioni filtro	KIT OR filtre	Satz Filterdichtungen	Filter seal kit
17	T20206	-	Cartuccia filtro	Cartouche filtre	Filtereinsatz	Filter cartridge
18	T20212	-	Contentitore filtro	Conteneur filtre	Filtergehäuse	Filter container
19	G06104-9005	-	Staffa supporto filtro	Étrier support filtre	Trägerbügel Filter	Filter support bracket
20	I40329	L = 260mm - 1/4" FF	Tubo gasolio flessibile	Flexible fuel	Flexibler Heizölschlauch	Flex diesel pipe
21	P20176-9005	-	Maniglia	Poignée	Griff	Handle
22	C30355	Ø25	Tappo copritubo	Bouchon tuyau	Schlauchstöpsel	Pipe cap
23	P20177-9005	-	Piede	Support	Stütze	Support
24	I40331	L = 580mm - 1/4" FF	Tubo gasolio flessibile	Flexible fuel	Flexibler Heizölschlauch	Flex diesel pipe
25	I30696	L = 220mm	Pescante	Tuyau d'aspiration	Ansaugrohr	Suction pipe
26	I30737	1/4" M - M12x1,75 M	Raccordo ottone	Raccord laiton	Messingfitting	Brass fitting
27	G06068-9005	-	Supporto cavo elettrico	Crochet câble d'alimentation	Halterung Stromkabel	Power cord support
28	G06128-9005	105 l	Serbatoio gasolio	Réservoir fuel	Heizölbehälter	Fuel tank
29	C30356	Ø 76	Tappo serbatoio	Bouchon réservoir	Behälterstopfen	Tank cap
30	G06138-9005	Ø 20	Assale	Essieu	Achse	Wheel axle
31	G06106-9005	-	Staffa supporto assale	Étrier support essieu	Trägerbügel Achse	Wheels axle support bracket
32	C10544	Ø 250 - Ø 20,5	Ruota	Roue	Rad	Wheel
33	M20203	Ø 20	Rondella elastica	Clips de fixation	Sprengring	Elastic washer
34	C10513-N	Ø 200 - 250	Copri ruota nero	Couvre roue noire	Radabdeckung schwarz	Black wheel cover
35	I25020	M16x1,5	Tappo scarico serbatoio	Bouchon de vidange réservoir	Behälterablassstopfen	Drain cap
36	M20313	Ø3/8"	Rondella	Rondelle	Unterlegscheibe	Washer
37	G00308	-	Quadro elettrico	Coffret électrique	Schaltkasten	El. control box
39	P50127	-	Copertura quadro elettrico	Couverture coffret électrique	Abdeckung Schalttafel	Control box cover
40	G06180-3001	-	Basamento	Base	Sockel	Base
41	C30319	Ø25	Tappo copriforo	Bouche trou	Lochstöpsel	Hole cap
42	C30372	Ø 25,4mm - Ø34,9 mm	Passacavo	Protection cable	Kabeldurchgang	Cable protection
43	E50102	-	Termostato di sicurezza	Thermostat de sécurité	Sicherheitsthermostat	Safety thermostat
44	M20107	Ø5 x Ø15 x 1,5	Rondella	Rondelle	Unterlegscheibe	Washer
45	G06266	-	Boccaglio	Gueulard	Brennerrohr	Blast tube

PL 01/18			Da N.° serie	De No. Serie	Von Masch. Nr.	From S/N
20921001						
POS	P/N	LEGENDA	DESCRIZIONE	DESCRIPTION	BESCHREIBUNG	DESCRIPTION
46	E20671	6,3x0,8 mm	Morsettiera	Barrette de connection	Klemmenleiste	Terminal board
47	G06183	-	Serranda regolazione aria	Tablier réglage air	Luftregelklappe	Air adjustment shutter
48	G06394	-	Convogliatore aria	Air collecteur	Luftkollector	Air conveyer
49	G06153	-	Pannello quadro elettrico	Panneau du coffret électrique	Schaltkastenplatte	El. control box panel
50	E20508	6 x 32	Portafusibile	Porte fusible	Sicherungshalter	Fuse holder
51	E10308	6x30 - 10A - T	Fusibile	Fusible	Sicherung	Fuse
53	E20319	-	Morsettiera per cavi terra	Barrette de connection	Klemmenleiste für Erdungskabel	Ground terminal board
55	E20305	12 pin	Morsettiera	Barrette de connection	Klemmenleiste	Terminal board
56	E10920	TRK1	Trasformatore alta tensione	Transformateur H.T.	Hochspannungstrafo	H.T. Transformer
57	E40152	REDGUN02 - 230V	Apparecchiatura controllo fiamma	Disp. Contrôle flamme	Flammenüberwachung	Flame control box
58	G06073	-	Piastra supporto	Plaque support	Montageplatte	Support plate
59	E10102-P	I - 0 - II	Interruttore bipolare	Interrupteur	zweipoliger Schalter	Switch
60	E20640	3P+T	Connettore presa termostato	Fiche thermostat	Steckdose	Thermostat plug
61	E20665	-	Coperchio presa termostato	Couvercle prise thermostat	Deckel Thermostatbuchse	Thermostat plug cover
62	E30446-1	L = 1,5m - SCHUKO	Cavo alimentazione elettrica	Câble d'alimentation	Stromversorgungskabel	Power cord
63	E11030	230V	Lampada	Lampe	Lampe	Lamp
64	T20356	DELAVAN 1,50 GPH 80° W	Ugello gasolio	Gicleur	Düse	Nozzle
65	G01077	-	Anello diffusore	Diffusaire annulaire	Stauscheibe	Diffuser ring
66	E10215	-	Elettrodo accensione	Électrode allumage	Zündelektrode	Ignition electrode
67	I31034	M14	Controdado ottone	Contre-écrou laiton	Kontermutter, Messing	Brass lock nut
68	I33005	-	Raccordo portaugello	Support gicleur	Düsenhalter	Nozzle support
69	G06228	-	Disco supporto bruciatore	Bride brûleur	Trägerscheibe Brenner	Burner support disc
70	G02075	L = 1000 mm	Cavo alta tensione	Conn. câble	Hochspannungskabel	H.T. Cable connect.
71	I40192	L = 250mm 1/8"F - 1/8"F	Microtubo	Microtube	Feinschlauch	Micropipe
72	E50331	GIORDANO FI02 L = 1m - Black	Fototransistor	Phototransistore	Fototransistor	Phototransistor
73	E50327-20	D 6	Supporto fotoresistenza	Support photorésistance	Halterung Photowiderstand	Photoresistor support
74	T20451	DANFOSS BFP21	Pompa gasolio	Pompe fuel	Heizölpumpe	Diesel pump
75	T20114	DANFOSS BFP11-21 - 230V	Bobina elettrovalvola	Bobine E.V.	Spule Magnetventil	Solenoid coil
76	T20117	DANFOSS BFP11-21	Corpo elettrovalvola	Corps électrovalve	Magnetventilgehäuse	Solenoid valve body
78	I20115	1/8"M - 1/8"M	Raccordo ferro	Raccord fer	Anschluss, Eisen	Iron fitting
79	E10698	SIMEL	Giunto motore - pompa	Accouplement moteur-pompe	Motor/Pumpe-Kupplung	Motor-pump coupling
80	02AC548	1/4"FF - 100 W	Kit filtro gasolio con preriscaldamento	Kit Filtre pre-chauffage	Satz Heizölfilter mit Vorwärmung	Diesel pre-heaters filter kit
81	T20241	FAG	Kit guarnizioni filtro	KIT OR filtre	Satz Filterdichtungen	Filter seal kit
82	T20242	-	Cartuccia filtro	Cartouche filtre	Filtereinsatz	Filter cartridge
83	E20953	PG11	Pressacavo	Presse étoupe	Kabeldurchgang	Cable fastener
84	E20954	PG11	Dado per pressacavo	Ecrou pour presse étoupe	Mutter für Kabeldurchgang	Cable fastener nut
90	E20418	-	Protezione pulsante blocco	Protection bouton d'arrêt	Schutz Sperrschalter	Stop button protection
95	E10303	5x20 - 10A - T	Fusibile	Fusible	Sicherung	Fuse
96	T20442	L = 1000 mm	Cavo elettrovalvola	Câble électrovalve	Kabel Magnetventil	Solenoid valve cable
97	E20965	PG 13,5	Dado per pressacavo	Ecrou pour presse étoupe	Mutter für Kabeldurchgang	Cable fastener nut
98	E20964	PG 13,5	Pressacavo	Presse étoupe	Kabeldurchgang	Cable fastener