

BMV 3-4-5 (2018->)

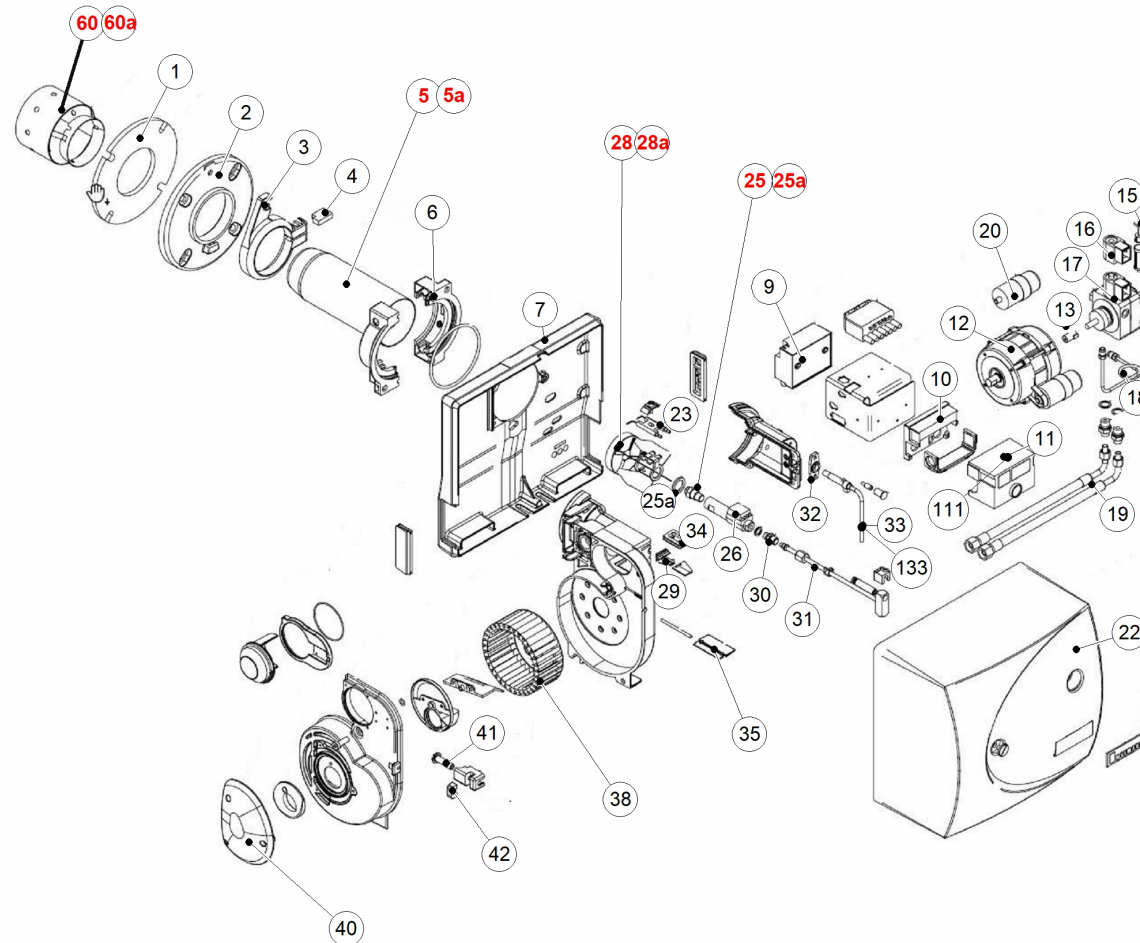













Burner control and flame sensor	
Old (before 2019)	New (2019)
LOA24 (53429131)	LMO14 (54768021)
QRB1 (blue) – A1005944 (old 537D8025) without holder	QRB4 (red) + Holder (A1007560)
QRB4 (red) <b>not compatible</b> with LOA	QRB1 <b>compatible</b> Older version compatible (with specific holder)



## BMV 3-4-5 (2018-&gt;)



Code	Code GA	Quant.	Photo	Description	De --- A ---	Remarque
1	55429159	785279	1	Joint bride ronde BMV & BMR22-32-52		
2	537D8147	786403	1	Plaque de collerette BMV		
3	A1002667	787015	1	Clame fix.brûleur BMV 2012->		
4	537D8144	786401	1	Joint d'étanchéité collerette BMV		
5	A1005205	590057	1	Tube comb.d:80/60 L:203,5 BMV3-4 "E"	01-04-18-	BMV 3-4
5a	A1005206		1	Tube combustion d:80/62 L:202,5 BMV5 "F"	01-04-18-	BMV 5
6	537D8150	786405	1	Flasque bipartie BMV		
7	A1002710	787021	1	Plaque de base BMV1-2 2012-> (-98)		
8	537D5013	786175	1	Câble transfo allumage		
9	53429151	785075	1	Transfo allumage EBI 052F0030		
10	537D8035	786376	1	Socle enfichable BMV		
11	53429131	785064	1	Coffret de sécurité LOA 24 brûleur		
111	54768021	785253	1	Automate brûleur BMR31-33-BMe1	11-02-20-	LMO14.11CHA
12	537D8186	786416	1	Moteur 90W BMV (V13) avec condensateur		
13	537D8081	786381	1	Accouplement moteur-pompe BMV		
133	A1007560	780396	1	Cellule BMV1-5 (10011.00105)	11-02-20-	Only for LMO burner control
14	537D5010	786173	1	Câble électro-aimant		
15	537D8024	786367	1	Cartouche filtrante pour pompe		
16	A1005310	787441	1	Bobine électrovanne BMV T85	01-05-18-	prev: 537d8030
17	537D8033	786375	1	Pompe BMV1 (Danfoss BFP21 L3 R) +bobine		

## BMV 3-4-5 (2018-&gt;)

Code	Code GA	Quant.	Photo	Description	De --- A ---	Remarque
18	537D8032	786374	1	 Conduite de pression de fioul		
19	537D8082	786382	2	 Flexible fioul 1100 mm		
20	537D8028	786371	1	 Condensateur (moteur BMV) 3µF		
21	537D5011		1	Câble de connexion du moteur		
22	537D8093	786387	1	Capot noir brûleur BMV		
23	537DZ024	786450	1	 Bloc d'électrodes BMW		
24	537D5014	786176	2	 Câble allumage BMW		
25	A1005207	787433	1	Gicleur Danfoss 0,60 Gus 60°H	01-04-18-	BMV 3-4
25a	A1005208		1	Gicleur Danfoss 1,00 Gus 45°H	01-04-18-	BMV 5
26	53429132	785065	1	 Préchauffeur (seul) FPHB 5 (->FPHE 5)		Prev: 537D8034
27	537D5012	786174	1	 Câble et prise mâle du prechauffeur		
28	537D9000	786423	1	 Accroche flamme BMV1-3-4 (4 fentes)	01-04-18-	BMV 3-4
28a	537D9001	786424	1	 Accroche flamme BMV2-5 (12 fentes)	01-04-18-	BMV 5
30	537D8149		1	Raccord préchauffeur BMV		
31	537D1036	786083	1	 Tube porte-gicleur BMV1-2 (223,5mm)		
32	537D8145	786402	1	Cadre pour cellule BMV		
33	A1005944	910421	1	Cellule BMV1-5 (10011.00105)	11-02-20-	Prev : 537D8025
34	5476A030	786476	1	 Passe-fil câble allumage BMW		
35	537D8084	786384	1	Clapet d'air BMV		
38	537D8026	786369	1	 Roue ventil.BMV		



BMV 3-4-5 (2018->)

Code	Code GA	Quant.	Photo	Description	De --- A ---	Remarque
40	537D8184	1		Cache entrée d'air BMV		
41	A1002666	1		Axe commande réglage d'air BMV		
42	537D8116	910438	1	Clame noire réglage d'air BMV		
60	A1005185	590056	1	Tube recirculation E (100x1x70) BMV 3-4	01-04-18-	BMV 3-4
60a	A1005186		1	Tube recirculation F (100x1x100) BMV 5	01-04-18-	BMV 5
99	537D8159	786412	1	 Réduction 80/50 BMV1 FV		