

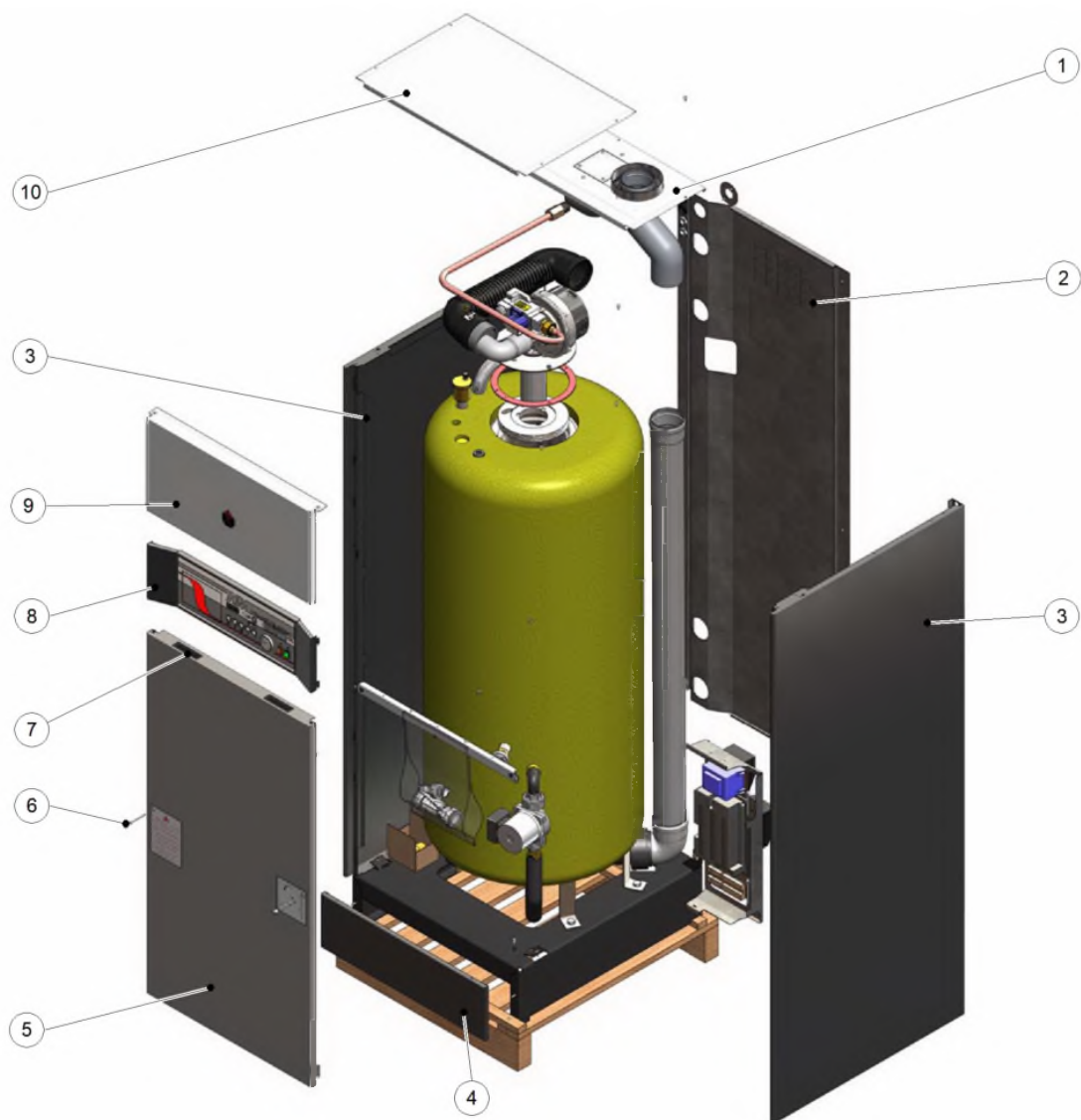



Panels HM25-35TC V13





Panels HM25-35TC V13





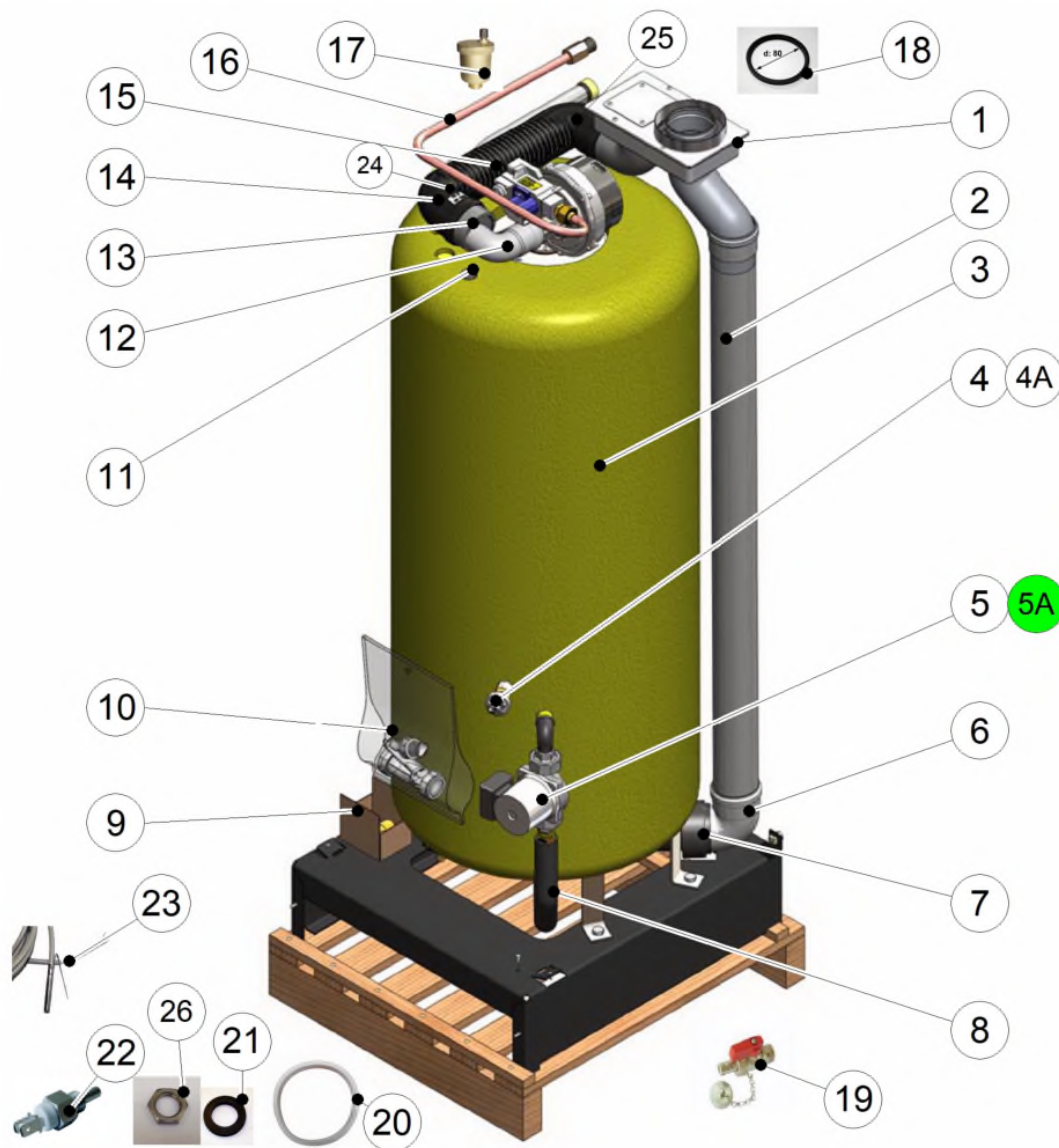









	Code	Code GA	Quant.	Photo	Description	De --- A ---
1	28475488		1		Couvercle arr.HM25-35-45TC V14	01-01-14-
2	28474488		1		Arrière cpl.HM25-35-45TC V14	01-01-14-
3	28471488		2		Lat.G&D cpl HM25-35-45TC V14	01-01-14-
5	28473485		1		Avant inf.cpl HM25-35-45TC V14	01-01-14-
6	497B1060	785883	2		Bouchon blanc Dp:9,5	01-01-14-
7	49410280	784904	2		Poignée rectangulaire panneaux (HDPE)	01-01-14-
8	21477485	784669	1		Tableau (tôle) HM25-35-45TC	01-01-14-
9	28478425		1		Avant sup.cpl HM25-35-45TC V14	01-01-14-
10	21479488	784693	1		supérieur avant HM25-35-45TC	01-01-14-
4	28476425		1		Avant socle cpl HM25-35-45TC V14	01-01-14-

Internal HM25-35TC V13











Internal HM25-35TC V13

Code	Code GA	Quant.	Photo	Description	De --- A ---	Remarque
1	507F3046	785943	1	 Adaptat.80+80->80-125 HM35-45TC	01-01-14-	
2	537D6237	786233	1		01-01-14-	
3	30540605	784811	1		01-01-14-	
4A	A1002747	787022	1	 Pressost.manque eau 1/4 CEME	01-01-16-	
4	A1003191	787140	1	 kit pressostat 220V (prev: 557a1056)	01-08-16-	
5	557A4009	786700	1	 Circul.RS25/6-3 L130-3 G6/4	01-01-14-31-07-15	non ERP
5A	257F1145	785792	1	 Circul.HEP câblé HM25->45TC V13 (ERP)	01-08-15-	ERP
6	537D6403	786285	1	 Coude 90° MF DN80 PP gris+joint	01-01-14-	
7	10800261	784432	1	 Bac condens.PPS+joint HM35TC-25 C	01-01-14-	
8	507F4272	786017	1		01-01-14-	
9	557A1079	786685	1	 Ensemble soupape secur.3bar 50 kW	01-01-14-	
10	A1003132	787101	1	 Siphon DH50+bille+bague+joint	01-10-16-	PREV 557A8004
11	39438027	784821	1	 Doigt de gant inox 1/2x500	01-01-14-	
12	537D6090	786188	1	 Coude 90° MF DN50 PVC+joint	01-01-14-	
13	537D6092	786189	1	 Réduction PVC Ø80/50 MF	01-01-14-	
14	537D6508	786355	1		01-01-14-	
15	537D6238	786234	1	 Tube flexible air D80 L320	01-01-14-	
16	507F4111	785966	1		01-01-14-	
17	557A3001	786695	1	 Purgeur air auto.1/2 laiton	01-01-14-	
18	557A0105	786600	1	 Joint à lèvres DN80 HR-EPDM noir	01-01-14-	



Internal HM25-35TC V13





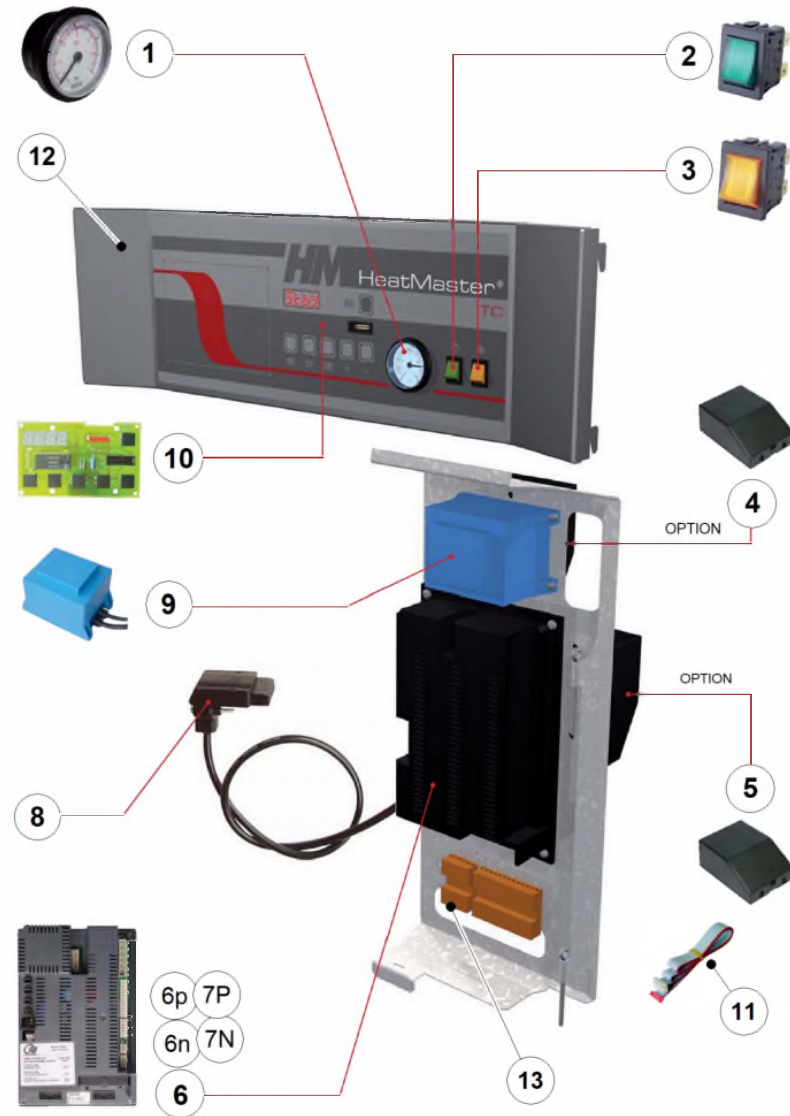











Code	Code GA	Quant.	Photo	Description	De --- A ---	Remarque
19	55426001	785274	1	 Robinet de vidange 1/2	01-01-14-	
20	557A0141	786618	1	 Joint DI:166 bac.condens.HM35TC	01-01-14-	
21	A1004464	787332	1	Joint 28-45x4 Viton bac condens.HMTC	01-01-14-	
22	5476G008	786492	1	 Sonde NTC 12K d5x18 1/8 +faston	01-01-14-	
23	547D3018	786561	1	 Sonde NTC 12K L1500 pour ballon	01-01-14-	
24	53437039	785089	1	 Prise de pression D:8,5 M5	01-01-14-	
25	537D6352	786269	1	Coude 90° D:80 PP air (noir)	01-01-14-	
26	4779A011	785844	1	 Ecrou 3/4 DIN431A inox HMTc	01-01-14-	

Control panel HM25-35TC





Control panel HM25-35TC

Code	Code GA	Quant.	Photo	Description	De --- A ---	Remarque
1	54763017	785201	1	 Manomètre 0-4 bar 60psi Ø37mm noir		
2	54766016	785234	1	 Interrupteur 2P vert		
3	54766017	785235	1	 Interrupteur 2P jaune		
4	10800094	784374	1	 Kit module d'alarme AM3-2		OPTION
5	10800095	784375	1	 Kit module 2ème circ.chauf. AM3-11		OPTION
6	5476G042	786514	1	 MCBA réglé HM35TC		HM35TC
6n	5476G064	786530	1	 MCBA réglé HM25TC V10 G20-25	-01-01-15	HM25TC V10 G20-25
6p	5476G065	786531	1	 MCBA réglé HM25TC V10 G31	-01-01-15	HM25TC V10 G31
7N	5476G072	786537	1	 MCBA réglé HM25TC V14 G20-25	01-01-15-	HM25TC V14 G20-25
7P	5476G073	786538	1	 MCBA réglé HM25TC V14 G31	01-01-15-	HM25TC V14 G31
8	537D3039	786102	1	 Rectificateur 24V L.1260 45900441-023B		
9	547D3021	786562	1	 Transfo. 230/24V 72VA+ câble 35cm MCBA		
10	537D3020	786091	1	 Circuit clavier pour MCBA		
11	257F1079	785764	1	 Câble plat display vers MCBA		
12	24614167		1	 Tableau cpl HM35TC MK2	-01-02-13	
12	24614192		1	 Tableau cpl HM25-35TC V13	01-02-13-	V13
13	54762049		1	 Connecteur Wago 6P orange mâle		